

23210101

23210 825

ARP AXE MODEL 2300 SERVICE MANUAL

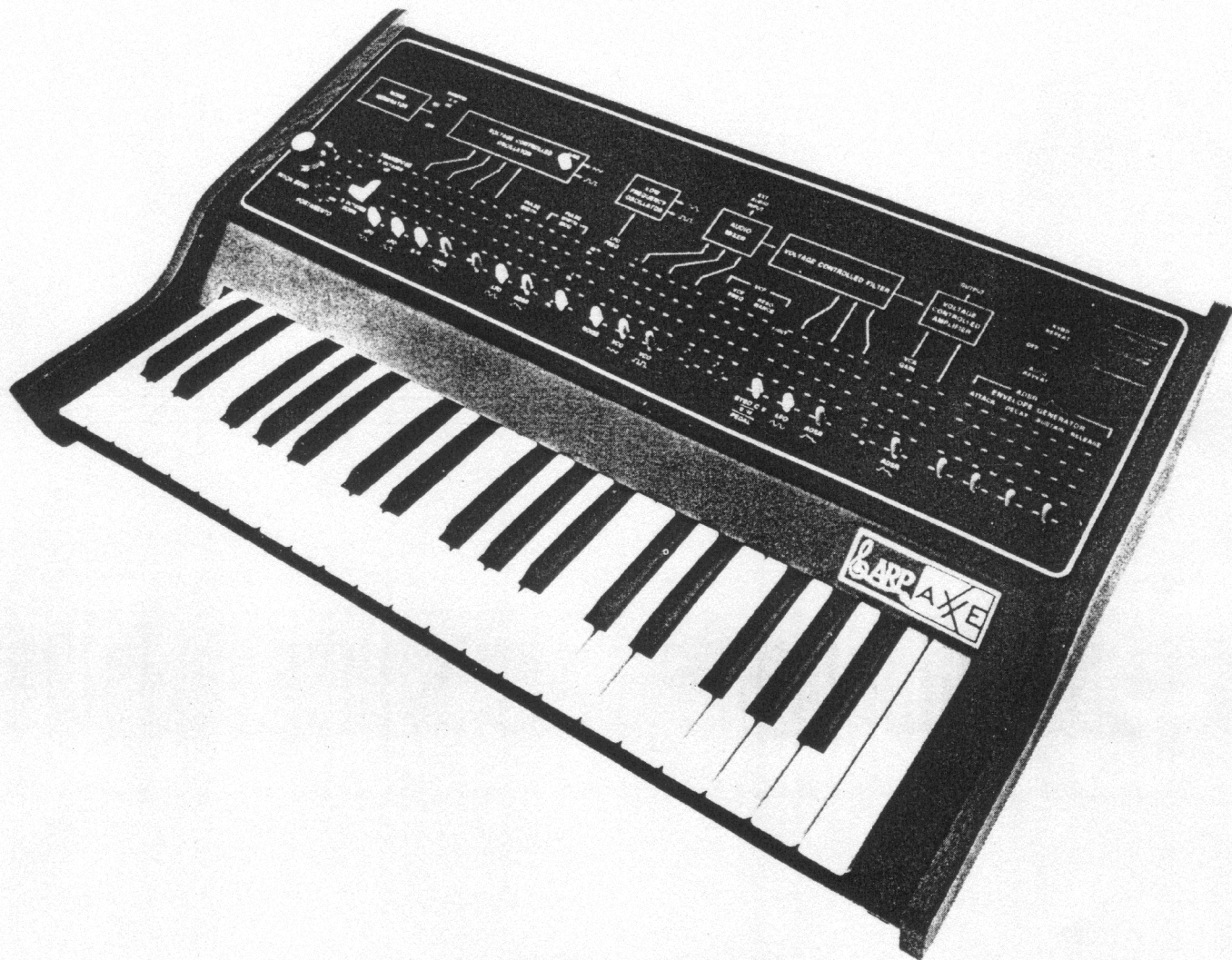

ARP INSTRUMENTS, INC.
45 Hartwell Avenue
Lexington, MA 02173
(617) 861-6000

Document Number 90003
(updated May, 1977)

© May, 1977
ARP INSTRUMENTS, INC.

THE INFORMATION CONTAINED HEREIN IS CONFIDENTIAL AND PROPRIETARY TO ARP INSTRUMENTS, INC. IT IS DISCLOSED TO YOU SOLELY FOR PURPOSES OF INSTRUCTION AS TO OPERATION OF THE EQUIPMENT AND MAINTENANCE AS APPROPRIATE. IT IS NOT TO BE USED BY YOU FOR ANY OTHER PURPOSE, NOR IS IT TO BE DISCLOSED TO OTHERS WITHOUT THE EXPRESS PERMISSION OF ARP INSTRUMENTS, INC.

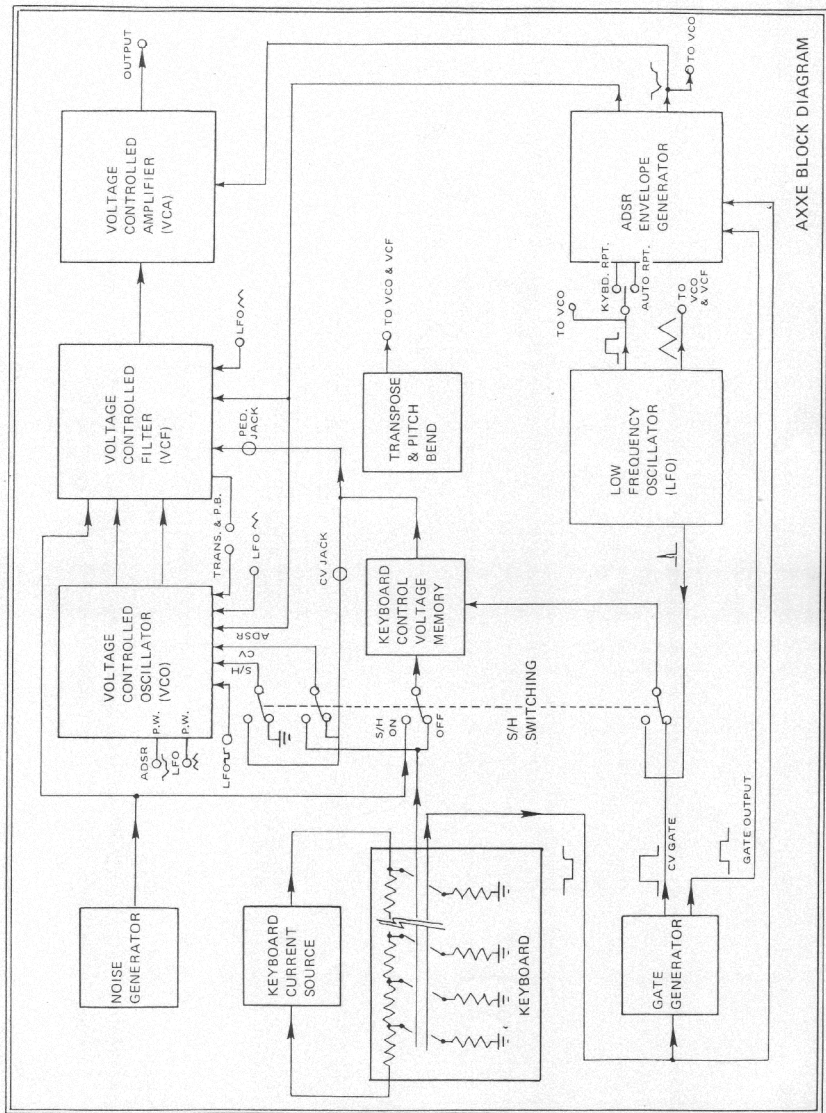

AXXE BLOCK DIAGRAM

2.1 NOISE GENERATOR

The noise generator circuit produces a 25 volt peak to peak pink noise signal which is supplied to the VCF audio input and the KYBD Memory circuit. The noise is obtained by amplifying a reversed biased transistor junction (Q1) in avalanche breakdown. Q1 is a transistor selected for optimum avalanche characteristics and therefore has a good noise producing capability. Q2 is a buffer and Z2 amplifies and clips the noise signal. Z3 filters the noise to provide pink noise to the VCF and memory.

2.2 LFO

The LFO produces a triangle and a square wave output in a frequency range from about .1Hz to 25Hz. Z4A and C11 are an integrator which charges from current passing through R16. Z4B is a hysteretic switch whose output switches from -15 volts to +15 volts when the output of Z4A reaches +5 volts. This then reverses the direction of current through R16 and the rate control (R18) and thus the direction of integration at the output of Z4A. When the output of Z4A reaches -5 volts, the output of Z4B switches back to -15 volts and the cycle repeats. An LFO reset pulse is supplied from the ADSR circuit every time a key is depressed. Q3 is turned on momentarily by the LFO reset pulse and discharges the integrating capacitor (C11) thus resetting the LFO output to zero.

2.3 GATE GENERATOR

Each gate contact on the keyboard is connected to a 2.2K ohm resistor to ground. When a key is depressed, the Gate Generator produces three different gate signals:

SIGNAL:	KEY UP:	KEY DOWN:	TEST POINT:
Gate bus	+15 volts	+10 volts	TP-3
CV Mem. GATE	-15 volts	+15 volts	S1-D, pin 3
Gate Output	-15 volts	0 volts	J1-1

The Gate bus and the Gate output signals are supplied to the ADSR Envelope Generator. The CV Memory Gate signal updates the KYBD CV Memory circuit through S1-D. Q21 converts an external 10 volt gate from other synthesizers to a closure to ground signal which, at the base of Q4, looks like a normal Gate contact closure.

2.4 KYBD CURRENT SOURCE

The Keyboard Current Source supplies a constant current through thirty-six 100 ohm resistors connected in series. This resistor voltage divider string supplies specific voltages for each key on the keyboard. The top end of the resistor string is connected to J1-5 and the low end to J1-6. The current source supplies a three volt drop across the entire resistor chain. This provides a one volt per octave control voltage to the Keyboard Control Voltage Memory circuitry via the KYBD CV bus.

2.5 CV MEMORY

When the Sample and Hold switch (S-1) is in the off (down) position, the Keyboard Control Voltage Memory circuit samples the voltage from the CV bus on a key depression. When the Sample and Hold switch is in the on position (up), S1A connects the output of the noise generator (instead of the voltage from the CV bus) to the input of the Keyboard Control Voltage Memory circuit. The control voltage from the CV bus is then connected directly to the VCO control input via S1B. S1D routes a trigger pulse from the LFO (instead of the keyboard gate) to trigger the memory circuit.

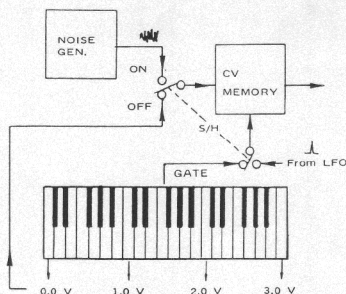

The voltage on S1A pin 2 charges up the memory capacitor (C13) through Q5. Q5 is turned on by the Gate generator or the LFO trigger pulse through CR4. Q6 and Z1A are an FET op amp follower with high input impedance to buffer the voltage on C13. The output of the Keyboard Control Voltage Memory circuit is supplied to the control inputs of the VCO and the VCF via J4-1 and J4-3.

2.6 ADSR

The ADSR envelope generator circuit provides a negative going DC voltage to control the VCF cutoff and the VCA.

ATTACK: When a key is depressed, the gate voltage (TP3) rises from -15 volts to 0 volts and the pulse drive on J1-1 drops to ± 10 volts. Q7, C15, and Z5A prevent Z5B from changing state for about 10 milliseconds. The delay pulse on Z5A pin 3 is used for the LFO reset pulse through C10. When the output of Z5B changes from high to low, -15 volts is applied through CR10 and R46 to the noninverting input of follower Z6. During the attack mode, Q10 is off, and R45 is disconnected from ground. Z6 directly follows the voltage on pin 3 and applies -15 volts through CR12, R50 to charge integrating capacitor C18 down.

DECAY AND SUSTAIN: Z7 is a buffer amplifier following the voltage on capacitor C18. The output of ADSR voltage approaches -13 volts, Q8 begins to turn off and R39 lowers the voltage on pin 13 of Z5D, Z5C and Z5D is a bistable latch. When pin 13 falls below the threshold of the NAND gate (about -7.5 volts) the output of Z56 changes from high to low applying -15 volts from pin 10 of Z5 through CR9, R42, and CR8 thus holding Q8 off. Q10 now turns on and the voltage divider consisting of R45 and R46 establishes the Sustain Level. CR12 is now reversed biased and capacitor C18 discharges through R49 and CR11 to the level at Z6 pin 3.

RELEASE: When the gate voltage is removed, Q9 turns on which turns on Q11. The remaining voltage on capacitor C18 discharges through R55, R54 and Q11 to ground. The output of Z7 is applied to the input of follower Z6 through R53 thereby preventing the sustain and decay charge paths from affecting the release time. Z8E, Z8D and Z8C invert the output of the ADSR to control the VCO and VCF.

2.7 VCA

The VCA attenuates signals from the output of the VCF. The gain of the VCA is determined by the amount of current supplied to the differential pair Z8C,B. The ADSR output is connected to the control input (pin 3, Z8B) via the VCA 'ADSR' slider R170. R173 manually controls the VCA gain. The control rejection trimmer (R180) minimizes the effect of control voltage changes on the output of the VCA by balancing the current through Z8A and Z8B. CR19, CR20 and R179 provide output protection to prevent external voltages from entering the AXE circuits through the output jack.

This chart shows test points in the ADSR. Refer to the board schematic for the locations of these test points.

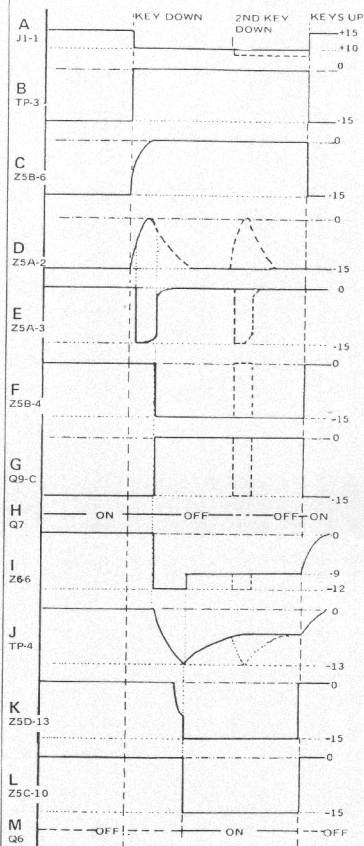

USE X10 PROBE WITH OSCILLOSCOPE

2.8 VCO

Control voltages from the keyboard, Initial Frequency and Fine Tune sliders, the Sample and Hold circuit, LFO square wave and sine wave, and the ADSR are summed on the base of Q12. Q12 and Q13 are a linear voltage to exponential current converter; for every volt applied to one of the control inputs of the VCO, Q13 will conduct twice as much current. C22 is the integrating capacitor; it is initially charged to fifteen volts and discharges through R96 and Q13 toward ground. Q13 determines the discharge time of the capacitor and therefore the oscillator frequency. Q15 buffers the voltage on C22 and supplies it to a comparator, Z9B and Z9A. Pin 2 of Z9A is fixed at about 7.5 volts. When the voltage on pin 4 of Z9B decreases to below 7.5 volts, Z9A turns on Q16 which supplies +15 volts to the gate of Q14. Q14 then charges capacitor C22 back to +15 volts to start the cycle over again.

R91, C21 and R92 supply current to Q13 as the frequency of the oscillator is increased to prevent the oscillator from going flat, due to the recovery time of the circuit. Q17 is an emitter follower which takes the sawtooth from pin 3 of Z9 and supplies it to the oscillator output. The sawtooth waveform on the emitter of Q17 is 7.5 volts peak to peak, and +7.5 volts offset.

2.9 VCF

Audio signals from the VCO, noise generator, and the external audio input are summed on the base of Z12E. Z12E and Z12B are a differential amplifier. Four

series RC circuits comprised of capacitors C26, 27, 28 and 29 and the emitter-base junction resistances of Z10C-D, Z10B-E, Z11C-D, and Z11B-E provide four pole low-pass filtering. Varying the amount of current through the pairs of transistors changes the resistive value of the emitter-base junction, thereby changing the cutoff frequency of the filter. Control voltages from the filter frequency sliders, calibrate trimmer, CV pedal, keyboard CV, ADSR, LFO triangle are summed on the base of Q20. Q20 and Q19 are an exponential current converter; for each volt applied to the control input (Q20 base) the current through Q19 will double. Q19 controls the current through the filter ladder thus controlling the filter cutoff. R145, the control rejection trimmer, balances the current through both halves of the filter ladder which minimizes the effect of control voltages on the filter output.





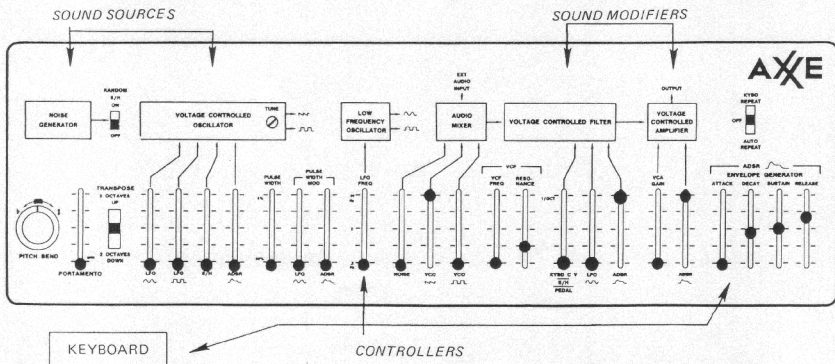

Q18 and Z13A are a high impedance differential amplifier which brings signals from the filter ladder up to about one volt peak to peak. R144, the resonance slider, provides a manually adjustable amount of feedback from the output of the filter to the inverting input of the filter (Z12B, Base). When enough of the output signal is supplied via the resonance slider to the inverting input, the VCF will begin to oscillate, producing a sine wave.

NOTE: This filter is used in older models only. See the Service Revision section of this manual for the current type.

BASIC AXXE 'PATCH'



BOARD TRIMS AND ADJUSTMENTS SECTION 3

REF. NO.	TRIMMER	TRIM PROCEDURE
R76 	VCO CALIBRATE	<ol style="list-style-type: none"> 1. Monitor TP-6 with a frequency counter. 2. Pin low 'C' on the keyboard. 3. Put the Transpose and Pitch Bend controls in the 'normal' (mid) position. 4. Set the 'Tune' control on the front panel in the mid position. 5. Adjust trimmer R76 for a 130 Hz. sawtooth wave (± 2 Hz.).
R74 	VCO V/OCT	<ol style="list-style-type: none"> 1. Monitor TP-6 with a frequency counter or strobe tuner. 2. Pin low 'C' on the keyboard. 3. Put the Transpose and Pitch Bend controls in the 'normal' (mid) position. 4. Put the S/H slide switch in the down position and put all sliders in the minimum position. 5. Adjust the 'Tune' control on the front panel to exactly 130Hz * or 'C' on a strobe tuner. 6. Pin high 'C' on the keyboard. 7. Adjust trimmer R74 for exactly 1040Hz. or 'C' three octaves higher than step 5 on the strobe tuner. 8. Repeat steps 1 through 7 until the frequency is correct on low 'C' and high 'C'. <p align="right">* IF MORE ACCURACY IS DESIRED, TUNE TO 130.8127826Hz</p>
R62 	TRANPOSE CAL	<ol style="list-style-type: none"> 1. Monitor TP-6 with a frequency counter or strobe tuner. 2. Pin low 'C' on the keyboard. 3. Put the Transpose and Pitch Bend controls in the 'normal' (mid) position. 4. Adjust the 'Tune' control on the front panel to exactly 130Hz. 5. Put the Transpose control in the 'Up Two Octaves' position. 6. Adjust trimmer R62 for exactly 520Hz. or 'C' two octaves higher than step 4.
R70 	PITCH BEND CAL	<ol style="list-style-type: none"> 1. Monitor TP-6 with a frequency counter or strobe tuner. 2. Pin low 'C' on the keyboard. 3. Put the Transpose and Pitch Bend controls in the 'normal' (mid) position. 4. Adjust the 'Tune' control on the front panel to exactly 130Hz. 5. Put the Pitch Bend control fully clockwise. 6. Adjust trimmer R70 for exactly 260Hz. or 'C' one octave higher than step 4.
R114 	VCO PULSE WIDTH	<ol style="list-style-type: none"> 1. Monitor TP-7 with an oscilloscope. 2. Put all sliders in fully down position. 3. Adjust the time base of the oscilloscope so that exactly one complete cycle is displayed. 4. Adjust trimmer R114 for exactly 50% pulse width (square).
R180 	VCA CONTROL REJECT	<ol style="list-style-type: none"> 1. Monitor the Audio Output of the Axxe with an oscilloscope. 2. Put the LFO Frequency slider fully up. 3. Put the VCA ADSR slider fully up. 4. Put the KYBD Repeat switch in the Auto Repeat (down) position. 5. Put all other sliders fully down. 6. Adjust R180 for minimum signal amplitude.

REF. NO.	TRIMMER	TRIM PROCEDURE
R158 ⊗	FREQ. CAL	<ol style="list-style-type: none"> 1. Monitor TP-8 with an oscilloscope. Set the amplifier to .5V/div. and the time base to 10 msec./div. 2. Raise the VCF Resonance slider to maximum and put all other sliders fully down. 3. Adjust trimmer R158 for 62.5msec. sinewave.
R196 ⊗	CVF CVR REJ	<ol style="list-style-type: none"> 1. Monitor TP-8 with an oscilloscope. 2. Put Filter and Resonance slider fully down. 3. Put LFO slider $\frac{3}{4}$ up. 4. Put ADSR filter control slider up full and turn on Auto Repeat. (All other sliders down.) 5. Adjust R196 for minimum amplitude.
R165 ⊗	VCF V/OCT	<ol style="list-style-type: none"> 1. Monitor TP-8 with a frequency counter or strobe tuner. 2. Put the VCF Resonance slider fully up. 3. Pin low 'C' on the keyboard. 4. Raise the VCF keyboard CV slider. 5. Put the S/H switch in the down position. 6. Adjust the VCF Frequency slider on the front panel to exactly 130Hz. or 'C' on the strobe tuner. 7. Pin high 'C' on the keyboard. 8. Adjust trimmer R165 for a frequency of 1040Hz. or 'C' three octaves higher than step 6. 9. Repeat steps 1 through 8 until the frequency is correct on high 'C' and low 'C'.

POWER SUPPLY TRIMS

CAUTION: DO NOT ADJUST POWER SUPPLY UNLESS A COMPONENT FAILURE OCCURS. SEE SECTION 5.1 SHOULD ADJUSTMENT BECOME NECESSARY.

REF. NO.	TRIMMER	TRIM PROCEDURE
R5 ⊗	+15 VOLT SET	<ol style="list-style-type: none"> 1. Monitor the power supply's +15 volt output with a digital voltmeter. 2. Adjust R5 for exactly +15.00 volts.
R11 ⊗	15 VOLT SET	<ol style="list-style-type: none"> 1. Set R5 (+15 volts) first. 2. Put the digital voltmeter's ground lead on the power supply's -15 volt output and put the meter's plus lead on the power supply's ground output. 3. Adjust R11 for exactly +15.00 volts.

SECTION 4 BOARD TEST POINTS

TEST POINT	FUNCTION	SET UP	SPECIFICATIONS
TP-1	NOISE GENERATOR OUTPUT	-----	
TP-2	LFO SQUARE WAVE	1. Put LFO Frequency slider fully up.	

TEST POINT	FUNCTION	SET UP	SPECIFICATIONS
TP-3	GATE OUTPUT	1. Depress any key.	
TP-4	ADSR OUTPUT (NEGATIVE)	1. Put Attack, Decay, Sustain and Release sliders $\frac{1}{4}$ up.	
TP-5	ADSR OUTPUT (POSITIVE)	1. Put Attack, Decay, Sustain and Release sliders $\frac{1}{4}$ up.	
TP-6	VCO SAWTOOTH OUTPUT	<ol style="list-style-type: none"> 1. Pin low 'C' on the keyboard. 2. Put the S/H switch in the down (off) position. 3. Put all other sliders fully down. 4. Put the Transpose switch and Pitch Bend control in the normal (mid) position. 	
TP-7	VCO SQUARE-WAVE OUTPUT	<ol style="list-style-type: none"> 1. Pin low 'C' on the keyboard. 2. Put the S/H switch in the down (off) position. 3. Put all other sliders fully down. 4. Put the Transpose switch and Pitch Bend control in the normal (mid) position. 	
		5. Raise the VCO Pulse Width slider fully.	
TP-8	VCF OUTPUT	<ol style="list-style-type: none"> 1. Put Audio Mixer VCO Sawtooth slider fully up. 2. Put VCF Frequency slider fully up. 3. Put all other sliders down fully. 	
		<ol style="list-style-type: none"> 4. Lower the VCF Frequency slider to $\frac{1}{4}$ up. 5. Raise the VCF Resonance to $\frac{1}{2}$. 	

SECTION 5 INTERFACING INFORMATION

5.1 MASTER/SLAVE TUNING INSTRUCTIONS

Select one Axxe as the master unit and put it to the left of the slave unit. Instructions in the left column refer to the 'master unit'; the left column refers to the 'slave'. Be sure to follow the sequence of operations for both units.

INSTRUCTIONS FOR 'MASTER' UNIT:	INSTRUCTIONS FOR 'SLAVE' UNIT:
1. Connect High or Low output to amplifier.	2. Connect High output to EXT AUD input of master unit.
3. Connect a patch cord to the CV output jack and the CV input of the slave unit.	5. Raise the VCO Square Wave slider.
4. Pin low 'C' on the keyboard.	6. Put the VCF FREQ slider up fully.
5. Raise the VCO Square Wave slider.	7. Raise the VCA GAIN fully.
6. Put the VCF FREQ slider up fully.	8. Put the TRANPOSE and PITCH BEND controls in the normal (mid) position.
7. Raise the VCA GAIN to a comfortable level.	9. Put the S/H switch and all other sliders in the off or normal position.
8. Put the TRANPOSE and PITCH BEND controls in the normal (mid) position.	12. Using VCO V/OCT trimmer (R74), tune the slave unit to unison with the master unit.
9. Put the S/H switch and all other sliders in the off or normal position.	14. Remove patch cord from CV input.
10. Using the 'TUNE' control on the front panel, tune the master unit to unison with the slave unit.	15. Pin high 'C' on the keyboard.
11. Pin high 'C' on the keyboard.	16. Adjust the 'TUNE' control on the front panel so that slave and master are tuned to unison.
13. Pin low 'C' and check that the two units are still tuned to unison (repeat steps 10 through 12 if not in tune).	17. Pin low 'C' on the keyboard.
14. Remove patch cord from CV output.	18. Adjust trimmer R5 (+15 V, power supply) until the master and slave are tuned to unison.
15. Pin high 'C' on the keyboard.	
17. Pin low 'C' on the keyboard.	
19. Repeat steps 15 through 18 until master and slave units are in tune on low 'C' and high 'C'.	
20. Check section 3 (Board Trims) to verify calibration of pitch bend and transpose switch.	

5.2 SYSTEMS INTERFACING WITH OTHER ARP SYNTHESIZERS

Axxe	SE-4	2600	2800	2950
Gate Output	—	Gate Jack	Gate Input	Gate Input
Trigger Output	—	Trigger Jack	Trigger Input	Trigger Input
CV Output	—	CV Output (disconnect KYBD)	CV Input (newer models only)	CV Input
EXT AUD Input	Output I	L or R Output	High Output	High Output

WHEN THE AXXE IS TO BE USED AS A SLAVE (CONTROLLED) UNIT, CONNECT: TO:

Axxe	SE-4	2600	2800	2950
Gate Input	Gate Output	Gate Jack	Gate Output	—
Trigger Input	Trigger Output	Trigger Jack	Trigger Output	—
CV Input	—	CV Output	CV output	—

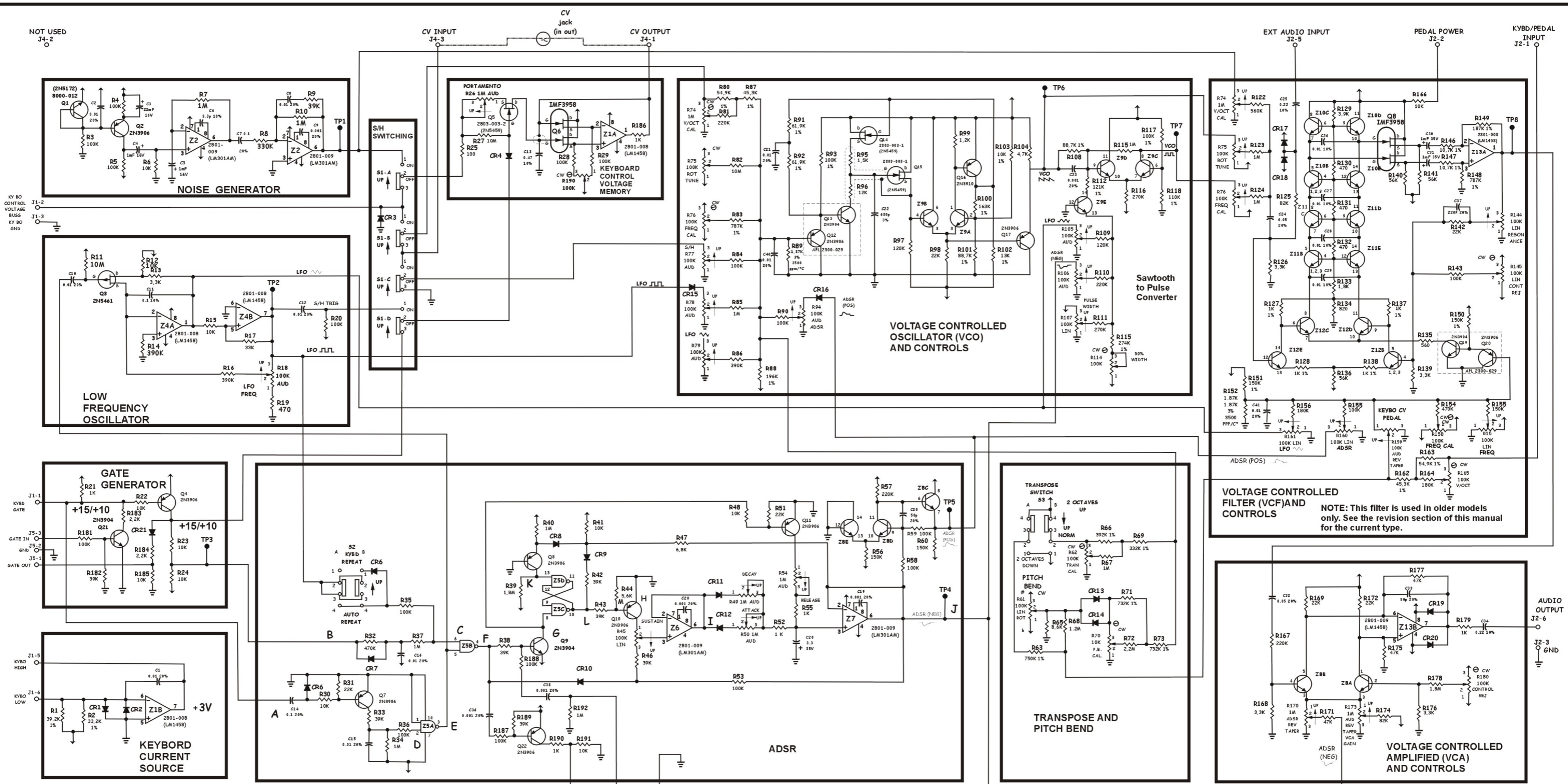

VOLTAGE CONTROLLED FILTER (VCF) AND CONTROLS

NOTE: This filter is used in older models only. See the revision section of this manual for the current type.

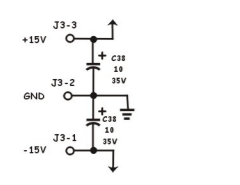

00/00=Key up voltage/Key down voltage

+15

J6-1 TRIGGER OUTPUT

J6-2 TRIGGER INPUT

J6-3 GND

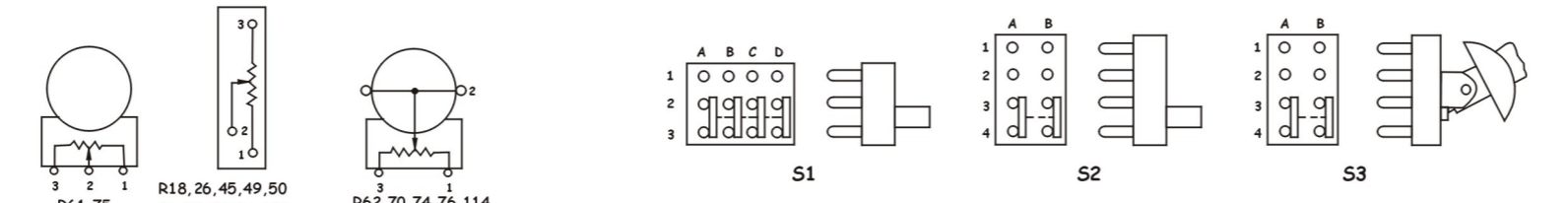

MK1

Model: Arp Axxe MK1

Remastering: Marco Molendi

Not for Resale !!

Freely shareable document

BASE VIEW (LOOKING TOWARD TERMINAL)

R18,26,45,49,50
54,77-79,94,150-
107,119-121,144,157,
159-161,170,173

R61,75

R62,70,74,76,114,
145,158,165,180

- NOTES:
- UNLESS OTHERWISE SPECIFIED:
ALL RESISTOR VALUES ARE IN OHMS
ALL CAPACITOR VALUES ARE IN mF (P. PICO FARADS)
 - HIGHEST REF DES: C42, CR21, J6, Q22, R192, S3, 4 Z13
 - CONVENTION USED FOR SUPPLY VOLTAGE CONNECTIONS:
↑ IMPLIES +15 ↑
↓ IMPLIES -15 ↓
- Z5 13 2803-002 (SEL CD-4011AB)
Z8 Z9 ARE CA3086
Z4 I5 4034-006-4 (SEL CA3086)
Z4 I1 I5 4034-006-3 (SEL CA3086)
Z4 I2 I5 4034-006-2 (SEL CA3086)



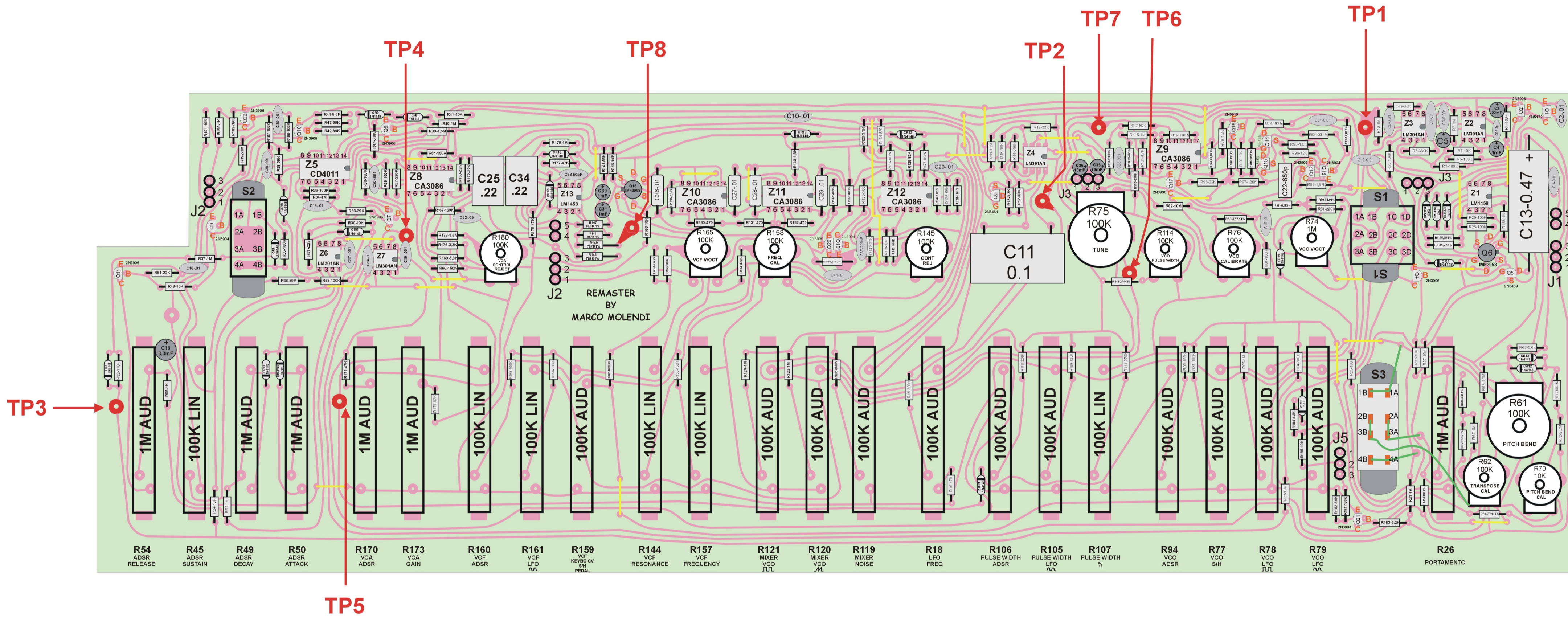

<h1>MK1</h1>		Not for Resale !! Freely shareable document
Model: Arp Axse MK1		
Remastering : Marco Molendi		

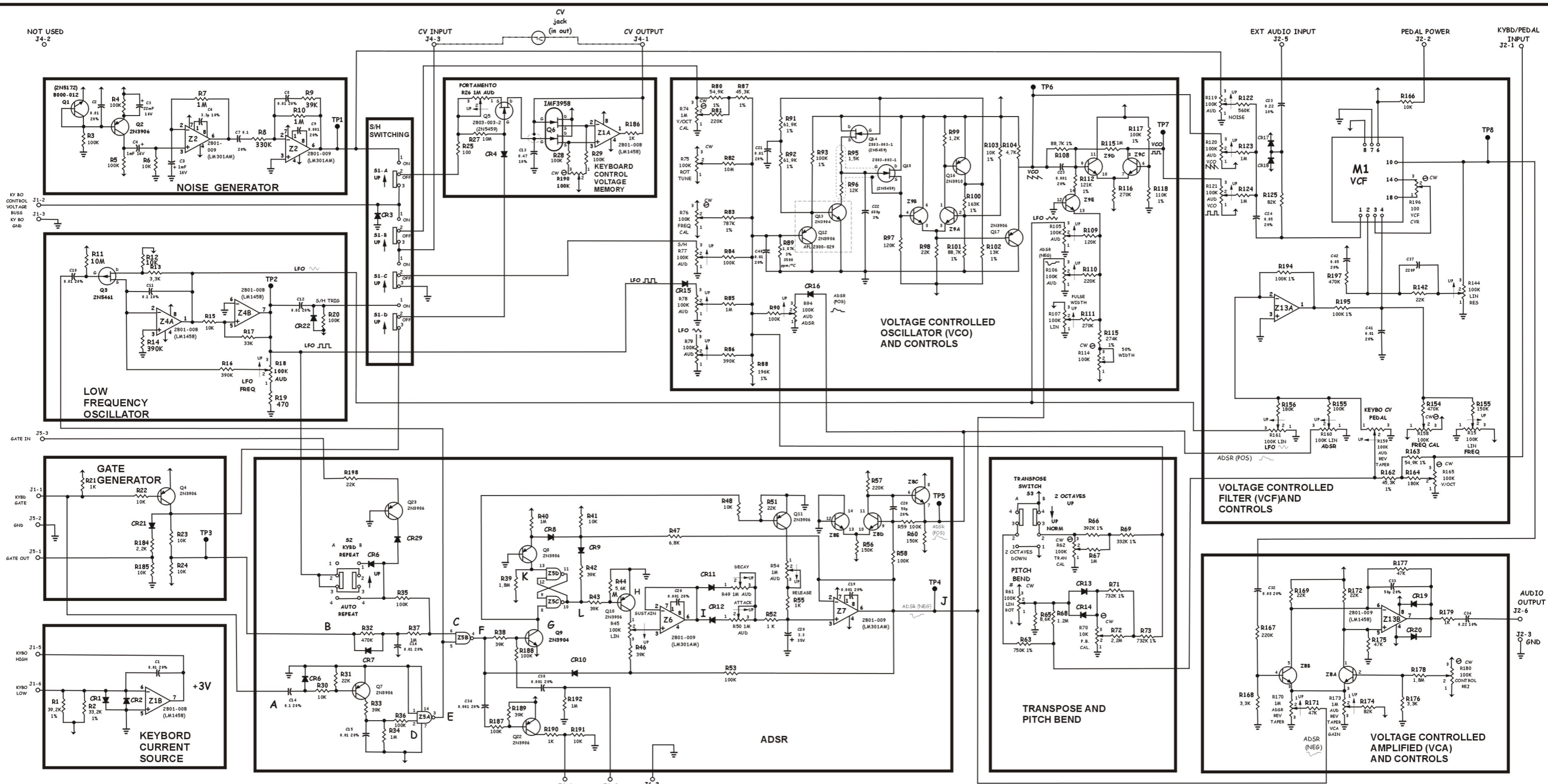

MK2
 Model: Arp Axxe MK2
 Remastering: Marco Molendi

Not for Resale !!
 Freely shareable document

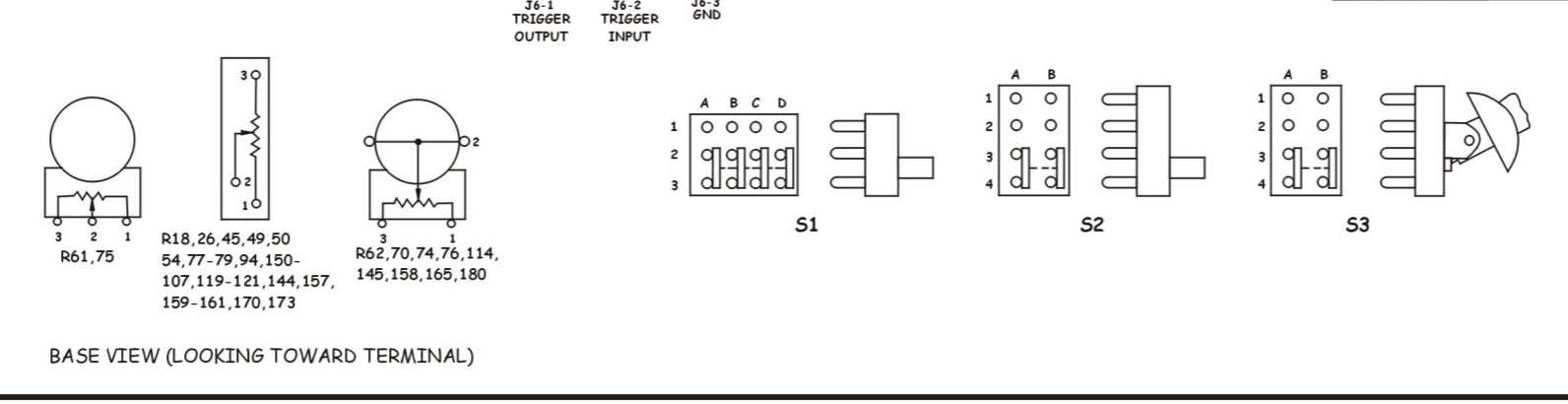

- NOTES:**
- UNLESS OTHERWISE SPECIFIED:
 ALL RESISTOR VALUES ARE IN OHMS
 ALL CAPACITOR VALUE ARE IN mF (P. PICO FARADS)
 ALL DIODES ARE 1N4148
 - HIGHEST REF DES:
 C42, CR21, J6, Q22, R192, S3, Z13
 - CONVENTION USED FOR SUPPLY VOLTAGE CONNECTIONS:
 ↑ IMPLIES +15 ↑
 ↓ IMPLIES -15 ↓
 - Z5 13 2803-002 (SEL CD4011AB)
 Z8 Z9 ARE CA3086
 Z410 IS 4034-006-4 (SEL CA3086)
 Z411 IS 4034-006-3 (SEL CA3086)
 Z412 IS 4034-006-2 (SEL CA3086)

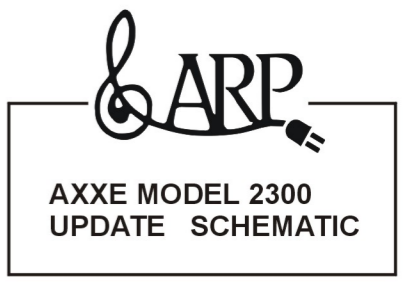

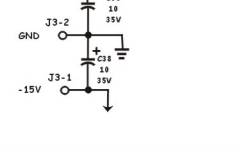
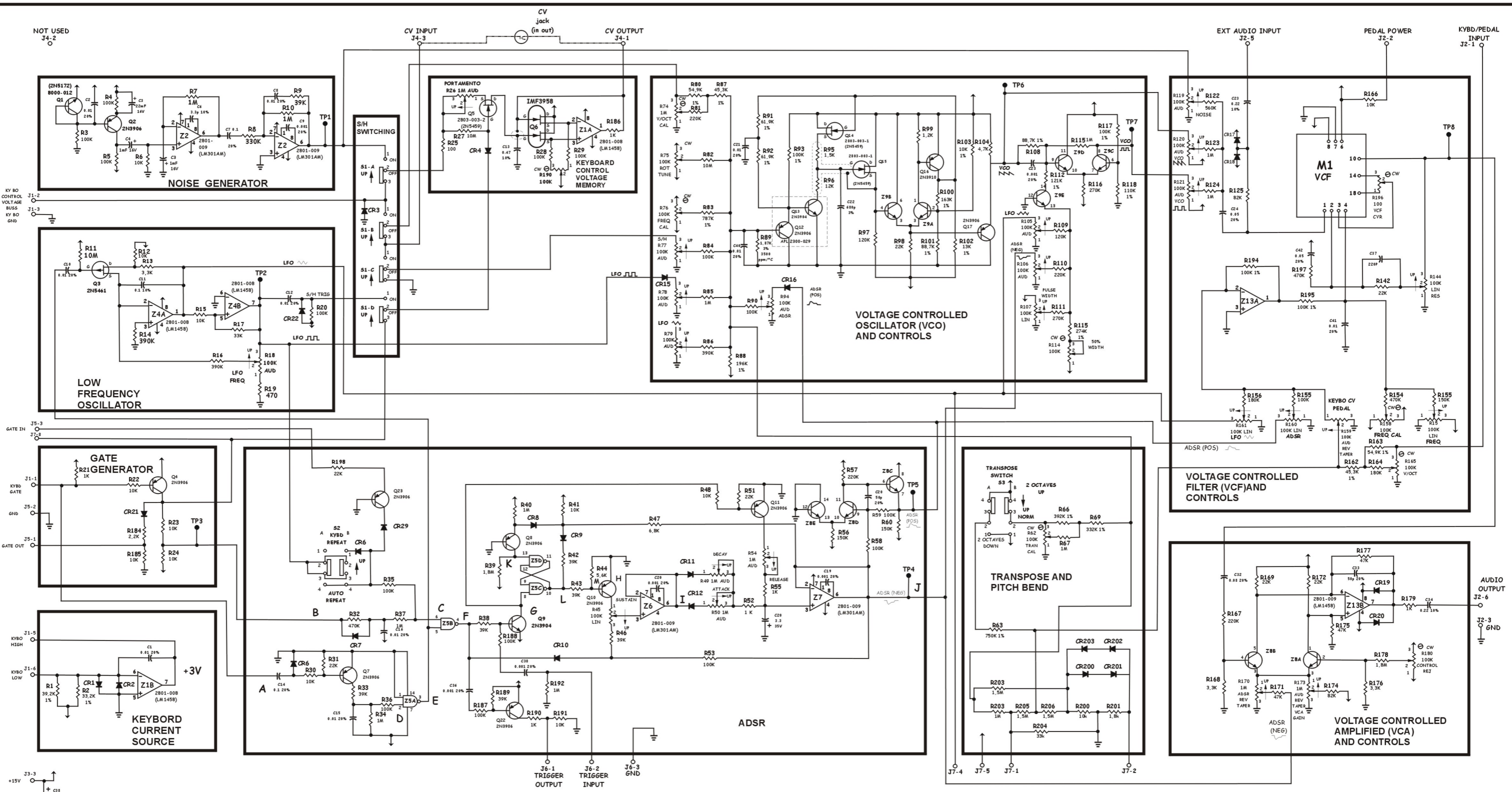

MK3
 Model: Arp Axxe MK3
 Remastering: Marco Molendi

Not for Resale !!
 Freely shareable document

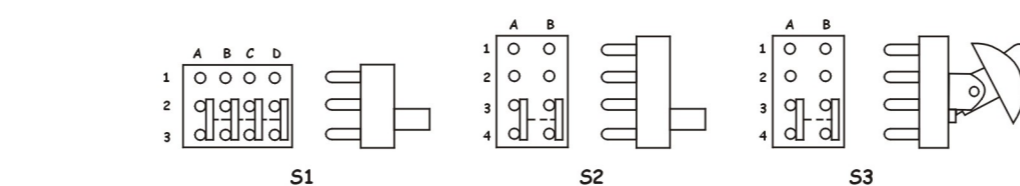
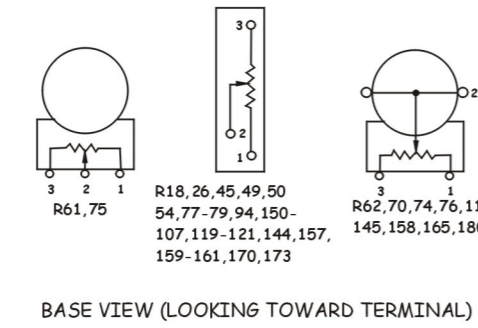

- NOTES:**
- UNLESS OTHERWISE SPECIFIED:
 ALL RESISTOR VALUES ARE IN OHMS
 ALL CAPACITOR VALUES ARE IN mF (P. PICO FARADS)
 - HIGHEST REF DES:
 C42, CR21, J6, Q22, R192, S3, 4 Z13
 - CONVENTION USED FOR SUPPLY:
 VOLTAGE CONNECTIONS:
 ↑ IMPLIES +15 V
 ↓ IMPLIES -15 V
 - Z5 13 2803-002 (SEL CD-40114B)
 Z8 Z9 ARE CA3086
 Z410 IS 4034-006-4 (SEL CA3086)
 Z411 IS 4034-006-3 (SEL CA3086)
 Z412 IS 4034-006-2 (SEL CA3086)

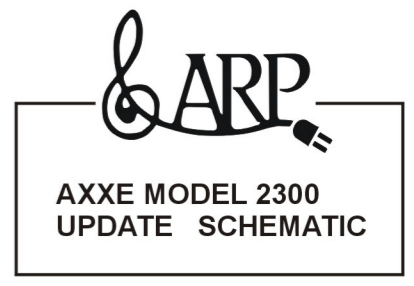

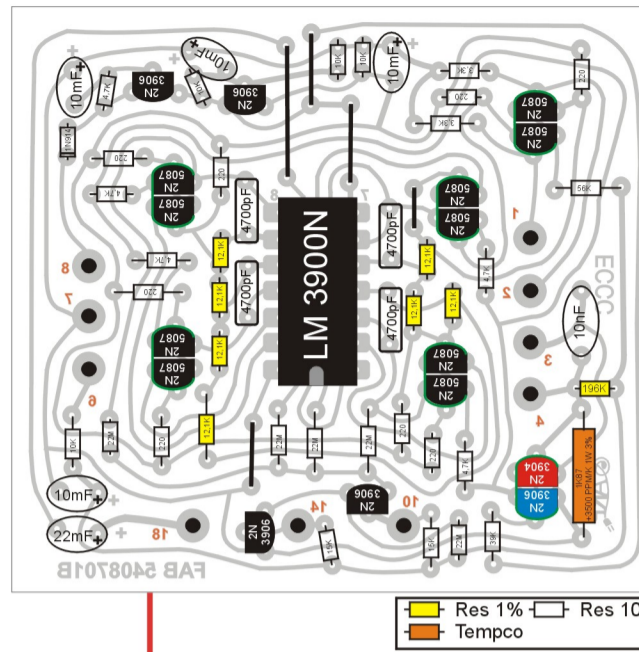

**M1
7210501
(4075)**

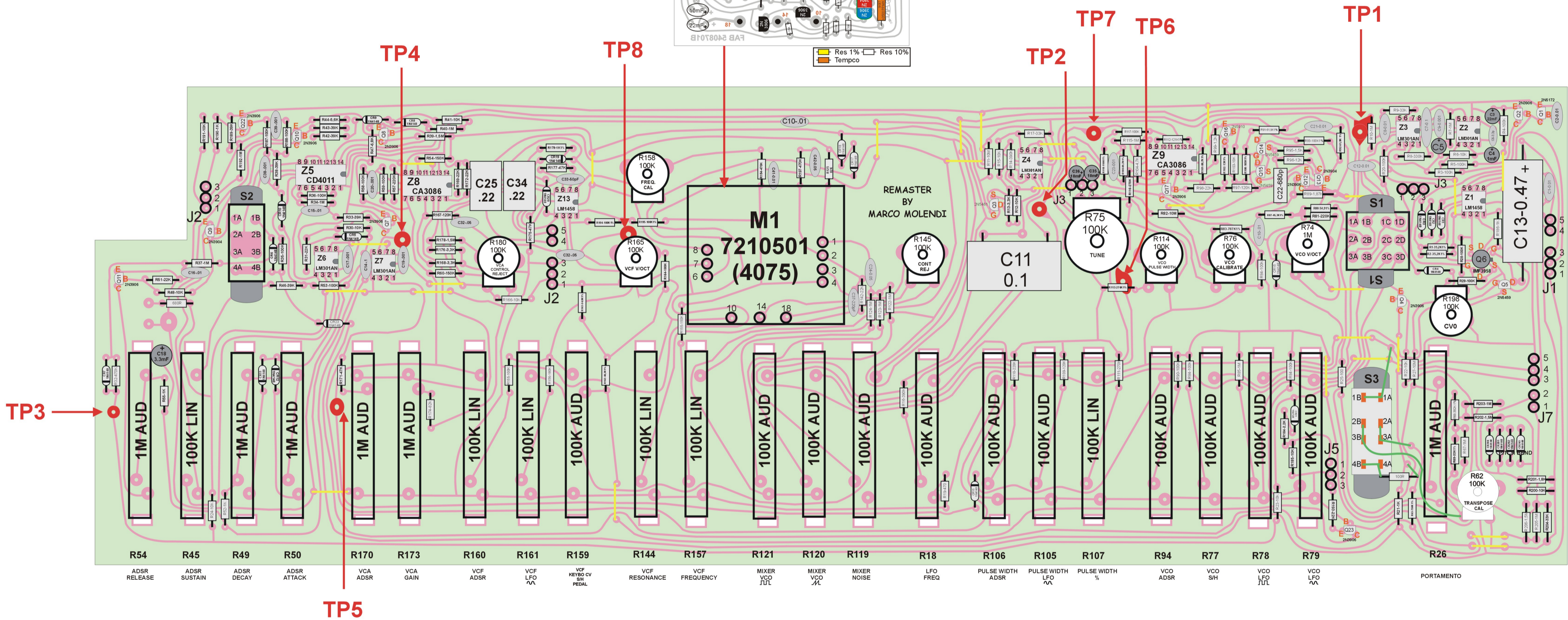

REMASTER
BY
MARCO MOLENDI

<h1>MK3</h1>		Not for Resale !! Freely shareable document
Model: Arp Axse MK3		
Remastering : Marco Molendi		

7.1 POWER SUPPLY CIRCUIT DESCRIPTIONS

7.1.1 VOLTAGE SOURCE

CRI-4 is a full wave bridge rectifier supplying about plus and minus 28.5 volts to the regulating circuitry. C1 and C5 filter out ripple on the supply lines.

7.1.2 +15 VOLT SUPPLY

Z1 contains a voltage reference which supplies about 7.4 volts to pin 6 of Z1. This fixed voltage is connected through pin 5 to the non-inverting input of an op amp. The output of the op amp is connected to an emitter follower, also located inside Z1, which controls the current amplifier. The power supply normally delivers +15 volts to the output; if the voltage should change, the voltage at the junction of R3 and R6 will also change. This point is connected to the inverting input of the op amp through pin 4 of Z1. If the voltage at this point should drop, the output of the op amp will rise, turning on the emitter follower and the current amplifier, thus increasing the output voltage. Similarly, if the voltage at the resistor junction should increase, the voltage on the output of the op amp will decrease which limits the current through the current amplifier and lowers the output voltage. R5 and the +15 volt trimmer sets the voltage level on the inverting input of the op amp and thus sets the output voltage of the supply.

7.1.3 +15 VOLT CURRENT LIMITING

When enough current flows out of the positive power supply to cause a .7 volt drop across R2, the transistor connected to pins 2 and 3 of Z1 turns on, effectively shorting the base of the emitter follower to the output voltage of the +15 supply. Q1 in turn supplies less current to the output.

7.1.4 -15 VOLT SUPPLY

The -15 volt supply derives its regulation from the +15 volt supply through R8. When the output of the -15 volt supply is at the correct voltage, the junction of R8 and R12 is zero volts. The base of Q2 is referenced to zero volts through R9. Should the output of the supply increase, the voltage on the base of Q3 will also increase which begins to turn off Q3. Q2 conducts more current thus turning Q4 on harder. Q4 drives the current amplifier Q5 which will then conduct more current thereby lowering the output to -15 volts.

7.1.5 -15 VOLT CURRENT LIMITING

When enough current is drawn from the -15 volt supply to cause a .7 volt drop across R16, Q6 turns on which applies -28 volts to the base of Q4 thus shutting Q4 and Q5 off.

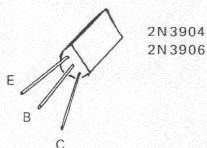

NAND GATE
(CD4011AE)

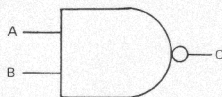

A	B	C
0	0	1
0	1	1
1	0	1
1	1	0

1 = >7.5V
0 = <7.5V

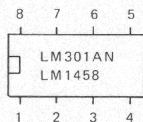

TOP VIEW

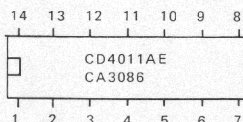

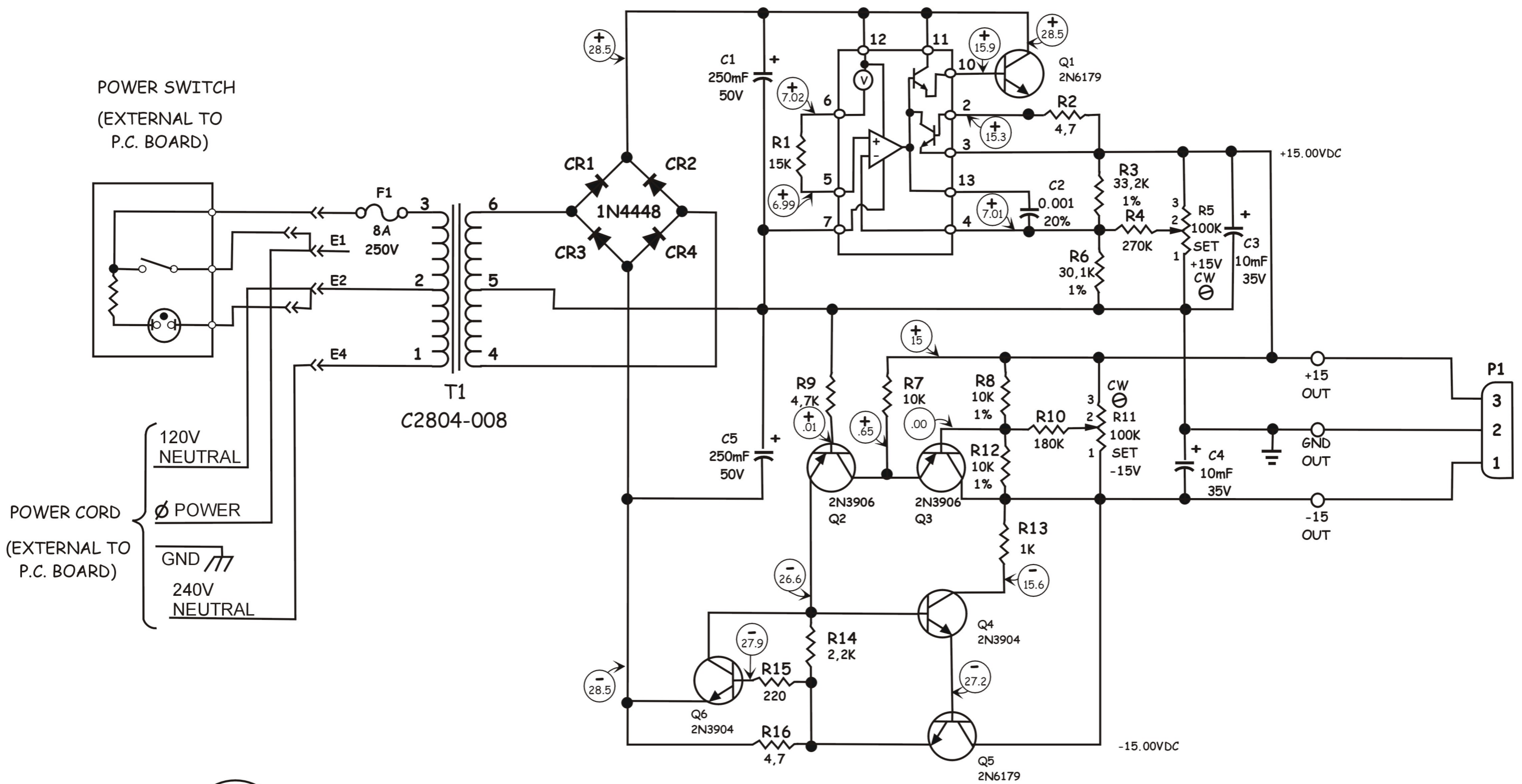

POWER SWITCH
(EXTERNAL TO
P.C. BOARD)

POWER CORD
(EXTERNAL TO
P.C. BOARD)

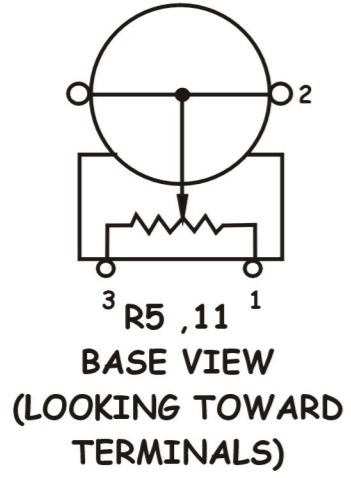

- NOTES:
- 1: UNLESS OTHERWISE SPECIFIED :
RESISTOR VALUES ARE IN OHMS
 - 2: HIGHEST REF.DES : Q6,Z1,CR4,C5,R16, ,E4,T1, F1
 - 3: (+/0.0) INDICATES TYPICAL VOLTAGE AS READ WITH A DVM.

<h1>Power Supply</h1>	
Model: Arp Axxe	Not for Resale !! Freely shareable document
Remastering : Marco Molendi	

BOARD SCHEMATICS
POWER SUPPLY

MOUNTING ALTERNATE
TRANSISTOR D4004

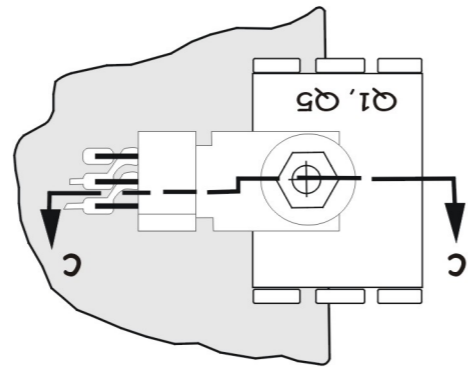

MOUNTING ALTERNATE
TRANSISTOR 2N5298 & 2N5494

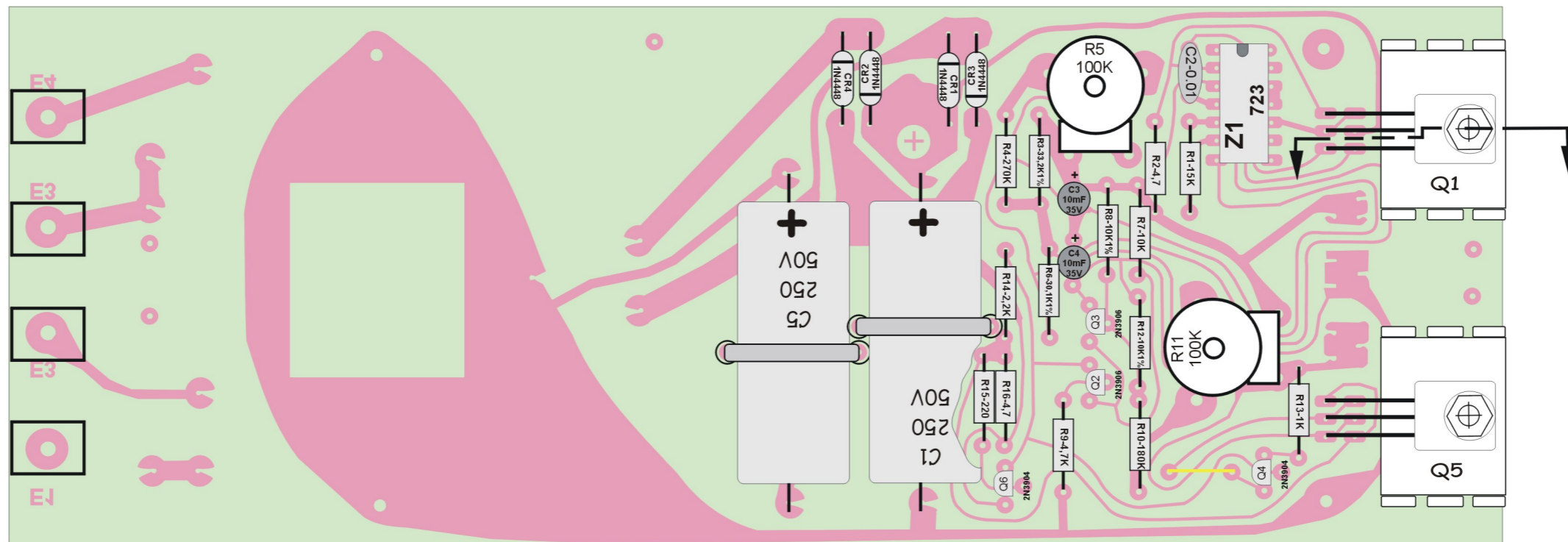
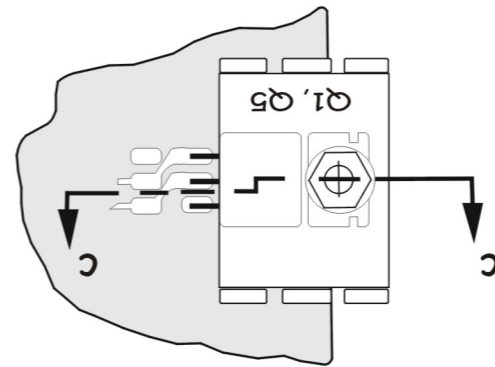

BOARD LAYOUT
COMPONENT SIDE VIEW

Power Supply		Not for Resale !! Freely shareable document
Model: Arp Axxe		
Remastering : Marco Molendi		

SECTION 8 AXXE PARTS LIST

2300 PARTS LIST

ORDER PARTS BY ARP PART NUMBER

REFERENCE	ARP PART NUMBER	ARP/MFG NUMBER	DESCRIPTION
CR1-23	1200301	IN4148	Diode, Silicon, Signal
Q9	1302901	2N3904	Transistor, Silicon, NPN
Q2,4,7,8,10,11,17,22,23	1303001	2N3906	Transistor, Silicon, PNP
Q12,13	7500801	2300-029	Transistor Pair NPN/PNP
Q1	5600101	A8000-012	Transistor, Noise, Sel. 2N5172
Q16	1302701	2N5910	Transistor, Silicon, PNP
Q14,15	5600201	A2803-003-1	FET, Selected, 2N5459(ORN)
Q5	5600202	A2803-003-2	FET, Selected, 2N5459(YEL)
Q3	1302501	2N5461	FET, P Channel
Q6	1303901	IMF3958	FET, DUAL JFET
Z1,4,13	1401101	A2801-008/SL19988	DUAL OP AMP(LM1458)Sel.
Z2,3,6,7	1400801	A2801-009/SL19986	OP AMP(LM301AN) Sel.
Z8,9	1400501	CA3086	Transistor Array
Z5	1400601	A2803-002	Quad/2 input NAND GATE(CD4011AE)
R89	1000105	SA-21	THERMISTOR, 1.87K 3%
R61	5701802	B2801-010-2	Rotary Pot., 100K Lin.
R75	5701803	B2801-010-3	Rotary Pot., 100K Lin.
R45,107,144,157,160,161	5700703	B2801-006-3	Slide Pot., 100K Lin.
R18,77,78,79,94,105,106, 119,120,121,159	5700702	B2801-006-2	Slide Pot., 100K Aud.
R26,49,50,54,170,173	5700701	B2801-006-1	Slide Pot., 1M Aud.
S2	1900601	SW423AKKB	Switch, Slide, DP3T
S1	1900701	SW442AKKB	Switch, Rocker, DP3T
S3	1900801	02-481-0001	Switch, Rocker, DPDT

2300 POWER SUPPLY PARTS LIST

REFERENCE	ARP PART NUMBER	ARP/MFG NUMBER	DESCRIPTION
Q1,5	1303401/1303601	2N6179/or D40D4	NPN Power Transistor
Q4,6	1302901	2N3904	Silicon Transistor, NPN
Q2,3	1303001	2N3906	Silicon Transistor, PNP
Z1	1401301	723	+15 Regulator I.C.
CR1-4	1200401	IN4448	Rectifier Diode, 75V, 200MA.
C3,4	1100612	TAG-00-10/35-50/20	10uF, Tant. 35V Capacitor
C1,C5	1101702	B41010-250/50	250uF, Elect. 50V Capacitor
T1	5701201	C2804-008	Power Transformer
---	1700402	MDV-1/8	Slo-Blow Fuse, 1/8 AMP



AXXE MODEL 2300 SERVICE MANUAL

TABLE OF CONTENTS

1. INTRODUCTION	
1.1 Description	3
1.2 Specifications	3
1.3 Signal Flow	3
2. CIRCUIT DESCRIPTIONS	
2.1 Noise Generator	4
2.2 LFO (Low Frequency Oscillator)	4
2.3 Gate Generator	4
2.4 KYBD. Current Source	4
2.5 CV Memory	4
2.6 ADSR Envelope Generator	5
2.7 VCA (Voltage Controlled Amplifier)	5
2.8 VCO (Voltage Controlled Oscillator)	6
2.9 VCF (Voltage Controlled Filter)	6
2.10 Basic Axxe 'Patch'	6
3. BOARD TRIMS & ADJUSTMENTS	7
4. BOARD TEST POINTS	8
5. INTERFACING INFORMATION	
5.1 Master/Slave Tuning Instructions	10
5.2 Systems Interfacing With Other ARP Synthesizers	10
6. AXXE DRAWINGS	
6.1 Axxe Board Layout	11, 13
6.2 Axxe Board Schematics	12, 14
7. AXXE POWER SUPPLY INFORMATION	
7.1 Power Supply Circuit Descriptions	15
7.2 Power Supply Schematic	16
7.3 Power Supply Board Layout	17
8. AXXE PARTS LIST	18
9. SERVICE REVISIONS	19

ARP INSTRUMENTS, INC.
45 Hartwell Avenue
Lexington, MA 02173