

SERVICE MANUAL & PARTS LIST

ELECTRONIC KEYBOARD

CZ-1

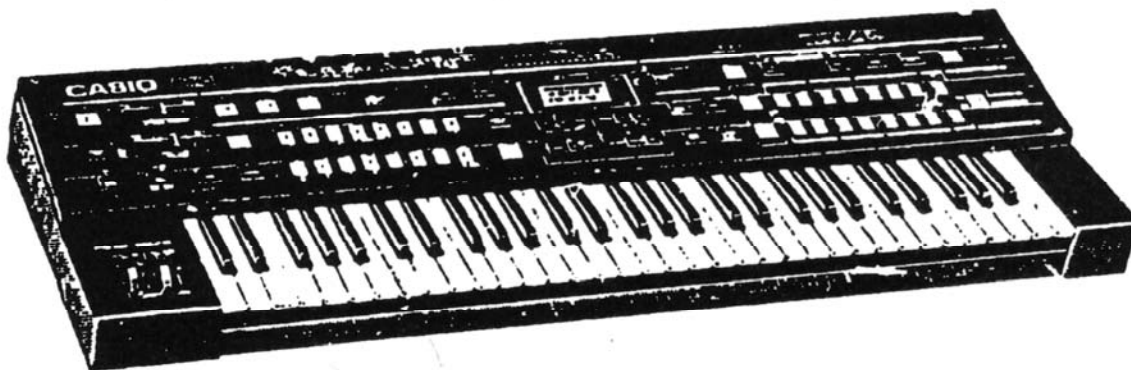

CZ-1

CASIO.

CAUTION:

When the connector ○ (from the lithium battery) is disconnected, all the sound data in the Memory Bank are cleared. When this happens, initialize the unit by the following procedures.

1. Turn the power switch off and press INITIALIZE button.
2. Turn the power switch on, then the display indicates;

SYSTEM ALL
INITIALIZE(Y/N)?

3. While pushing INITIALIZE button, press YES button on the data entry section of the panel. All the Memory Bank data are initialized, then the display shows:

SYSTEM
INITIALIZED !!

CONTENTS
CZ-1 Service Manual

	Fiche #	Cell #
1. SCHEMATIC DIAGRAM		
1-1. Main PCB (A) M5154-MA1M, IF	1	3-A5
1-2. Main PCB (B) M5154-MA1M	2	3-A7
1-3. Stereo Chorus Circuit PCB M5154-MA2M	3	3-A9
1-4. MIDI Control & Amp. Block PCB M5154-MA3M, AS1M	4	3-A11
1-5. LED Drive Circuit PCB M5154-MA4M	5	3-A13
1-6. Power Supply Circuit PCB M5154-PS1, PS2	6	3-B1
1-7. Panel Block PCB (A) M5154-CN1M, CN3M	7	3-B3
1-8. Panel Block PCB (B) M5154-CN2M	8	3-B5
1-9. Keyboard PCB M571-KY1M, KY3M, M5177-KY2M	9	3-B7
2. WIRING DIAGRAM	10	3-B9
3. PCB VIEW & MAJOR CHECKPOINTS		
3-1. PCB M5154-MA1M	11	3-B11
3-2. PCB M5154-MA2M	12	3-B13
4. MAJOR WAVEFORMS	13	3-C1
5. BLOCK DIAGRAM	16	3-C4
6. DIGITAL CIRCUIT BLOCK DIAGRAM	17	3-C6
7. CPU (μPD7810H)		
7-1. Pin Functions of Main CPU	18	3-C7
7-2. Pin Functions of Sub CPU	19	3-C8
8. MAIN RAM & ROM ACCESSES	21	3-C10
9. SUB RAMs & ROM ACCESSES	22	3-C11
10. CPU INTERFACE LSI (MB64H173)		
10-1. Function of Each Block	24	3-C13
10-2. Data Transfer Procedures	25	3-C14
10-3. Switch Matrix	29	3-D4
11. KEYBOARD		
11-1. Key Touch Speed Detection	30	3-D5
11-2. Key Matrix	31	3-D6
11-3. Pin Functions of Key Touch Control LSI (MSM6200)	32	3-D7
11-4. Pin Functions of Key Interface LSI (μ PD8049HC)	32	3-D7
11-5. Key Touch Data Communication	33	3-D8
11-6. After Touch Control Circuit	35	3-D10
12. DATA CLOCK PULSE GENERATOR	36	3-D11
13. LED DRIVING CIRCUITS	37	3-D12
14. ANALOG CIRCUIT BLOCK DIAGRAM	39	3-D14
15. MUSIC LSIs ACCESSES	41	3-E2
16. PIN FUNCTION OF MUSIC LSI (μPD933AC)	42	3-E3

CZ-1 Service Manual

17.	DAC (Digital to Analog Converter) CIRCUIT	43	3-E4
18.	EXPANDER CIRCUIT	44	3-E5
19.	SAMPLE & HOLD CIRCUIT	48	3-E7
20.	STEREO CHORUS CONTROL CIRCUITS		
20-1.	Block Diagram	47	3-E8
20-2.	Signal Function	47	3-E8
20-3.	Circuit Function	48	3-E9
20-4.	Line-out Circuit	48	3-E9
21.	STEREO CHORUS CIRCUIT		
21-1.	Block Diagram	50	3-E11
21-2.	Function of Each Block	51	3-E13
21-3.	Three-Phase LFO (Low Frequency Oscillator)	52	3-E14
21-4.	VCO (Voltage Controlled Oscillator)	53	3-F1
21-5.	BBD (Bucket Brigade Device)	54	3-F2
21-6.	Compressor and Expander Circuits	55	3-F3
22.	OUTPUT VOLUME CONTROL CIRCUIT	56	3-F4
23.	RESET CIRCUIT	57	3-F5
24.	MIDI INTERFACE CIRCUIT	58	3-F6
25.	ADJUSTMENT		
25-1.	DAC Offset Voltage Adjustment	59	3-F7
25-2.	VSS1 Voltage Adjustment (Power Source for MSM6200)	59	3-F7
25-3.	LCD Brightness Adjustment	59	3-F7
25-4.	After Touch Adjustment	59	3-F7
25-5.	VCA Offset Voltage Adjustment	60	3-F8
25-6.	BBD Adjustment	60	3-F8
25-7.	Volume Adjustment	61	3-F9
	Parts List	62	3-F10
	Parts Diagrams	66	3-G11/13
	Enlarge Schematics of M5154-MA1M, MA2M, MA3M, AS1M on Fiche 4		B1, B4, B7, B10
	Operation Manual		4-C1
	Technical News Bulletin / 85		4-A13
	Preset Tone Data	Fiche 5	
	System MIDI Exclusive	Fiche 6	

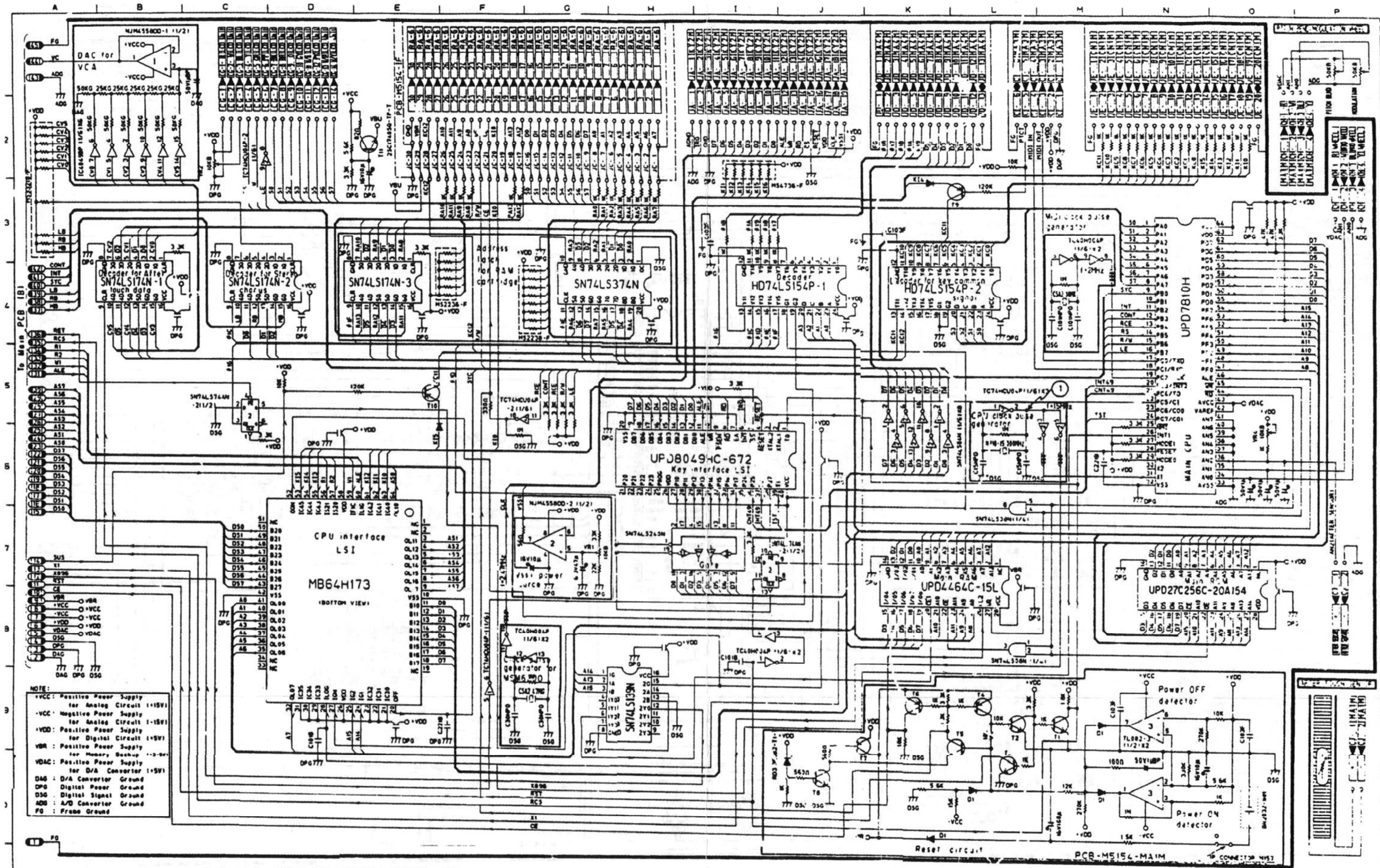

1-1 Main PCB (A) M5154-MA1M, IF

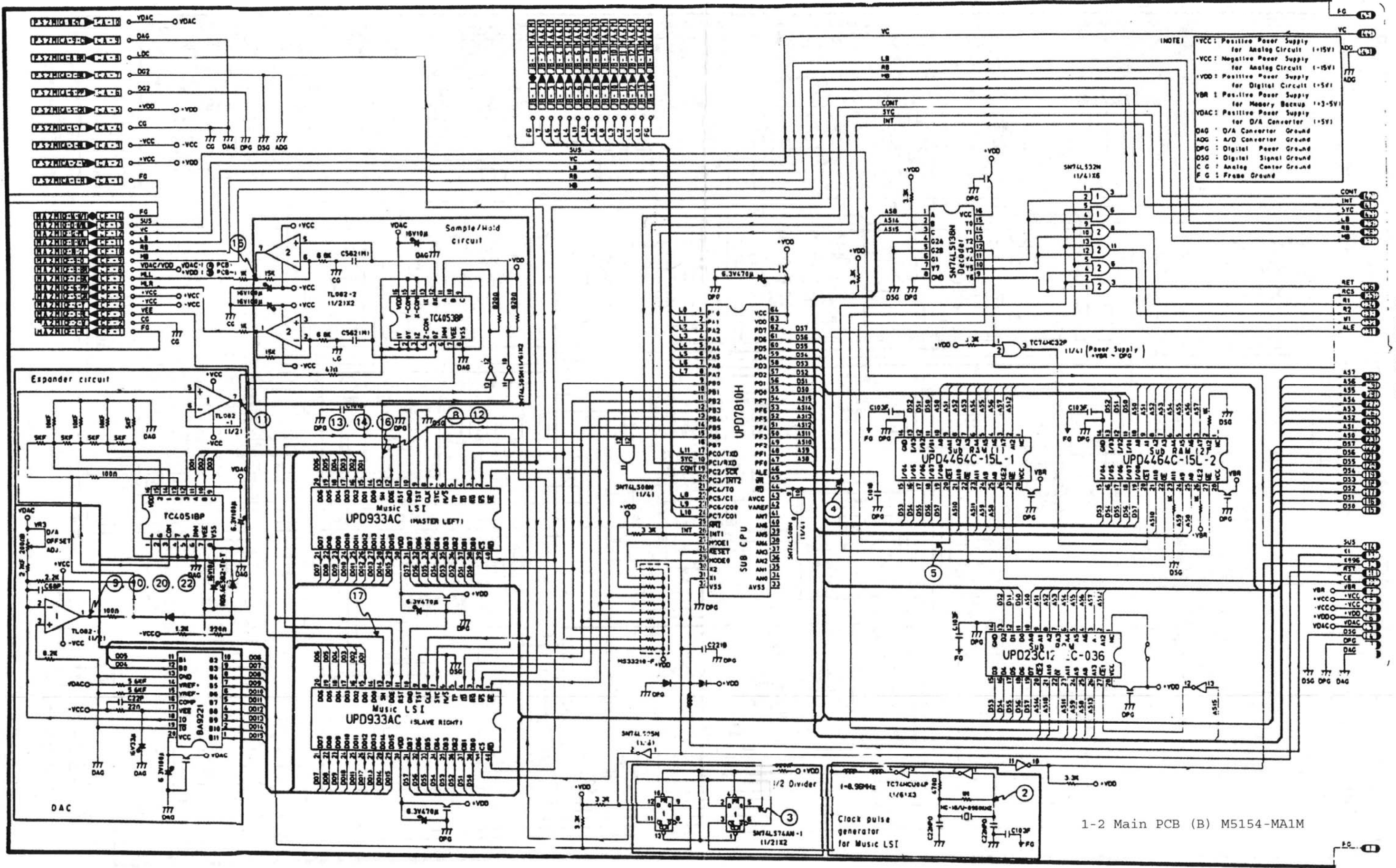

1-2 Main PCB (B) M5154-MA1M

To Main PCB (A1)

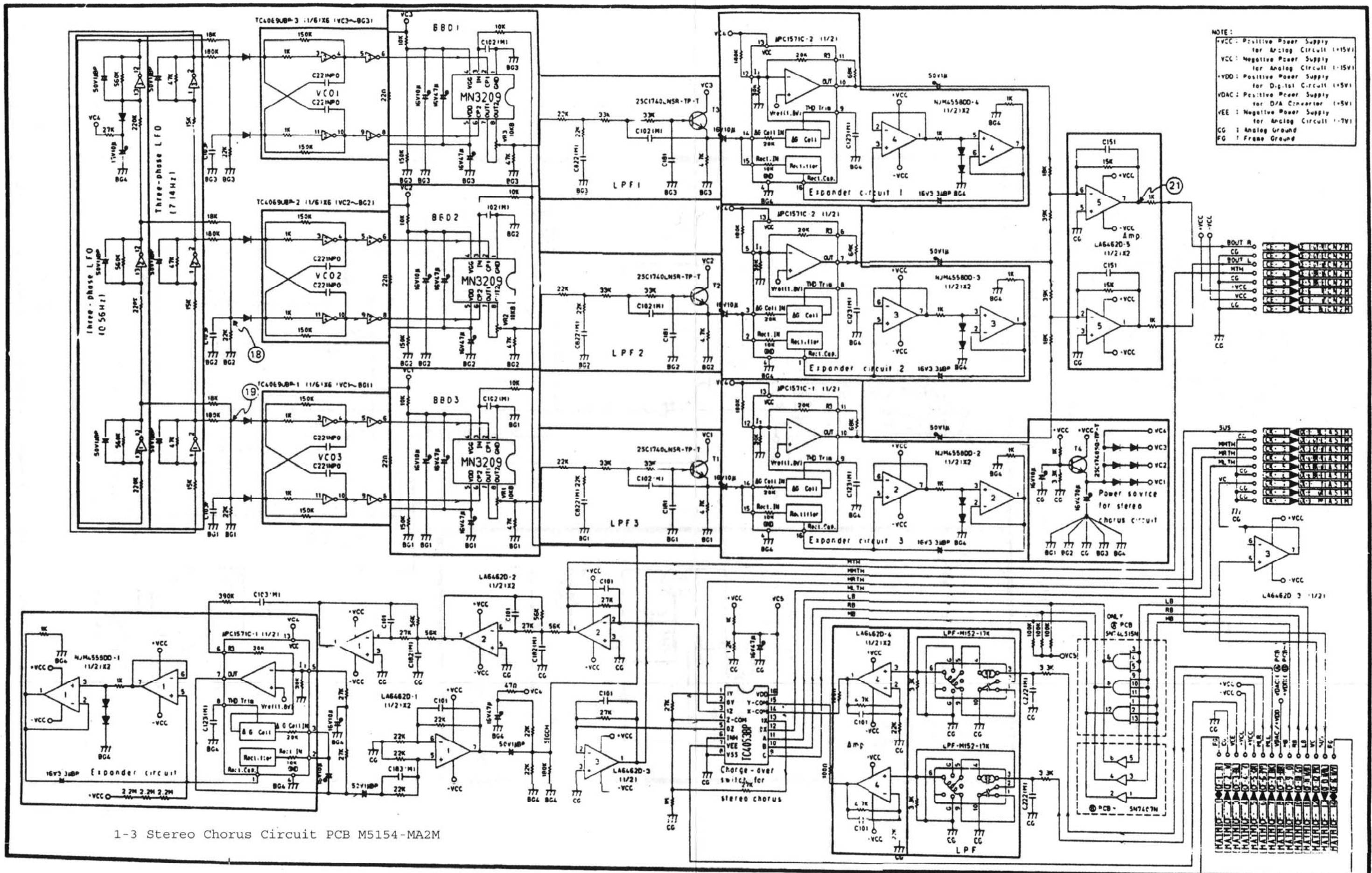

NOTE:
 +VCC: Positive Power Supply for Analog Circuit (+15V)
 -VCC: Negative Power Supply for Analog Circuit (-15V)
 +VDD: Positive Power Supply for Digital Circuit (+5V)
 -VDD: Negative Power Supply for Digital Circuit (-5V)
 +VAC: Positive Power Supply for D/A Converter (+5V)
 -VEE: Negative Power Supply for Analog Circuit (-7V)
 CG: Analog Ground
 FG: Frame Ground

1-3 Stereo Chorus Circuit PCB M5154-MA2M

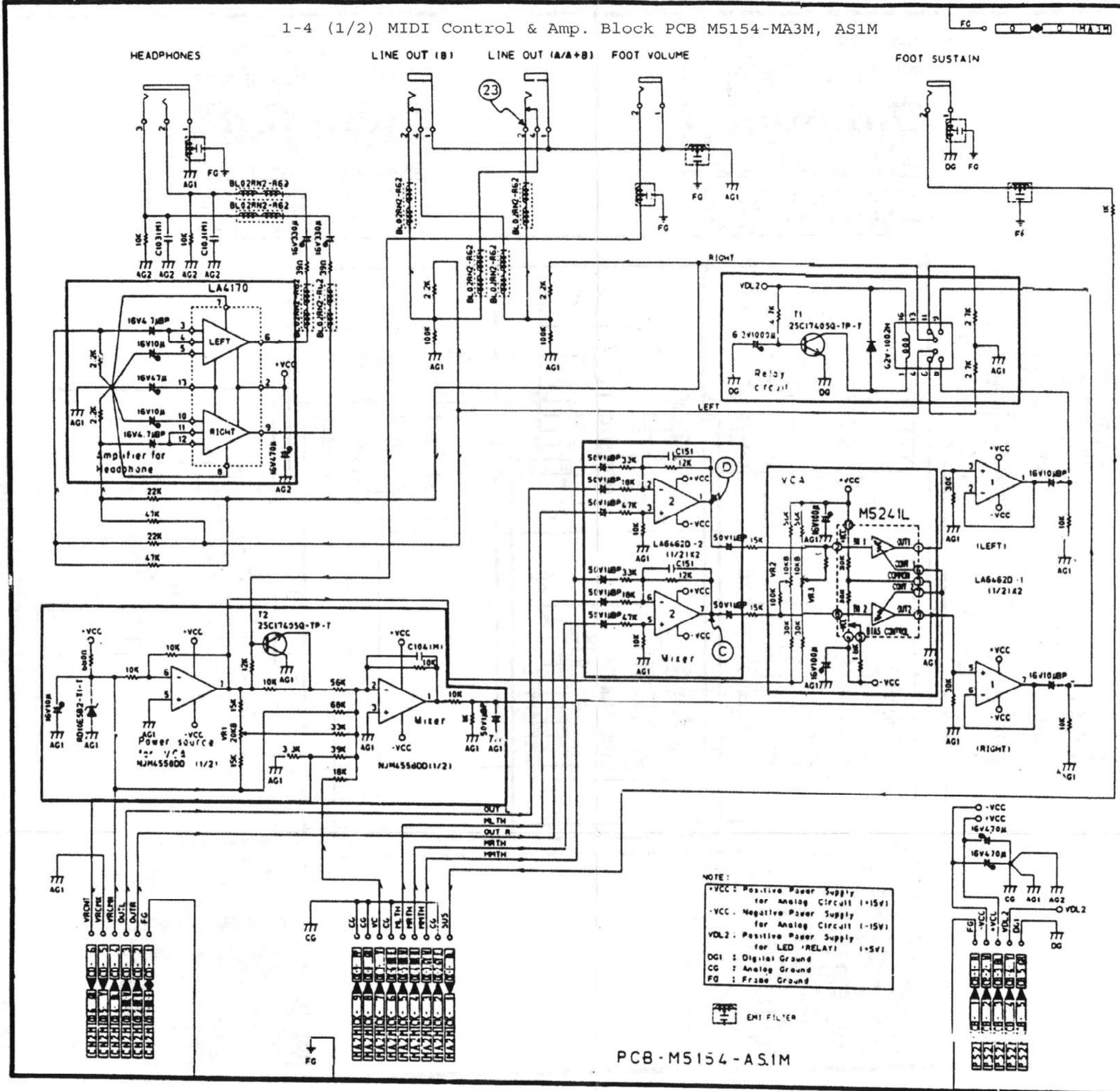

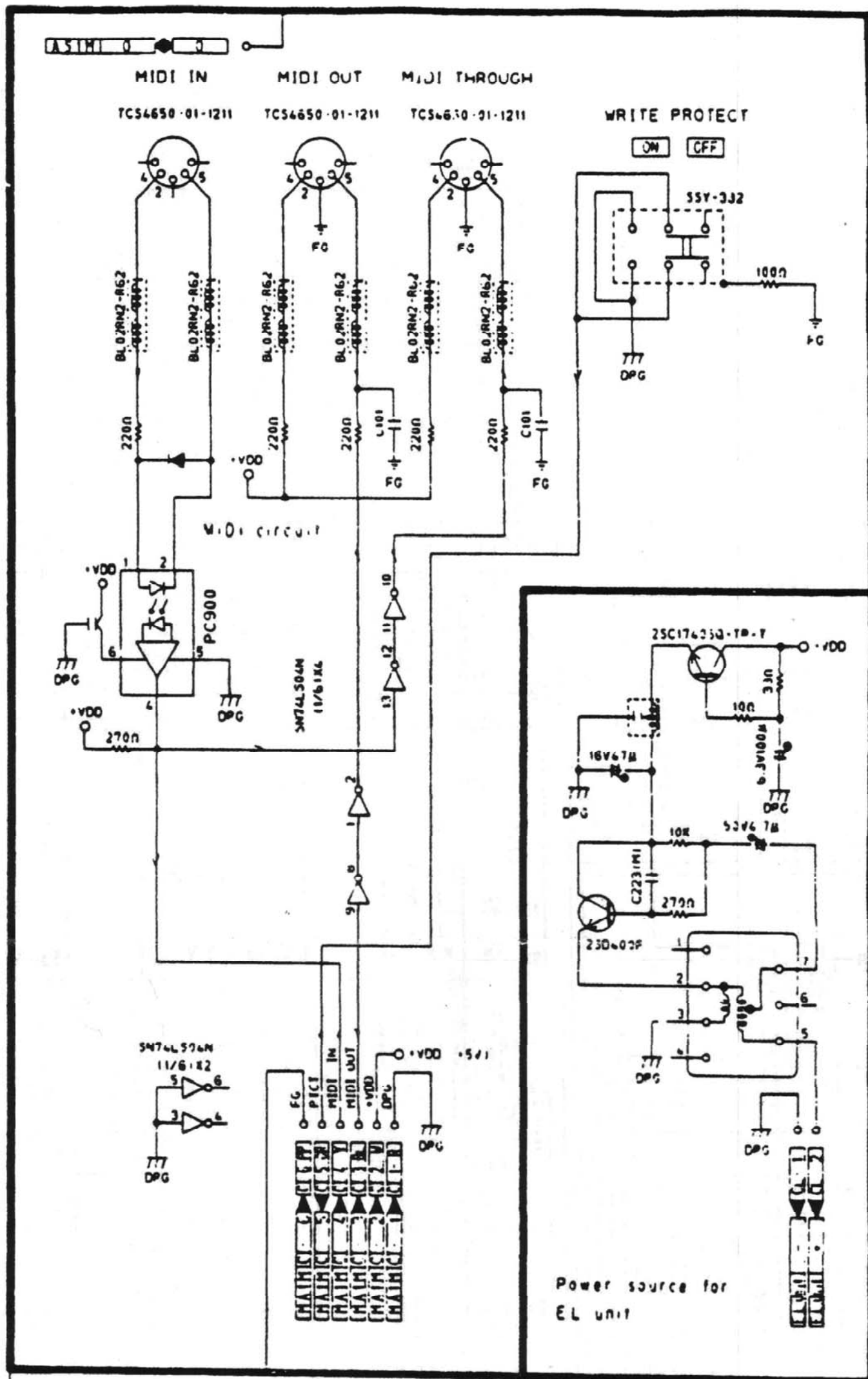

LCD UNIT

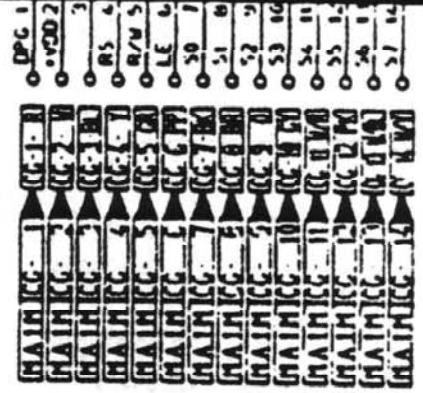

LCD UNIT

E.L. Unit



1-4 (2/2) MIDI Control & Amp. Block PCB M5154-MA3M, AS1M

1-5 LED Drive Circuit
PCB M5152-MA4M

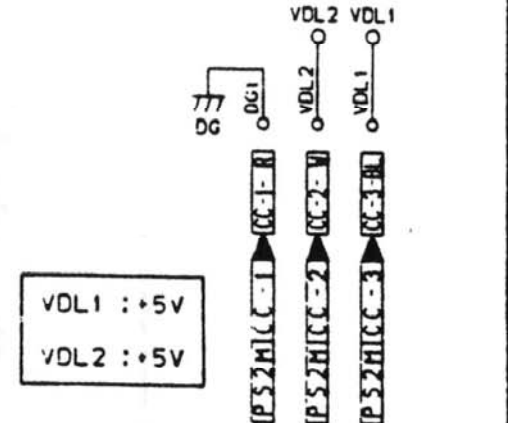
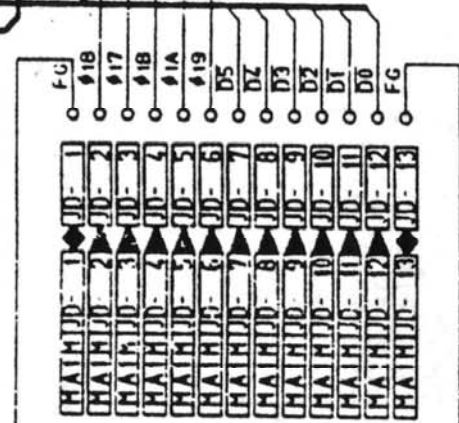
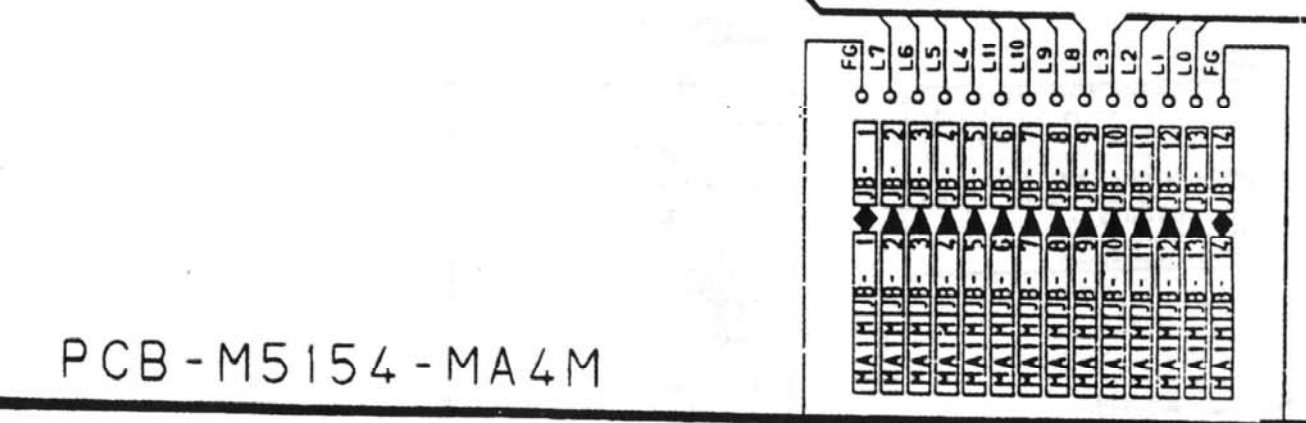
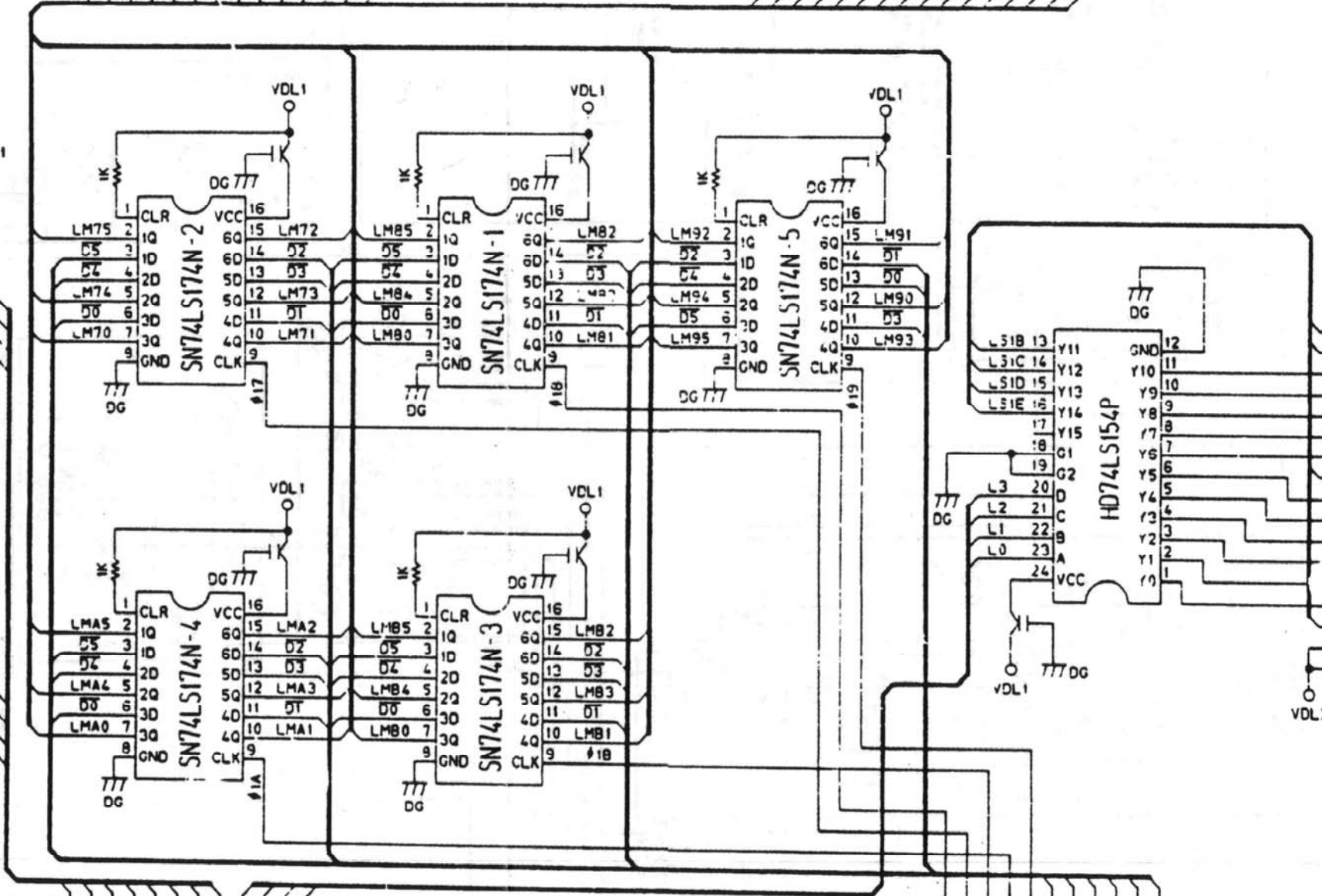
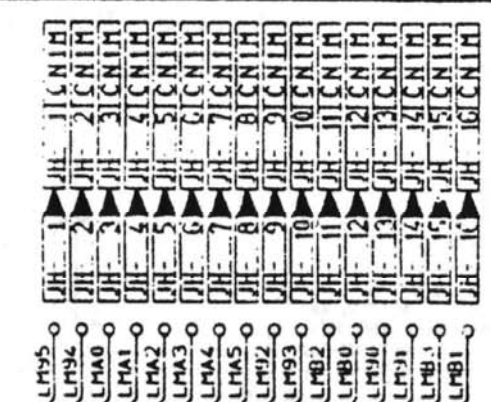
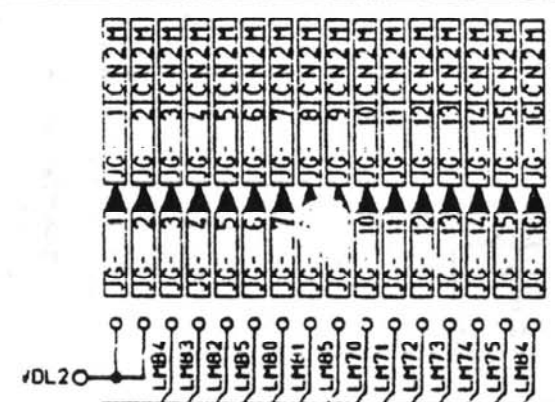
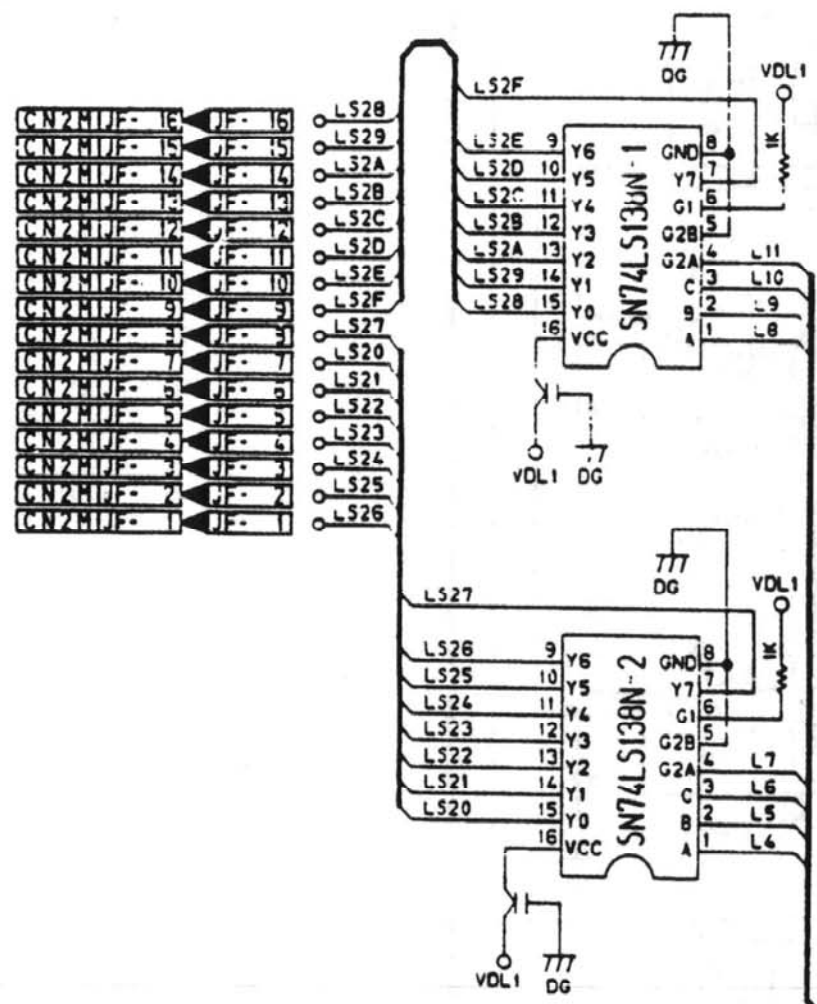

PCB-M5154-MA4M

FUSE

AA	
USA Universal type	
F1	MTL 1A 250V
F2	LA TSC 2A 125V
F3	LA TSC 0.5A 125V
F4	LA TSC 0.5A 125V
C1	CA
C2	CA

INOTE: CA: DE7150F7103PVA1

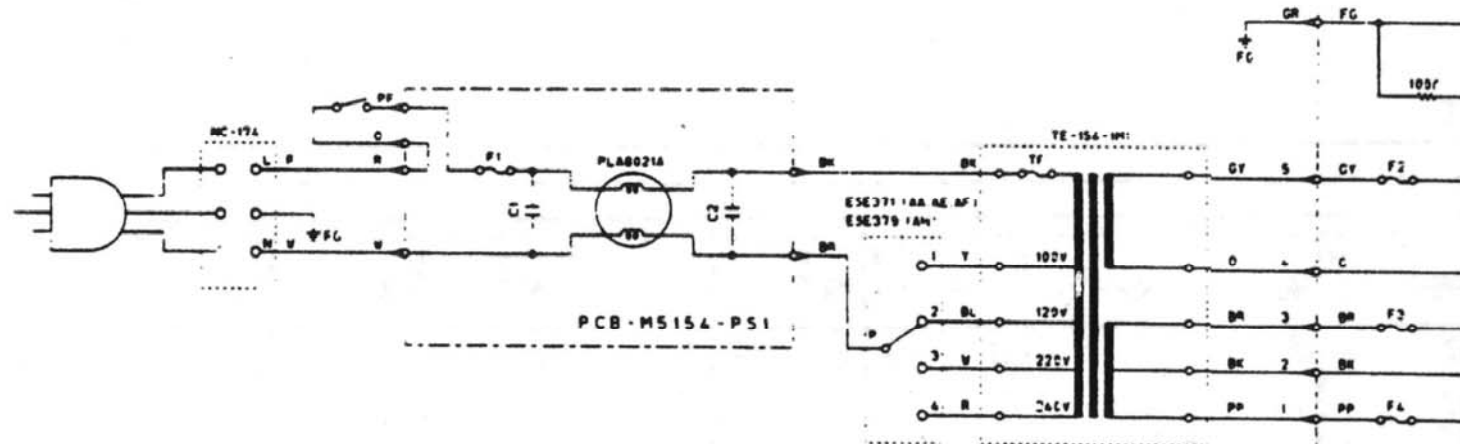

PCB-M5154-PS1

NOTE:
 +VCC: Positive Power Supply for Analog Circuit +15V
 -VCC: Negative Power Supply for Analog Circuit -15V
 +VDD: Positive Power Supply for Digital Circuit +5V
 VOL1: Positive Power Supply for LED Driver +5V
 VOL2: Positive Power Supply for LED +5V
 VDNC: Positive Power Supply for D/A Converter +5V
 DAC: D/A Converter Ground
 DG1: Digital Ground 1
 DG2: Digital Ground 2
 CL: Analog Ground
 FG: Frame Ground

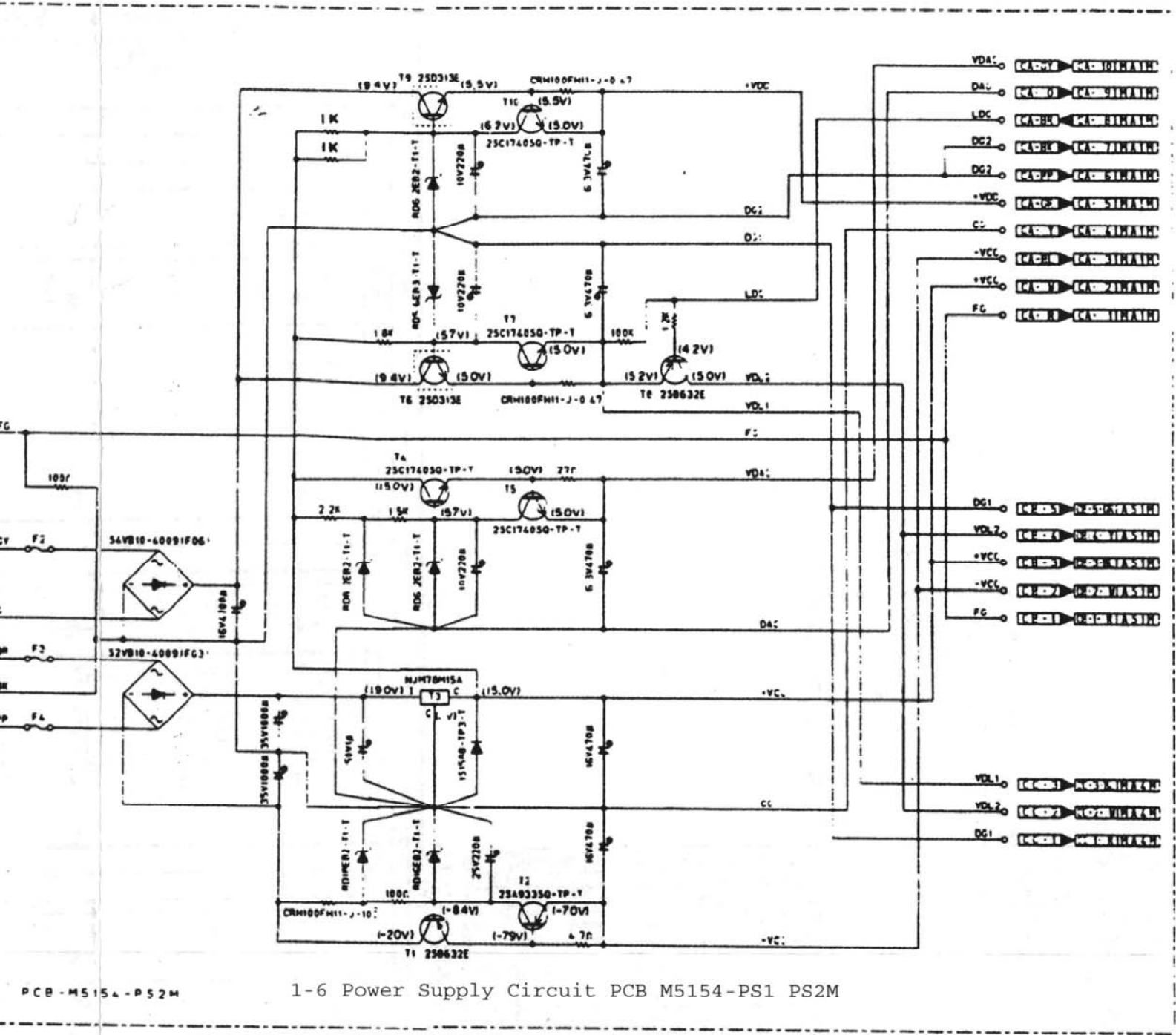

PCB-M5154-PS2M

1-6 Power Supply Circuit PCB M5154-PS1 PS2M

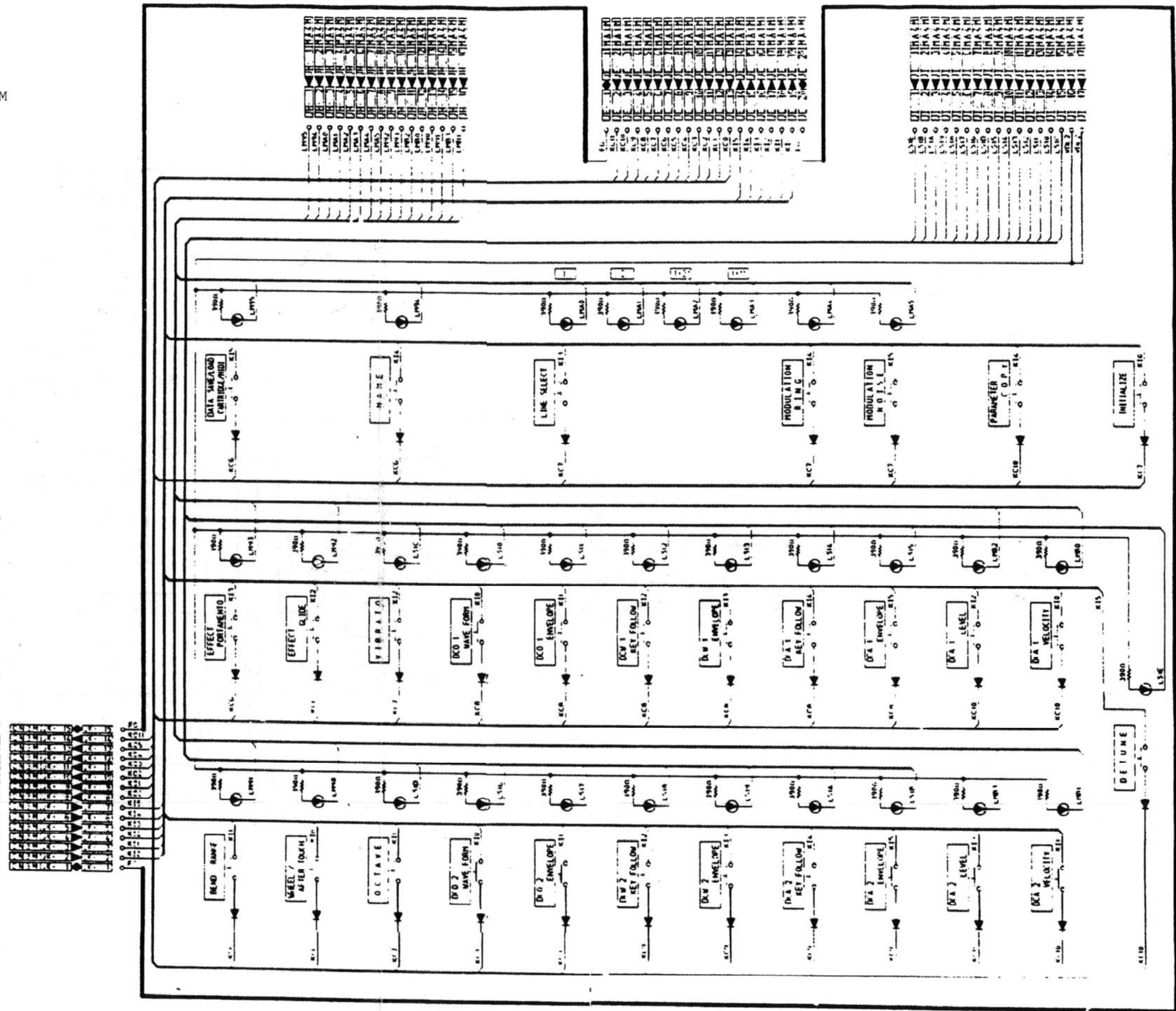
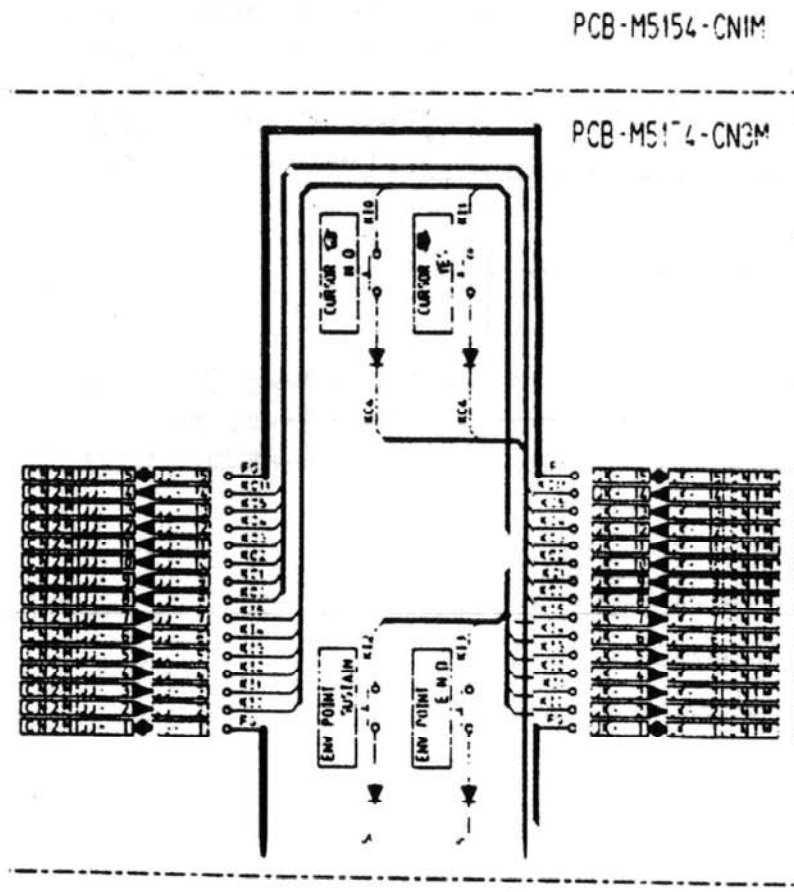

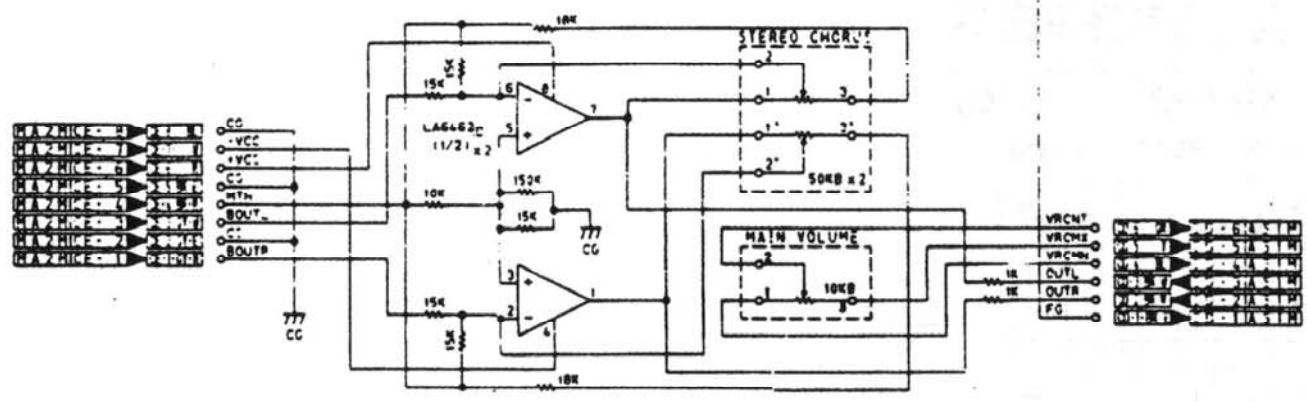

1-8 Panel Block PCB (B) M5154-CN2M

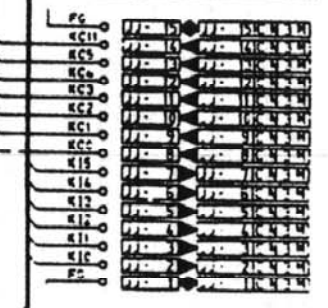
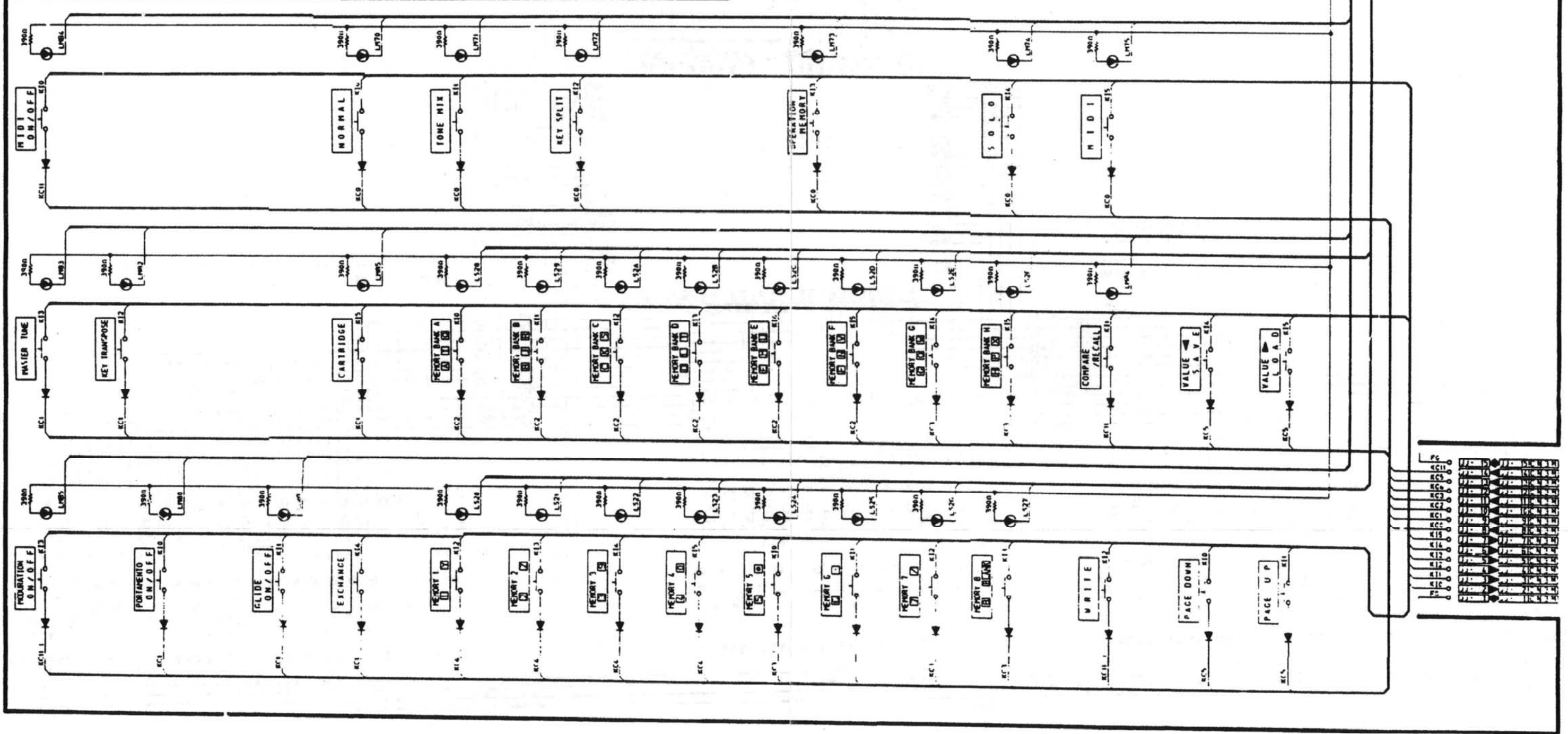
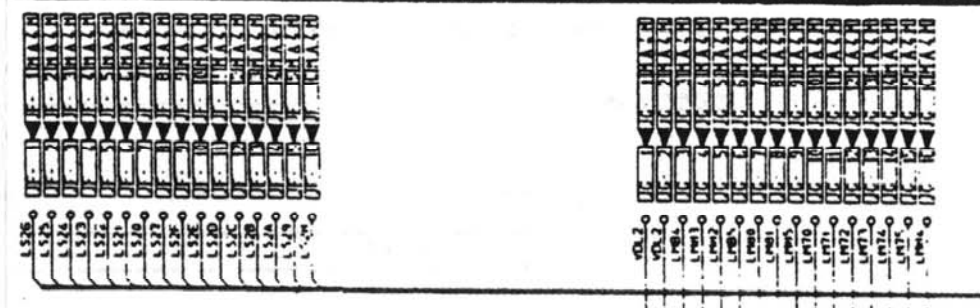

1-9 Keyboard PCB M571-KY1M, KY3M, M5177, KY2M

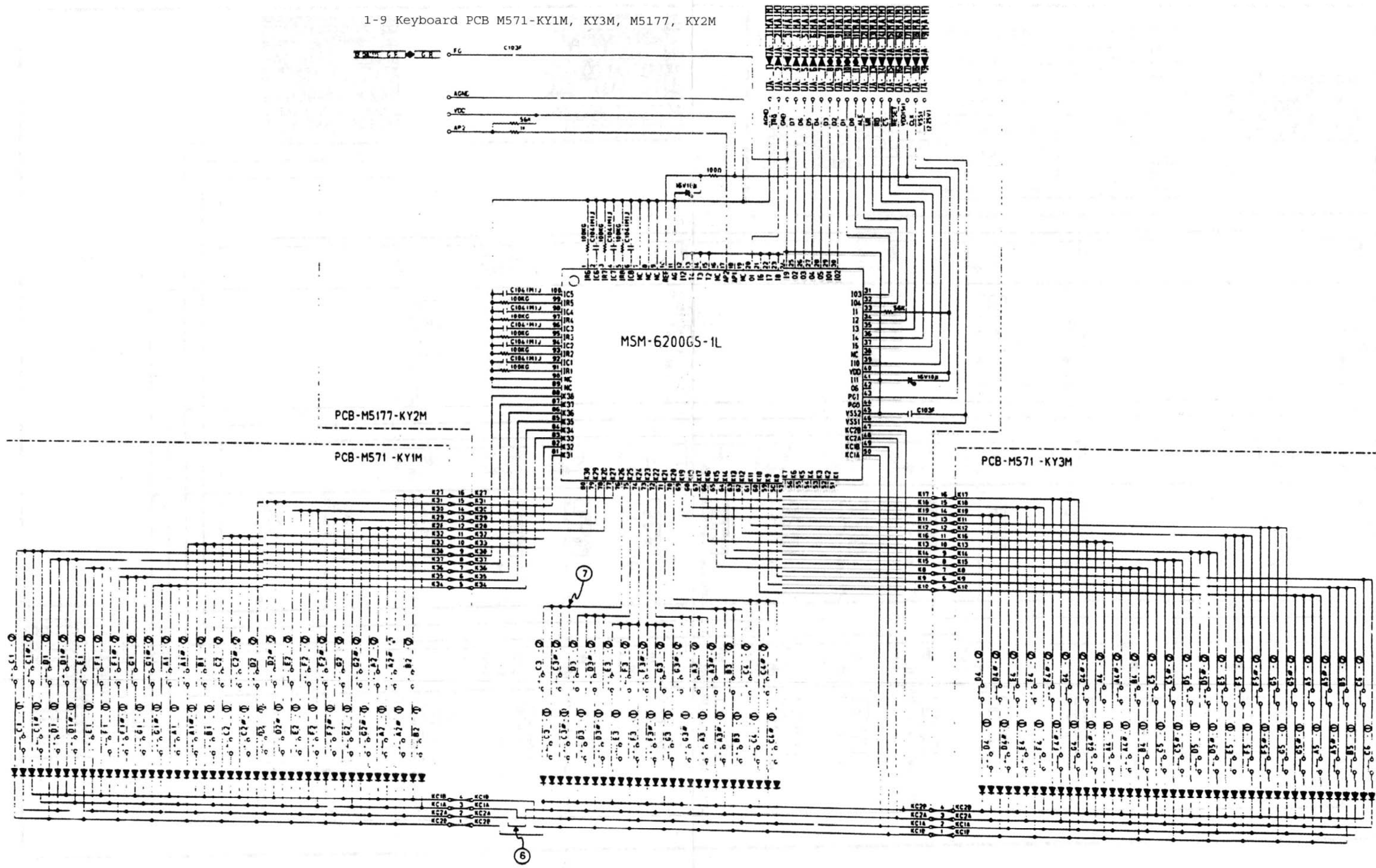

NOTE: 1. Wire Color Codes

R : Red	W : White	BL: Blue
Y : Yellow	GR: Green	PP: Purple
BK: Black	BR: Brown	O : Orange
GY: Gray	PK : Pink	E : Shielded wire

2. Terminal Readings

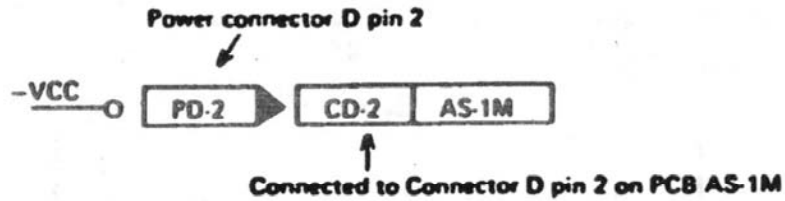
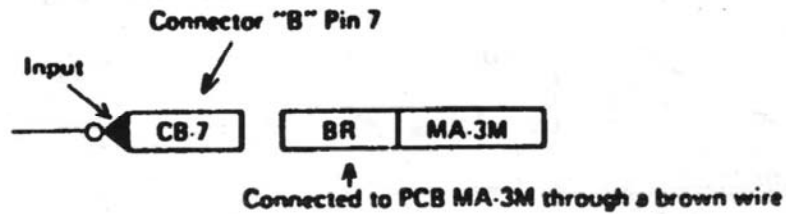
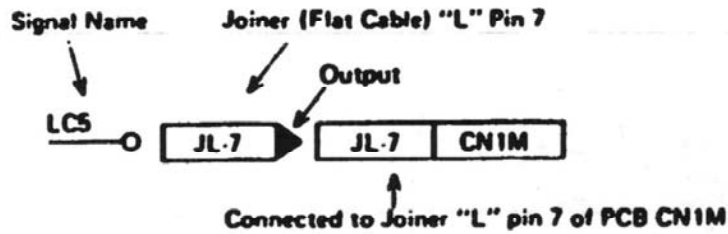

3. Voltage Levels

VDD	+5V	For digital circuits
VDL1	+5V	For LED driving
VDL2	+5V	For LED driving (rises to +5V approximately 830 milliseconds after Power ON)
VDAC	+5V	For DAC (Digital to Analog Converter)
+VCC	+15V	For analog circuits
-VCC	-15V	For analog circuits
DG	0V	Digital ground
FG	0V	Frame ground
DAG	0V	DAC ground
CG	0V	Analog ground
VBR	+5V at Power ON +3V at Power OFF	RAMs' back.up voltage

3. PCB VIEW & MAJOR CHECKPOINTS

3-1. PCB M5154-MA1M

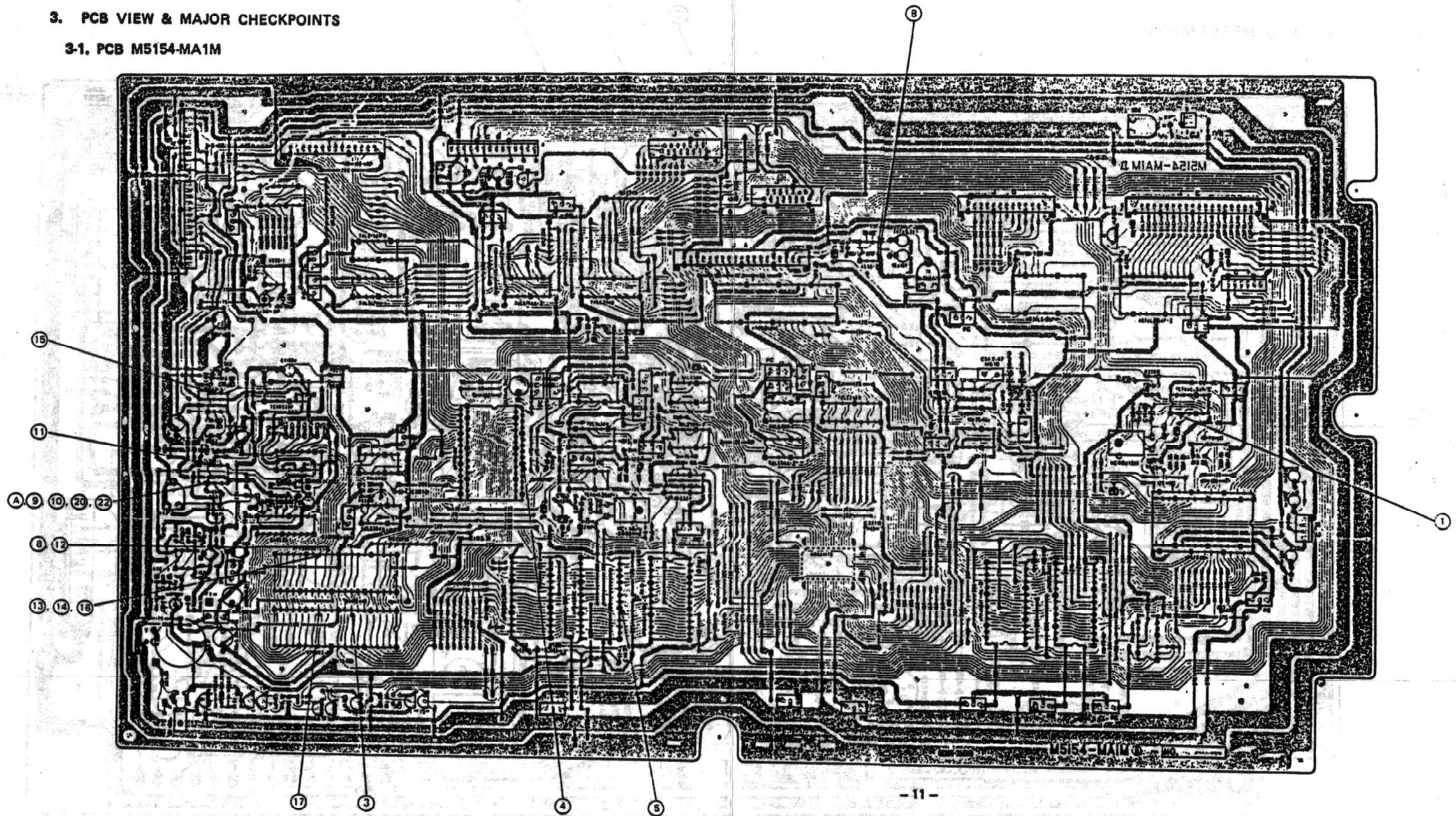

3-2. PCB M5154-MA2M

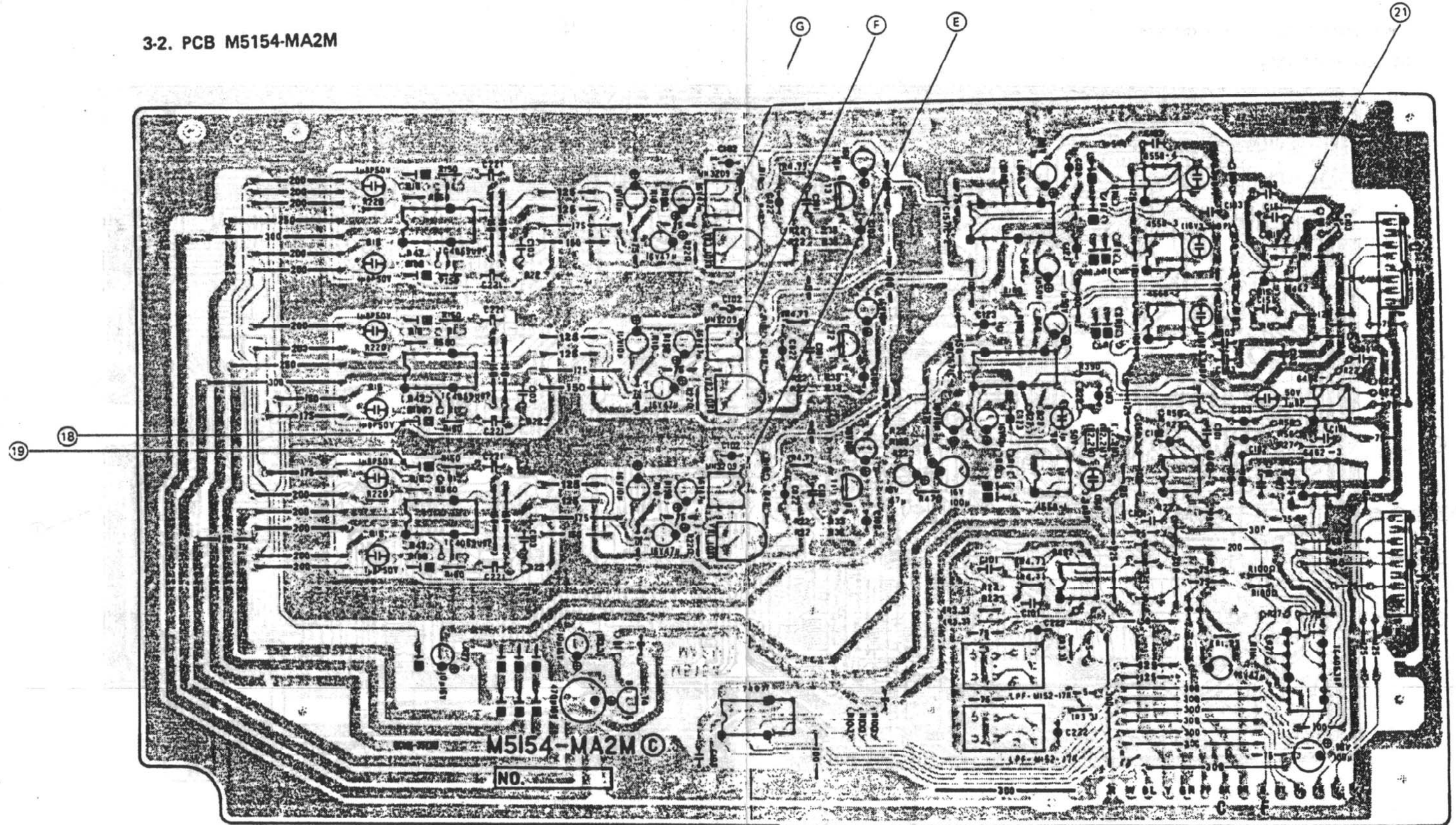

G

F

E

21

18

19

M5154-MA2M ©

NO. 1

300

W O L Y G N T U C B C A

4. MAJOR WAVEFORMS

Notes: Photographs marked (M) show stored waveforms in a memory scope.
 The analog waveforms were observed via a 28 Kohm resistor.
 Probe reduction; 10:1

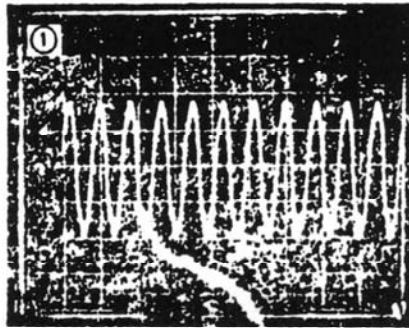
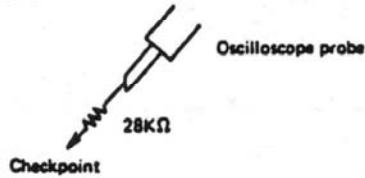

① μ PD7810H clock pulse
 PCB M5154-MA1M
 TC74HC04P-2 pin 2
 0.1 μ S/div, 0.2V/div

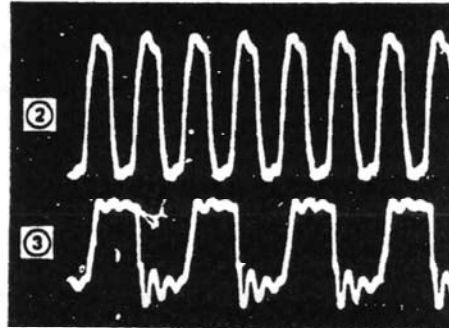

② μ PD8049HC clock pulse
 PCB M5154-MA1M
 TC74HC04P-1 pin 11
 0.1 μ S/div, 0.2V/div

③ μ PD833AC clock pulse
 PCB M5154-MA1M
 μ PD833AC pin 8
 0.1 μ S/div, 0.2V/div

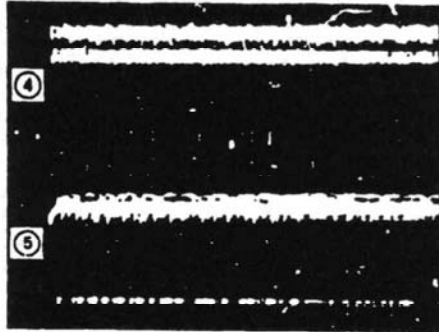

④ μ PD7810H \overline{WR} signal
 PCB M5154-MA1M
 μ PD7810H (SUB) pin 45
 5 μ S/div, 0.2V/div

⑤ μ PD4454C \overline{CE} signal
 PCB M5154-MA1M
 μ PD4454C-15L-1 pin 20
 5 μ S/div, 0.2V/div

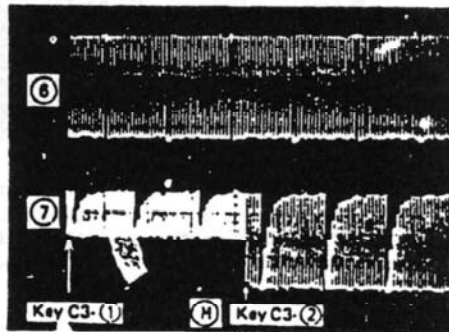

⑥ Key common signal
 PCB M5177-KY2M
 Refer to page 9
 0.2mS/div, 0.2V/div

⑦ Key input signal
 PCB M5177-KY2M
 Refer to page 9
 0.2mS/div, 0.2V/div

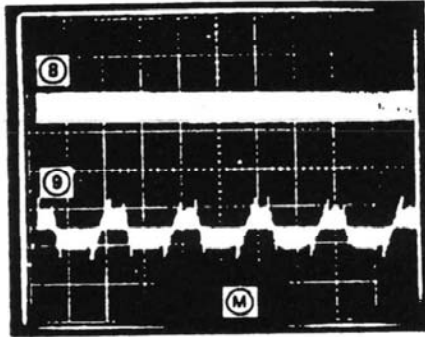

⑧ μ PD833AC DOE signal
 PCB M5154-MA1M
 μ PD833AC pin 12
 2mS/div, 0.5V/div

⑨ DAC output
 PCB M5154-MA1M
 TL082-1 pin 1
 10 μ S/div, 0.5V/div

Tone: Flute, Key: C4

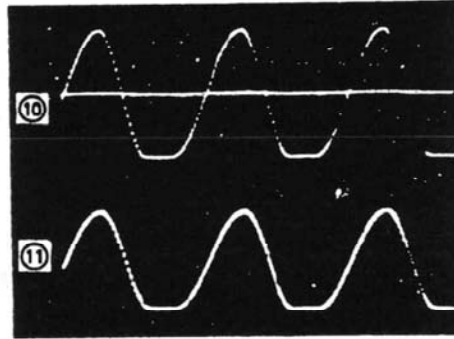

⑩ DAC output
 PCB M5154-MA1M
 TL082-1 pin 1
 5mS/div, 0.2V/div

⑪ Expander circuit output
 PCB M5154-MA1M
 TL082-1 pin 7
 5mS/div, 50mV/div

Tone: Flute, Key: C4

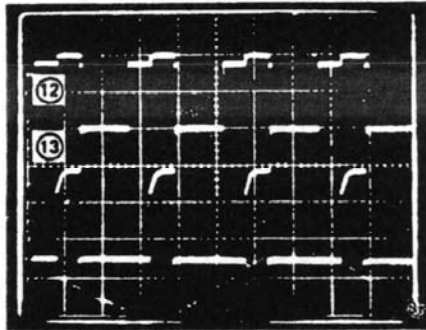

⑫ μ PD833AC (M) DOE signal
 PCB M5154-MA1M
 μ PD833AC (M) pin 12
 10 μ S/div, 0.2V/div

⑬ μ PD833AC (M) SH signal
 PCB M5154-MA1M
 μ PD833AC (M) pin 13
 10 μ S/div, 0.2V/div

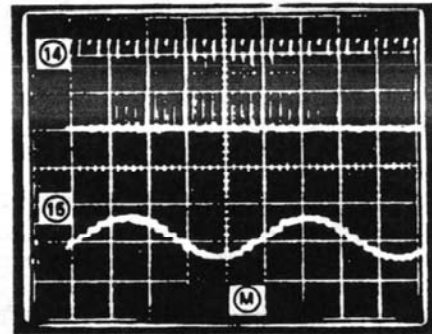

⑭ μ PD833AC (M) SH signal
 PCB M5154-MA1M
 μ PD833AC (M) pin 13
 0.1 μ S/div, 0.2V/div

⑮ Sample/Hold circuit output
 PCB M5154-MA1M
 TL082-2 pin 7
 0.1 μ S/div, 2V/div

Tone: Flute, Key: C7

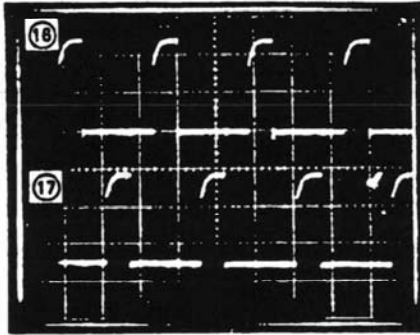

⑩ μ PD933AC (M) SH signal
PCB M5154-MA1M
 μ PD933AC (M) pin 13
10 μ S/div, 0.2V/div

⑪ μ PD933AC (S) SH signal
PCB M5154-MA1M
 μ PD933AC (S) pin 13
10 μ S/div, 0.2V/div

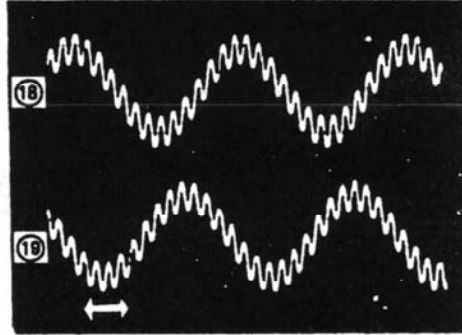

⑫ LFO1 output
PCB M5154-MA2M
Refer to page 12
0.5S/div, 0.1V/div

⑬ LFO2 output
PCB M5154-MA2M
Refer to page 12
0.5S/div, 0.1V/div

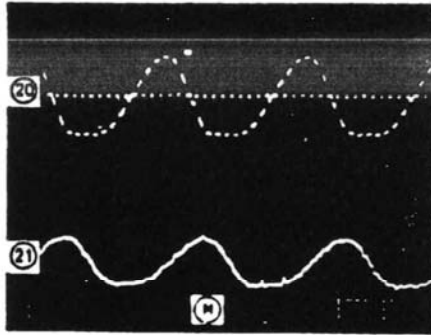

⑭ DAC output
PCB M5154-MA1M
TL082-1 pin 1
0.5mS/div, 0.2V/div

⑮ Stereo chorus output
PCB M5154-MA2M
LA8462D-5 pin 7
0.5mS/div, 5mV/div

Tone: Flute, Key: A3

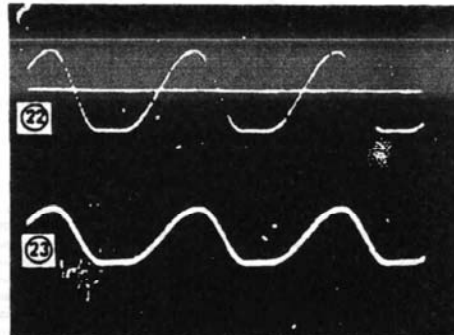

⑯ DAC output
PCB M5154-MA1M
TL082-1 pin 1
0.5mS/div, 0.2V/div

⑰ LINE-OUT output
A/A+B LINE-OUT terminal
0.5mS/div 10mV/div

Tone: Flute, Key: A3, Volume: Max., Stereo chorus: OFF

5. BLOCK DIAGRAM

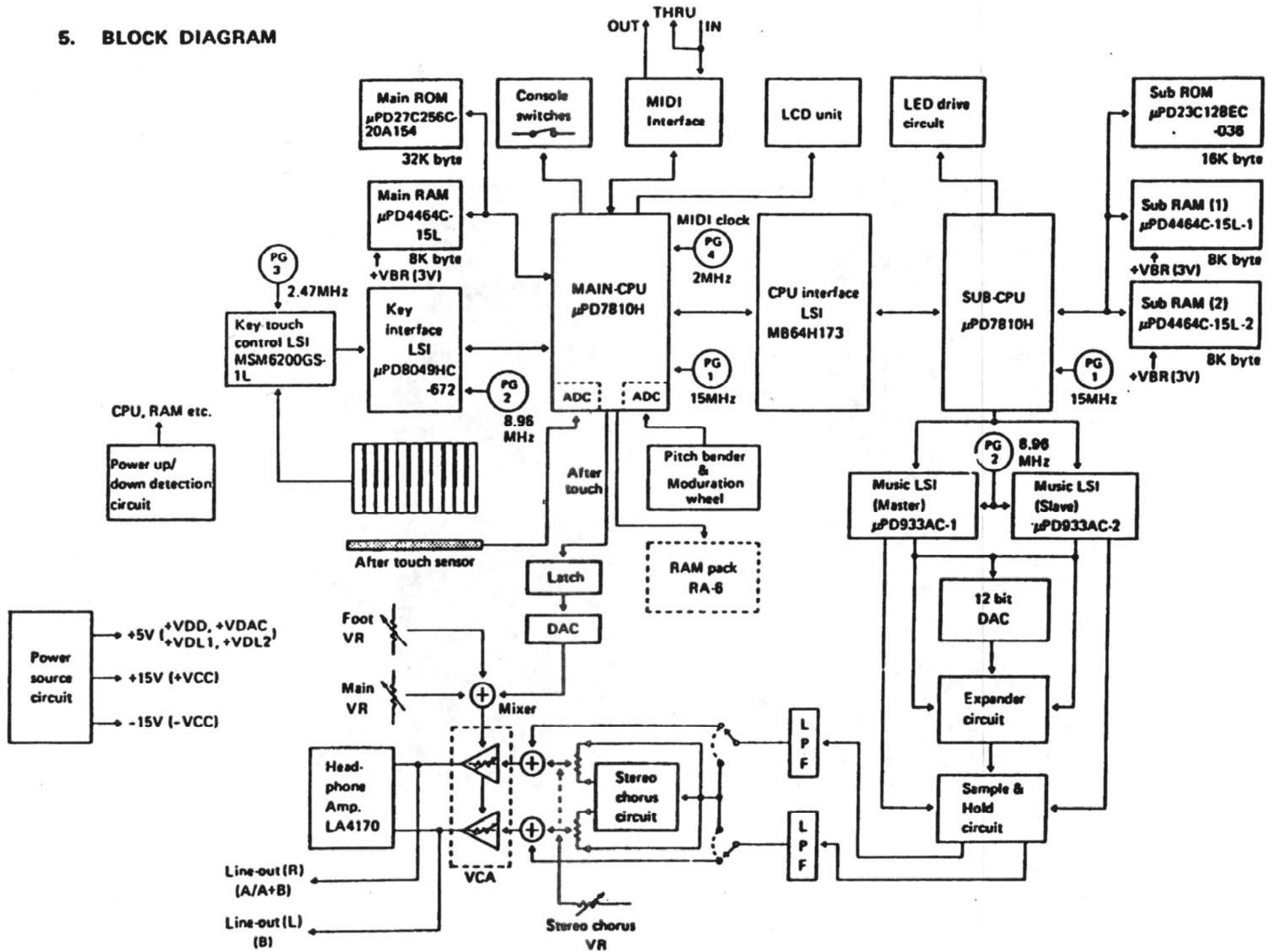

6. DIGITAL CIRCUIT BLOCK DIAGRAM

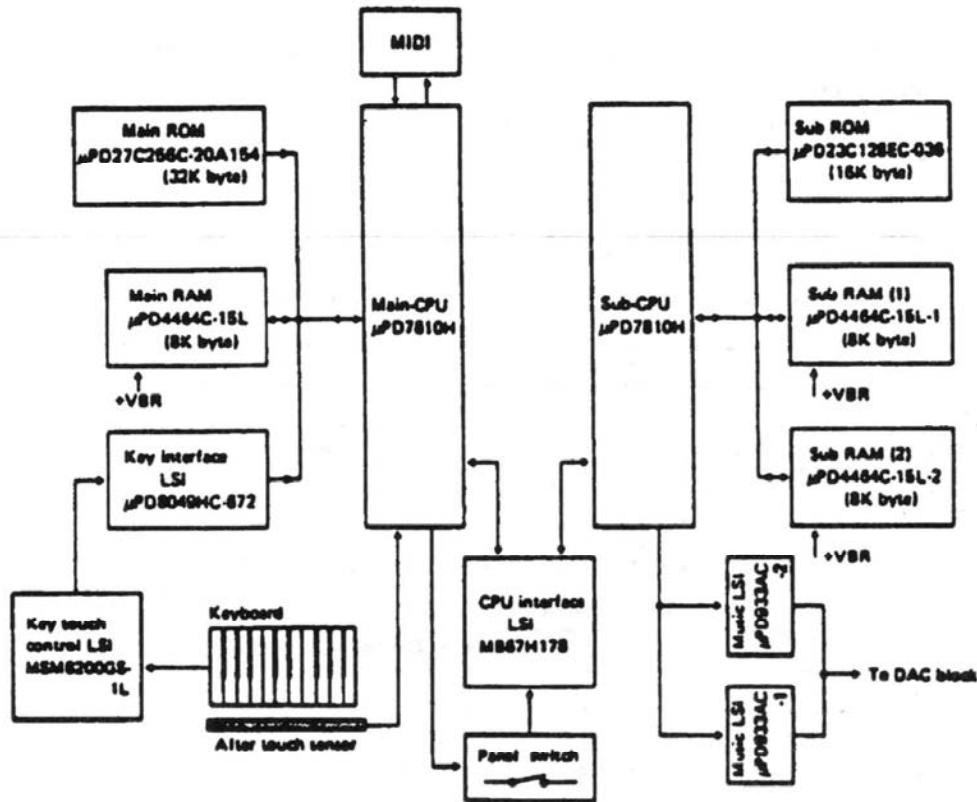

CZ-1 employs five control LSIs for quick processing.

(1) Main CPU Block

The block mainly controls operation of the digital circuits.

Main CPU Controls keys, switch scanning, memory devices and MIDI.

Main ROM Contains program for system execution.

Main RAM Has work area for system execution and stores operation memories and tone name data.

Key interface LSI A buffer for data communication between CPU and Key touch control LSI.

Key touch control LSI Detects key entry and initial key touch speed.

(2) Sub CPU Block

The block mainly controls music LSIs.

Sub CPU Controls music LSIs and memory devices.

Sub ROM Contains program for system execution and data for preset tones.

Sub RAM (1) Stores data area for created sound.

Sub RAM (2) Work area for system execution.

Music LSIs Refer to page 42.

(3) CPU Interface LSI Interfaces between Main CPU and Sub CPU.

7. CPU (μ PD7810H)

As CPU (μ PD7810H) does not have an internal ROM, it accesses control data for system execution from an external ROM directly.

Main CPU and Sub CPU have different functions.

7-1. Pin Functions of Main CPU

Pin No.	Terminal Name	In/Out	Function
1 ~ 8	PA0(S0) ~ PA7(S7)	In/Out	Data bus for LCD and RAM pack. Signal PA0~PA3 also generates key common signal.
9	PB0 (SYC)	In	Synchronous signal from CPU interface LSI (MB64H173).
11	PB2 (INT)	Out	Sub CPU interrupt signal.
12	PB3 (CONT)	In/Out	Control signal between Main and Sub CPUs.
13	PB4 (RCE)	Out	Chip enable signal for RAM pack.
14	PB5 (RS)	Out	Control signal for LCD unit.
15	PB6 (R/W)	Out	Read/Write signal for RAM pack and LCD unit.
16	PB7 (LE)	Out	Enable signal for LCD unit.
17	PC0 (TXD)	Out	MIDI (Musical Instrument Digital Interface) data output.
18	PC1 (RXD)	In	MIDI data input.
19	PC2 ($\overline{\text{SCK}}$)	In	MIDI clock pulse input.
20	PC3 (INT49)	In	Interrupt signal from Key interface LSI (μ PD8049HC).
21	PC4 (CNT49)	Out	Control signal of Key interface LSI (μ PD8049HC).
22	PC5 (CI)	In	Timing signal of data transmission between Main CPU and Key touch control LSI (MSM8200).
24	PC7 (TST)	Out	Check signal for internal ROM/RAM of Key interface LSI (μ PD8049HC) at power ON.
26	INT1 (X896)	In	Interrupt signal from Sub CPU.
28	$\overline{\text{RESET}}$	In	Reset signal input. CPU internal circuits are initialized when the terminal receives a LOW level pulse at power ON.
31	X1	In	15MHz clock pulse input.
32	Vss		Ground (0V) source.
33	AVss		Ground (0V) source for internal ADC (Analog to Digital Converter)
34	AN0	In	Modulation wheel input. Voltage level from modulation wheel is converted into digital data by built-in ADC.
35	AN1	In	Pitch bender wheel input. Voltage level from pitch bender wheel is converted into digital data by built-in ADC.
36	AN2	In	After touch sensor input. Voltage level from after touch sensor is converted into digital data by built-in ADC.
42	VAREF		Reference voltage (+5V) for built-in ADCs.
43	AVcc		+5V power source for built-in ADCs.
44	$\overline{\text{RD}}$	Out	Read signal output. Drops to LOW when Main CPU reads data from peripheral devices.

Pin No.	Terminal Name	In/Out	Function
45	\overline{WR}	Out	Write signal output. Drops to LOW when Main CPU writes data into peripheral devices.
46	ALE	Out	Address latch enable signal output. Data signals D0~D7 become address signals A0~A7 when the terminal rises to HIGH.
47~54	PF0 (A8) ~ PF7 (A15)	Out	Upper address signals (A8 ~ A15).
55~62	PD0 (D0) ~ PD7 (D7)	In/Out	Data signals (D0 ~ D7).
63, 64	VDD, Vcc		+5V power source.

7-2. Pin Functions of Sub CPU

Pin No.	Terminal Name	In/Out	Function
1 ~ 8	PA0 (L0) ~ PA7 (L7)	Out	LED drive signals output.
9	PB0	In	Interrupt request signal input from Master Music LSI.
10	PB1	In	Interrupt request signal input from Slave Music LSI.
11	PB2	Out	Master Music LSI chip select signal output.
12	PB3	Out	Slave Music LSI chip select signal output.
13	PB4	Out	Write enable signal for Music LSIs.
14	PB5	Out	ID (Interrupt Disable) signal output. When Sub CPU is busy, it sends ID signal to Music LSIs so as not to be interrupted.
15	PB6 (LDC)	Out	Stays HIGH level for approximately 830 milliseconds after power switch is turned on in order to avoid mis-lighting of LEDs and shock noise on power UP.
17	PC0 (L11)	Out	LED drive signal output.
18	PC1 (SYC)	In	Synchronous signal from Main CPU.
19	PC2 (CONT)	In/Out	Control signal between Main and Sub CPUs.
20	PC3 ($\overline{INT2}$)	In	Interrupt signal from Music LSIs.
22~24	PC5 (L8) ~ PC7 (L10)	Out	LED drive signals output.
26	INT1	In	Interrupt signal from Main CPU.
28	\overline{RESET}	In	Reset signal input. The terminal receives a LOW level pulse at power ON. CPU internal circuits are initialized then.
31	X1	In	15MHz clock pulse input.
32	Vss		Ground (0V) source.
44	\overline{RD}	Out	Read signal output. Drops to LOW when Sub CPU reads data from peripheral devices.
45	\overline{WR}	Out	Write signal output. Drops to LOW when Sub CPU writes data into peripheral devices.
46	ALE	Out	Address latch enable signal output. Data signals D0~D7 become address signals AS0~AS7 when the terminal rises to HIGH.

Pin No.	Terminal Name	In/Out	Function
47~64	PF0 (AS8) ~ PF7 (AS15)	Out	Upper address signals (AS8 ~ AS15).
55~62	PD0 (DS0) ~ PD7 (DS7)	In/Out	Data signals (DS0 ~ DS7).
63, 64	VDD, Vcc		+5V power source.

Data Read and Write Timing Chart

Data Read

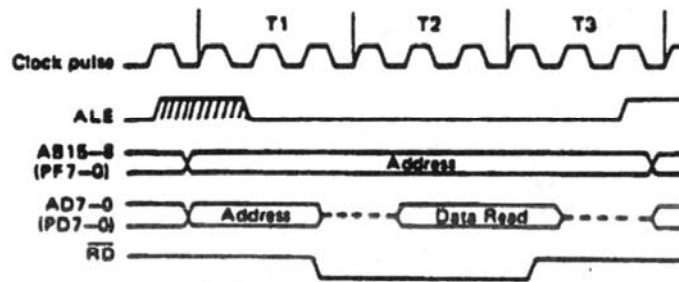

Data Write

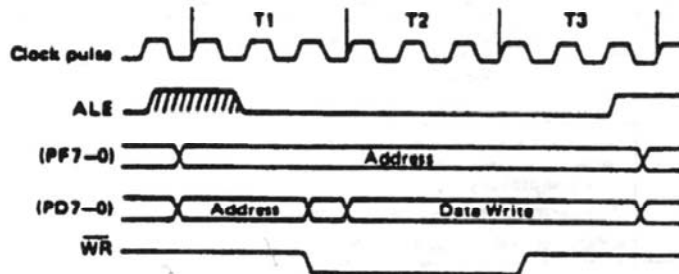

8. MAIN RAM & ROM ACCESSES

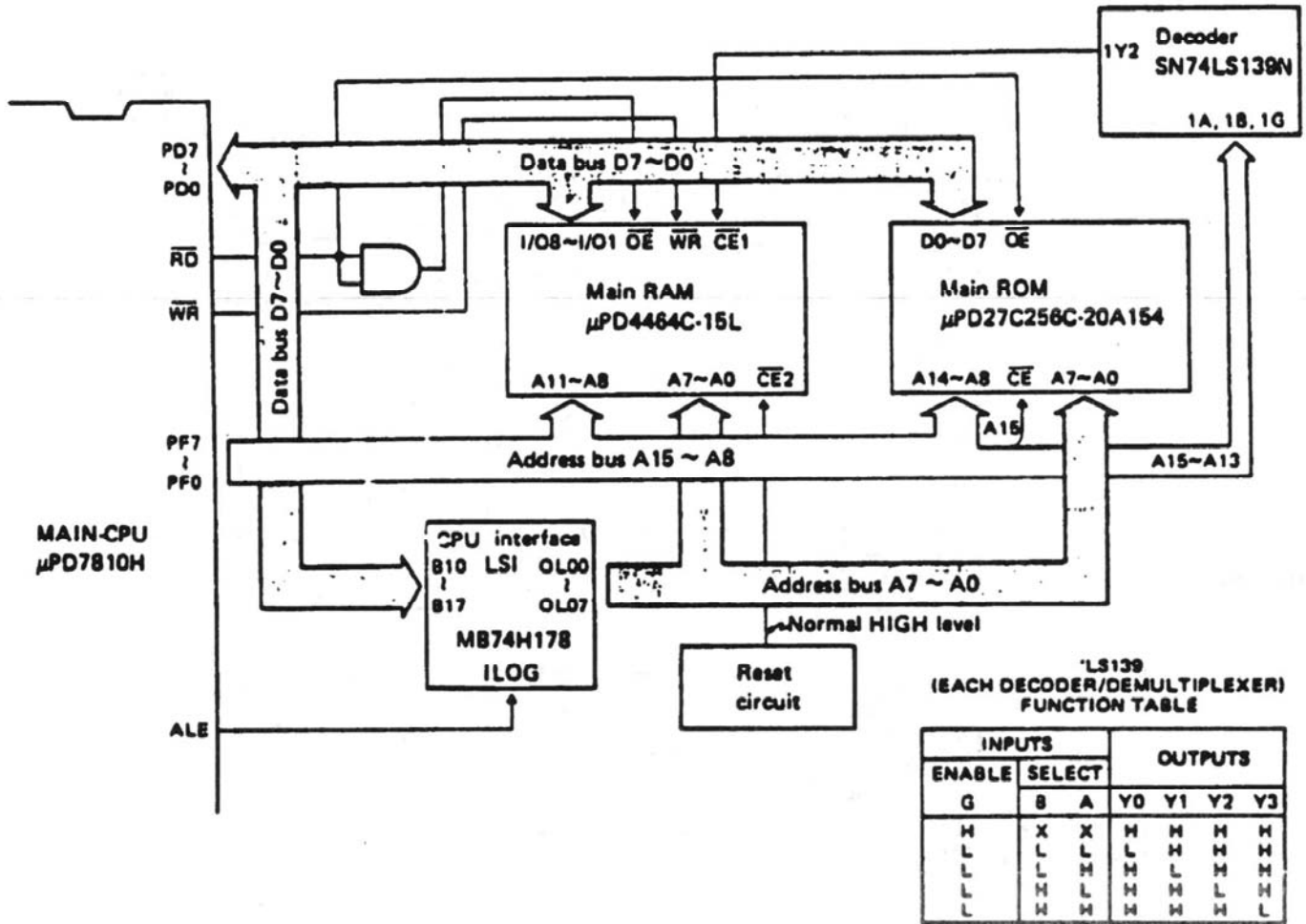

H=high level, L=low level, X=irrelevant

8K byte of Main RAM is the data area as written on page 17.

The RAM is backed up by +VBR (3V) of lithium battery.

The capacity of Main ROM is 32K byte and contains program for the system execution.

Lower address bus (A0 ~ A7) is provided from CPU interface LSI (MB74H178).

When signal ALE from Main CPU rises to HIGH, data bus (D0 ~ D7) becomes address bus (A0 ~ A7) in CPU interface LSI (MB74H178). Upper address bus A8 ~ A15 is directly supplied from Main CPU.

Chip select signals are from signals A13 ~ A15.

Chip selection	A13	A14	A15	WR	RD
Main RAM	LOW	LOW	HIGH	H or L	HIGH
Main ROM	-	-	LOW	-	LOW

9. SUB RAMs & ROM ACCESSES

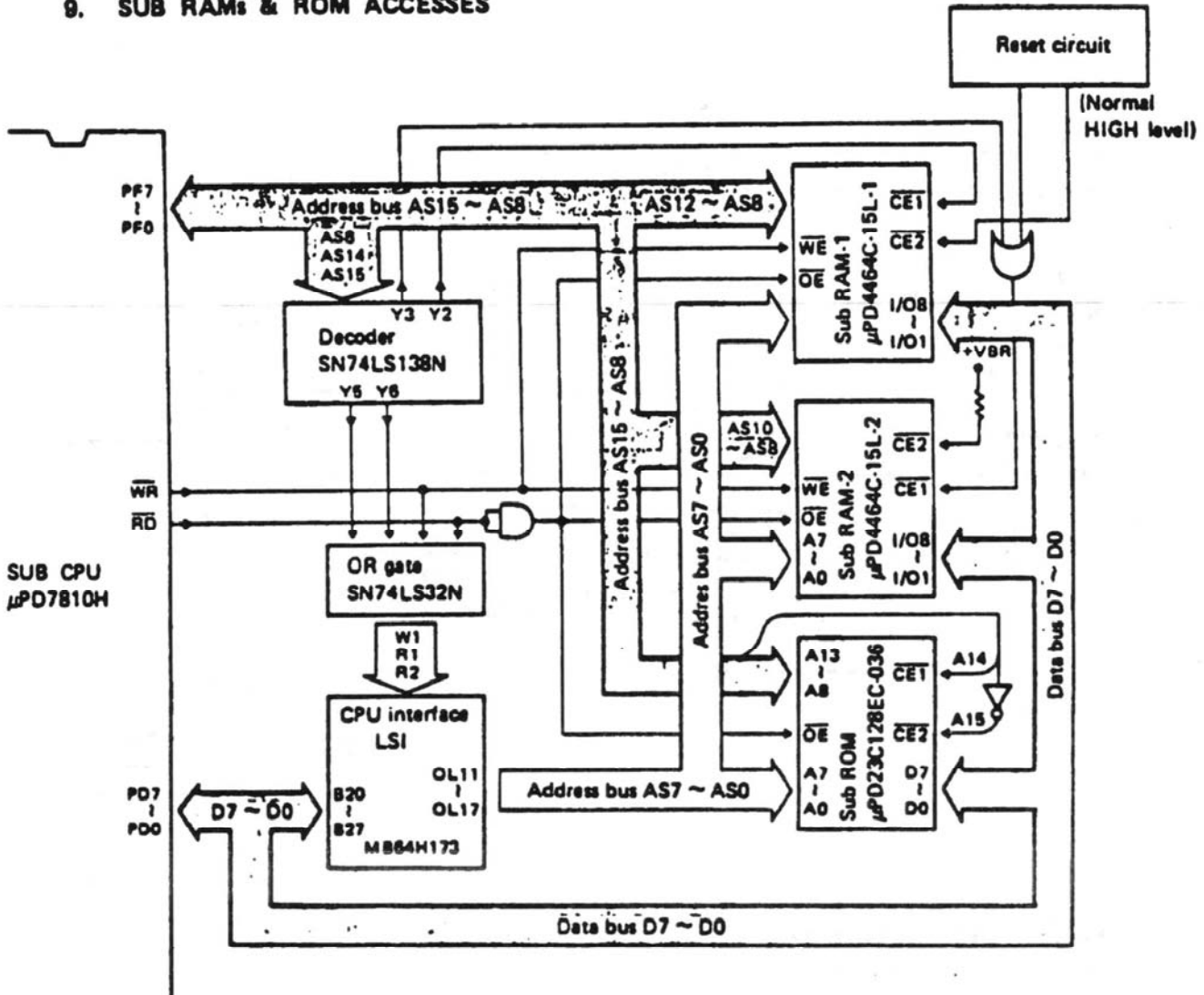

μPD4464C-15L is an 8K byte RAM while μPD23C128EC is a 16K byte ROM.

Refer to page 17 for the functions of each device.

In the same procedures as for Main CPU, lower address bus (AS0 ~ AS7) is generated from data bus (DS0 ~ DS7) in CPU Interface LSI (MB64H173) when signal ALE is HIGH. Upper address bus (AS8 ~ AS15) are provided from Sub CPU directly.

Chip select signals are generated from signals AS8, AS14 and AS15.

Chip selection	AS8	AS14	AS15	WR	RD
RAM-1	LOW	HIGH	LOW	L or H	HIGH
RAM-2	HIGH	HIGH	LOW	L or H	HIGH
ROM	-	LOW	HIGH	-	LOW

LS138
FUNCTION TABLE

ENABLE		INPUTS			OUTPUTS							
G1	G2*	C	B	A	Y0	Y1	Y2	Y3	Y4	Y5	Y6	Y7
L	X	X	X	X	H	H	H	H	H	H	H	H
L	X	X	X	L	L	L	L	L	L	L	L	L
L	X	X	L	X	H	L	H	H	H	H	H	H
L	X	X	L	L	H	L	L	H	H	H	H	H
L	X	L	X	X	H	H	H	L	H	H	H	H
L	X	L	L	X	H	H	H	L	L	H	H	H
L	X	L	L	L	H	H	H	L	L	L	H	H
L	X	L	L	L	H	H	H	L	L	L	L	H
L	X	L	L	L	H	H	H	L	L	L	L	L

*G2 = G2A + G2B
H = high level, L = low level, X = irrelevant

10. CPU INTERFACE LSI (MB84H173)

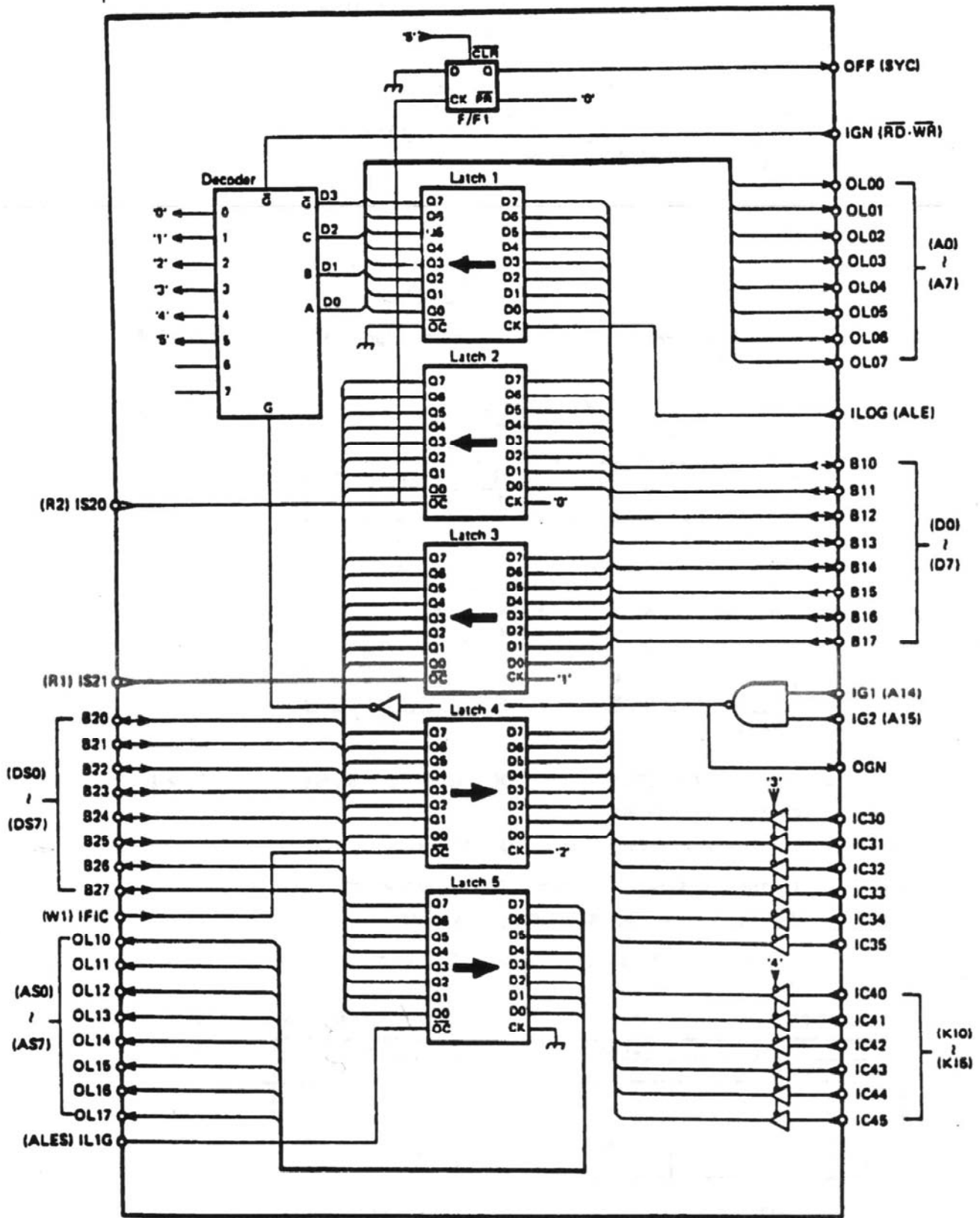

Internal block diagram of MB84H173

10-1. Function of Each Block

F/F 1 - Set by the clock pulse '0' and signal R2 from SUB CPU, and generates signal SYC which synchronizes MAIN and SUB CPUs.

FUNCTION TABLE

INPUT				OUTPUT	
PRESET	CLEAR	CLOCK	D	Q	\bar{Q}
L	H	X	X	H	L
H	L	X	X	L	H
L	L	X	X	H [*]	H [*]
H	H	↑	H	H	L
H	H	↑	L	L	H
H	H	L	X	Q ₀	\bar{Q}_0

Decoder 1 - Generates clock pulses for the latches from signals A0 ~ A3, A14, A15, \overline{PD} and \overline{WR} .

FUNCTION TABLE

ENABLE INPUT		SELECT INPUT			OUTPUT							
G1	\bar{G}_2^*	C	B	A	Y0	Y1	Y2	Y3	Y4	Y5	Y6	Y7
X	H	X	X	X	H	H	H	H	H	H	H	H
L	X	X	X	X	H	H	H	H	H	H	H	H
H	L	L	L	L	L	H	H	H	H	H	H	H
H	L	L	L	H	H	L	H	H	H	H	H	H
H	L	L	H	L	H	H	L	H	H	H	H	H
H	L	L	H	H	H	H	H	L	H	H	H	H
H	L	H	L	L	H	H	H	H	L	H	H	H
H	L	H	L	H	H	H	H	H	H	L	H	H
H	L	H	H	L	H	H	H	H	H	H	L	H
H	L	H	H	H	H	H	H	H	H	H	H	L

* $\bar{G}_2 = \bar{G}_2A + \bar{G}_2B$

Latch 1 - Converts MAIN CPU's data bus (D0 ~ D7) into address bus A0 ~ A7, and generates clock pulses '0' ~ '5'.

Latch 2 - For data transfer from MAIN CPU to SUB CPU.

Latch 3 - Transfers data from pitch bender and modulator wheel to SUB CPU.

Latch 4 - For data transfer from SUB CPU to MAIN CPU.

Latch 5 - Converts SUB CPU's data bus (DS0 ~ DS7) into address bus AS0 ~ AS7.

FUNCTION TABLE (EACH LATCH)

INPUT			OUTPUT
\bar{OC}	ENABLE	C	D
L	H	H	H
L	H	L	L
L	L	X	Q ₀
H	X	X	Z

Latch 1 and 5

FUNCTION TABLE (EACH FLIP-FLOP)

INPUT			OUTPUT
\bar{OC}	CLK	D	Q
L	↑	H	H
L	↑	L	L
-	L	X	Q ₀
↑	X	X	Z

Latch 2 ~ 4

10-2. Data Transfer Procedures

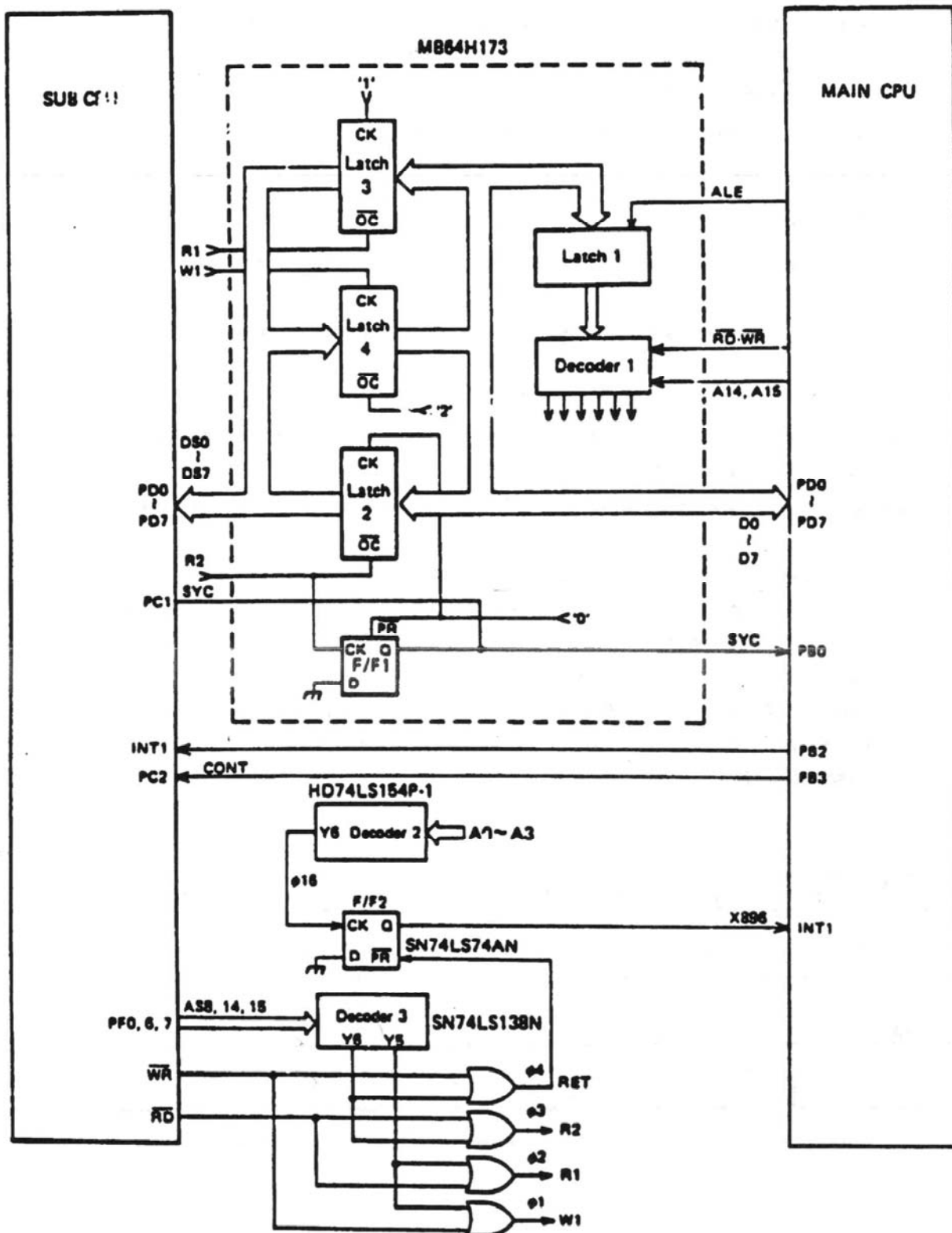

(1) Pitch Bender & Modulator \Rightarrow SUB CPU.

- ① Voltage level from the pitch bender or the modulator is converted into digital data in the CPU's built-in ADC (Analog to Digital Converter) and output from data bus (D0 ~ D7).
- ② The data is entered into CPU Interface LSI.
- ③ Sending signal R1, SUB CPU sets Latch 3 and reads data periodically.

(2) MAIN CPU \Rightarrow SUB CPU.

- ① Via Latch 1 and Decoder 1, MAIN CPU drops clock pulse '0' to LOW level. By clock pulse '0', F/F 1 is preset to rise signal SYC.
- ② MAIN CPU puts data on data bus D0 ~ D7, and at the same time, clock pulse '0' rises to HIGH level. At the rising edge of clock pulse '0', data from MAIN CPU is set in Latch 2.
- ③ MAIN CPU interrupts SUB CPU from terminal PB2, and simultaneously generates signal CONT from terminal PB3.
- ④ Generating signal R2 from Decoder 3, SUB CPU reads the data from Latch 2 via data bus DS0 ~ DS7.
- ⑤ SUB CPU sends signal ACK to MAIN CPU via Decoder 3 and F/F 2. Upon receipt of signal ACK, MAIN CPU confirms that SUB CPU has received the data and generates signal $\phi 1B$ in Decoder 2.
- ⑥ When all the data have sent to SUB CPU by repeating the above procedures ① ~ ⑤, MAIN CPU drops signal CONT to LOW.
- ⑦ Confirming that both CONT and SYC are LOW, SUB CPU determines that all the data have been received.

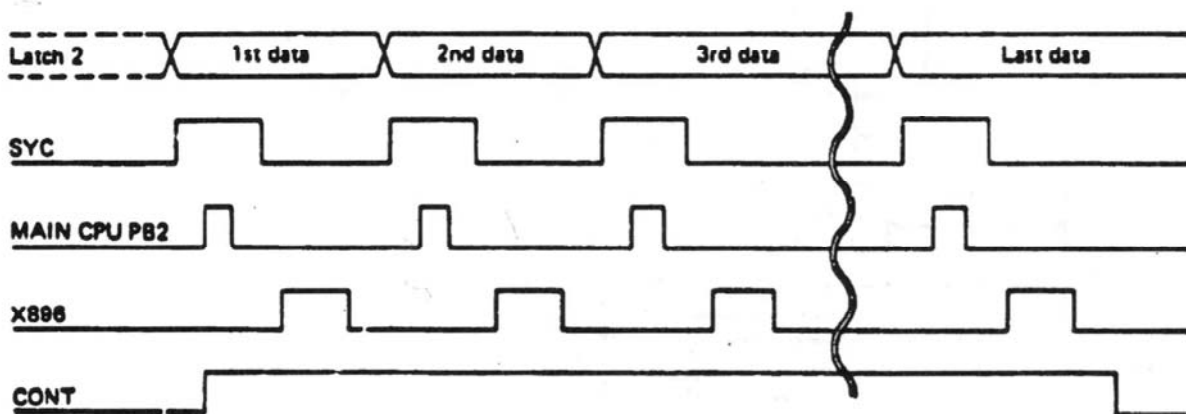

(3) SUB CPU → MAIN CPU.

- ① In the same procedures as stated in the item (2), MAIN CPU sends "Request Command" that inquires SUB CPU to transmit data.
- ② SUB CPU puts data on data bus DS0 ~ DS7 and sets the data in Latch 4 by signal W1. SUB CPU then presets F/F 2 by pulse $\phi 4$, causing signal X896 to be entered in MAIN CPU.
- ③ Acknowledging that data is set in Latch 4 by signal X896, MAIN CPU generates clock pulse '2', causing data from SUB CPU to be put on MAIN CPU data bus D0 ~ D7.
- ④ After receiving data, MAIN CPU sends SUB CPU an interrupt signal from terminal PB2, and by interrupt signal, SUB CPU confirms that the data is received by MAIN CPU.
- ⑤ Repeating the above procedures ② ~ ④, SUB CPU sends the next data to MAIN CPU.

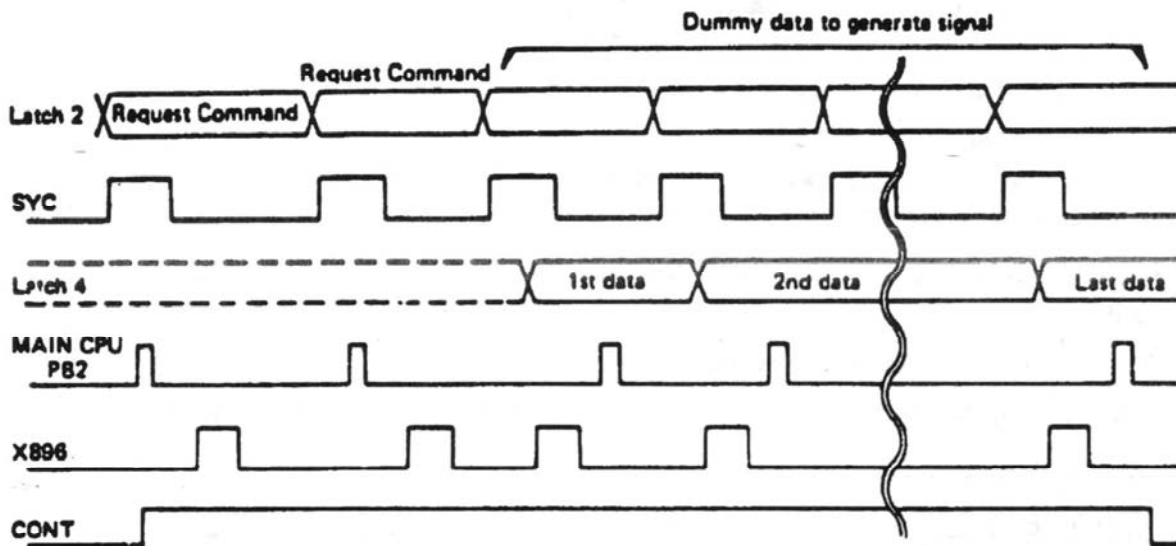

10-3. Switch Matrix

	KI 5	KI 4	KI 3	KI 2	KI 1	KI 0
KC 0	MIDI	SOLO	OPERATION MEMORY	KEY SPLIT	STONE MIX	NORMAL
KC 1	CARTRIDGE	EXCHANGE	MASTER TUNE	KEY TRANPOSE	GLIDE ON/OFF	PORTAMENTO ON/OFF
KC 2	BANK F	BANK E	BANK D	BANK C	BANK B	BANK A
KC 3	BANK H	BANK G	MEMORY 8	MEMORY 7	MEMORY 6	MEMORY 5
KC 4	MEMORY 4	MEMORY 3	MEMORY 2	MEMORY 1	YES →	NO ←
KC 5	VALUE ▲ LOAD	VALUE ▼ SAVE	ENV. POINT END	ENV. POINT SUSTAIN	PAGE UP	PAGE DOWN
KC 6	CARTRIDGE SAVE/LOAD	NAME	PORTAMENTO	GLIDE	BEND RANGE	WHEEL/ AFTER TOUCH
KC 7	NOISE	RING	LINE SELECT	VIBRATO	OCTAVE	INITIALIZE
KC 8	DCA 1 ENV	DCA 1 KEY FOLLOW	DCW 1 ENV	DCW 1 KEY FOLLOW	DCO 1 ENV	DCO 1 WAVE FORM
KC 9	DCA 2 ENV	DCA 2 KEY FOLLOW	DCW 2 ENV	DCW 2 KEY FOLLOW	DCO 1 ENV	DCO 1 WAVE FORM
KC10	DETUNE	PARAMETER COPY	DCA 2 LEVEL	DCA 1 LEVEL	DCA 2 VELOCITY	DCA 1 VELOCITY
KC11	SUSTAIN PEDAL	PROTECT ON/OFF	MODULATION ON/OFF	WRITE	COMPARE/ RECALL	MIDI ON/OFF
KC12						PACK DETECTION

11. KEYBOARD

CZ-1 varies the sound volume in accordance with the key touch speed and depression strength.

11-1. Key Touch Speed Detection

Each key has two key contact switches S1 and S2.

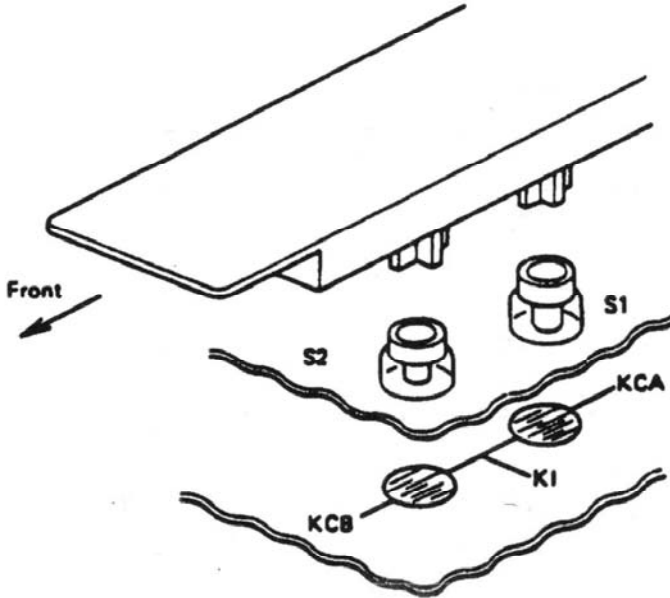

Fig. 11-1

When a key is hit, S1 turns on first, then S2.

The interval time between turning on of S1 and S2 varies according to the touch speed of the key.

LSI MSM 6200 detects the time interval and determines the key touch speed.

Some RC (resistor and capacitor) integrating circuits are connected to the MSM6200 and when switch S1 turns on, the RC circuit starts to discharge. The discharging stops when S2 turns on.

The MSM 6200 also contains an ADC (Analog to Digital Converter) and changes the voltage V_c of the RC circuits into a 5-bit digital signal which is sent to the CPU as key entry and hitting speed data.

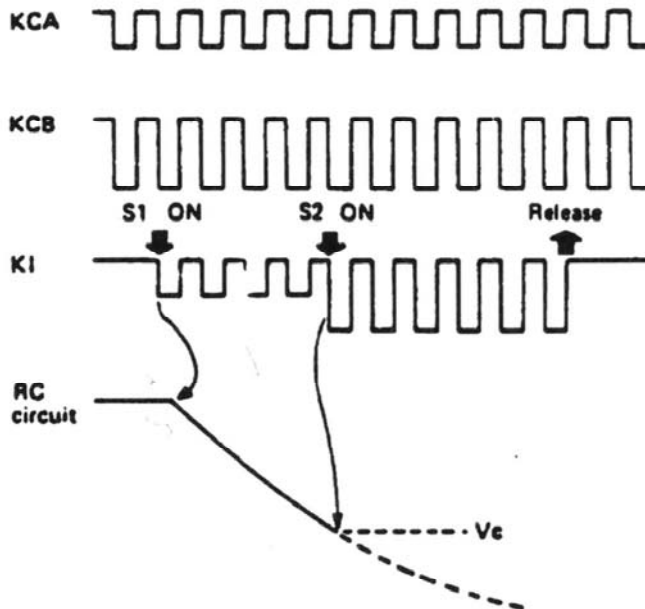
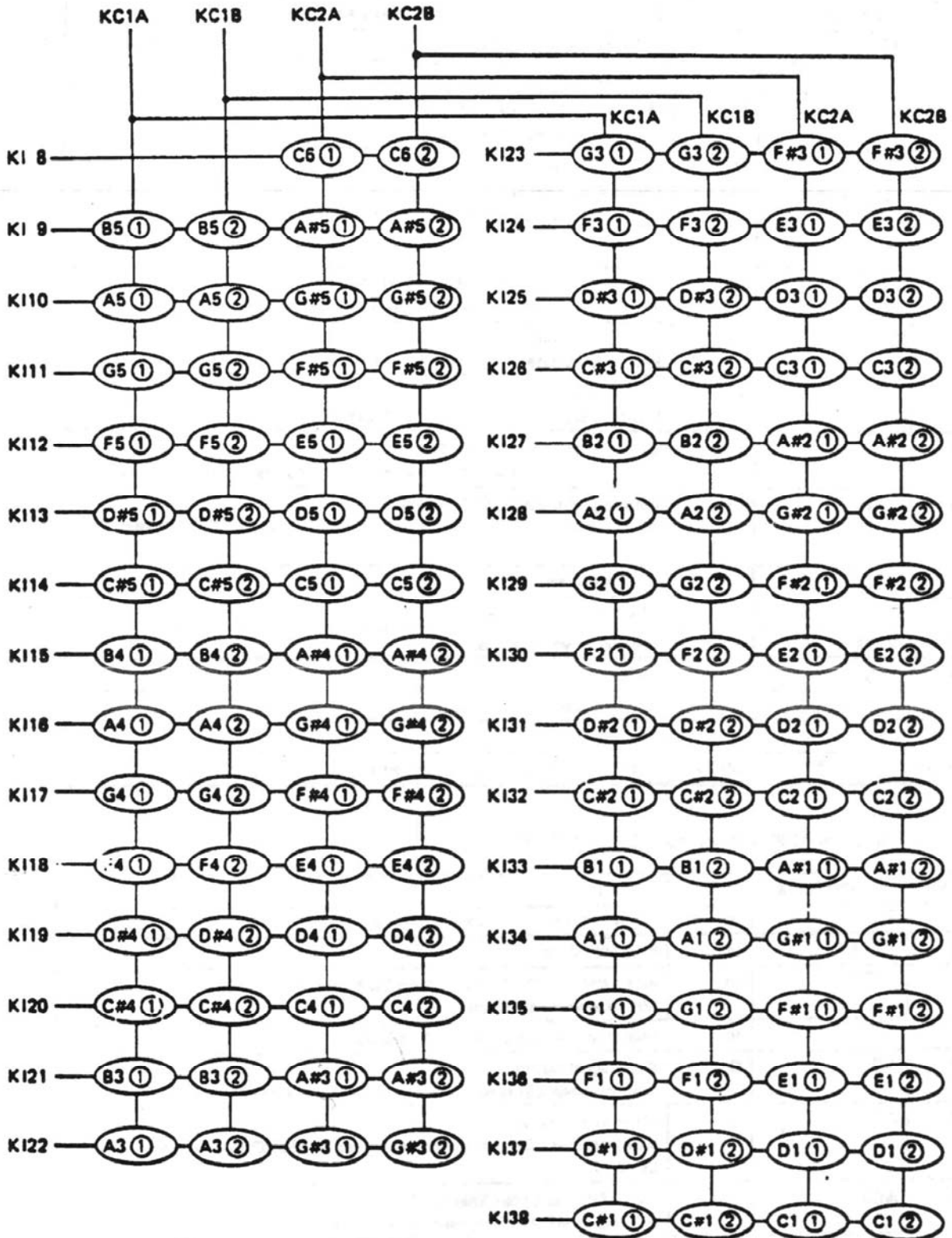

Fig. 11-2

11-2. Key Matrix



11-3. Pin Functions of Key Touch Control LSI (MSM6200)

Pin No.	Terminal Name	In/Out	Function
1 ~ 8	IR6 ~ IC8	In/Out	External RC discharging circuit inputs and outputs.
10	REF		Reference voltage (+5V).
11	AG		Analog ground.
20	O1	Out	Interrupt request signal output. When LOW, MSM6200 interrupts the CPU.
25~28 29~32	O2 ~ O5 IO1 ~ IO4	Out In/Out	Upper 4-bit data bus. Lower 4-bit data bus. O2 O3 O4 O5 IO1 IO2 IO3 IO4 MSB LSB
34	I 2	In	ALE (Address Latch Enable) signal input. When HIGH, address in MSM6200 is assigned.
35	I 3	In	WR signal input. When LOW, data or address can be written in MSM6200.
36	I 4	In	RD signal input. When LOW, CPU reads data from MSM6200.
37	I 5	In	CS (chip select) signal input. When LOW, communications between the CPU and MSM6200 is possible.
39	I 10	In	Reset signal input. LOW: Active. At power on, receives a reset signal to initialize MSM6200's internal circuits.
40	VDD		+5 volt source.
43	PGI	In	Clock pulse (2.47 MHz) input.
45	VSS2		Ground (0 volt) source.
46	VSS1		+2.25 volt source.
47~50	KC2B ~ KC1A	Out	Key common signal outputs.
58~68	K8 ~ K38	In	Key input terminals.
91~100	IR1 ~ IC5	In/Out	External CR circuits inputs and outputs.

11-4. Pin Functions of Key Interface LSI (μ PD8049HC)

Pin No.	Terminal Name	In/Out	Function
1	T0	In	Clock pulse input for data read/write.
2	XTAL1	In	8.96 MH clock pulse input.
4	RESET	In	At power ON, the terminal stays LOW level for a while in order to initialize internal circuits.
8	INT	In	Interrupt signal input from MSM6200.
8	RD	Out	Read signal output. Key interface LSI reads data from MSM6200 when terminal is LOW.
10	WR	Out	Write signal output. Key interface LSI writes data or address in MSM6200 when terminal is LOW.
11	ALE	Out	ALE (Address Latch Enable) signal output. Address in MSM6200 is assigned when HIGH level.

Pin No.	Terminal Name	In/Out	Function
12~19	DB0 ~ DB7	In/Out	Data bus (D0 ~ D7) between MSM6200.
20	Vss		Ground (0V) source.
26	VDD		+5V source.
27~34	P10 ~ P17	Out	Data bus (D0 ~ D7) between Main CPU.
36	P25 (CNT49)	In	Control signal input from CPU.
37	P26 (INT49)	Out	Interrupt signal output to CPU.
38	P27 (WR49)	Out	Timing pulse output for data read/write.
39	T1 (TST)	In	Test signal input. Key interface LSI does selfcheck of internal RAM/ROM at LOW.
40	VCC		+5V source.

11-5. Key Touch Data Communication

(1) Block Diagram

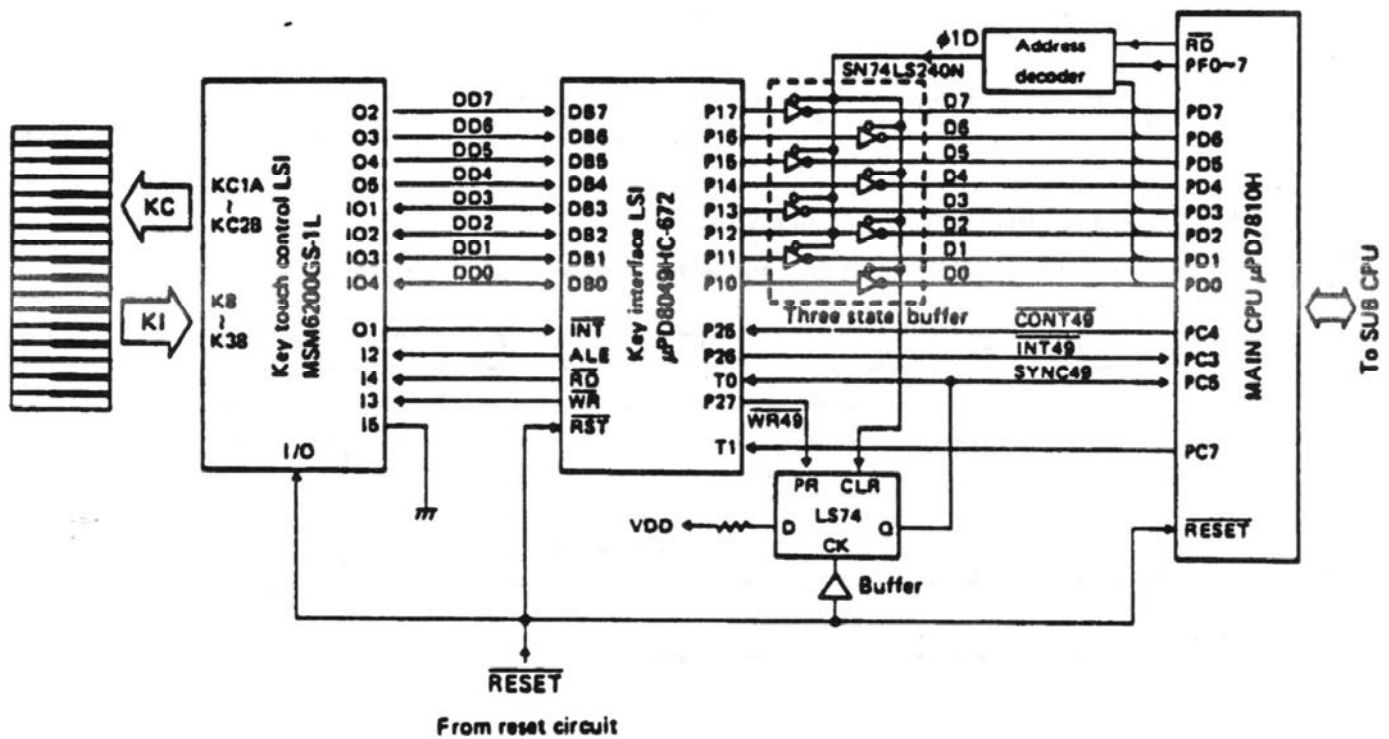

Key touch control LSI fetches the data of key entry and key touch speed from keyboard, then the data are transmitted to Main CPU via Key interface LSI which is a buffer.

The Key interface LSI quicken the data communication between the Key touch control LSI and the CPU.

(2) Timing chart from MSM6200 to μ PD8049HC

For sending mainly key entry and initial touch data.

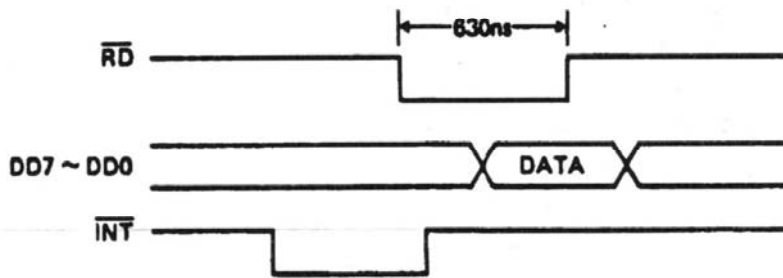

(3) Timing chart from μ PD8049HC to MSM6200

For sending mainly request command of key entry and key touch speed data.

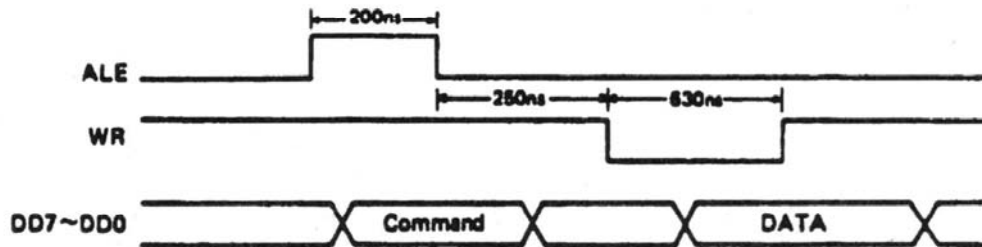

(4) Timing chart from μ PD8049HC to MSM6200

For transmitting mainly key entry and key touch speed data in this process.

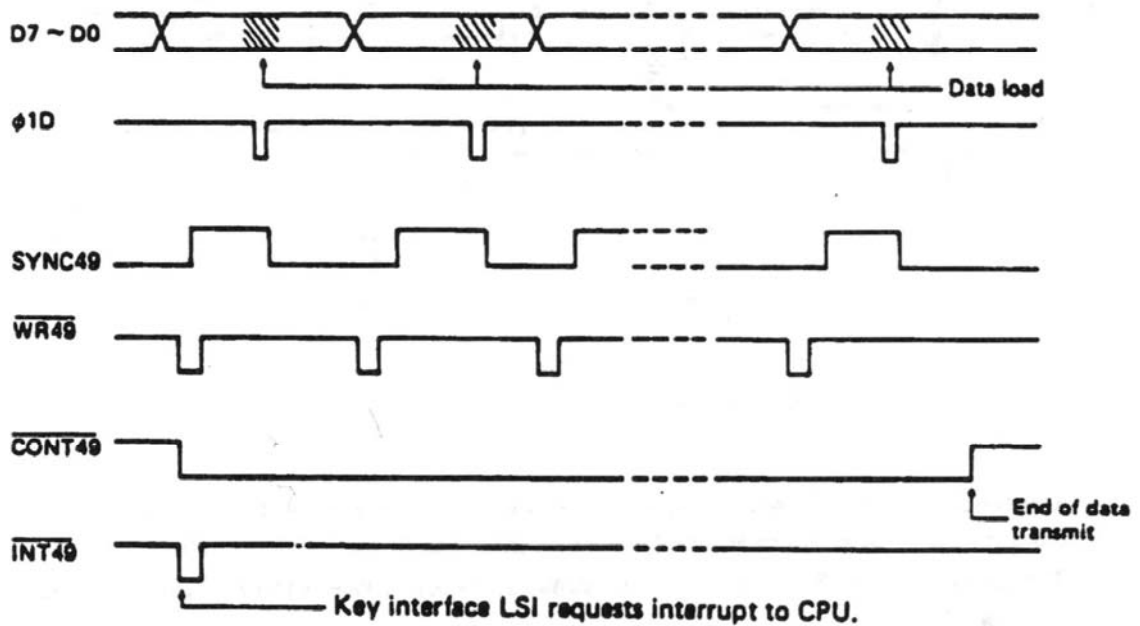

11-8. After Touch Control Circuit

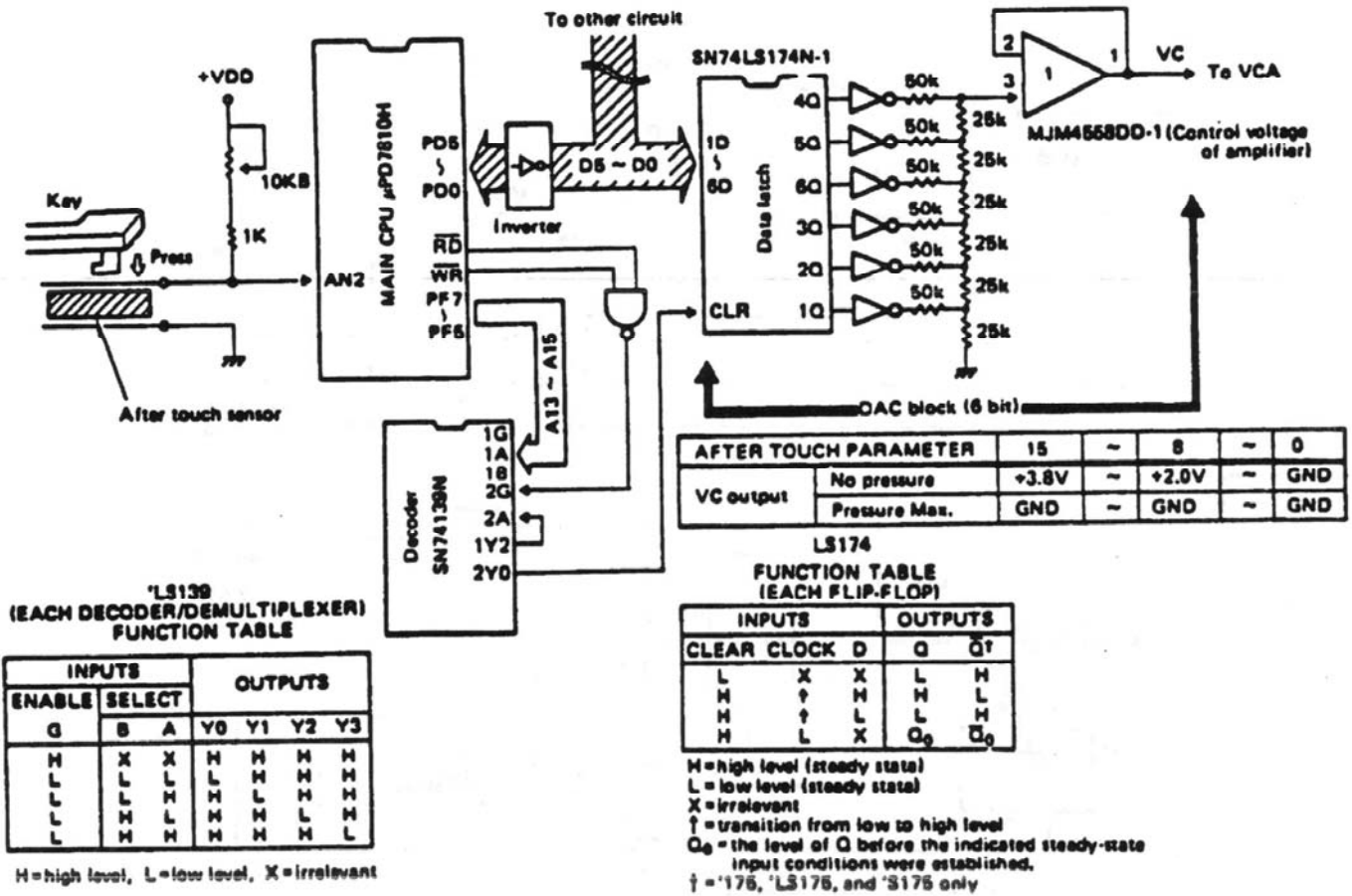

- (1) When the after touch sensor is pressed harder, its resistance becomes lower dropping the voltage level of terminal AN2.
- (2) Main CPU converts analog signal into digital data in the internal ADC (Analog to Digital Converter), then output the data to DAC (Digital to Analog Converter) block.
- (3) These data are converted to analog signal by DAC block.
- (4) The output voltage VC is input to VCA (M5241L) on PCB AS1M, to vary the amplitude of the VCA.

Note: Construction of after touch sensor.

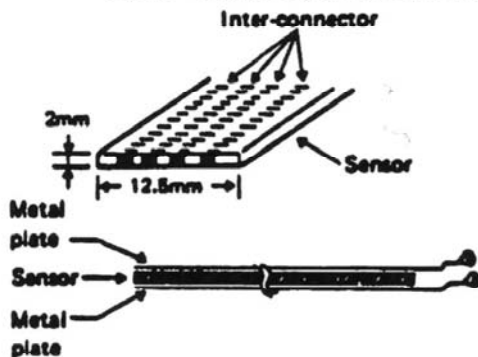

After touch sensor is a sheet of silicon rubber in which carbon particles are inlaid.

While no force is applied, the resistance between the both sides is infinity. However, when it is pressed hard, the density of the carbon becomes high causing its resistance to be as small as 10 ~ 30 ohms.

The silicon rubber is put between two thin metal plates.

12. DATA CLOCK PULSE GENERATOR

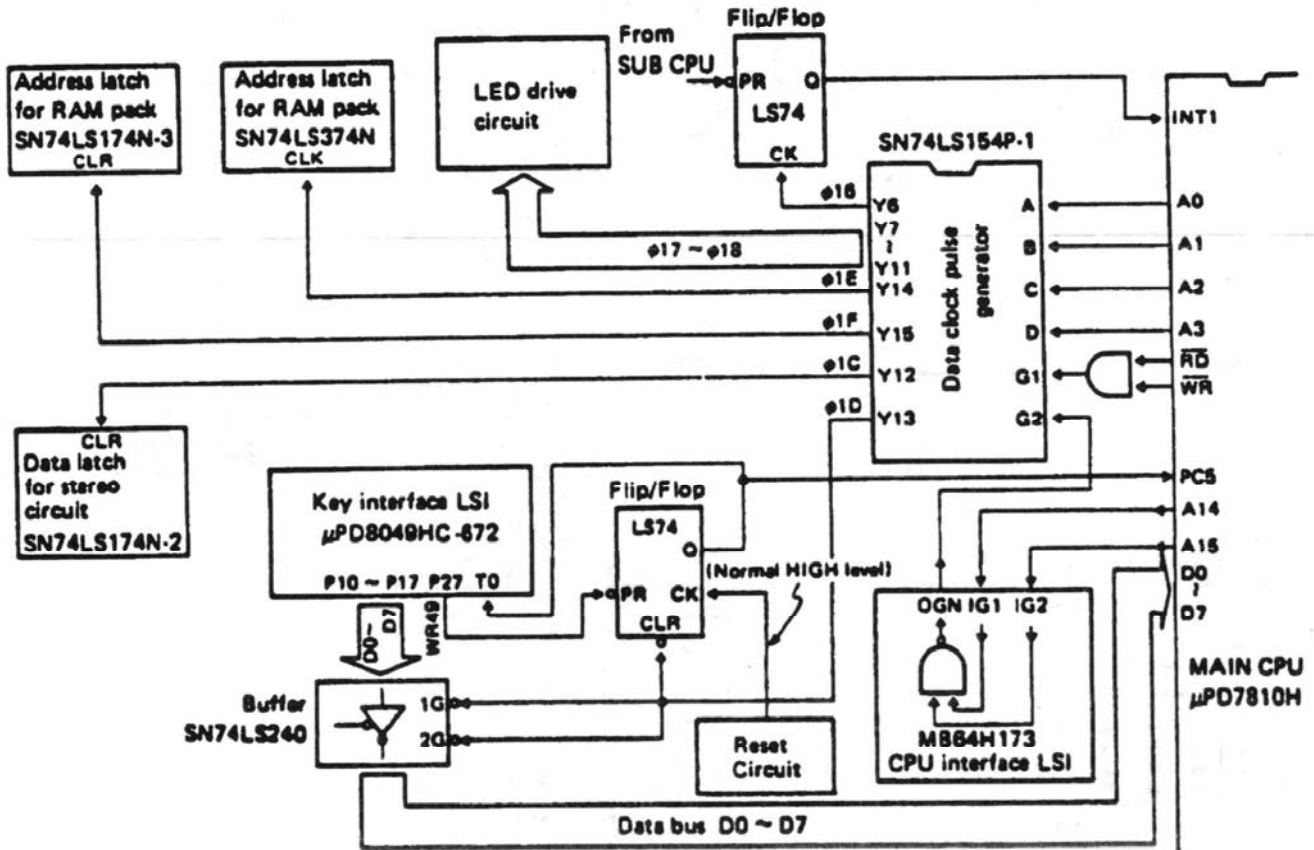

Terminal	Clock	Function
Y6	φ18	Clock pulse for interrupt from Sub CPU to Main CPU.
Y7~Y11	φ17~φ18	Clock pulse for LED drive circuit.
Y12	φ1C	Clock pulse of control signal for stereo circuit.
Y13	φ1D	Enable signal of buffer (SN74LS240N) and reset pulse of Flip/Flop (SN74LS74) for key data transmission.
Y14, Y15	φ1E, φ1F	ALE (Address Latch Enable) signal for RAM pack.

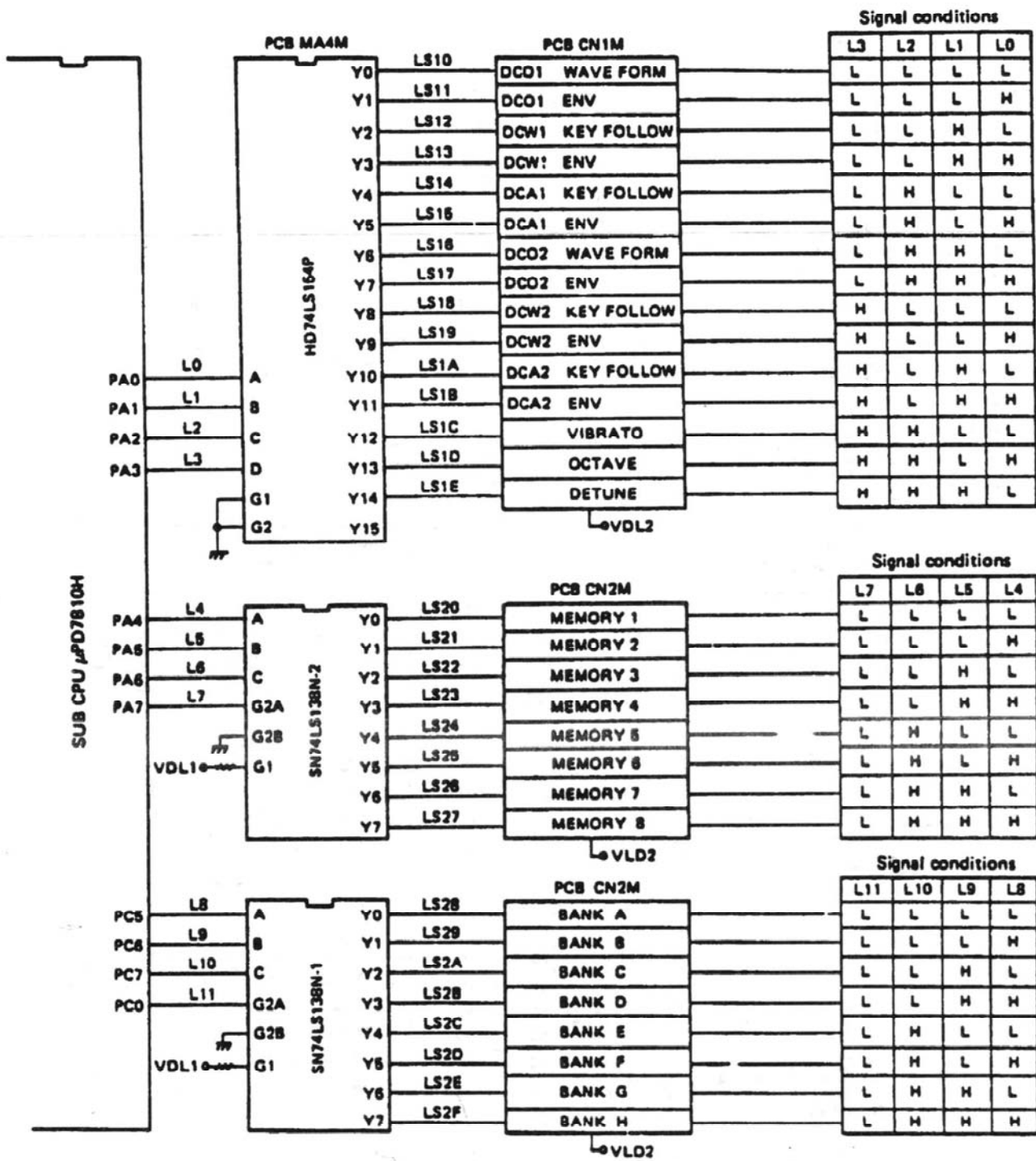

These LEDs are controlled by Sub CPU.
 For example, when Sub CPU wishes to light the "BANK-A" LED, it drops all the signals L8 ~ L11. Y0 output of Decoder 5 drops to LOW, causing the LED to be lit.

14. ANALOG CIRCUIT BLOCK DIAGRAM

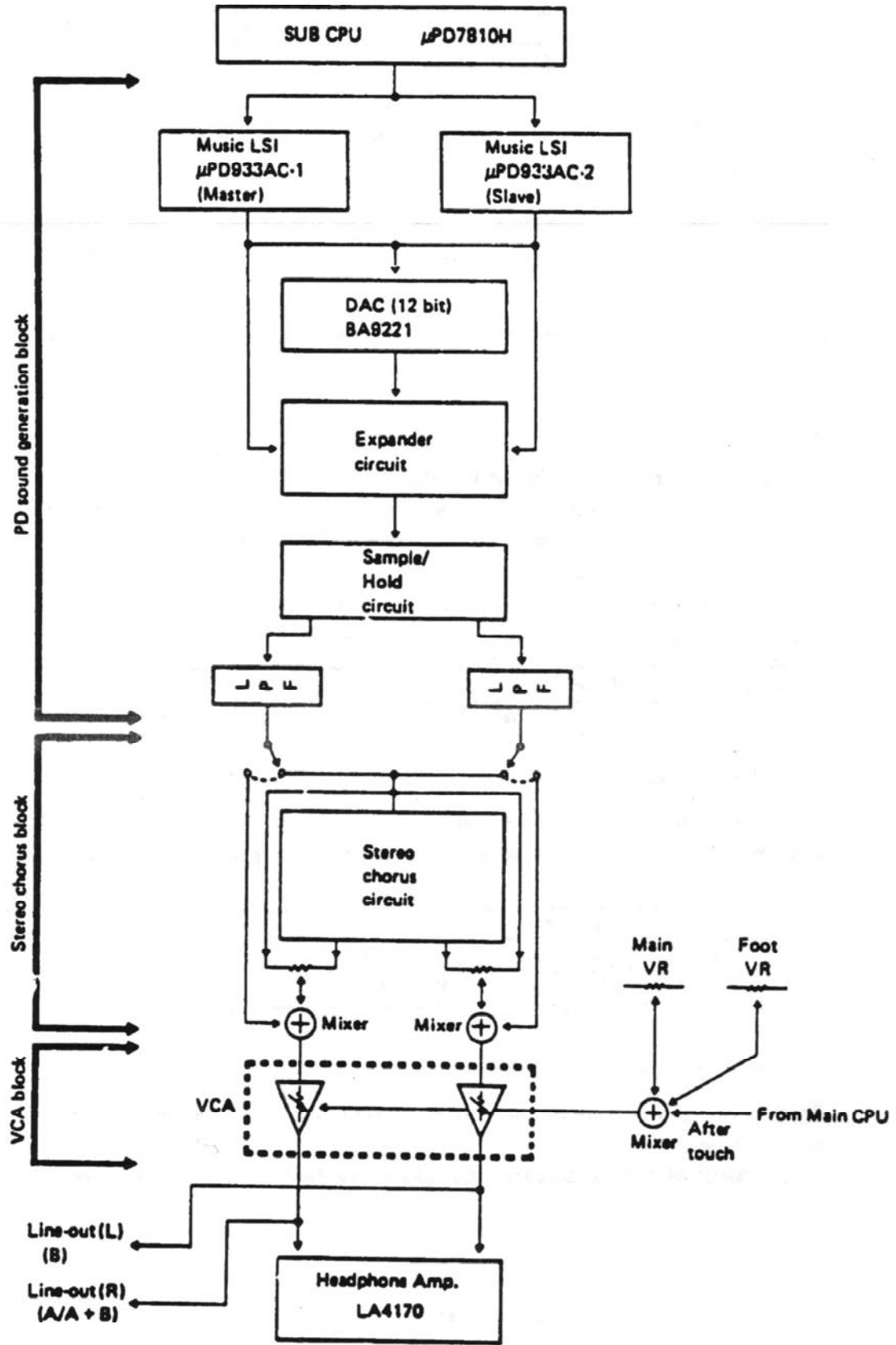

(1) PD (Phase Distortion) Sound Block

Music LSI Two LSIs generate digital PD sound signals as show below.

Mode	NORMAL	TONE MIX	KEY SPLIT
μ PD833AC-1 (Master)	Mix	TONE 1	LOW
μ PD833AC-2 (Slave)		TONE 2	UPPER

DAC (Digital to Mixes the two different digital signals and converts into an Analog Converter) analog signal.

Expander Circuit Music LSIs' outputs are contracted to obtain a wide dynamic range of amplitude. Expander circuit reforms it into a proper waveform.

Sample/Hold Circuit Removes a high frequency noise called as glitch contained in the DAC output. Also separates the master and slave waveforms.

(2) After Touch Block

After touch effect gives variation of amplitude and modulation to the output sound. After touch sensor under the keyboard varies its resistance from infinity to approximately 10ohm by means of pressure strength. The change of the resistance is input to Music LSIs or VAC circuit via main CPU. The CZ-1 is able to set the depth of the effects by parameter (0 ~ 15).

After touch effect	Flow of after touch signal
Modulation	Sensor \Rightarrow Main CPU \Rightarrow Music LSIs
Amplitude	Sensor \Rightarrow Main CPU \Rightarrow After touch control circuit \Rightarrow VCA circuit

(3) Stereo Chorus Block

Gives stereo effect to the output sound. ON/OFF of stereo effect is input by panel switch. The stereo chorus effect can be set individually even in Tone Mix or Key Split mode.

Ex.

Mode	Stereo effect ON/OFF
Tone mix	Tone 1: ON, Tone 2: OFF
Key split	LOW: OFF, UPPER: ON

(4) VCA (Voltage Controlled Amplifier)

Receives voltage which are converted from the resistance value of Main VR, Foot VR, or after touch sensor. In accordance with the voltage level, this block vary the amplitude of the sound.

15. MUSIC LSI: ACCESSES

CZ-1 employs two Music LSIs, Master LSI and Slave LSI, which are controlled by SUB CPU.

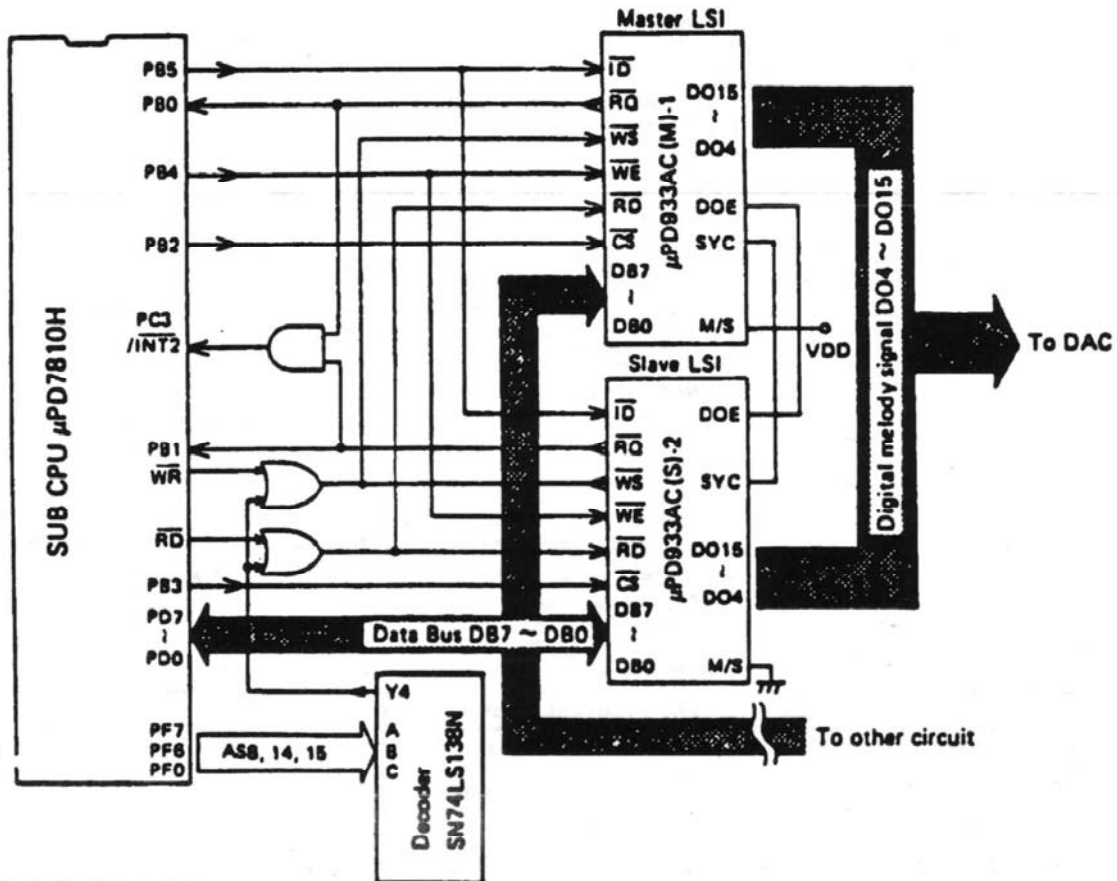

(1) SUB CPU \leftrightarrow Music LSI

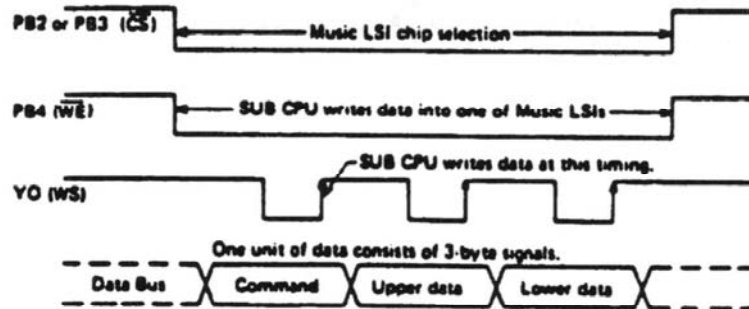

(2) Music LSI \rightarrow SUB CPU

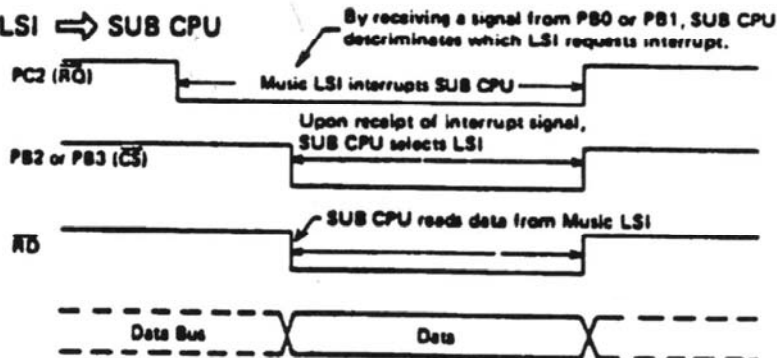

16. PIN FUNCTION OF MUSIC LSI (μ PD933AC)

Pin No.	Terminal Name	In/Out	Function
1	\overline{WE}	In	Write enable terminal. At LOW, the LSI receives data from SUB CPU.
2	\overline{WS}	In	Write strobe terminal. SUB CPU writes data into Music LSI at the rising edge of the signal.
3	\overline{RQ}	Out	Request signal terminal. At LOW.
4	\overline{ID}	In	Interrupt disable terminal. At LOW, the LSI receives interrupt mask signal.
6	$\overline{M/S}$	In	Master or Slave determination terminal. When LOW, the LSI becomes Slave LSI while it becomes Master LSI when the terminal is HIGH.
7	SYC	In/Out	Synchronous signal input/output terminal. The synchronous signal is sent from Master LSI to Slave LSI.
8	CLK	In	4.48 MHz clock pulse input.
10	GND		Ground (0V) source.
11	RST	In	Reset signal input. Normally the terminal stays LOW. At power ON, the terminal rises to HIGH level for a while and the internal circuits of the LSI are initialized.
12	DOE	In/Out	Data output enable terminal. At HIGH, digital sound signals are output from Master LSI while Slave LSI outputs sound signal at LOW level.
13	SH	Out	40 KHz sampling signal for Sample & Hold circuit.
15~17	DO1 ~ DO3	Out	Control signals for Expander circuit.
18~29	DO4 ~ DO15	Out	12-bit digital sound signals.
30	VDD		+5V power source.
31~38	DB7 ~ DB0	In/Out	8-bit data bus between Music LSIs and SUB CPU.
39	\overline{CS}	In	Chip select terminal. At LOW, the LSI is designated by SUB CPU.
40	\overline{RD}	In	Read data terminal. At LOW, the LSI sends data to SUB CPU.

17. DAC (Digital to Analog Converter) CIRCUIT

The two Music LSIs output different waveforms. When signal DOE is HIGH, Master LSI outputs a waveform while Slave LSI outputs a waveform at LOW level of DOE.

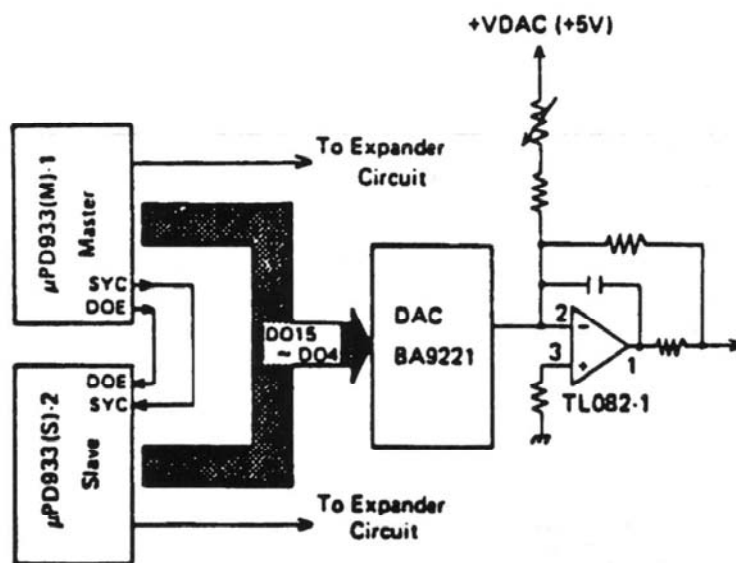

Note: As the following figure is an illustration for a principle of the time sharing, the actual waveforms differ.

Master/Slave LSI are digital signals, not analog ones.

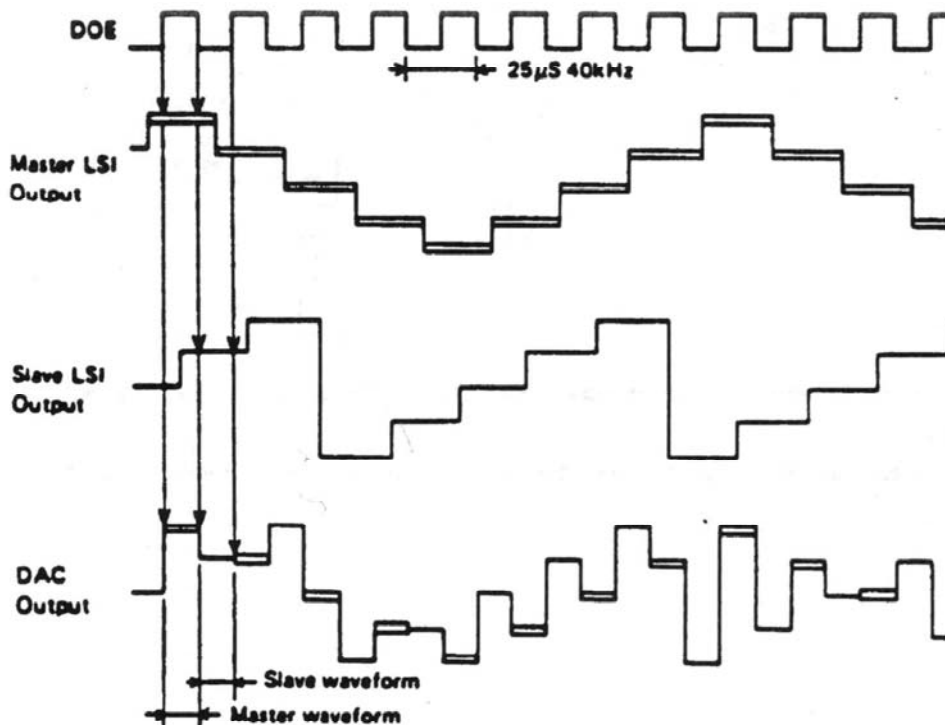

18. EXPANDER CIRCUIT

In order to extend the dynamic range of the melody signal, a part of DAC output waveform is contracted and expanded by Expander Circuit.

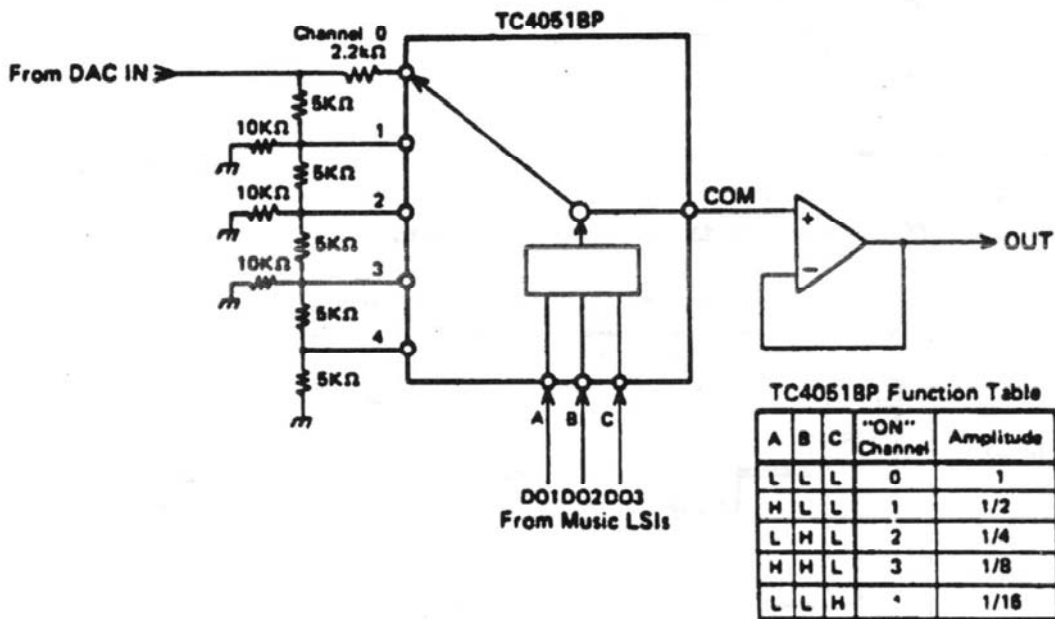
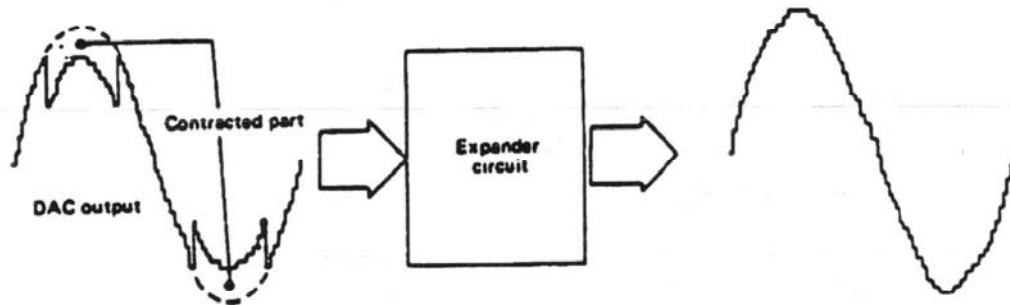

In accordance with the voltage levels of the signals DO1, DO2 and DO3, one of the input channels is turned on.

By the resistors connected to each channel, the amplitude of DAC output varies from 1 to 1/16.

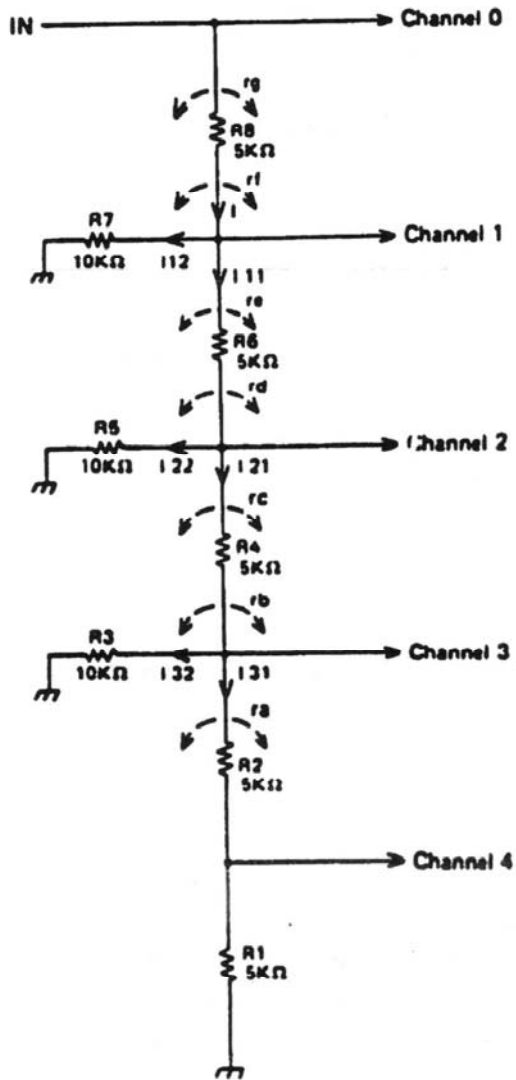

Combined resistances at each point are:

$$\begin{aligned}
 r_a &= R_1 (5K\Omega) + R_2 (5K\Omega) = 10K\Omega \\
 r_b &= \text{Parallel connected } r_a (10K\Omega) \text{ and } R_3 (10K\Omega) = 5K\Omega \\
 r_c &= r_b (5K\Omega) + R_4 (5K\Omega) = 10K\Omega \\
 r_d &= \text{Parallel connected } r_c (10K\Omega) \text{ and } R_5 (10K\Omega) = 5K\Omega \\
 r_e &= r_d (5K\Omega) + R_6 (5K\Omega) = 10K\Omega \\
 r_f &= \text{Parallel connected } r_e (10K\Omega) \text{ and } R_7 (10K\Omega) = 5K\Omega \\
 r_g &= r_f (5K\Omega) + R_8 (5K\Omega) = 10K\Omega
 \end{aligned}$$

Each current value is:

$$\begin{aligned}
 I &= I_{11} + I_{12} \\
 I_{11} &= I_{21} + I_{22} \\
 I_{21} &= I_{31} + I_{32}
 \end{aligned}$$

Namely, $I_{11} = I/2$

$$I_{21} = I_{11}/2 = I/4$$

$$I_{31} = I_{21}/2 = I/8$$

Voltage level at each channel is:

$$\text{Channel 0: } r_g \times I = 10K\Omega \times I$$

$$\text{Channel 1: } r_e \times I_{11} = 10K\Omega \times I/2$$

$$\text{Channel 2: } r_c \times I_{21} = 10K\Omega \times I/4$$

$$\text{Channel 3: } r_a \times I_{31} = 10K\Omega \times I/8$$

$$\text{Channel 4: } R_1 \times I_{31} = 5K\Omega \times I/8 = 10K \times I/16$$

If input voltage is E:

Channel 0 input voltage is E.

Channel 1 input voltage is E/2.

Channel 2 input voltage is E/4.

Channel 3 input voltage is E/8.

Channel 4 input voltage is E/16.

Thus, output of DAC is expanded in accordance with the voltage levels of signals DO1, DO2 and DO3.

19. SAMPLE & HOLD CIRCUIT

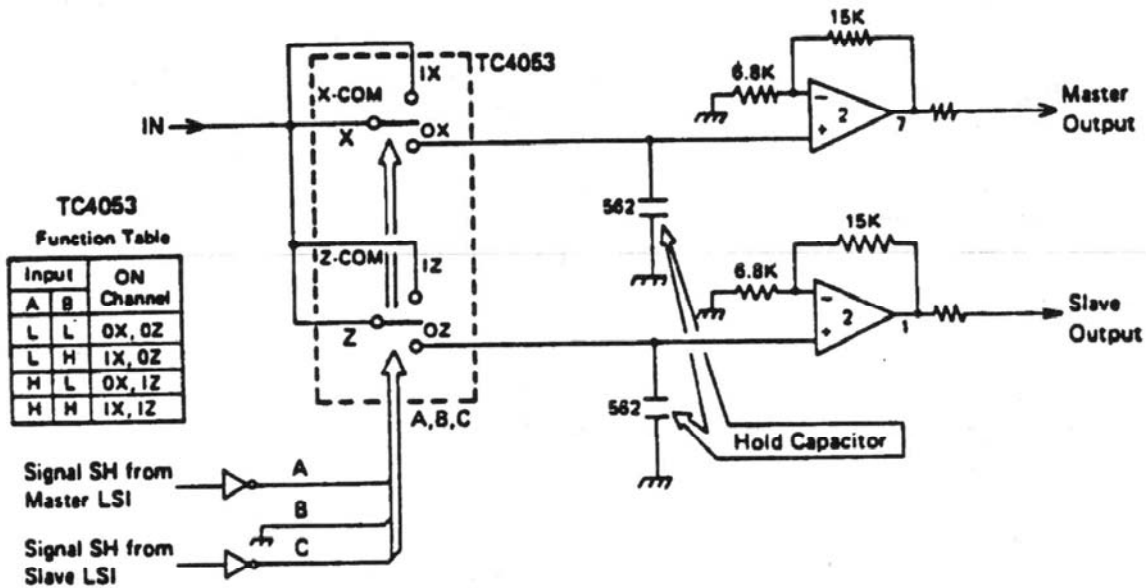

The block eliminates a high frequency noise called as "Glitch" which appears at the end of the stepped waveform.

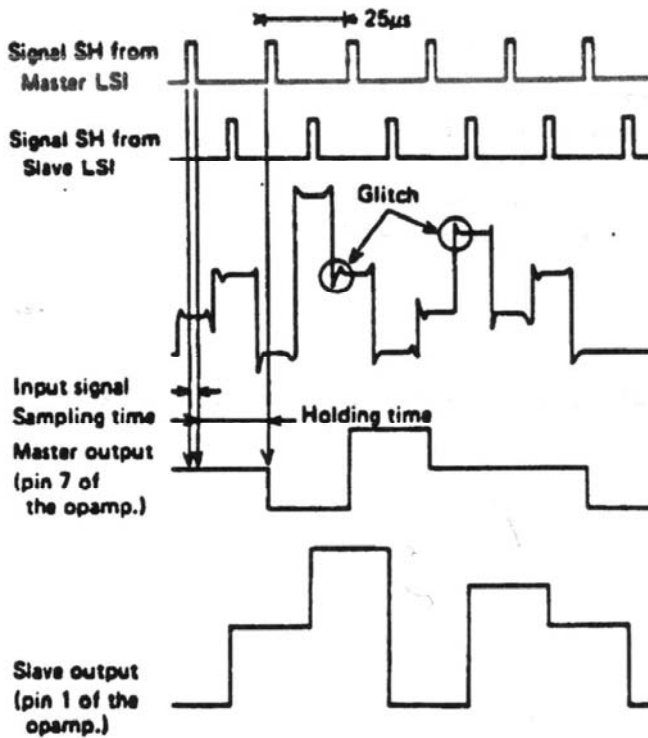

When signal SH from Master LSI is HIGH, the switch X in TC4053 is contacted with the terminal OX. This causes the input signal to pass through. At this time, the voltage level of the waveform is charged in the Hold Capacitor.

On the other hand, while a glitch appears on the waveform, the switch X is contacted with the terminal IX. This results in cutting off the glitch. Although no signal comes out of TC4053, the input of the opamp keeps the same voltage level by discharging of the Hold Capacitor.

Sampling or holding the slave waveform is performed by the same procedures using signal SH from Slave LSI and switch Z.

20. STEREO CHORUS CONTROL CIRCUIT

20-1. Block Diagram

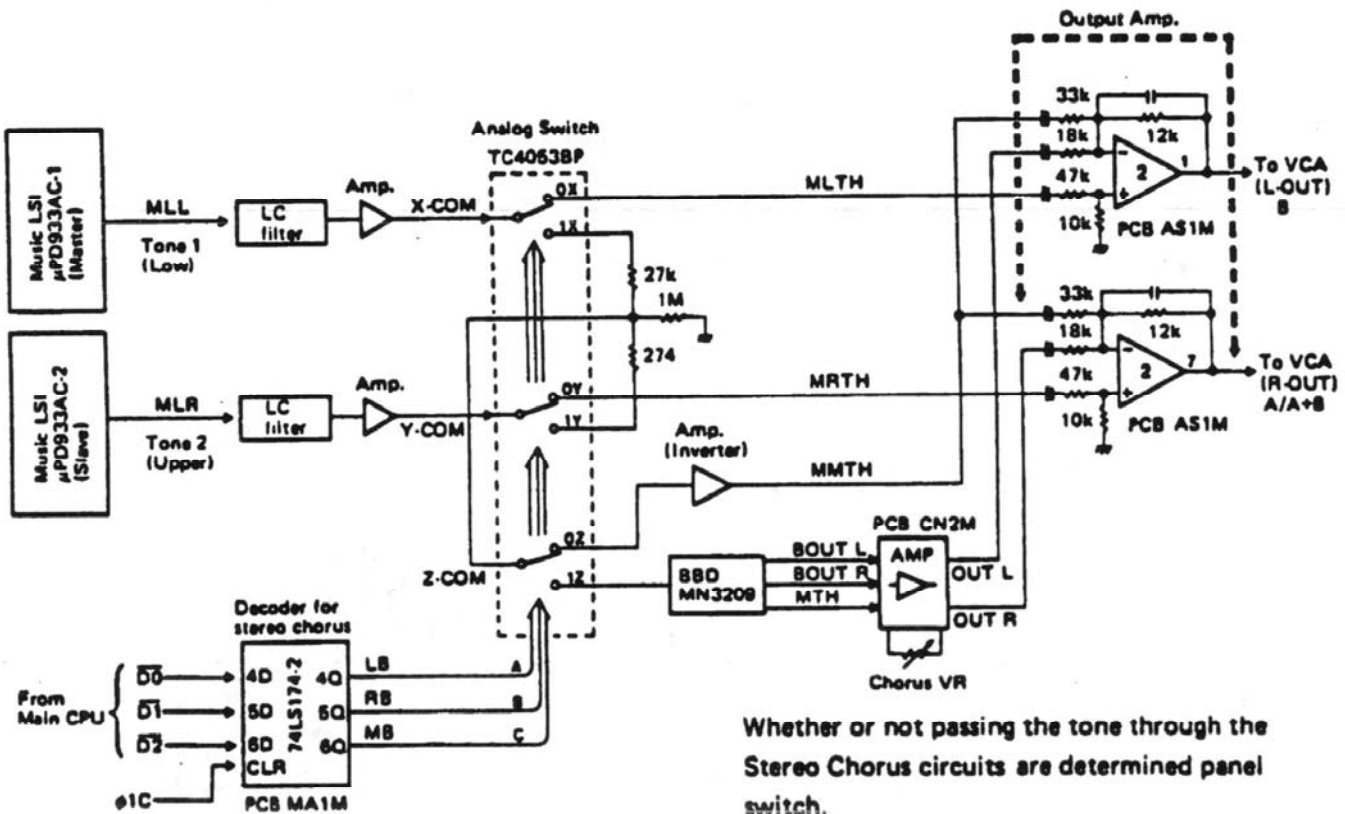

Whether or not passing the tone through the Stereo Chorus circuits are determined panel switch.

The Main CPU controls analog switch TC4053BP to pass only selected tone through Stereo Chorus circuits.

20-2. Signal Function

- ① MLL, MLR Left (Right) analog melody signal of DAC output.
- ② MLTH, MRTH Left (Right) analog melody signal of original sound.
(Not through Stereo Chorus circuit)
- ③ MMTH Mixed (L+R) analog melody signal of original sound.
(Not through Stereo Chorus circuit)
- ④ BOUT L, BOUT R ... Left (Right) analog melody signal of Stereo Chorus sound.
(Through Stereo Chorus circuit)
- ⑤ MTH Mixed (L+R) analog melody signal of original sound for Stereo Chorus sound.
- ⑥ OUT L, OUT R Stereo Chorus sound. (BOUT L (R) + MTH)

20-3. Circuit Function

- ① Decoder for Stereo Chorus Generates control signals for the analog switch.
(SN74LS174N-2)
- ② Analog switch Selects whether or not passing the melody signal through
(TC4053BP) Stereo Chorus circuits.
- ③ BBD (MN3209) Bucket Brigade Device for Stereo Chorus effect.
- ④ Output Amp. Mixes the stereo or monaural signals.

20-4. Line-out Circuit

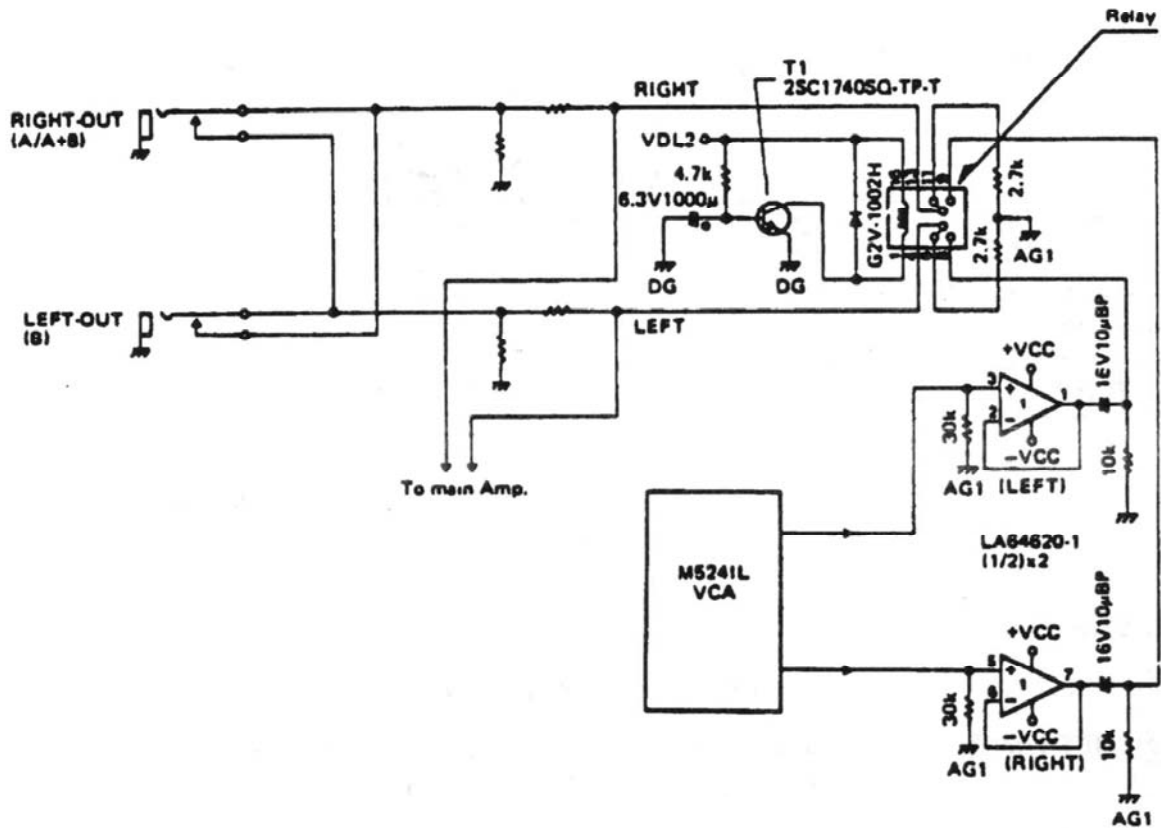

- ① Stereo sounds are output only when output plugs are connected to both A/A+B and B terminals, while mixed sound is heard when output plug is connected only one terminal.
Note: When output plug is connected at B terminal, mixed sound B/A+B is also output.
- ② The relay eliminates a shock noise at power ON/OFF. Voltage level VDL2 is controlled by signal LDC from terminal PB6 of Sub CPU. (Refer to page 19)

The following table shows combinations of the analog switch and the LINE-OUT terminal output in each mode.

MODE	Stereo Chorus ON/OFF	LINE-OUT terminal output		Stereo Chorus VR O: Effective X: No effective	Analog switch TC4053						Melody signal output O: Output X: No output			
		A/A+B (OUT-R)	B (OUT-L)		Input			Output			MRTH	MLTH	MMTH	MTH. B OUT
					C	B	A	X	Y	Z				
NORMAL	ON	OUT L + OUT R	OUT L + OUT R	O	H	H	H	1	1	1	X	X	X	O
	OFF	MMTH	MMTH	X	L	H	H	1	1	0	X	X	O	X
TONE MIX	TONE 1: ON TONE 2: ON	OUT L + OUT R	OUT L + OUT R	TONE 1: O TONE 2: O	H	H	H	1	1	1	X	X	X	O
	TONE 1: ON TONE 2: OFF	OUT R + MRTH	OUT L	TONE 1: O TONE 2: X	H	L	H	1	0	1	O	X	X	O
	TONE 1: OFF TONE 2: ON	OUT R	OUT L + MLTH	TONE 1: X TONE 2: O	H	H	L	0	1	1	X	O	X	O
	TONE 1: OFF TONE 2: OFF	MRTH	MLTH	TONE 1: X TONE 2: X	L	L	L	0	0	0	O	O	X	X
	UPPER: ON LOWER: ON	OUT L + OUT R	OUT L + OUT R	UPPER: O LOWER: O	H	H	H	1	1	1	X	X	X	O
KEY SPRIT	UPPER: ON LOWER: OFF	OUT R	OUT L + MLTH	UPPER: O LOWER: X	H	H	L	0	1	1	X	O	X	O
	UPPER: OFF LOWER: ON	OUT R + MLTH	OUT L	UPPER: X LOWER: O	H	L	H	1	0	1	O	X	X	O
	UPPER: OFF LOWER: OFF	MLTH	MRTH	UPPER: X LOWER: X	L	L	L	0	0	0	O	O	X	X

Note: ① When connecting both A/A+B and B output of LINE-OUT terminal.

Line-out	Mode	Normal	Tone mix	Key sprit
	A/A+B		R-OUT (Output of Music LSI (Master))	Tone 2
B		L-OUT (Output of Music LSI (Slave))	Tone 1	Lower

21. Stereo Chorus Circuit

21.1. BLOCK DIAGRAM

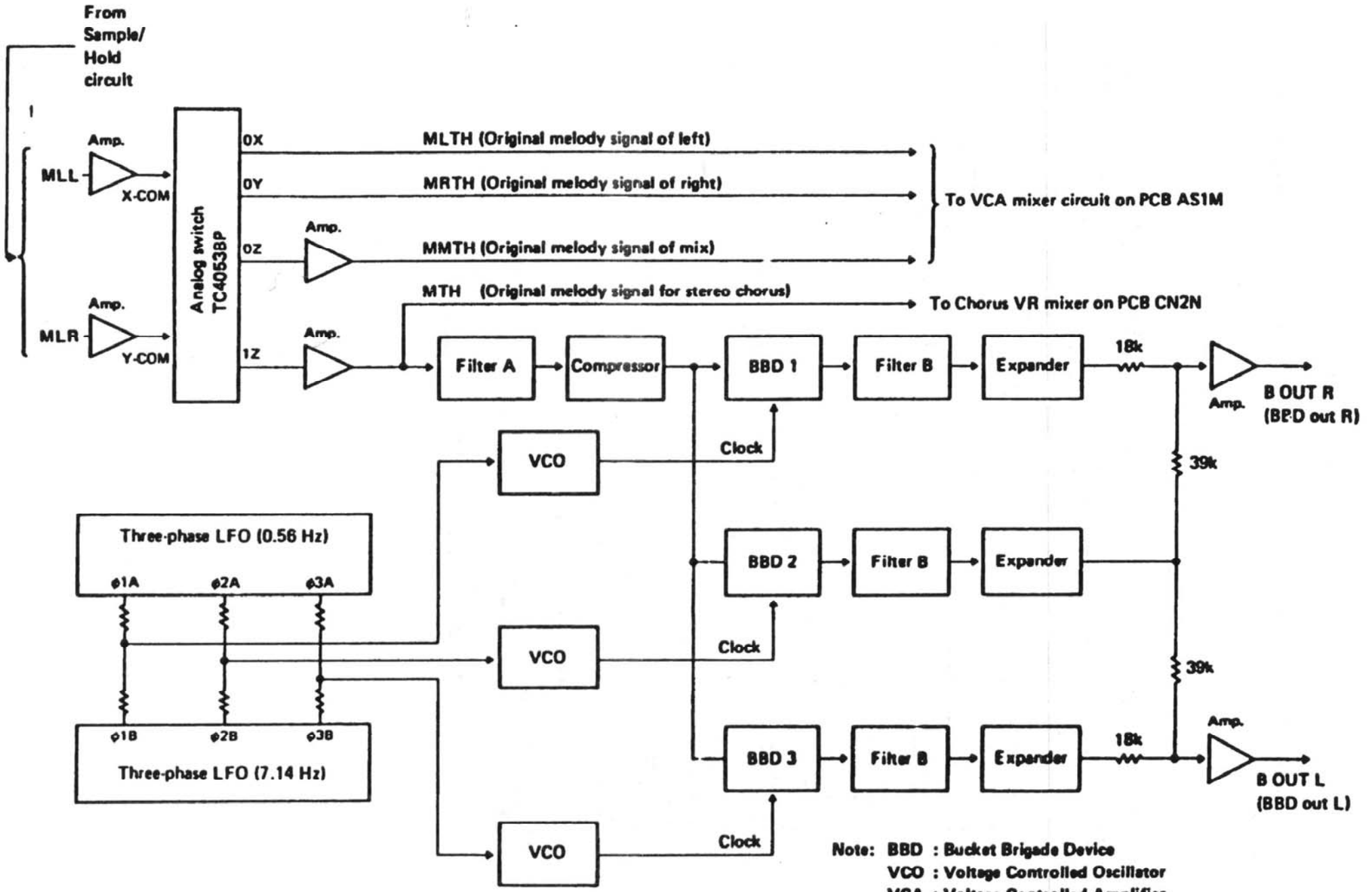

Note: BBD : Bucket Brigade Device
 VCO : Voltage Controlled Oscillator
 VCA : Voltage Controlled Amplifier
 LFO : Low Frequency Oscillator

21-2. Function of Each Block

- Analog switch (TC4053BP)** – Determines whether or not passing melody signal through Stereo Chorus circuits. (Controlled by CPU)
- Filter A** – As the BBD does not pass signals which exceed 20KHz, this block is a low-pass filter whose cutoff frequency is 20KHz.
- Compressor** – In accordance with input signal level, this block controls the amplitude. When the input signal is small, the circuit amplifies the signal whereas the amplitude becomes smaller when the input is a large-level waveform. The block is used for reducing the noise.
- Three-Phase LFOs** – Generates low-frequency triangle signals of 0.56Hz and 7.14Hz. The three outputs differ 120 degrees in phase.
- VCOs** – Voltage Controlled Oscillator which generates the clock pulses for the BBDs. Their oscillation frequencies vary in accordance with the input voltage level.
- BBDs** – Bucket Brigade Device. Stereo chorus effect is given by delaying the right or the left sound.
- Filter B** – Since the output signal of the BBD carries a noise caused by clock pulses, the filter removes the noise.
- Expander** – Functions contrary to the Compressor. This circuit is also used for reducing the noise.

21-3. Three-Phase LFO (Low Frequency Oscillator)

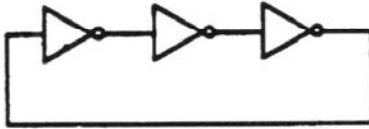

The left figure shows three inverters serially connected. If LOW level input enters the circuit, the output becomes HIGH level. Because of the transfer characteristic of the inverter, the inverted input voltage appears on the output with a time lag.

Hence, the circuit oscillates and the oscillation frequency is determined by the time lag.

The following shows the actual circuit of the Three-Phase LFO. The time lag is controlled by the parallel connected capacitor and the resistors.

Model CZ-1 employs two LFOs whose oscillation frequencies are 0.56 Hz and 7.14 Hz. The output differs 120 degrees in phase.

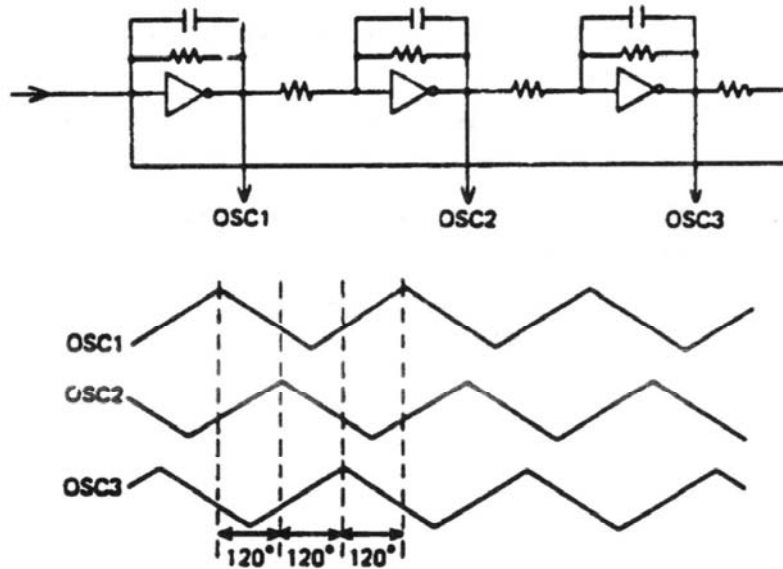

Both 0.56 Hz and 7.14 Hz triangle waveforms are mixed to give variational delays of the sound in the BBD.

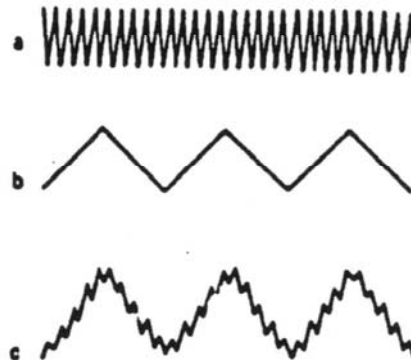
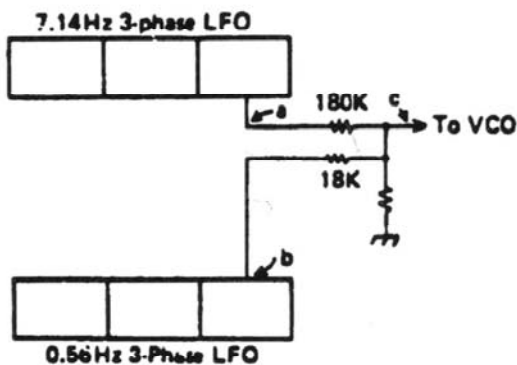

The 0.56 Hz and 7.14 Hz waveforms are mixed in the ratio of 10:1 as they pass through 18Kohm and 180Kohm resistors, respectively.

21-4. VCO (Voltage Controlled Oscillator)

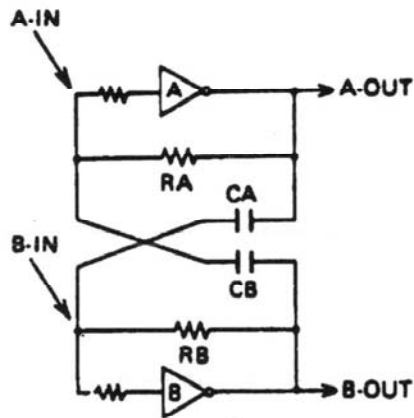

The VCO is an oscillator whose oscillation frequency varies in accordance with the input voltage level.

In the left figure, the voltage levels of the A-OUT and the B-OUT are opposite.

(1) When A-OUT is HIGH, B-OUT drops to LOW.

(2) From A-OUT, electric current flows into B-IN via a differentiation circuit.

As a result, the voltage of B-IN drops gradually while the A-IN voltage gradually rises.

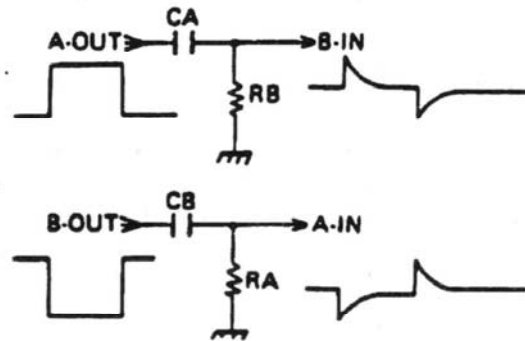
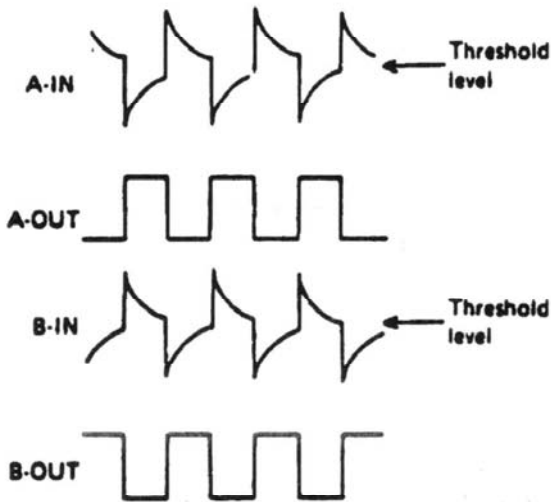

(3) When B-IN becomes lower than the threshold level, B-OUT rises to HIGH.

When A-IN becomes higher than the threshold level, A-OUT drops to LOW.

(4) The circuit oscillates repeating the above operations.

The following shows the actual circuit of VCO. When control terminal (A) is GND (zero volt), it takes approximately 15 microseconds for the differentiation circuit to reach the threshold voltage.

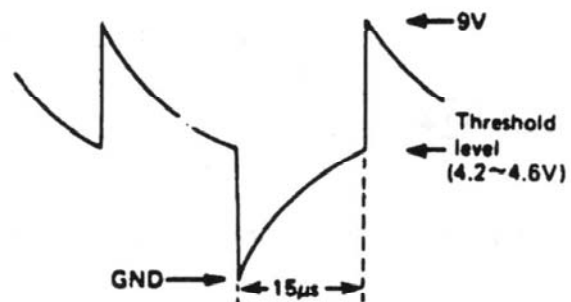
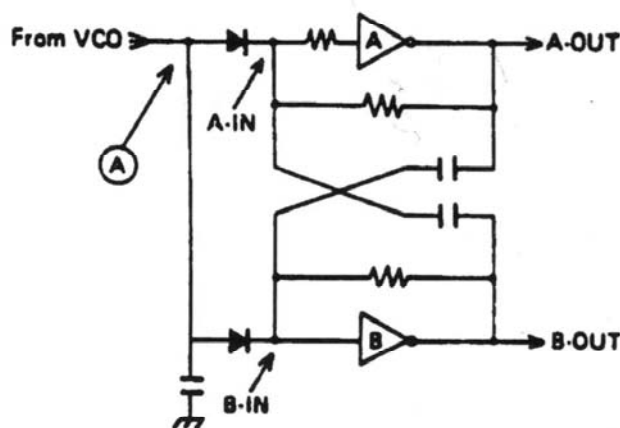

When the voltage of (A) is 2 volts, it takes only 9 microseconds to reach the threshold level.

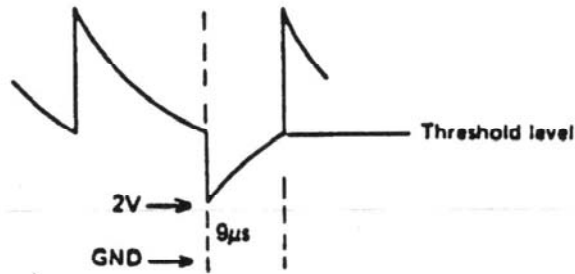

As VCO receives a triangle waveform from the Three-Phase LFO, it oscillates from 55.6 KHz to 33.3 KHz in accordance with the voltage level of LFO output.

21-5. BBD (Bucket Brigade Device)

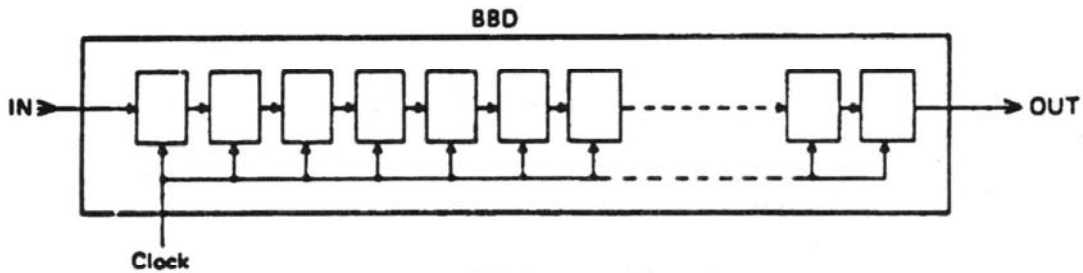

The BBD contains serial-connected delay elements. The input signal is shifted one step per one clock pulse.

The clock pulse is generated in the VCO, and as it varies from 33.3KHz to 55.6KHz, the delay time varies.

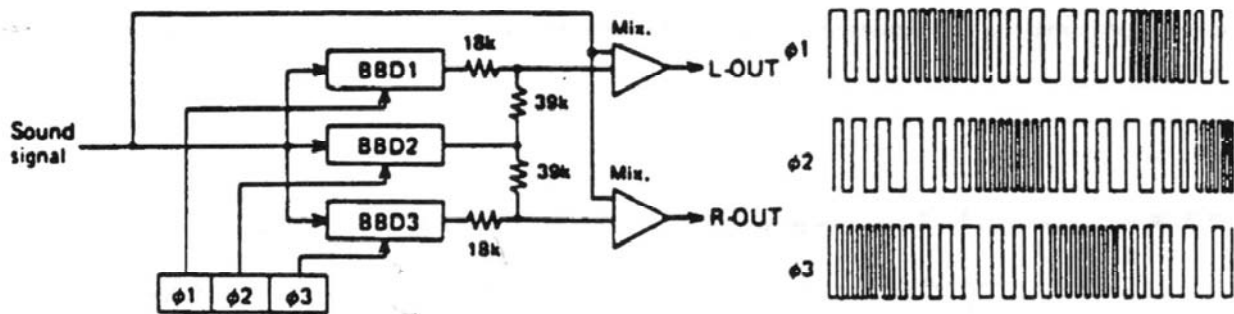

Model CZ-1 employs three BBDs in order to give better stereo effect.

21-6. Compressor and Expander Circuits

If a sound signal passes through the BBD, a noise is carried on the signal especially when the input level of the signal is low.



Compressor When the level of input signal is low, the amplitude is large.
If the input level is high, the amplitude decreases.

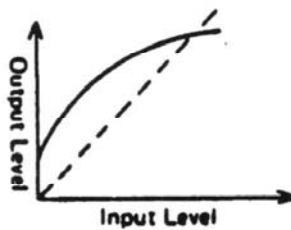

Expander When the level of input signal is low, the amplitude is small.
The amplitude increases when the input level is high.

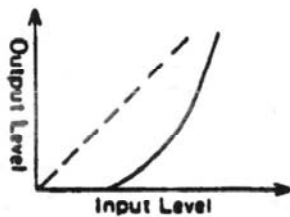

When a low signal does not pass through the Compressor and the Expander;

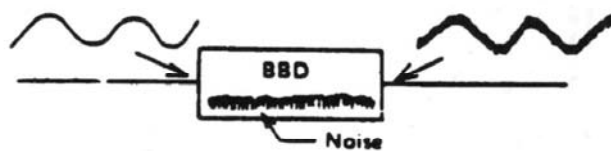

When a low signal passes through the Compressor and the Expander;

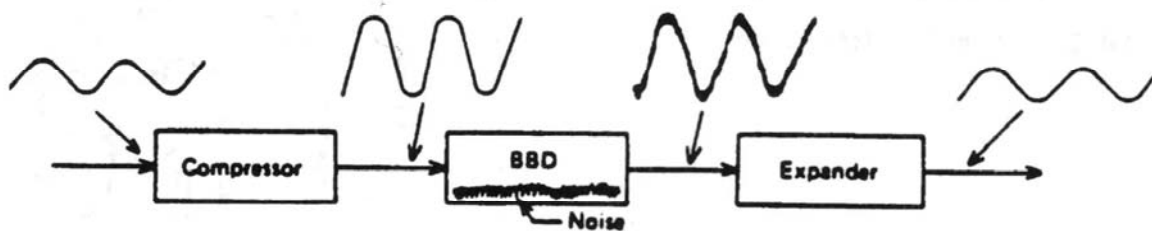

Thus, the S/N ratio of the circuit is heightened.

22. OUTPUT VOLUME CONTROL CIRCUIT

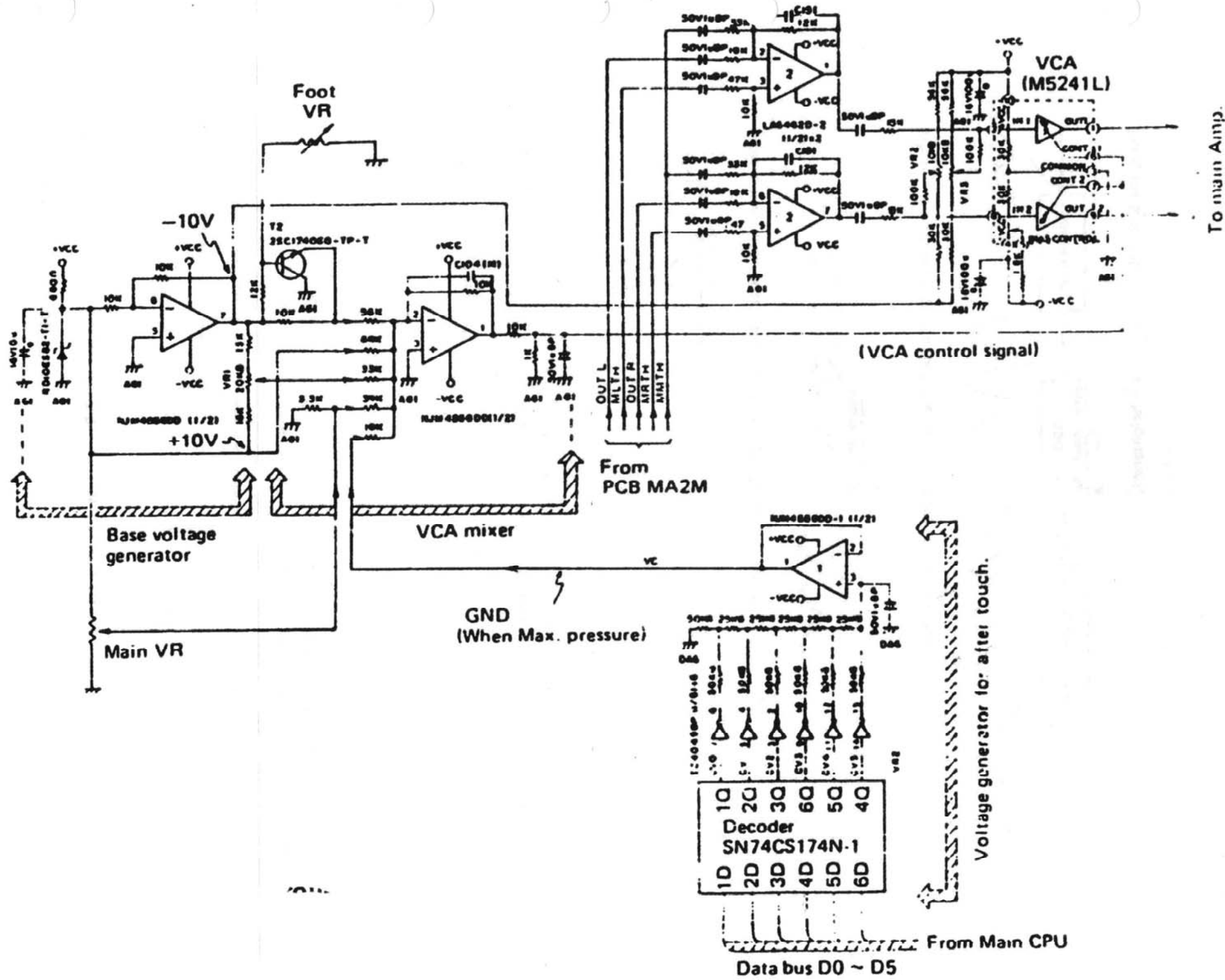

To main Amp.

Voltage generator for after touch.

From Main CPU

Data bus D0 ~ D5

Output volume is controlled by VCA
(Voltage Controlled Amplifier) M5241L.

The VCA amplitude is controlled by
VCA control signal which is generated
by VCA mixer.

The VCA mixer output is controlled
by foot VR, main VR, and after touch sensor, and varies its output voltage in negat
Besides, VCA control signal is also varied by Amp. or after touch parameter.

	Main VR	Pressure of after touch sensor	Amp./After touch parameter				
			15	~	8	~	0
VCA control signal	Min.	No pressure	-4.6V	~	-3.6V	~	-2.5V
	Max.	No pressure	-2.0V	~	-1.0V	~	+0.2V
	Max.	Max. pressure	+0.2V	~	+0.2V	~	+0.2V

23. RESET CIRCUIT

The following circuit is Reset (power fail detection) circuit which generates power ON/OFF reset pulse for peripheral LSIs (CPUs, Music LSIs, Key interface LSI, and Key touch control LSI), to protect recorded data in the RAM's.

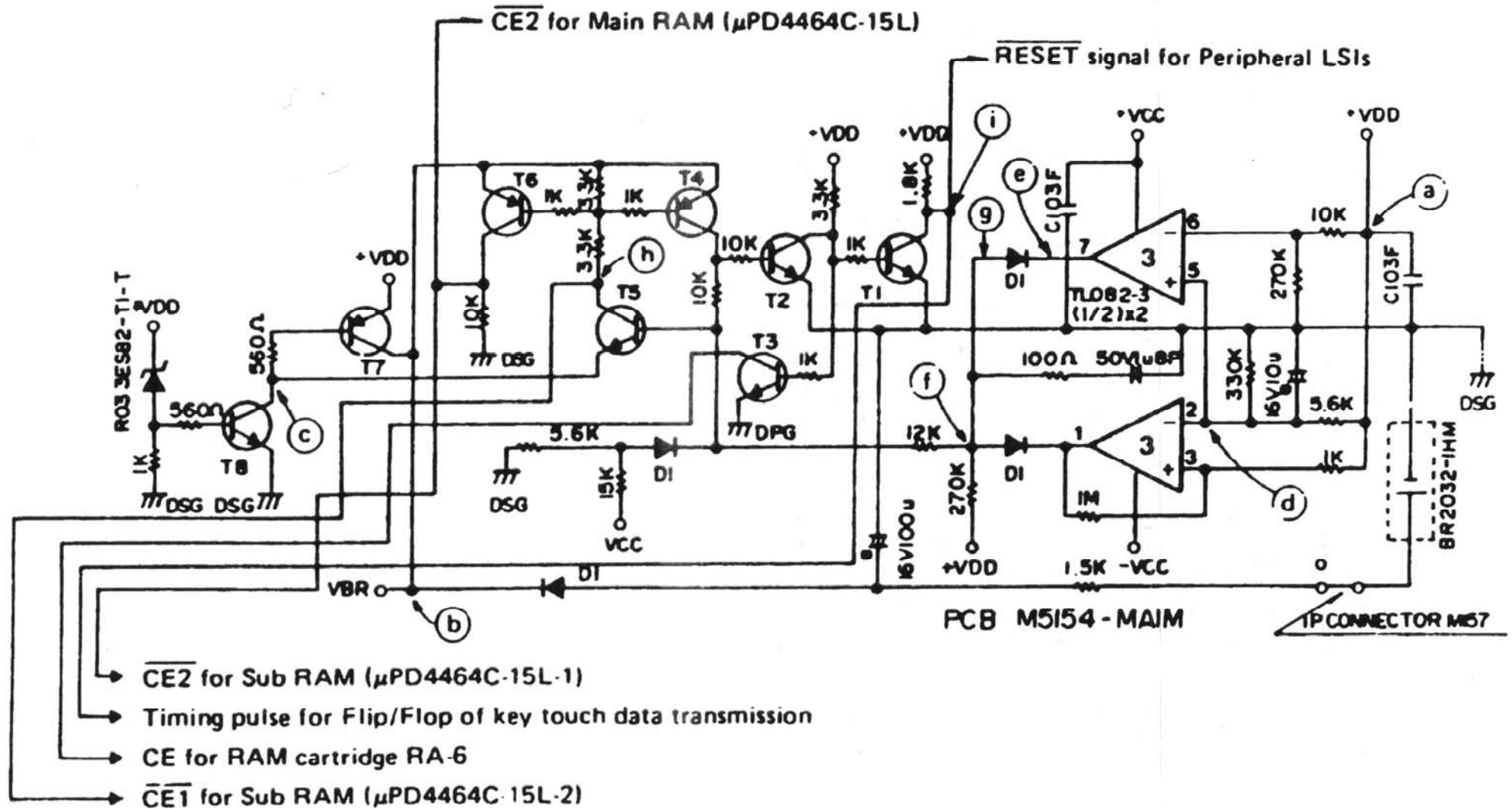

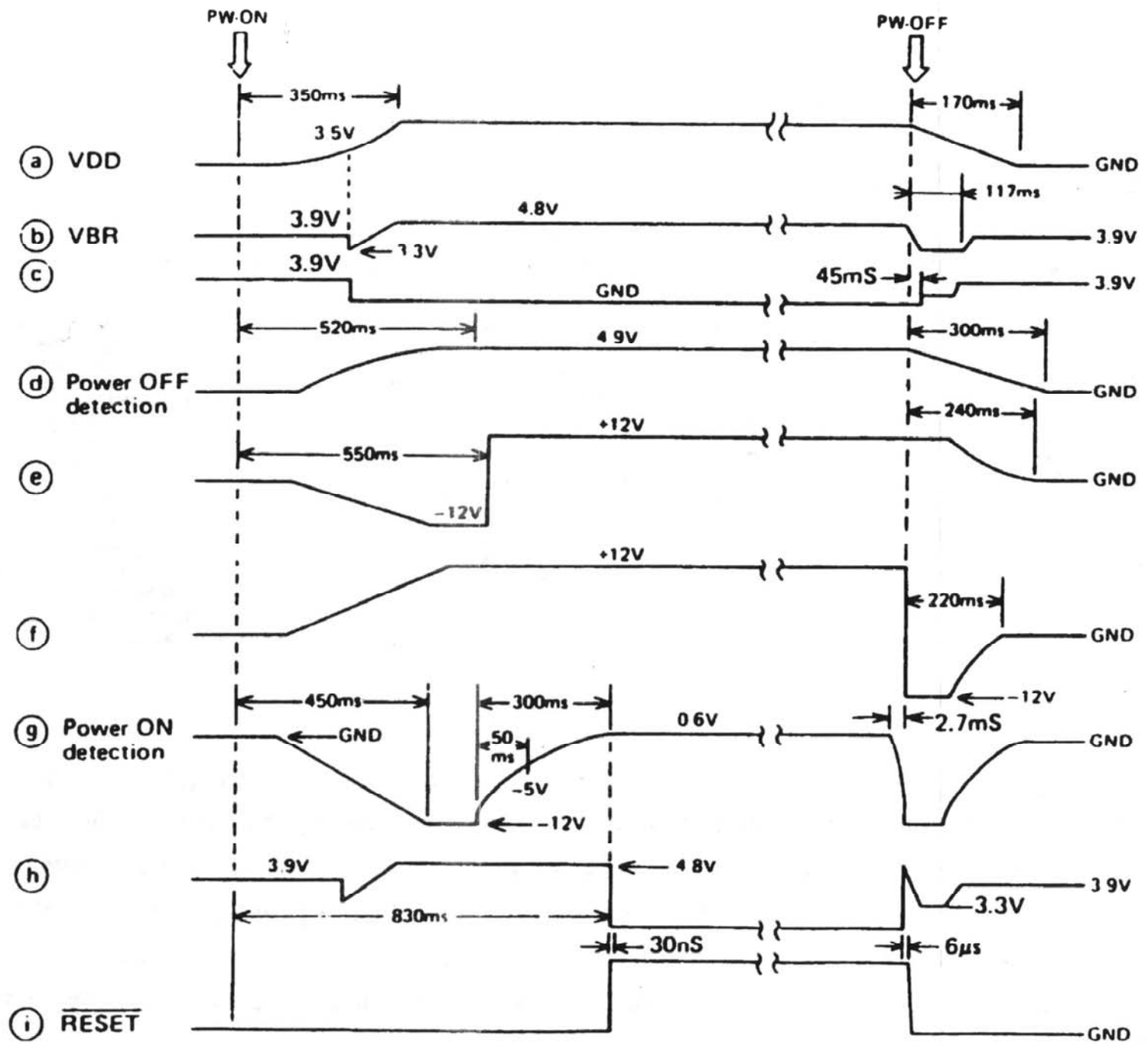

24. MIDI INTERFACE CIRCUIT

MIDI (Musical Instrument Digital Interface) is an international standard for external control of electronic musical instruments. In other words, standardized input and output terminals are equipped with musical instruments, rhythm machines, sequencers, etc. and music information which the machines send and receive via these terminals is made compatible by certain formatting. This standard enables a musical instrument to connect, synchronize, and sequence (memorize) to other models and even to other makes.

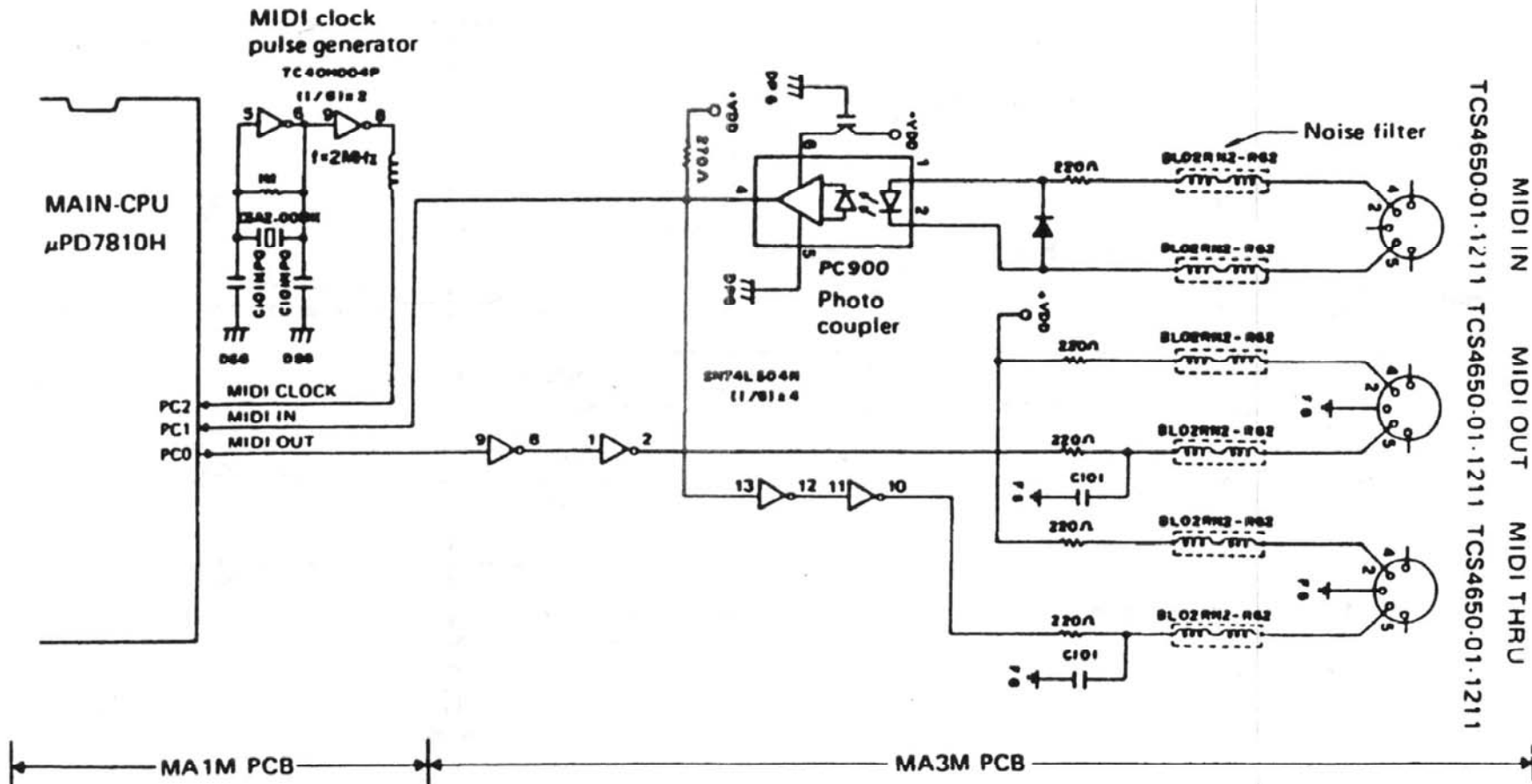

Serial data informations from other instruments comes in from MIDI-IN terminal and enters MAIN CPU's PC1 terminal via photo coupler PC900.

Thus, CZ-1 is not electrically connected with any external instruments to cut electric noises.

Input signal also goes out MIDI THRU terminal through a photo coupler and two inverters.

MAIN CPU transmits MIDI data from PC0 terminal.

25. ADJUSTMENT

25-1. DAC Offset Voltage Adjustment

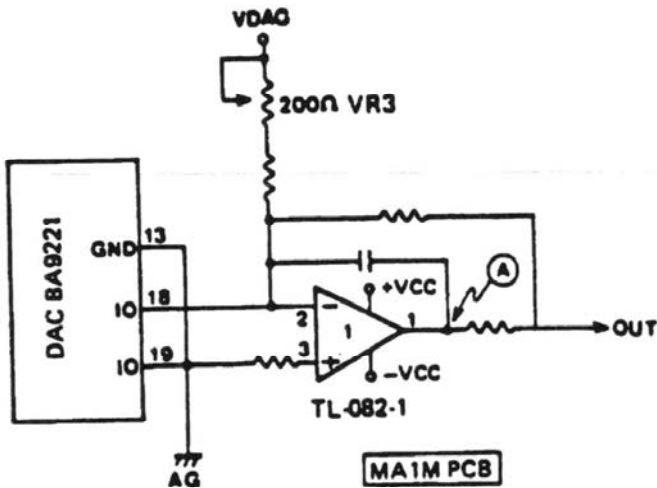

(1) Connect a digital voltmeter between pin 13 of DAC BA9221 and pin 1 of opamp TL082-1.

(Refer to check point (A) on page 11)

(2) While the test unit is not producing any sound, adjust VR3 so that the digital voltmeter reading is $-3 \pm 3\text{mV}$.

Note: Be sure to use a digital voltmeter.

25-2. VSS1 Voltage Adjustment (Power Source for MSM6200)

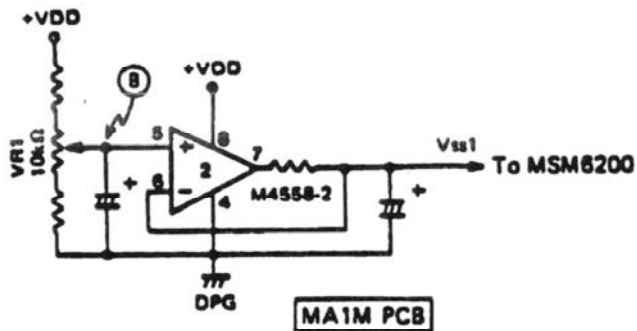

(1) Measure VDD (+5V) accurately.

(2) Connect a digital voltmeter between pin 5 of opamp M4558-2 and ground DPG. (Refer to check point (B) on page 11)

(3) Adjust VR1 so that Vss1 is $2.25 \pm 0.05\text{V}$.

Note: Be sure to use a digital voltmeter.

25-3. LCD Brightness Adjustment

Turn the VR2 on PCB MA1M all the way counter clockwise.

25-4. After Touch Adjustment

Turn the VR4 on PCB MA1M all the way clockwise.

25-5. VCA Offset Voltage Adjustment

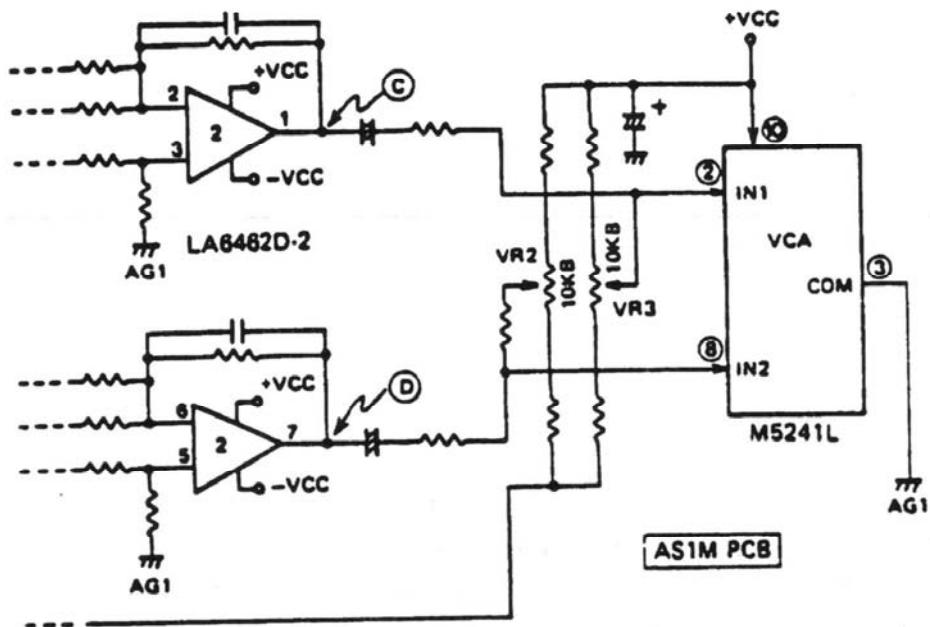

- (1) Connect a digital voltmeter as indicated in the following table. (Refer to checkpoint (C) and (D) on page 4)

Connection point	VR to be adjusted
Pin 1 of opamp and pin (3) of VCA (GND)	VR2
Pin 7 of opamp and pin (3) of VCA (GND)	VR3

- (2) While the test unit is not producing any sound, adjust VR2 and VR3 so that digital voltmeter reading is $0 \pm 3\text{mV}$.

Note: Be sure to use a digital voltmeter.

25-6. BBD Adjustment

- (1) Connect an oscilloscope as shown in the table below. (Refer to checkpoint (E), (F) and (G) on page 12)

Connection point (MA2M PCB)	Adjustment VR
Center terminal of VR1 and pin 1 of BBD MN3209-1 (GND)	VR1
Center terminal of VR2 and pin 1 of BBD MN3209-2 (GND)	VR2
Center terminal of VR3 and pin 1 of BBD MN3209-3 (GND)	VR3



MA2M PCB

- (2) Set the oscilloscope on AC range, 0.1V/div , and $10\mu\text{S/div}$, then observe the waveforms.

- (3) Adjust each VR for the minimum width of the waveform.

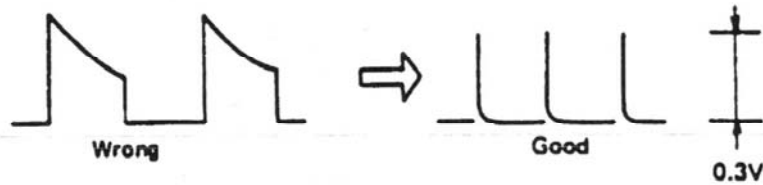

25-7. Volume Adjustment

- (1) Keep pressing "INITIALIZE" button, depress "DC01 WAVEFORM", "DC01 ENVELOPE", "DCW1 KEY FOLLOW", "DCW1 ENVELOPE", "DCA1 KEY FOLLOW", "DCA1 ENVELOPE", "DETUNE", and "OCTAVE" buttons on "NORMAL" mode.
- (2) Depress "DCW1 ENVELOPE" and then "END" buttons.
- (3) Choose 1+1' by "LINE SELECT" button.
- (4) Set the volume control to its maximum and the stereo chorus volume to its minimum.
- (5) Connect a digital voltmeter and a resistor of $47K\Omega$ between the ground and LINE-OUT terminal (either A/A+B or B output).
- (6) Depressing the key A3, adjust 50K VR on the PCB M5153-AS1M so that the voltmeter reading is $340mV \pm 20mV$.

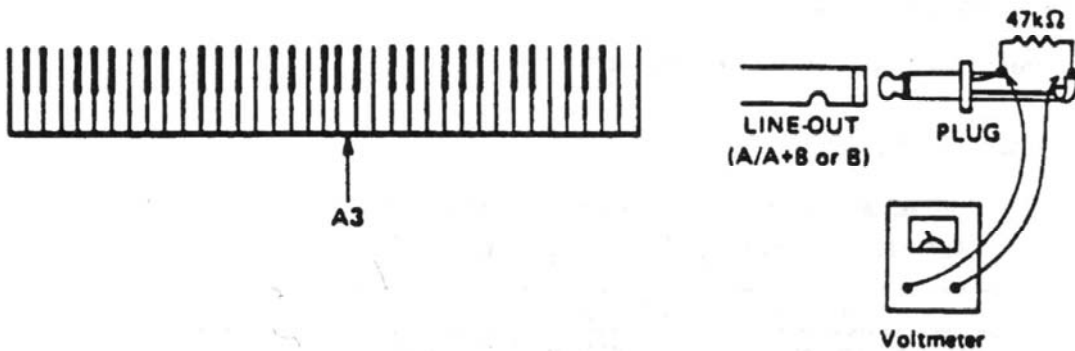

1) Price Codes subject to change without notice.

2) Refer to current Technical News Bulletins for price code values.

CZ-1 Parts List

Item	Code No.	Part Name	Specification	Q'ty	Price Code	Rank
	(1)	M5154-MA1M PCB ASS'Y				
	2002 1420	LSI (Melody LSI)	μPD933AC	2	BA	B
☆	2010 0105	LSI (Key interface LSI)	μPD8049HC-672	1	AU	B
☆	2010 0112	LSI (RAM)	μPD4464C-15L	3	AW	B
☆	2010 0322	LSI (CPU)	μPD7810HG-36	2	BB	B
☆	2010 1176	LSI (Main ROM)*New Version	μPD27C256C-20A154	1	AV	B
☆	2010 0336	LSI (Sub ROM)	μPD23C128EC-036	1	AS	B
	2001 0525	C MOS IC	M864H173	1	AU	A
	2100 3786	C MOS IC	TC40H004P	1	AE	A
	2100 4029	C MOS IC	TC40518P	1	AG	A
	2100 4472	C MOS IC	TC74HCU04P	2	AE	A
	21116092	C MOS IC (SN74HC32N)	TC74HC32P	1	AE	A
	2100 3255	MOS IC	TC40498P	1	AE	A
	2100 3808	IC	TC40538P	1	AI	A
	2111 2496	IC	SN74LS174N	3	AK	A
	2111 2615	IC	SN74LS05N	1	AF	A
	2110 3756	Bipolar IC	SN74LS04N	2	AF	A
	2111 2180	Bipolar IC	SN74LS32N	2	AF	A
	2111 2178	Bipolar IC	SN74LS74AN	2	AG	A
	2111 2194	Bipolar IC	SN74LS138N	1	AG	A
	2111 2283	Bipolar IC	SN74LS08N	1	AF	A
	2111 5177	Bipolar IC	SN74LS240N	1	AK	A
	2111 5291	Bipolar IC	SN74LS139N	1	AH	A
	2111 5509	Bipolar IC	SN74LS374N	1	AN	A
	21210013	Monolithic IC (NJM455800)	BA4558CA	2	AD	A
	21209244	Monolithic IC	TL082 (TL082CP)	3	AF	A
	2122 0221	D/A Converter	BA9221	1	AP	A
	2184 1014	Bipolar IC	HD74LS154P	2	AH	A
	22009010	Transistor	2SA933	5	AD	A
	22209035	Transistor	2SC1740	6	AD	A
	2301 0291	Diode	1SS270	9	AA	C
	23103273	Zener diode	RD5.6E	1	AA	A
	23104512	Zener diode	RD3.3E	1	AA	A
☆	3025 0063	Capacitor EMI filter	DST306-56FZ103Z	1	AC	X
	38001752	Lithium Battery	BR2032-1HM		AG	A
	2520 1485	Ceramic oscillator	CSA2.00MK	1	AG	
☆	2590 0007	Ceramic oscillator	CSA2.47MG	1	AE	

Note: ☆ - New parts

Q'ty - Quantity used per unit

Rank A: Essential
B: Stock recommended
C: Others
X: No stock recommended

*Old Version Main ROM (UPD23C256E-133)

CZ-1 Parts List

Item	Code No.	Part Name	Specification	Q'ty	Price Code	Rank
	2520 3194	Crystal oscillator	HC-18/U-8960KHz	1	AH	C
*	2590 0042	Crystal oscillator	NR-18-15.000MHz	1	AG	C
	2760 2177	Trimmer VR (10Kohm)	V8K4-11B10K	3	AB	B
	2760 2258	Trimmer VR (200ohm)	V8K4-11B200	1	AB	B
	3020 2147	Ferrite beads	BL02RN2-R62	7	AB	X
	0002 8723	Carbon film resistor	R-20-100-J (1/5W, 100ohm, ±5%)	2	N/A	X
	0002 8724	Carbon film resistor	R-20-220-J (1/5W, 220ohm, ±5%)	1		
	0002 8725	Carbon film resistor	R-20-560-J (1/5W, 560ohm, ±5%)	2		
	0002 8726	Carbon film resistor	R-20-1K-J (1/5W, 1Kohm, ±5%)	49		
	0002 8727	Carbon film resistor	R-20-2.2K-J (1/5W, 2.2Kohm, ±5%)	2		
	0002 8729	Carbon film resistor	R-20-10K-J (1/5W, 10Kohm, ±5%)	6		
	0002 8730	Carbon film resistor	R-20-33K-J (1/5W, 33Kohm, ±5%)	1		
	0002 8731	Carbon film resistor	R-20-47K-J (1/5W, 47Kohm, ±5%)	2		
	0002 8733	Carbon film resistor	R-20-100K-J (1/5W, 100Kohm, ±5%)	1		
	0002 8736	Carbon film resistor	R-20-1M-J (1/5W, 1Mohm, ±5%)	6		
	0002 8737	Carbon film resistor	R-20-1.8K-J (1/5W, 1.8Kohm, ±5%)	1		
	0002 8946	Carbon film resistor	R-20-3.3K-J (1/5W, 3.3Kohm, ±5%)	24		
	0002 8951	Carbon film resistor	R-20-12K-J (1/5W, 12Kohm, ±5%)	3		
	0002 8953	Carbon film resistor	R-20-120K-J (1/5W, 120Kohm, ±5%)	2		
	0002 8954	Carbon film resistor	R-20-5.6K-J (1/5W, 5.6Kohm, ±5%)	3		
	0002 8956	Carbon film resistor	R-20-22K-J (1/5W, 22Kohm, ±5%)	1		
	0002 8960	Carbon film resistor	R-20-56-J (1/5W, 56ohm, ±5%)	1		
	0002 9000	Carbon film resistor	R-20-820-J (1/5W, 820ohm, ±5%)	3		
	0002 9001	Carbon film resistor	R-20-22-J (1/5W, 22ohm, ±5%)	1		
	0002 9002	Carbon film resistor	R-20-15K-J (1/5W, 15Kohm, ±5%)	1		
	0002 9003	Carbon film resistor	R-20-1.2K-J (1/5W, 1.2Kohm, ±5%)	1		
	0002 9004	Carbon film resistor	R-20-270K-J (1/5W, 270ohm, ±5%)	2		
	0002 9005	Carbon film resistor	R-20-330K-J (1/5W, 330Kohm, ±5%)	1		
	0002 9006	Carbon film resistor	R-20-8.2K-J (1/5W, 8.2Kohm, ±5%)	1		
	0002 9007	Carbon film resistor	R-20-47-J (1/5W, 47ohm, ±5%)	1		
	0002 9019	Carbon film resistor	R-20-12K-J (1/5W, 12Kohm, ±5%)	1		
*	0002 9021	Carbon film resistor	R-20-8.8K-J (1/5W, 8.8Kohm, ±5%)	2		
	0002 9024	Carbon film resistor	R-20-1.5K-J (1/5W, 1.5Kohm, ±5%)	1		

Note: * - New parts

Q'ty - Quantity used per unit

Rank A: Essential

B: Stock recommended

C: Others

X: No stock recommended

CZ-1 Parts List

Item	Code No.	Part Name	Specification	Q'ty	Price Code	Rank
	0002 9104	Carbon film resistor	R-20-330-J (1/5W, 330ohm, ±5%)	1	N/A	X
☆	0002 9253	Carbon film resistor	R-20-25K-G(1/5W, 25kohm, ±2%)	5		
☆	0002 9254	Carbon film resistor	R-20-82-J (1/5W, 82ohm, ±5%)	1		
☆	0002 9255	Carbon film resistor	R-20-50K-G (1/5W, 50Kohm, ±2%)	7		
	0002 9027	Metal film resistor	CRB20FX5K (1/5W, 5Kohm, ±1%)	5		
	0002 9028	Metal film resistor	CRB20FX10K (1/5W, 10Kohm, ±1%)	3		
	0002 9029	Metal film resistor	CRB20FX5.6K (1/5W, 5.6Kohm, ±1%)	2		
	0002 9030	Metal film resistor	CRB20FX2.7K (1/5W, 2.7Kohm, ±1%)	1		
	0002 8886	Electrolytic capacitor	50RE2-1 (50V, 1μF, ±20%)	3		
	0002 8887	Electrolytic capacitor	16RE2-100 (16V, 100μF, ±20%)	2		
	0002 8888	Electrolytic capacitor	6.3RE2-100 (6.3V, 100μF, ±20%)	4		
	0002 8965	Electrolytic capacitor	6.3RE2-470 (6.3V, 470μF, ±20%)	3		
	0002 9063	Electrolytic capacitor	16RE2-10 (16V, 10μF, ±20%)	4		
☆	0002 9084	Electrolytic capacitor	6.3RE2-47 (6.3V, 47μF, ±20%)	1		
☆	0002 9257	Electrolytic capacitor	16RE2-33 (16V, 33μF, ±20%)	1		
	2804 9013	Electrolytic capacitor	50RNBBP1 (50V, 1μF, ±20%)	1		
	0002 9250	Ceramic capacitor	HE40SJCH300J (50V, 30pF, ±5%)	2		
	2818 0012	Ceramic capacitor	HE40SJYB101K (50V, 100pF, ±10%)	3		
	2818 0055	Ceramic capacitor	HE40SJYB221K (50V, 220pF, ±10%)	3		
	2818 2040	Ceramic capacitor	HE40SJYF103Z (50V, 0.01μF, ⁺⁸⁰ / ₋₂₀ %)	17		
	2818 3054	Ceramic capacitor	HE80SJCH101J (50V, 100pF, ±5%)	2		
	2818 3097	Ceramic capacitor	HE40SJCH220J (50V, 22pF, ±5%)	2		
	2818 3119	Ceramic capacitor	HE40SJCH150J(950V, 15pF, ±5%)	2		
	2818 6045	Ceramic capacitor	HE40SJS�680K(50V, 68pF, ±10%)	1		
	2818 6191	Ceramic capacitor	HE40SJS�220K(50V, 22pF, ±10%)	1		
	2860 1069	Three polarity capacitor	DS310-56D223S (50V, 0.022μF, ±20%)	32		
	0002 9027	Metal film resistor	CRB20FX5K(1/5W, 5Kohm, ±1%)	5		
	0002 9028	Metal film resistor	CRB20FX5K(1/5W, 5Kohm, ±1%)	3		
	0002 9029	Metal film resistor	CRB20FX5.6K (1/5W, 5.6Kohm, ±1%)	2		
	2720 3871	Module resistor	MS2238F (1/18[W], 2.2Kohm, ±20%)	1	✓	✓

Note: ☆ - New parts
Q'ty - Quantity used per unit

Rank A: Essential
B: Stock recommended
C: Others
X: No stock recommended

CZ-1 Parts List

Item	Code No.	Part Name	Specification	Q'ty	Price Code	Rank
	27202811	Module resistor	MS4736F (MS4736) (1/16[W], 4.7Kohm, ±20%)	1	AB	C
☆	2725 0014	Module resistor	MS33210F (1/16[W], 3.3Kohm, ±20%)	2	AC	C
	27201962	Module resistor	MS2238F (MS2238) (1/16[W], 22Kohm, ±20%)	1	AB	C
	3500 3371	Connector 2P	IL-G-2P-S3T2-E	1	AA	X
	3500 3401	Connector 4P	IL-G-4P-S3T2-E	1	AB	X
	3500 3873	Pin ass'y 10P	IL-G-10P-S3T2-E	1	AB	X
	3500 7032	P C B connector	5229-13-CPB	1	-	X
	3500 7075	P C B connector	5229-19-CPB	1	-	X
	3500 7491	P C B connector 14P	IL-G-14P-S3T2-E	2	AD	X
	3500 7505	P C B connector 6P	IL-G-6P-S3T2-E	1	AC	X
	3500 8055	Pin	RT-01T01.0B	2	-	X
	3500 8495	1P connector	SMF-1P-6-M157	1	-	X
☆	3501 G028	P C B connector	ZC-015	2	-	X
	3511 0879	P C B connector	5299-14-CPB	1	-	X
	3511 3887	P C B connector	5229-20-CPB	5	-	X
(2) M5154-MA2M PCB ASS'Y						
	2100 3662	MOS IC	TC4069UBP	3	AE	A
	2100 3808	IC	TC4053BP	1	AI	A
	2100 7892	MOS IC (BBD)	MN3209	3	AL	A
	21103322	Bipolar IC	SN74LS1.5N (SN7407N)	1	AE	A
	21210013	Monolithic IC	BA4558CA (NJM4558DD)	4	AD	A
☆	2114 0021	Monolithic IC	LA6462D	5	AE	A
	2002 1144	LSI (Expander)	μPD1571C	2	AM	B
	22209035	Transistor	2SC1740	4	AD	A
	2301 0291	Diode	1SS270	21	AA	C
	2760 2177	Trimmer VR	V8K4-11B10K	3	AB	B
	0002 8723	Carbon film resistor	R-20-100-J (1/5W, 100ohm, ±5%)	2	N/A	X
	0002 8728	Carbon film resistor	R-20-1K-J (1/5W, 1Kohm, ±5%)	18	↓	↓
	0002 8728	Carbon film resistor	R-20-4.7K-J (1/5W, 4.7Kohm, ±5%)	3	↓	↓
	0002 8729	Carbon film resistor	R-20-10K-J (1/5W, 10Kohm, ±5%)	11	↓	↓
	0002 8730	Carbon film resistor	R-20-33K-J (1/5W, 33Kohm, ±5%)	6	↓	↓
	0002 8731	Carbon film resistor	R-20-47K-J (1/5W, 47Kohm, ±5%)	6	↓	↓

Note: ☆ - New parts
Q'ty - Quantity used per unit

Rank A: Essential
B: Stock recommended
C: Others
X: No stock recommended

CZ-1 Parts List

Item	Code No.	Part Name	Specification	Q'ty	Price Code	Rank
	0002 8734	Carbon film resistor	R-20-150K-J (1/5W, 150Kohm, ±5%)	9	N/A	X
	0002 8735	Carbon film resistor	R-20-220K-J (1/5W, 220Kohm, ±5%)	4		
	0002 8738	Carbon film resistor	R-20-1M-J(1/5W, 1Mohm, ±5%)	1		
	0002 8738	Carbon film resistor	R-20-39K-J (1/5W, 39Kohm, ±5%)	2		
	0002 8946	Carbon film resistor	R-20-3.3K-J (1/5W, 3.3Kohm, ±5%)	5		
	0002 8947	Carbon film resistor	R-20-88K-J (1/5W, 88Kohm, ±5%)	3		
	0002 8956	Carbon film resistor	R-20-22K-J (1/5W, 22Kohm, ±5%)	18		
	0002 8957	Carbon film resistor	R-20-56K-J (1/5W, 56Kohm, ±5%)	4		
	0003 8958	Carbon film resistor	R-20-560K-J (1/5W, 560Kohm, ±5%)	3		
	0002 8959	Carbon film resistor	R-20-2.2M-J (1/5W, 2.2Mohm, ±5%)	3		
	0002 8983	Carbon film resistor	R-20-18K-J (1/5W, 18Kohm, ±5%)	7		
	0002 9001	Carbon film resistor	R-20-22-J (1/5W, 22ohm, ±5%)	3		
	0002 9002	Carbon film resistor	R-20-15K-J (1/5W, 15Kohm, ±5%)	3		
	0002 9003	Carbon film resistor	R-20-1.2K-J(1/5W, 1.2Kohm, ±5%)	1		
	0002 9007	Carbon film resistor	R-20-47-J (1/5W, 47ohm, ±5%)	1		
	0002 9011	Carbon film resistor	R-20-27K-J (1/5W, 27Kohm, ±5%)	8		
	0002 9023	Carbon film resistor	R-20-180K-J (1/5W, 180Kohm, ±5%)	7		
	0002 8886	Electrolytic capacitor	50RE2-1 (50V, 1μF, ±20%)	3		
	0002 8888	Electrolytic capacitor	16RE2-100 (16V, 100μF, ±20%)	2		
	0002 9083	Electrolytic capacitor	16RE2-10 (16V, 10μF, ±20%)	10		
	0002 9111	Electrolytic capacitor	16RE2-47 (16V, 47μF, ±20%)	8		
	0002 9258	Elect.olytic capacitor	16RNBBP3R3 (16V, 3.3μF, ±20%)	7		
	2804 9013	Electrolytic capacitor	50RNBBP1 (50V, 1μF, ±20%)	10		
	2805 2210	Electrolytic capacitor	16RE2-470-S1 (16V, 470μF)	1		
☆	0002 9261	Ceramic capacitor	HE60SJSL151K (50V, 150pF, ±10%)	2		
	2818 2040	Ceramic capacitor	HE70SJYF103Z (50V, 0.01μF, ±20%)	2		
	2818 3259	Ceramic capacitor	HE11SJCH221J (50V, 220pF, ±5%)	6		
	2818 8053	Ceramic capacitor	HE50SJSL101K (50V, 100pF, ±20%)	6		
	2819 0280	Ceramic capacitor	HE60SJSL181K (50V, 180pF, ±20%)	2	✓	✓

Note: ☆ - New parts
Q'ty - Quantity used per unit

Rank A: Essential
B: Stock recommended
C: Others
X: No stock recommended

CZ-1 Parts List

Item	Code No.	Part Name	Specification	Q'ty	Price Code	Rank
☆	0002 9284	Mylar capacitor	AMZ123K50 (50V, 0.012μF, ±10%)	4	N/A	X
	2830 8024	Mylar capacitor	AMZ102K50 (50V, 1000pF, ±10%)	8		
	2830 8032	Mylar capacitor	AMZ-103K50 (50V, 0.01μF, ±20%)	1		
	2830 8075	Mylar capacitor	AM-222K50 (50V, 2200pF, ±20%)	2		
	2830 8172	Mylar capacitor	AMZ-183K-50 (50V, 0.018μF, ±20%)	1		
	2830 8181	Mylar capacitor	AMZ-822K50 (50V, 8200pF, ±20%)	3		
	2830 8881	Mylar capacitor	AMZ-123K50 (50V, 0.012μF, ±20%)	4	✓	✓
	3500 3428	Pin ass'y 9P	IL-G-9P-S3T2-E	1	AC	X
☆	3501 0084	Connector :4P	IL-14P-22-M154	1	-	X
	3841 0881	Low pass filter	LPF-M152-17K	2	AE	B
(3) M5154-MA3M PCB ASS'Y						
	2110 3753	Bipolar IC	SN74LS04N	1	AF	A
	222090 15	Transistor	2SC1740	1	AD	A
	22303251	Transistor	2SD400	1	AD	A
	23002016	Diode	1SS254T	1	AA	C
☆	3025 0667	Capacitor, EMI Filter	DST308-568222M (50V, 2200pF, ±20%)	2	AC	B
☆	3025 0793	Capacitor, EMI Filter	DST308-56FZ103Z (50V, 0.01μF, ±80%)	1	AC	B
	2400 5062	Photo coupler	PC900	1	AH	A
	2860 1081	Three polarity capacitor	DS310-56D223S (50V, 0.022μF, ±20%)	2	N/A	X
	3020 2147	Ferrite beads	EL02PN2-R62	4	AB	X
	0002 8723	Carbon film resistor	R-20-100-J (1/5W, 10Kohm, ±5%)	1	N/A	X
	0002 8724	Carbon film resistor	R-20-22-J (1/5W, 22ohm, ±5%)	8		
	0002 8779	Carbon film resistor	R-20-10K-J (1/5W, 10Kohm, ±5%)	1		

Note: ☆ - New parts
Q'ty - Quantity used per unit

Rank A: Essential
B: Stock recommended
C: Others
X: No stock recommended

CZ-1 Parts List

Item	Code No.	Part Name	Specification	Q'ty	Price Code	Rank
	0002 9012	Carbon film resistor	R-20-33-J (1/5W, 33ohm, ±5%)	1	N/A	X
	0002 9018	Carbon film resistor	R-20-270-J (1/5W, 270ohm, ±5%)	1		
	0002 9058	Carbon film resistor	R-20-10-J (1/5W, 10ohm, ±5%)	1		
	0002 8888	Electrolytic capacitor	6.3RE2-100 (6.3V, 100μF, ±20%)	2		
	2807 1248	Electrolytic capacitor	16RE2-47 (16V, 47μF, ±20%)	1		
	2807 1256	Electrolytic capacitor	50RE2-4R7 (50V, 4.7μF, ±20%)	1		
	2818 6053	Ceramic capacitor	HE50SJSL101K (50V, 100pF, ±10%)	2		
	2830 6083	Mylar capacitor	AMZ-223K50 (50V, 0.022μF, ±10%)	1		✓
	3420 2338	Slide switch (protect)	SSY322	1	AE	B
	3500 3991	Pinass'y 2P	IL-G-2P-S3T2-E	1	AA	X
☆	3501 0091	Connector 6P	IL-6P-74-M154	1	-	X
	3812 0541	Din jack MIDI	TCS4850-01-1211	3	AE	X
	3841 1217	Booster	EL-M172A	1	AK	X
(4) M5154-AS1M PCB ASS'Y						
☆	212:0013	Monolithic IC	BA4658CA (NJM4558DD)	1	AD	A
☆	2114 0021	Monolithic IC	LA8462D	2	AE	A
☆	2114 0028	Monolithic IC (VCA)	M52411	1	AH	A
	2120 8571	IC (Power Amp.)	LA4170	1	AF	A
	22209035	Transistor	2SC1740	2	AD	A
	23010291	Diode	1SS270	1	AA	C
	23103176	Zener diode	RD10E	1	AA	A
	2760 2177	Semi fixed resistor	V8K4-11B10K	2	AB	B
	2760 2215	Semi fixed resistor	V8K4-11B20K	1	AB	B
	3020 2147	Ferrite beads	BL02RN2-R62	8	AB	X
☆	3025 0063	Capacitor, EMI Filter	DST308-56FZ103Z (50V, 0.01μF, +80% -20%)	4	AC	B
☆	3122 0028	Relay	G2VN-237PL	1	AK	B
	0002 8728	Carbon film resistor	R-20-1K-J (1/5W, 1Kohm, ±5%)	6	N/A	C

Note: ☆ - New parts
Q'ty - Quantity used per unit

Rank A: Essential
B: Stock recommended
C: Others
X: No stock recommended

C7-1 Parts List

Item	Code No.	Part Name	Specification	Q'ty	Price Code	Rank
	0002 8728	Carbon film resistor	R-20-4.7K-J (1/5W, 4.7Kohm, ±5%)	1	N/A	X
	0002 8729	Carbon film resistor	R-20-10K-J (1/5W, 10Kohm, ±5%)	15		
	0002 8730	Carbon film resistor	R-20-33K-J (1/5W, 33Kohm, ±5%)	1		
	0002 8731	Carbon film resistor	R-20-47K-J (1/5W, 47Kohm, ±5%)	2		
	0002 8733	Carbon film resistor	R-20-100K-J (1/5W, 100Kohm, ±5%)	2		
	0002 8738	Carbon film resistor	R-20-39K-J (1/5W, 39Kohm, ±5%)	1		
	0002 8946	Carbon film resistor	R-20-3.3K-J (1/5W, 3.3Kohm, ±5%)	2		
	0002 8947	Carbon film resistor	R-20-68K-J (1/5W, 68Kohm, ±5%)	1		
	0002 8950	Carbon film resistor	R-20-680-J (1/5W, 680ohm, ±5%)	1		
	0002 8951	Carbon film resistor	R-20-12K-J (1/5W, 12Kohm, ±5%)	4		
	0002 8956	Carbon film resistor	R-20-22K-J (1/5W, 22Kohm, ±5%)	2		
	0002 8957	Carbon film resistor	R-20-56K-J (1/5W, 56Kohm, ±5%)	3		
	0002 8961	Carbon film resistor	R-20-390K-J (1/5W, 390Kohm, ±5%)	2		
	0002 8962	Carbon film resistor	R-20-6.8K-J (1/5W, 6.8Kohm, ±5%)	2		
	0002 9002	Carbon film resistor	R-20-15K-J (1/5W, 15Kohm, ±5%)	4		
	0002 9017	Carbon film resistor	R-20-2.7K-J (1/5W, 2.7Kohm, ±5%)	2		
☆	0002 9081	Carbon film resistor	R-20-30K-J (1/5W, 30Kohm, ±5%)	2		
	0002 9256	Carbon film resistor	R-20-29-J (1.5W, 39ohm, ±5%)	2		
	0002 8718	Electrolytic capacitor	16RE2-330 (16V, 330μF, ±20%)	2		
	0002 8887	Electrolytic capacitor	16RE2-100 (16V, 100μF, ±20%)	2		
	0002 9063	Electrolytic capacitor	16RE2-10 (16V, 10μF, ±20%)	3		
☆	2800 9098	Electrolytic capacitor	6.3RE2-1000-S1 (6.3V, 1000μF, ±20%)	1		
	2804 9013	Electrolytic capacitor	50RN88P1 (50V, 1μF, ±20%)	8		
	3807 9188	Electrolytic capacitor	16RN88P4R7 (16V, 4.7μF, ±20%)	1		
	2807 9340	Electrolytic capacitor	16RN88P10 (16V, 10μF, ±20%)	2		
	2805 2216	Electrolytic capacitor	16RE2-470-S (16RE, 470μF, ±20%)	3		
	2807 1248	Electrolytic capacitor	16RE2-47 (16V, 47μF, ±20%)	1		
	2818 2040	Ceramic capacitor	HE70SJYF103Z (50V, 0.01μF, +80% -20%)	4		
	2819 0287	Ceramic capacitor	HE80SJSL151K (50V, 150μF, ±10%)	2		
	2830 6032	Mylar capacitor	AMZ-103K50 (50V, 0.01μF, ±20%)	2		
	2830 6041	Mylar capacitor	AMZ-104K50 (50V, 0.1μF, ±20%)	1		
☆	3500 7836	Pin ass'y 6P	IL-G-6P-S3L2-E	1	AC	X
☆	3501 0105	Connector 5P	IL-5P-77-M154	1	-	X

Note: ☆ - New parts
Q'ty - Quantity used per unit

Rank A: Essential
B: Stock recommended
C: Others
X: No stock recommended

CZ-1 Parts List

Item	Code No.	Part Name	Specification	Q'ty	Price Code	Rank
☆	3501 0112	Connector 9P	IL-9P-28-M154	1	-	X
	3612 0584	Jack Lineout	YKB21-5012	2	AD	B
	3612 0592	Jack Headphone	YKB21-5002	1	AD	B
	3612 0831	Jack Foot VR/Sustain	YKB21-5014	2	AC	B
	5430 0107	Nut	YKV11-0095	5	-	X
	6904 0450	Jack holder	M31362-1	1	-	X
(5) M5154-MA4M PCB ASS'Y						
	2111 2194	Bipolar IC	SN74LS138N	2	AN	A
	2111 2496	Bipolar IC	SN74LS174N	5	AK	A
	2184 1014	Bipolar IC	HD74LS154P	1	AH	A
	0002 8726	Carbon film resistor	R-20-1K-J (1/5W, 1Kohm, ±5%)	7	N/A	X
	2860 1069	Capacitor	DS310-56D223S (50V, 0.022μF)	8	N/A	X
☆	3501 0098	Connector 3P	IL-3P-32-M154	1	-	X
☆	3725 0175	PC joiner	PCJ-UV-14-180	1	AG	X
	37250182	PC joiner	PCJ-UV-13-205	1	AG	X
	37210679	PC joiner	PCJ-JPSS-16-135 (16-142)	1	AE	X
☆	37210309	PC joiner	PCJ-JPSS-16-125 (16-130)	2	AD	X
☆	3725 0203	PC joiner	PCJ-JVU-17-158	1	AF	X
	6002 0248	Joiner holder G545	P4260-1	2	-	X
(6) M5154-CN1M PCB ASS'Y						
	2301 0291	Diode	1SS270	30	AA	C
	2320 9811	LED	LN266RPT	31	AB	B
	0002 9016	Carbon film resistor	R-20-390-J (1/5W, 390ohm, ±5%)	31	N/A	X
	3410 1710	Push switch	KHC10302	30	AB	B
*	37211028	PC joiner M154E	PCJ-UV-20-230 (20-330)	1	AH	X
	6215 1340	Joiner holder E92	E41908-2	1	-	X
(7) M5154-CN2M PCB ASS'Y						
	2114 0021	Monolithic IC	LA6462D	1	AE	A
	23010291	Diode	1SS270	38	AA	C
	2320 9811	LED	LN266RPT	30	AB	B

Note: ☆ - New parts
Q'ty - Quantity used per unit

Rank A: Essential
B: Stock recommended
C: Others
X: No stock recommended

CZ-1 Parts List

Item	Code No.	Part Name	Specification	Q'ty	Price Code	Rank
	0002 8723	Carbon film resistor	R-20-100-J (1/5W, 100ohm, ±5%)	1	N/A	X
	0002 8726	Carbon film resistor	R-20-1K-J (1/5W, 1Kohm, ±5%)	2		
	0002 8729	Carbon film resistor	R-20-10K-J (1/5W, 10Kohm, ±5%)	1		
	0002 8734	Carbon film resistor	R-20-150K-J (1/5W, 150Kohm, ±5%)	1		
	0002 9016	Carbon film resistor	R-20-390-J (1/5W, 390ohm, ±5%)	30		
	0002 9002	Carbon film resistor	R-20-15K-J (1/5W, 15Kohm, ±5%)	5		
	0002 8963	Carbon film resistor	R-20-18K-J (1/5W, 18Kohm, ±5%)	2		
	2770 9605	VR Main	EWA-NF0X05B14	1	AE	B
	2770 9761	Slide VR Stereo Chorus	EWA-NA1X05B54	1	AE	B
	3410 1710	Push switch	KHC10902	36	AB	B
	3501 0128	8P Connector M154B	IL-8P-21-M154	1	-	X
	3501 0133	8P Connector M154A	IL-8P-30-M154	1	-	X
(8) M5154-CN3M PCB ASS'Y						
	2301 0291	Diode	1SS270	4	AA	C
	3410 1710	Push switch	KHC10902	4	AB	B
	37210636	PC joiner M154J	PCJ-JPSS-15-35 (15-32)	2	AB	X
(9) M5177-KEY BOARD PCB ASS'Y						
	2004 0815	LSI (Key touch control LSI)	MSM8200GS-1L	1	BE	A
	2300 1021	Diode	1S2075K	94	AA	C
	2301 0291	Diode	1SS270	28	AA	C
	0002 9262	Carbon film resistor	R-20-100K-G (1/5W, 100Kohm, ±2%)	8	N/A	X
	0002 8733	Carbon film resistor	R-20-100-J (1/5W, 100ohm, ±5%)	1		
	0002 8726	Carbon film resistor	R-20-1K-J (1/5W, 1Kohm, ±5%)	1		
	0002 8957	Carbon film resistor	R-20-56K-J (1/5W, 56Kohm, ±5%)	2		
	0002 9063	Electrolytic capacitor	16RE2-10 (16V, 10μF, ±20%)	2		
	2818 2040	Ceramic capacitor	HE70SJYF103Z (50V, 10000pF, +80% -20%)	2		
	0002 9263	Mylar capacitor	AMZ-104J50 (50V, 100000pF, ±5%)	8		
	3721 0032	PC joiner M71A	PCJ-UV-19-90	1	AF	X
	3721 0041	PC joiner M71B	PCJ-JVU-16-22	2	AB	X

Note: ☆ - New parts
Q'ty - Quantity used per unit

Rank A: Essential
B: Stock recommended
C: Others
X: No stock recommended

CZ-1 Parts List

Item	Code No.	Part Name	Specification	Q'ty	Price Code	Rank
	8215 1340	Joiner holder E92	E41909-2	1	-	X
	6905 6980	Parallel wire M177KY	M42591-1	1	-	X
	43072420	Blank PCB M571-KY1M	M2822A-1	1	AQ	X
	43072440	Blank PCB M571-KY3M	M2823A-1	1	AQ	X
	4307 4290	Blank PCB M5177-KY2M	M21246-1	1	AN	X
(10) POWER SUPPLY ASS'Y						
	3012 0007	Transformer	TE-154-1M1	1	BB	B
	6901 6470	Transformer fixing plate	M4887-1	1	-	X
	36001160	Voltage selector	ESE-371	1	AE	C
(11) M5154-PS1 PCB ASS'Y						
	2818 2601	Ceramic capacitor	DE7150FZ103PVA1	2	N/A	X
	3020 2238	Line filter	PLA8021A	1	A-	C
	3510 2680	Pin ass'y 2P	5277-02A	1	-	X
	36402331	Fuse holder	UF-0033"1	2	AA	X
	3670 1181	Receptacle	NC-174	1	AD	C
	6901 5580	Receptacle fixing plate	M4850-1	1	-	X
(12) M5154-PS2M PCB ASS'Y						
	21208647	Monolithic IC	NJM78M15A (UA78M15H)	1	AG	A
	22105078	Transistor	2S8632	2	AD	A
	22303023	Transistor	2SD313	2	AD	A
	22009010	Transistor	2SA933	1	AD	A
	22209035	Transistor	2SC1740	4	AD	A
	2301 0097	Diode	1S2473	1	AA	C
	23103168	Zener diode	RD8.2E	1	AA	B
	23103273	Zener diode	RD5.6E	1	AA	B
	23103249	Zener diode	RD8.2E	2	AB	B
	23102323	Zener diode	RD18E	1	AA	B
	23102455	Zener diode	RD18E	1	AA	B
	23301075	Diode stack	S4VB10-4009 (S4VB10)	1	AE	C
	23009102	Diode stack	S2VB10-4009 (S2VB10)	1	AD	C
	2605 0083	Metal film resistor	CRH100FH11-J-0.47	2	N/A	X
	36302534	Fuse	0.5A(S)	2	AC	A
	36302526	Fuse	2.0A(S)	1	AC	A
	2605 0070	Metal film resistor	CRH100FH11-J-100	1	N/A	X

Note: ☆ - New parts

Q'ty - Quantity used per unit

Rank A: Essential

B: Stock recommended

C: Others

X: No stock recommended

CZ-1 Parts List

Item	Code No.	Part Name	Specification	Q'ty	Price Code	Rank
	2600 9715	Carbon film resistor	R-25-100K-J (1/4W, 100Kohm, ±5%)	1	N/A	X
	2600 5311	Carbon film resistor	R-25-1.5K-J (1/4W, 1.5Kohm, ±5%)	1		
	2600 5515	Carbon film resistor	R-25-1.8K-J (1/4W, 1.8Kohm, ±5%)	1		
	2600 2516	Carbon film resistor	R-25-100-J (1/4W, 100ohm, ±5%)	2		
	2601 5715	Carbon film resistor	R-25-4.7-J(1/4W, 4.7ohm, ±5%)	1		
	2600 4314	Carbon film resistor	R-25-560-J(1/4W, 560ohm ±5%)	2		
	2600 5710	Carbon film resistor	R-25-2.2K-J(1/4W, 2.2Kohm, ±5%)	1		
	2600 5116	Carbon film resistor	R-25-1.2K-J(1/4W, 1.2Kohm, ±5%)	1		
	2600 1111	Carbon film resistor	R-25-27-J(1/4W, 27ohm, ±5%)	1		
	2800 9196	Electrolytic capacitor	16LP3-4700 (16V, 4,700μF, ±20%)	1		
	2805 2210	Electrolytic capacitor	16RE2-470-S1(16V, 470μF, ±20%)	2		
	2805 2383	Electrolytic capacitor	35RE2-1000-S1 (35V, 1000μF, ±20%)	2		
	0002 9259	Electrolytic capacitor	25RE2-220 (25V, 220μF, ±20%)	1		
	0002 8886	Electrolytic capacitor	50RE2-1 (50V, 1μF, ±20%)	1		
	0002 8720	Electrolytic capacitor	6.3RE2-470 (6.3V, 470μF, ±20%)	3		
	2805 2180	Electrolytic capacitor	10RE2-220 (10V, 220μF, ±20%)	3		
	3500 3355	Pin ass'y 3P	IL-G-3P-S3T2-E	1	AA	X
	3500 7610	Pin ass'y 5P	IL-G-5P-S3T2-E	1	AA	X
	3501 0119	10P Connector M154	IL-10P-81-M154	1	-	X
	36402331	Fuse holder	UF-0033#01	6	AA	X
	6904 6382	Heat sink 153	M421918-1	1	-	X
	6907 4370	Wire ass'y	M42750*1	1	-	X
	6910 9160	Heat sink	M41852-1	1	-	X
(13) UPPER CASE UNIT						
1	6901 3860	Sponge J	M4630-7	1	-	X
2	6904 6140	DIN jack holder 153	M31619	1	-	X
☆ 3	6907 4621	Upper case sub ass'y	M32143A*1	1	BG	C
☆ 4	6907 4631	Upper panel sub ass'y	M1972A*1	1	BT	C
☆ 5	6907 4640	PCB cover R	M32173-1	1	-	X
☆ 6	6907 4650	PCB cover L	M32174-1	1	-	X

Note: ☆ - New parts
Q'ty - Quantity used per unit

Rank A: Essential
B: Stock recommended
C: Others
X: No stock recommended

CZ-1 Parts List

Item	Code No.	Part Name	Specification	Q'ty	Price Code	Rank
(14) PACK CASE ASS'Y						
9	6904 5950	Pack case sub ass'y	M31651*1	1	-	C
10	6904 6090	Pack lower case	M31621-1	1	-	C
11	6904 6100	Pack house holder	M42129-1	1	-	X
12	69115310	RAM pack cover	M31489-1	1	AC	C
13	6911 5320	Pack cover shaft	M41948-1	1	-	X
14	6911 5330	Spring	M41947-1	1	AA	C
15	0002 8824	PE washer	M41951A-1	2	-	C
16	3510 6481	Connector	PS30PE-S4LT1-PN1	1	AP	C
☆17	3725 0224	PC joiner	SMCD-15-180	2	AF	C
☆18	4307 5450	PCB M5154-IF	M42747-1	1	AC	C
19	6276 8118	Jumper wire	A3732B-13	2	-	C
(15) UPPER PANEL SUB ASS'Y						
20	6902 6250	Slide VR blind	M41215	2	-	X
☆21	6905 2120	VR knob	M31622-2	1	AC	B
☆22	6907 4770	Key top set 154-1	M32147*1 (16pcs)	1	AH	C
☆23	6907 4780	Key top 154-2	M32148*2 (16pcs)	1	AH	C
☆24	6907 4790	Key top set 154-3	M32149*3 (2pcs)	1	AH	C
☆25	6907 4800	Key top set 154-4	M32150*1 (4pcs)	1	AH	C
☆26	6907 4810	Key top set 154-5	M32151*1 (3pcs)	1	AH	C
☆27	6907 4820	Key top set 154-6	M32152*1 (4pcs)	1	AH	C
☆28	6907 4830	Key top set 154-7	M32153*1 (17pcs)	1	AH	C
☆29	6907 4840	Key top set 154-8	M32154*1 (8pcs)	1	AH	C
(16) LCD UNIT						
☆30	3301 0014	EL	KA137A	1	AU	B
☆31	3335 0014	LCD ass'y	LM550LT (includes item 30)	1	BQ	A
☆32	3501 0147	14P connector M154B	IL-14P-28-M154	1	-	X
☆33	6907 4740	LCD holder	M32021-1	1	AF	X
☆34	6910 1730	LCD tape	M4696-1	1	-	X
(17) POWER SWITCH ASS'Y						
35	3440 5255	Power switch	SDJ1S	1	AI	B
36	3501 0140	2P connector M154C	5265-2P-22-M154	1	-	X

Note: ☆ - New parts
Q'ty - Quantity used per unit

Rank A: Essential
B: Stock recommended
C: Others
X: No stock recommended

CZ-1 Parts List

Item	Code No.	Part Name	Specification	Q'ty	Price Code	Rank
(18) SIDE PLATE R ASS'Y						
☆37	8907 4600	Side plate R sub ass'y	M32140*1	1	AW	X
38	8430 0115	Bit insert nut	FB-4001	2	-	X
(19) LOWER CASE ASS'Y						
40	8902 1890	Insulator sheet	M41197-1	1	-	X
41	6910 4230	LCD holder	M4880-1	2	-	X
☆42	6907 4590	Lower case sub ass'y	M21364*1	1	BW	C
(20) SIDE PLATE L ASS'Y						
☆43	6907 4700	Side plate L sub ass'y	M32145*1	1	AX	X
46	2770 6843	Volume	VM10W520A-50KB	2	AH	B
☆47	3501 0154	4P connector M154A	IL-4P-118-M154	1	-	X
48	6904 0420	Bender spring	M14737-1	1	AB	X
49	6904 6110	Bender knob	M31620-1	2	AD	C
50	6904 6120	Bender chassis 153	M42128-1	2	-	X
51	6904 7020	Felt 153	M42360-1	2	-	X
52	6911 5250	Bender chassis B	M41946	2	-	X
(21) KEY PLATE SET						
**KEYS DO NOT INCLUDED WEIGHTS						
53	6903 7710	White key CF	M31269-1	10	AF	C
54	6903 7720	White key BE	M31271-1	10	AF	C
55	6903 7730	White key D	M31270-1	5	AF	C
56	6903 7740	White key G	M31272-1	5	AF	C
57	6903 7750	White key A	M31273-1	5	AF	C
58	6903 7760	White key S	M31274-1	1	AF	C
59	6903 7770	Black key	M31275-1	25	AF	C
60	6903 7780	KB spring TR	M41630-1	25	AA	X
61	6903 9880	KB spring TR	M41630-2	36	AA	X
62	6904 0551	Key stopper	M31279A-1	1	-	X
* 63	6904 6470	Weight WN	M42334-1	36	AB	X
* 64	6904 6480	Weight BN	M42335-1	25	AB	X
65	6907 4720	Upper case stopper	M32023-1	1	-	C

Note: ☆ - New parts
Q'ty - Quantity used per unit

Rank A: Essential
B: Stock recommended
C: Others
X: No stock recommended

C7-1 Parts List

Item	Code No.	Part Name	Specification	Q'ty	Price Code	Rank
☆66	3501 0161	2P connector M154A	IL-2P-60-M154	1	-	X
☆67	6907 4861	Element AFS	M32088-1	2	AQ	X
☆68	6907 4871	Element AFS	M32088-2	1	AK	X
☆69	6907 4881	Housing AFS	M32089-1	1	AH	X
☆70	6907 4891	Electrode plate	M42685-1	2	AH	X
☆71	6907 4901	Damper	M42686-1	1	AF	X
72	6903 7661	Rubber switch E	M31276A-1	4	AF	B
73	6903 7671	Rubber switch F	M31277A-1	1	AF	B
74	6903 7680	KB guide A	M31317-1	4	-	X
76	6903 7890	KB guide B	M31318-1	1	-	X
77	6904 0580	Damping tape A	M31460-1	2	-	X
78	6904 0590	Damping tape B	M31461-1	1	-	X
79	6904 0600	Black seal	M31462-1	5	-	X
☆80	6903 7520	KB shassis	M2870D*1	1	-	X

Note: ☆ - New parts
 Q'ty - Quantity used per unit

Rank A: Essential
 B: Stock recommended
 C: Others
 X: No stock recommended

Other Parts

37002763	Power Cord	UC901-001	1	AO	X
69046430	Dust Cover	M31736-1	1	AK	X
37009491	Plug Cord Set	6.3MPP-L330H-9	1	AN	X

