

SERVICE MANUAL & PARTS LIST

(without price)

CZ-5000 DIGITAL SYNTHESIZER

JUNE 1985

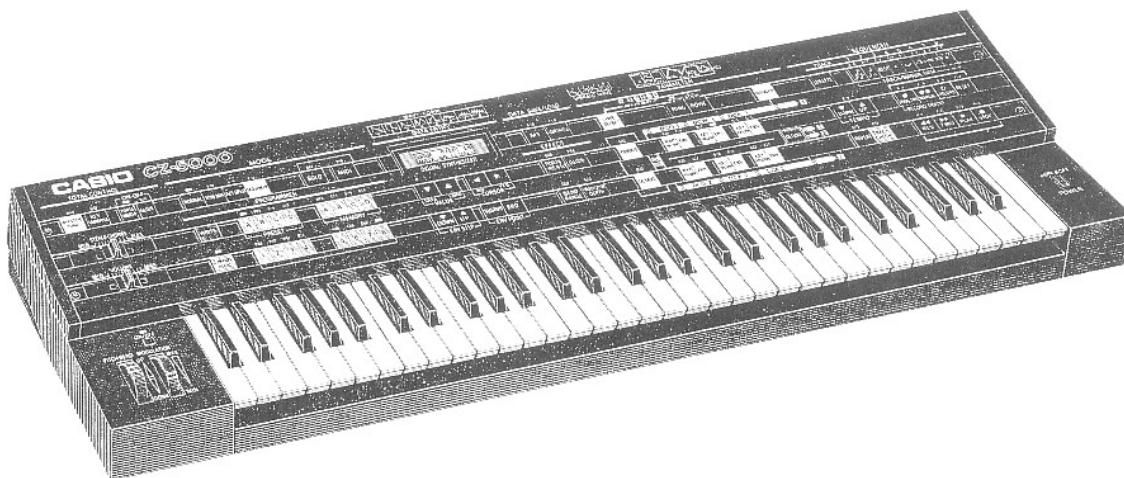

CZ 5000

CASIO®

CAUTION:

When the connector ○ (from the batteries) is disconnected, all the sound data in the Memory Bank are cleared. When this happens, initialize the unit by the following procedures.

1. Turn the power switch off and press INITIALIZE button.
2. Turn the power switch on, then the display indicates;

```
SYSTEM ALL  
INITIALIZE(Y/N)?
```

3. While pushing INITIALIZE button, press YES button on the data entry section of the panel. All the Memory Bank data are initialized, then the display shows:

```
SYSTEM  
INITIALIZED !!
```

CONTENTS

1.	SCHEMATIC DIAGRAM	1
1-1.	Main PCB (A) M5153-MA1M	1
1-2.	Main PCB (B) M5153-MA1M	2
1-3.	Stereo Chorus Circuit PCB M5153-MA2M	3
1-4.	MIDI and MT Control PCB M5153-MA3M	4
1-5.	Amp. Block PCB M5153-AS1M	5
1-6.	LED Drive Circuit PCB M5153-MA4M	6
1-7.	Panel Block (A) PCB M5153-CN1M	7
1-8.	Panel Block (B) PCB M5153-CN2M	8
1-9.	Modulation Switch PCB M5153-CN3	9
1-10.	Power Supply Circuit PCB M5153-PS1, PS2	10
1-11.	Keyboard (1) PCB M416-KY1	11
1-12.	Keyboard (2) PCB M416-KY2	12
1-13.	Keyboard PCB M425-KY3	13
2.	WIRING DIAGRAM	14
3.	PCB VIEW & MAJOR CHECKPOINT	16
3-1.	PCB M5153-MA1M	16
3-2.	PCB M5153-MA2M	17
4.	MAJOR WAVEFORMS	18
5.	BLOCK DIAGRAM	21
6.	DIGITAL CIRCUIT BLOCK DIAGRAM	22
7.	MAIN CPU (μ PD7811-180)	23
8.	SUB-CPU (μ PD7811-204)	24
9.	MAIN RAMS & ROM ACCESS	26
10.	SUB-RAMS & ROM ACCESS	27
11.	ACCESS TO MUSIC LSI	28
12.	CPU INTERFACE (MB64H173)	29
12-1.	Function of Each Block	30
12-2.	Data Transfer Procedures	31
13.	KEY MATRIX	35
14.	LED DRIVING CIRCUITS	36
15.	ANALOG CIRCUIT BLOCK DIAGRAM	38
16.	MUSIC LSI (μ PD933)	39
17.	DAC (Digital to Analog Converter)	40
18.	EXPANDER CIRCUIT	41
19.	SAMPLE & HOLD CIRCUIT	43

20.	STEREO CHORUS CIRCUIT	44
	20-1. Three-Phase LFO (Low Frequency Oscillator)	45
	20-2. VCO (Voltage Controlled Oscillator)	46
	20-3. BBD (Bucket Brigade Device)	47
	20-4. Compressor and Expander Circuits	48
21.	VOLUME CONTROL CIRCUIT	49
22.	RESET CIRCUIT	50
23.	MIDI & MT INTERFACE CIRCUITS	51
	23-1. MIDI Interface Circuit	51
	23-2. MT Interface Circuit	52
24.	ADJUSTMENT	53
	24-1. DAC Offset Voltage	53
	24-2. Volume Adjustment	53
	PARTS LIST	55
	EXPLODED VIEW	69

1. SCHEMATIC DIAGRAM

1-1. Main PCB (A) M5153-MA1M

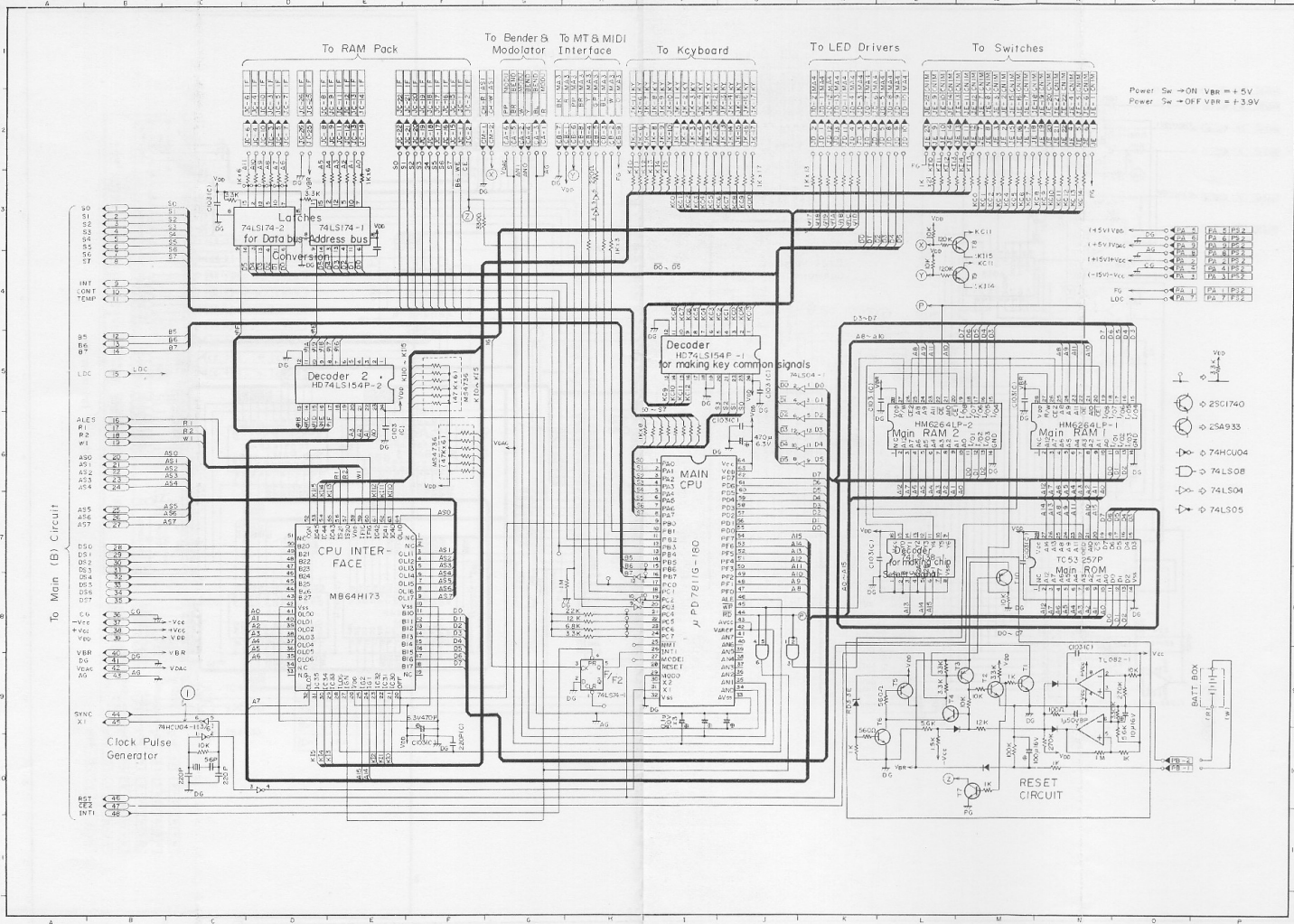

1-3. Stereo Chorus Circuit PCB M5153-MA2M

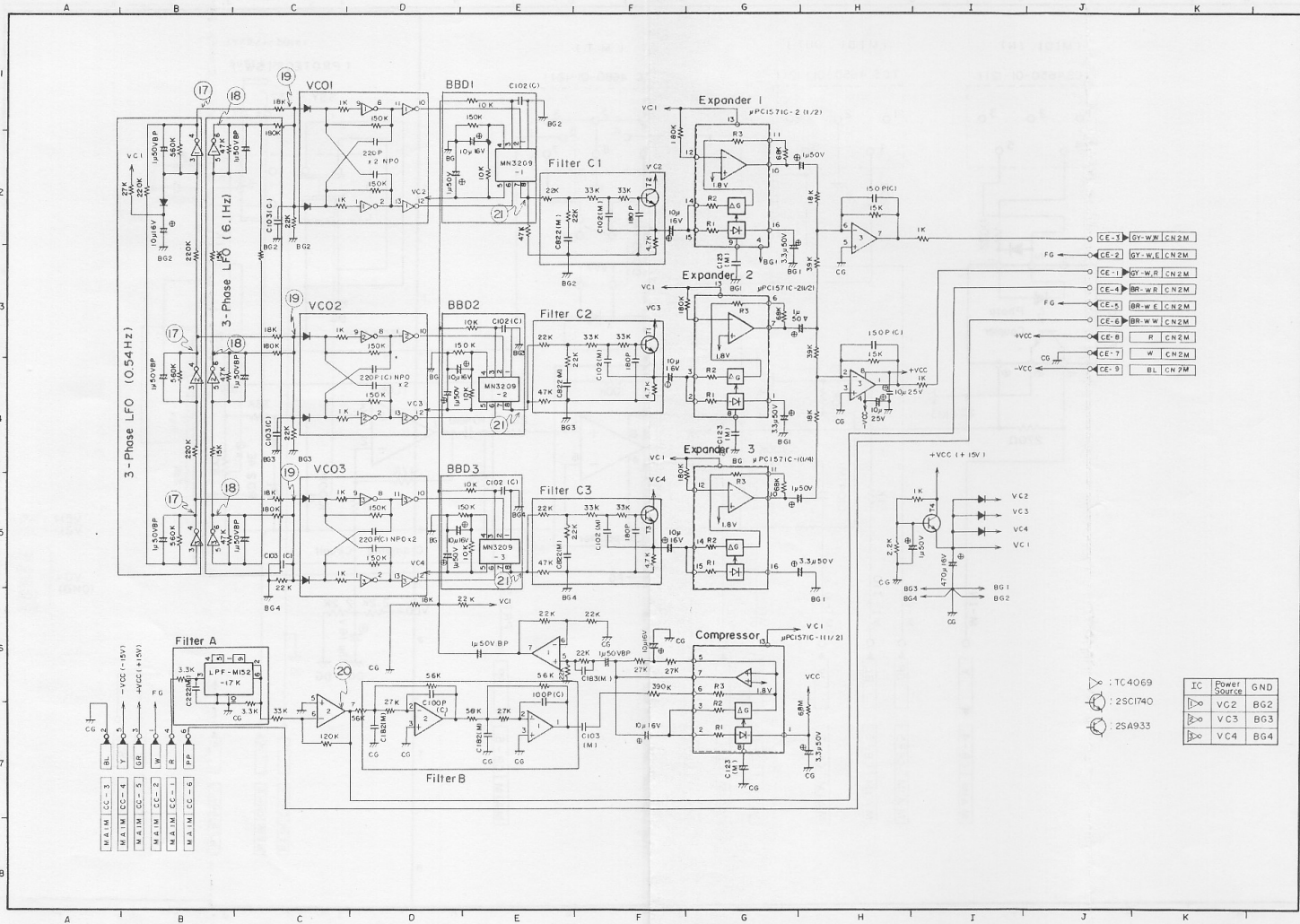

1-4. MIDI and MT Control PCB M5153-MA3M

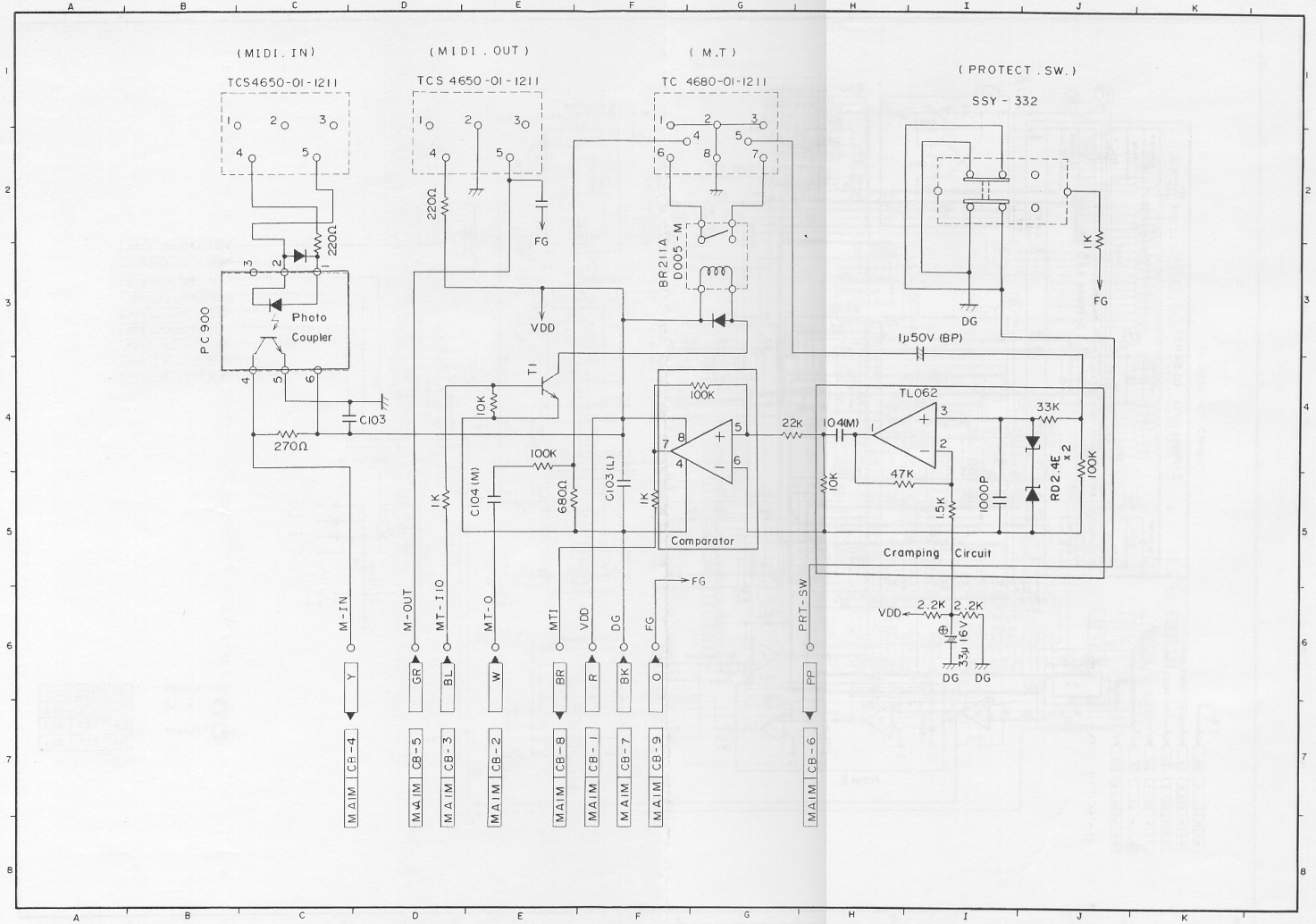

1-5. Amp. Block PCB M5153-AS1M

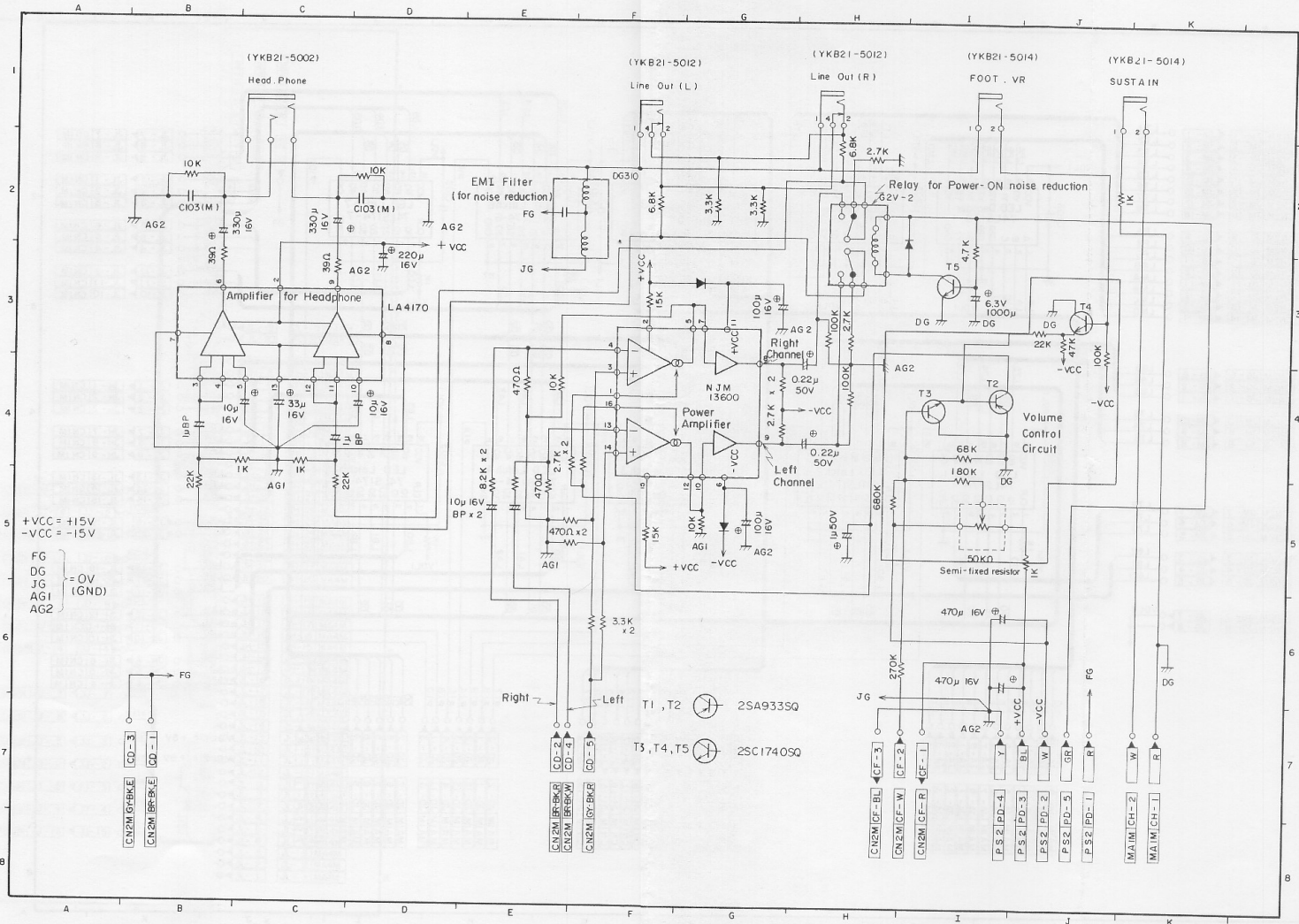

1-6. LED Drive Circuit PCB M5153-MA4M

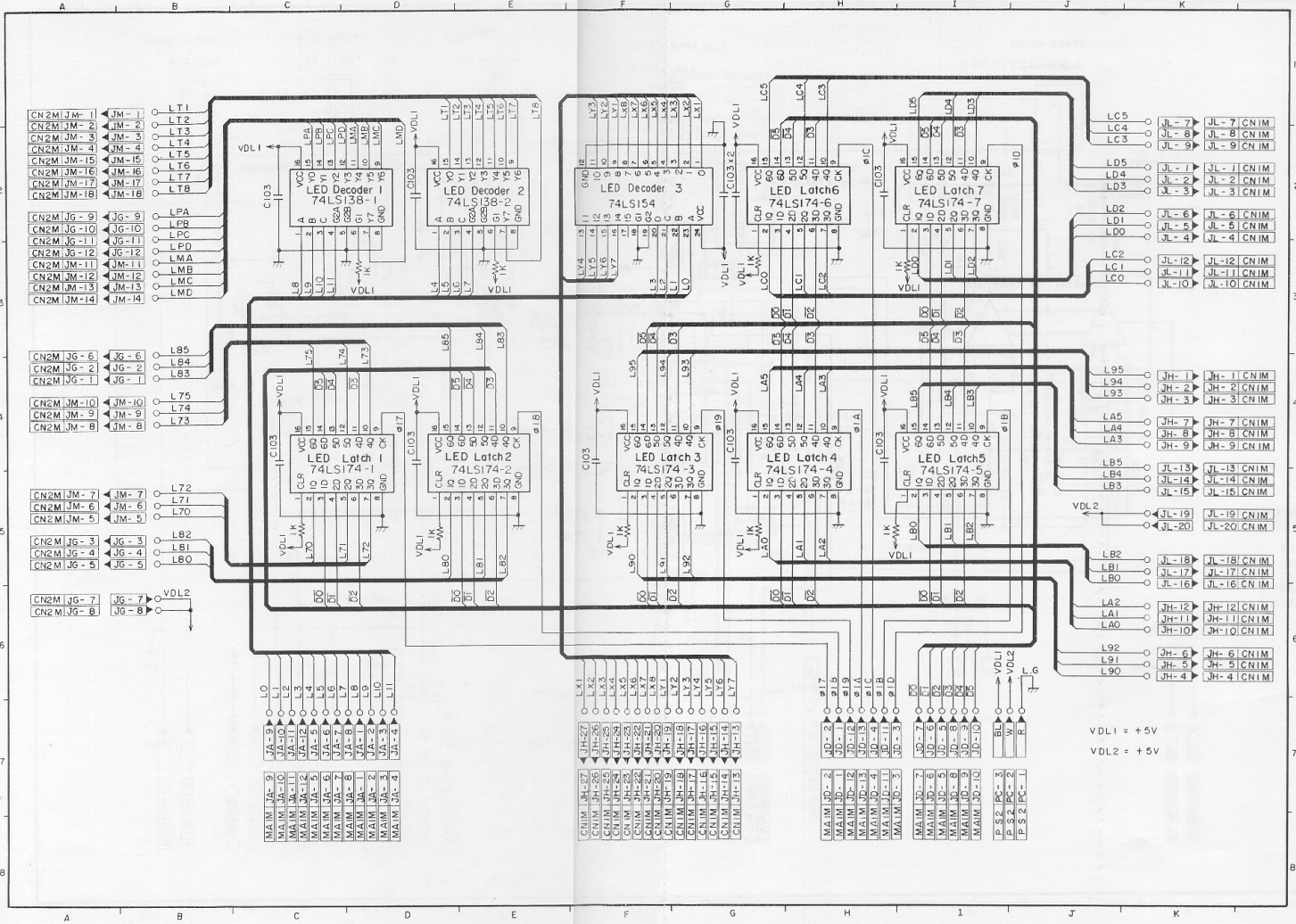

1-7. Panel Block (A) PCB M5153-CN1M

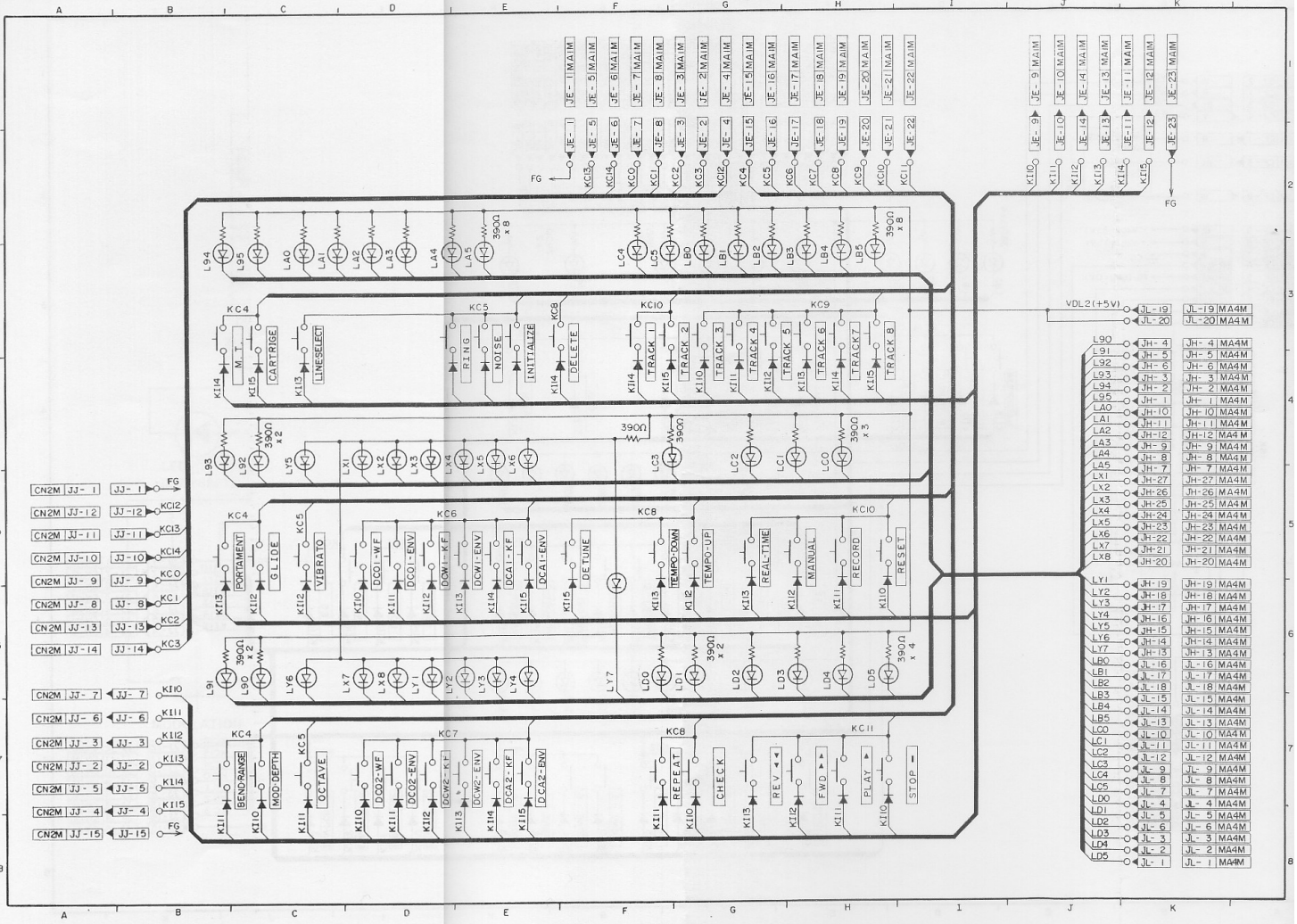

1-9. Modulation Switch PCB M5153-CN3

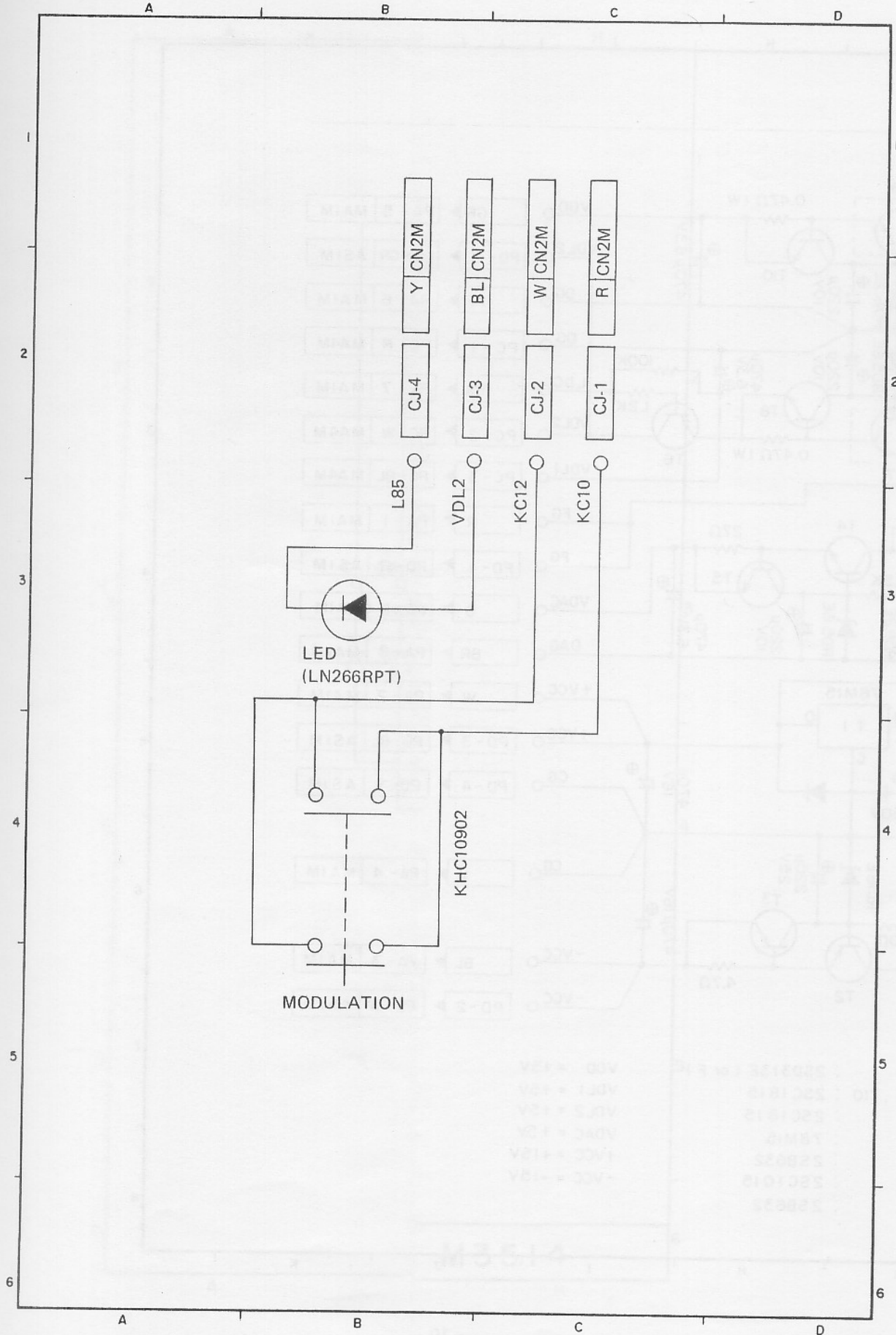

1-10. Power Supply Circuit PCB M5153-PS1, PS2

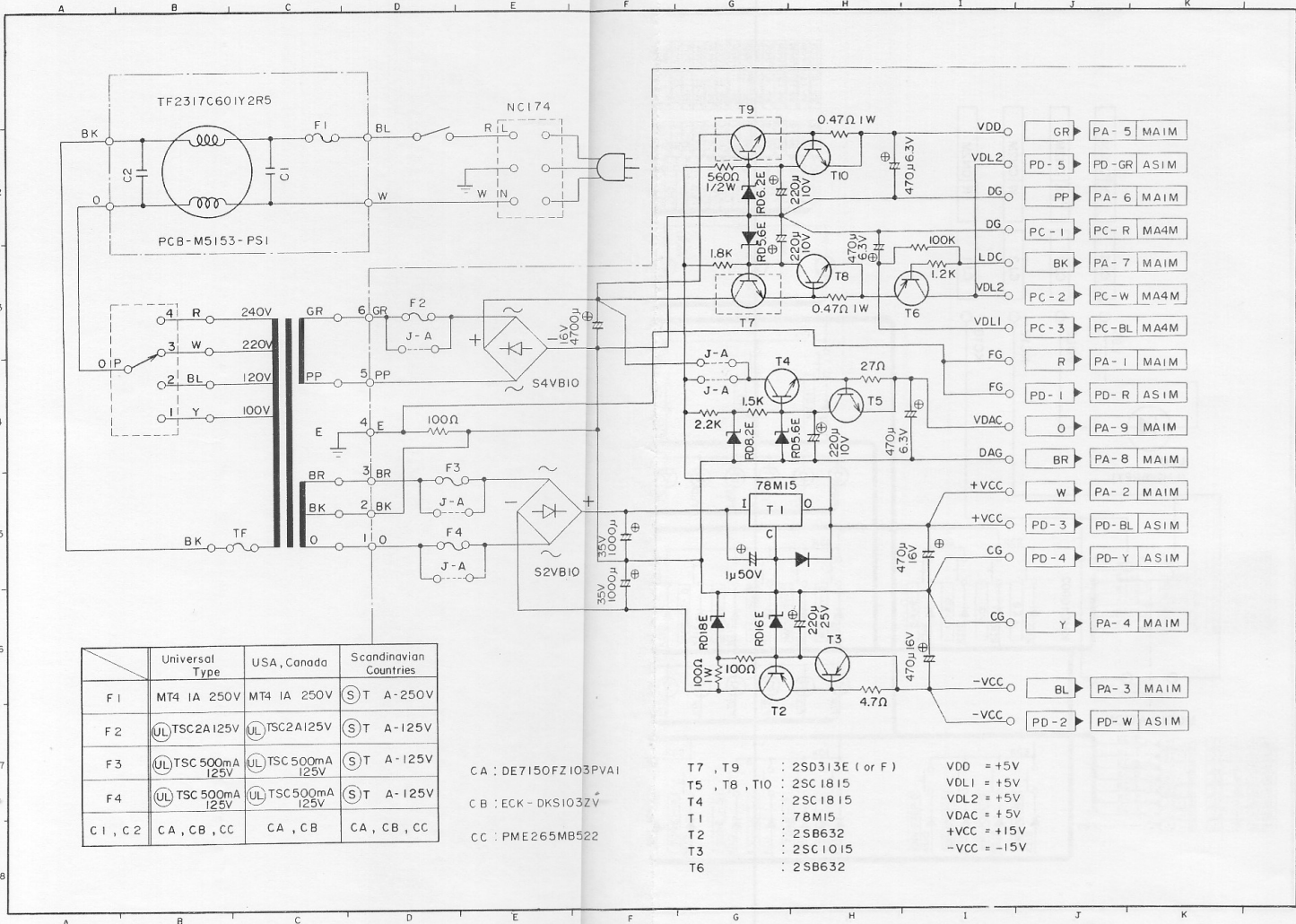

	Universal Type	USA, Canada	Scandinavian Countries
F 1	MT4 IA 250V	MT4 IA 250V	S T A-250V
F 2	UL TSC2A125V	UL TSC2A125V	S T A-125V
F 3	UL TSC 500mA 125V	UL TSC 500mA 125V	S T A-125V
F 4	UL TSC 500mA 125V	UL TSC 500mA 125V	S T A-125V
C 1, C 2	CA, CB, CC	CA, CB	CA, CB, CC

CA : DE7150FZ103PVA1
 CB : ECK - DKS103ZV
 CC : PME265MB522

T 7, T 9 : 2SD313E (or F)
 T 5, T 8, T 10 : 2SC 1815
 T 4 : 2SC 1815
 T 1 : 78M15
 T 2 : 2SB632
 T 3 : 2SC 1015
 T 6 : 2SB632

VDD = +5V
 VDL1 = +5V
 VDL2 = +5V
 VDAC = +5V
 +VCC = +15V
 -VCC = -15V

1-11. Keyboard (1) PCB M416-KY1

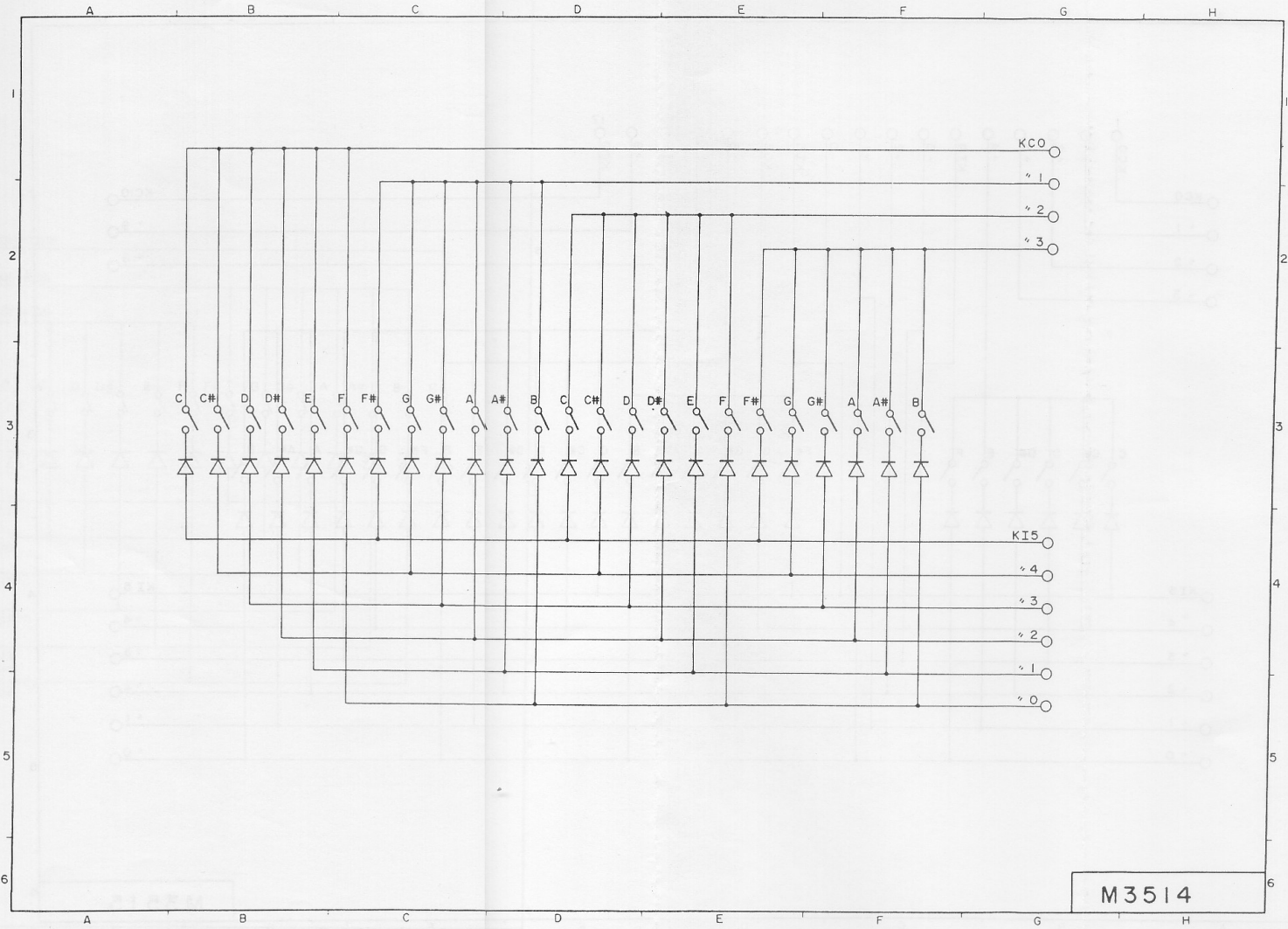

M3514

1-12. Keyboard (2) PCB M416-KY2

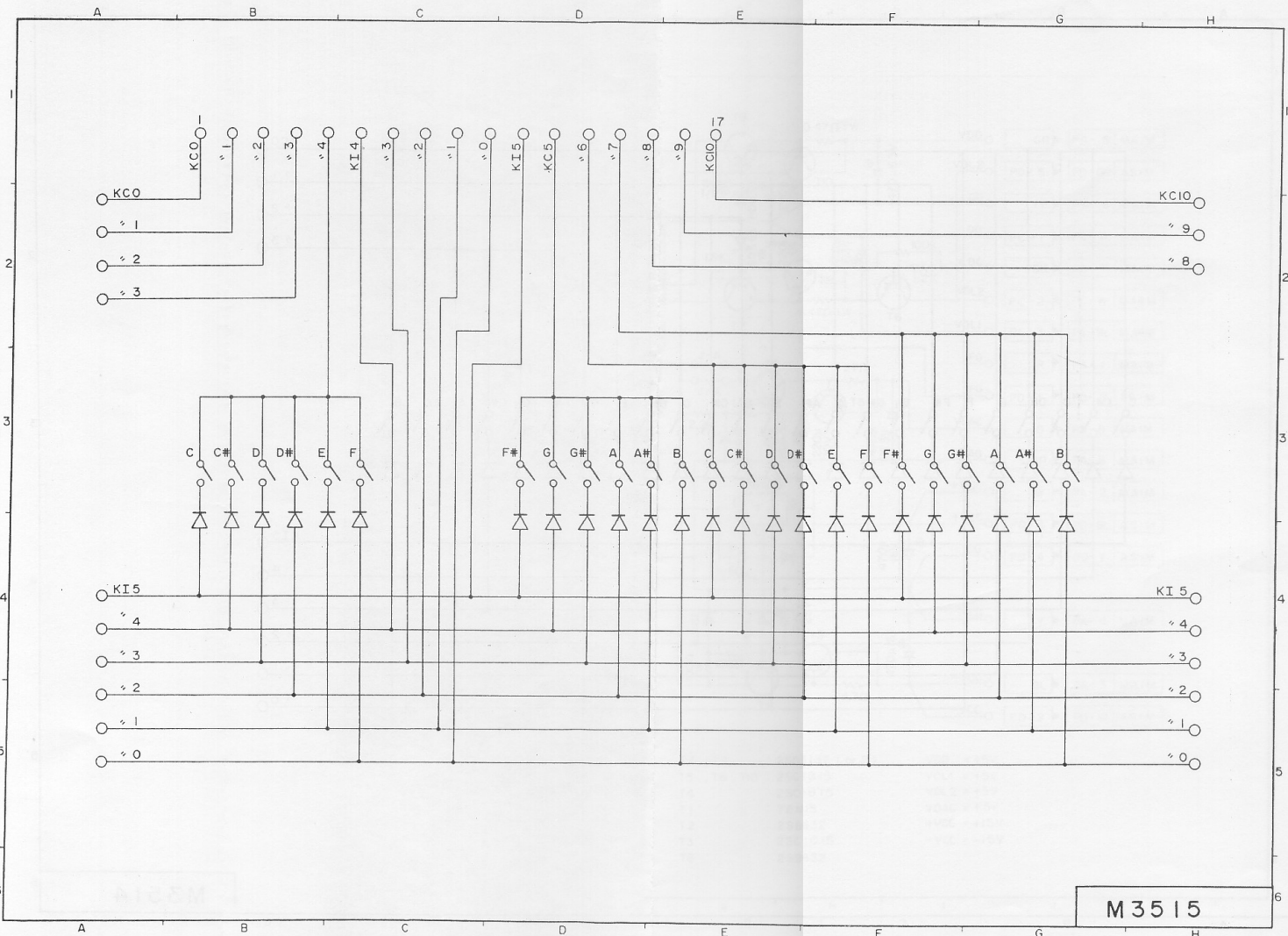

1-13. Keyboard PCB M425-KY3

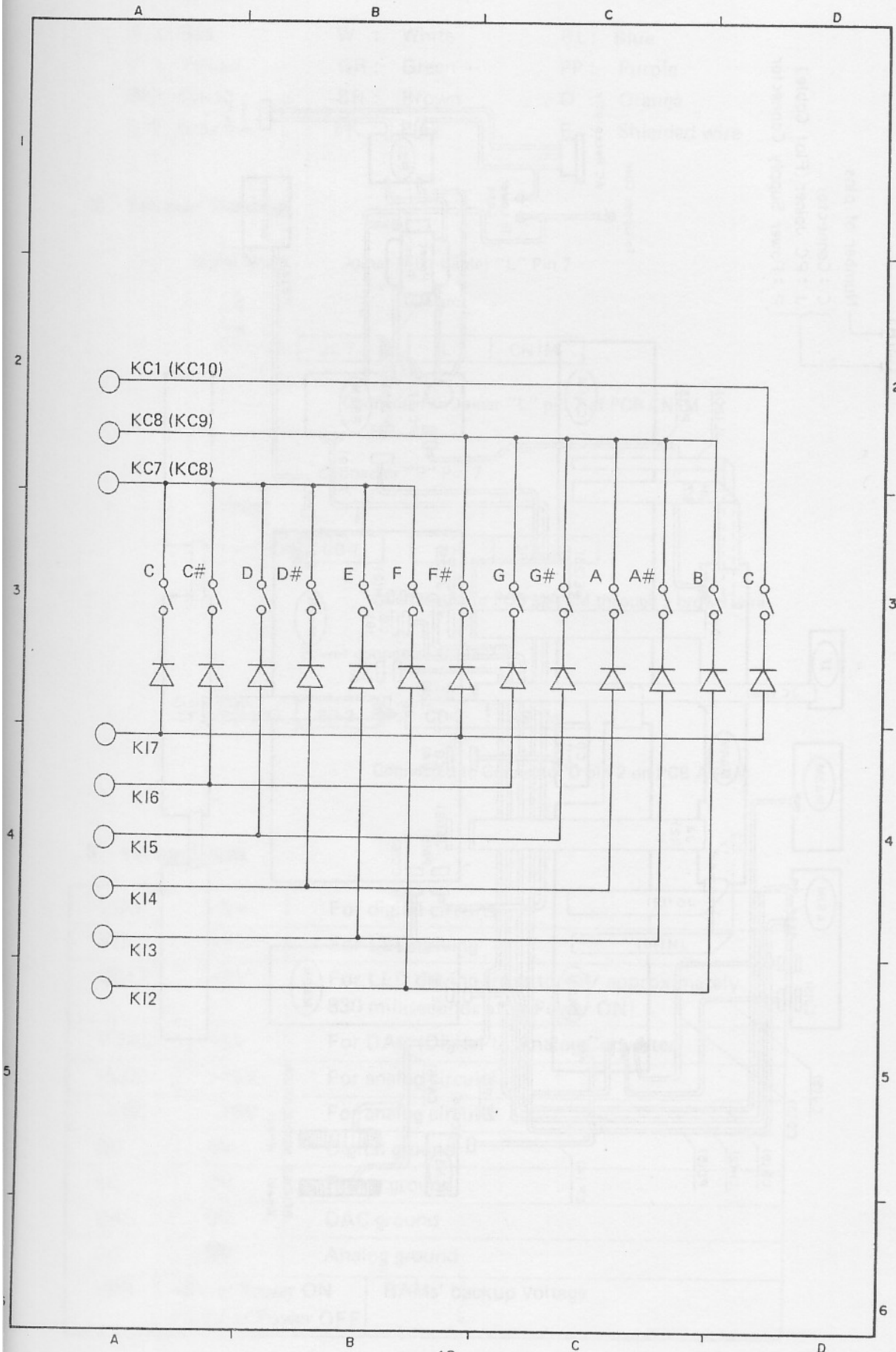

NOTE: 1. Wire Color Codes

R : Red	W : White	BL: Blue
Y : Yellow	GR: Green	PP : Purple
BK: Black	BR : Brown	O : Orange
GY: Gray	PK : Pink	E : Shielded wire

2. Terminal Readings

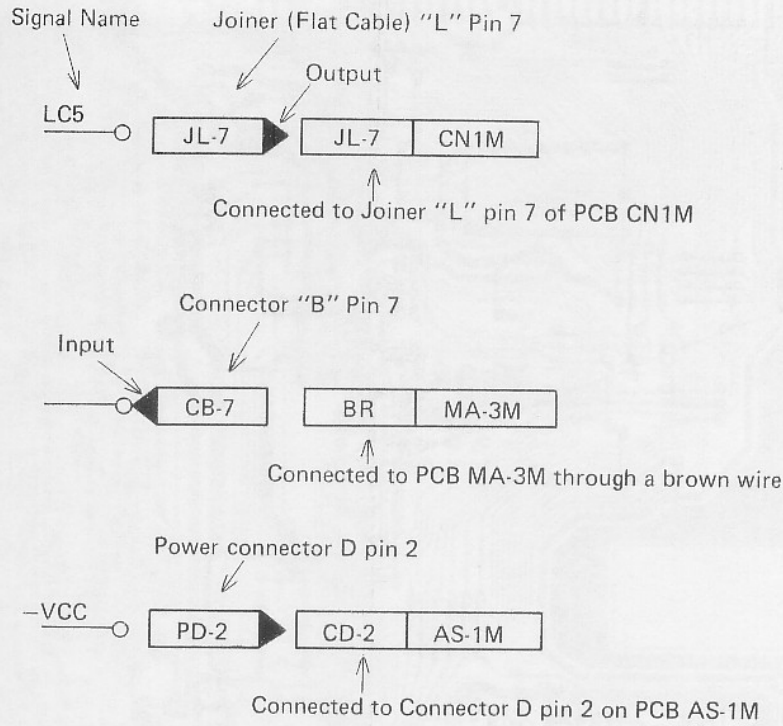

3. Voltage Levels

VDD	+5V	For digital circuits
VDL1	+5V	For LED driving
VDL2	+5V	For LED driving (rises to +5V approximately 830 milliseconds after Power ON)
VDAC	+5V	For DAC (Digital to Analog Converter)
+VCC	+15V	For analog circuits
-VCC	-15V	For analog circuits
DG	0V	Digital ground
FG	0V	Frame ground
DAG	0V	DAC ground
CG	0V	Analog ground
VBR	+5V at Power ON +3.9V at Power OFF	RAMs' backup voltage

3. PCB VIEW & MAJOR CHECKPOINT

3-1. PCB M5153-MA1M

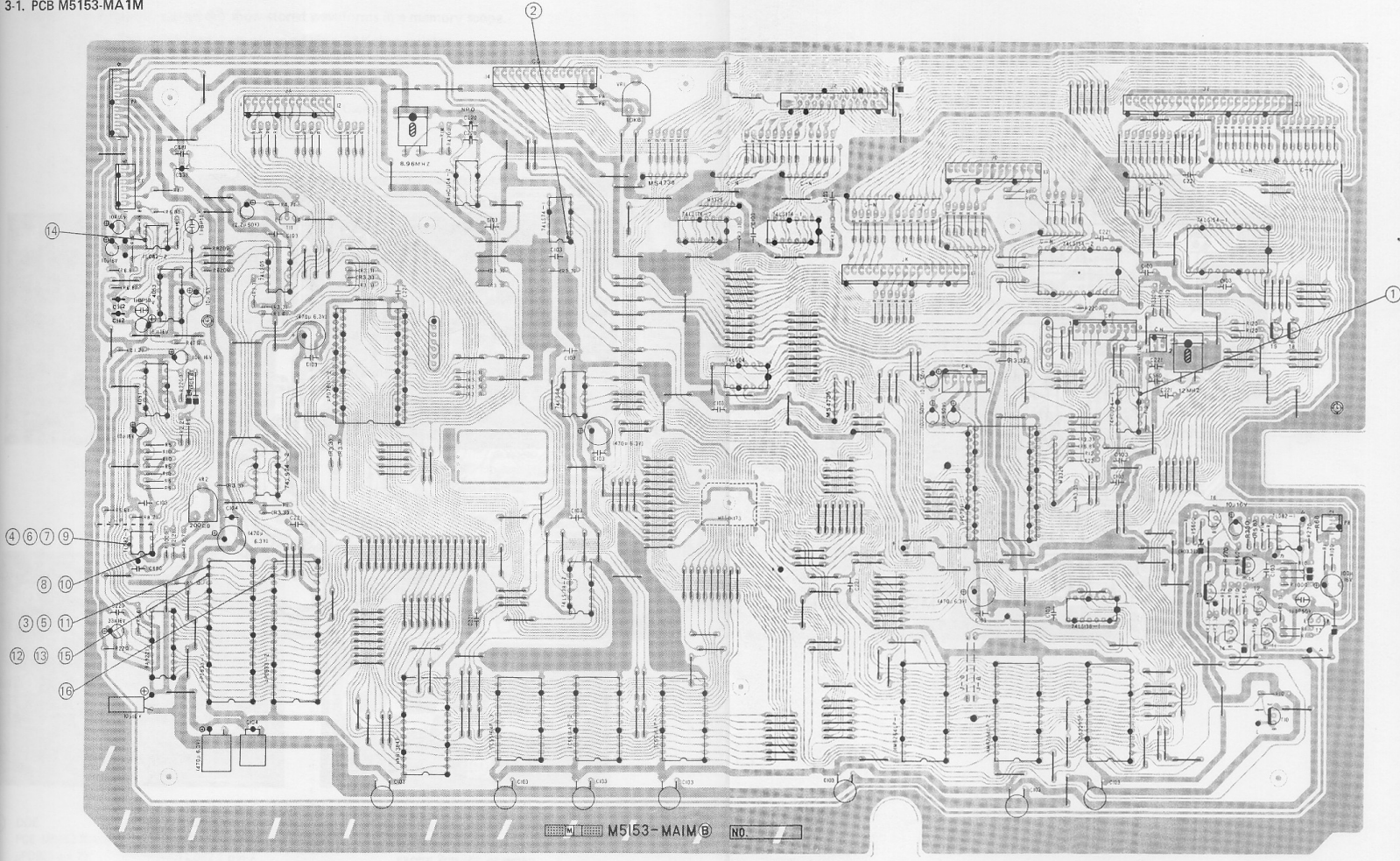

3-2. PCB M5153-MA2M

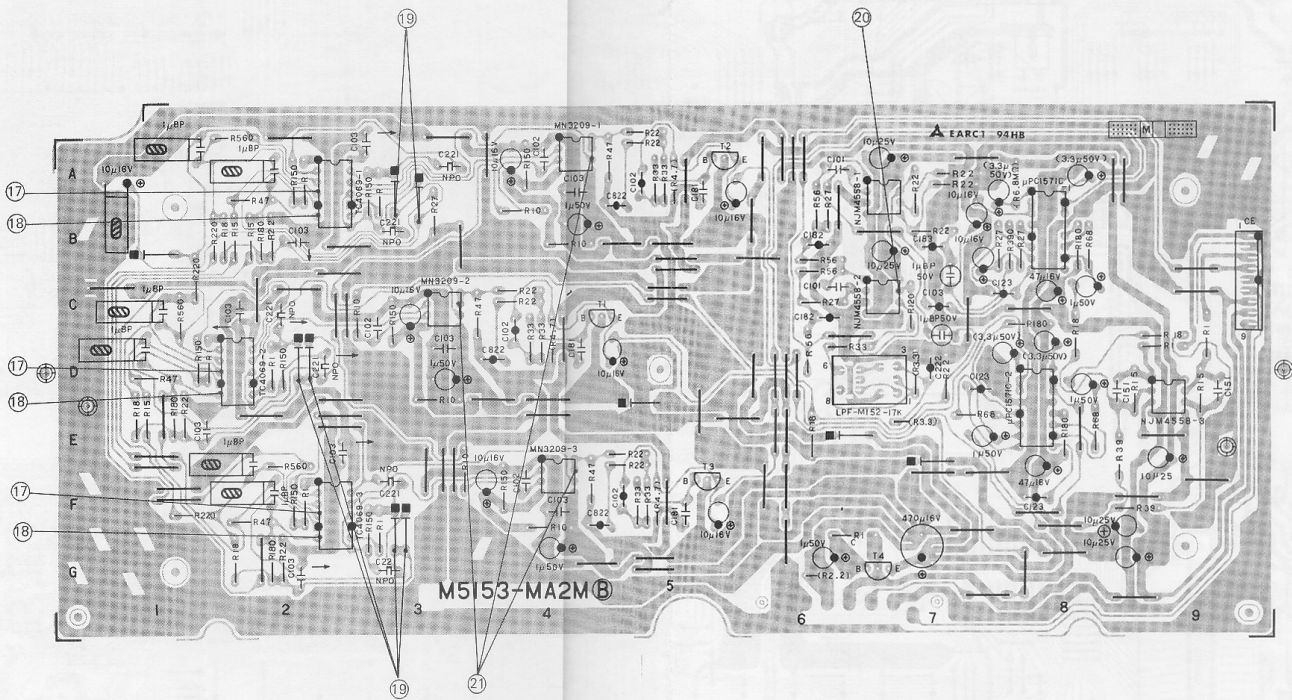

4. MAJOR WAVEFORMS

Notes: Photographs marked (M) show stored waveforms in a memory scope.
The analog waveforms were observed via a 28 Kohm resistor.

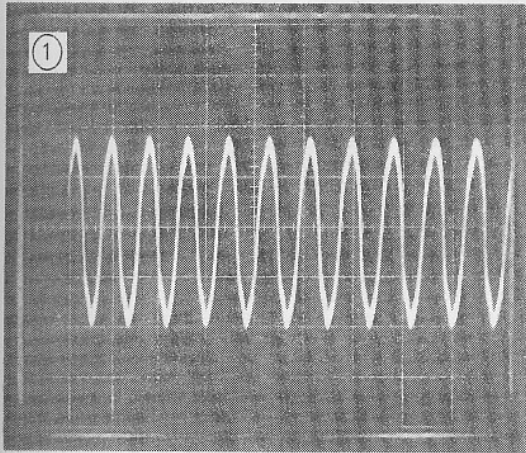
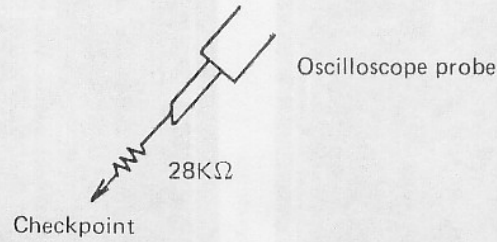

① μ PD7811 clock pulse
PCB M5153-MA1M
74HCU04-1 pin 6
0.1 μ s/div., 2V/div.

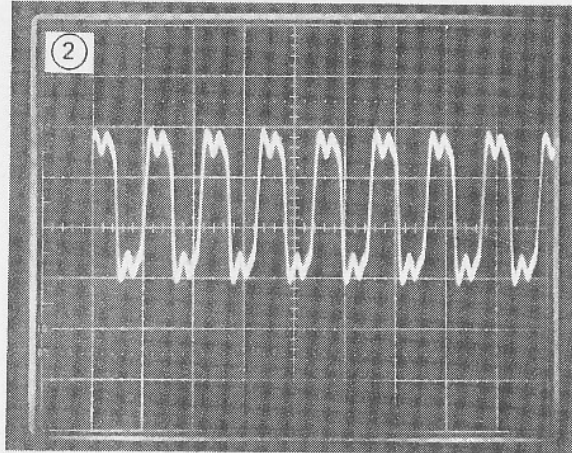

② μ PD933 clock pulse
PCB M5153-MA1M
74HCU04-2 pin 2
0.1 μ s/div., 2V/div.

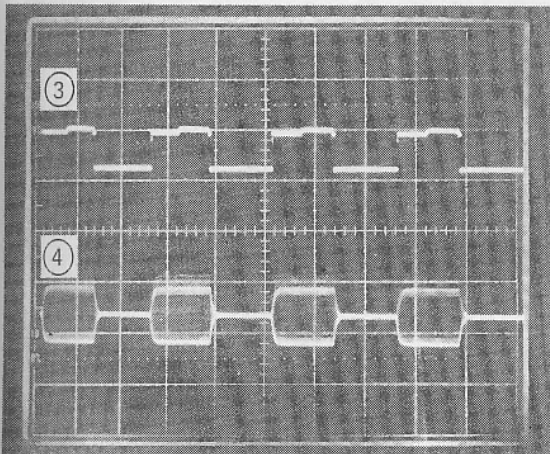

③ DOE
PCB M5153-MA1M
 μ PD933 pin 22
10 μ s/div., 5V/div.
Tone: Flute, Key: C4

④ DAC output
PCB M5153-MA1M
TL082-3 pin 7
10 μ s/div., 5V/div.
Tone: Flute, Key: C4

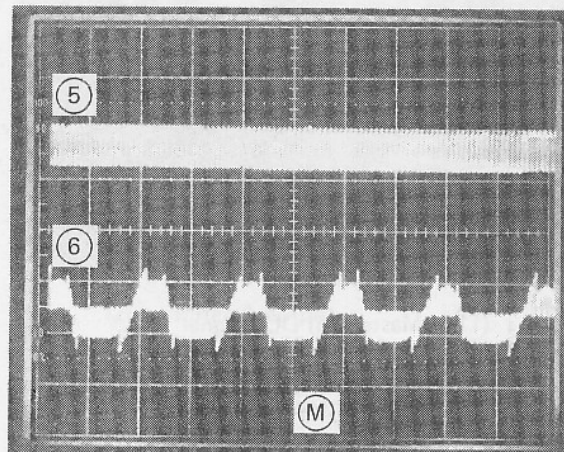

⑤ DOE and ⑥ DAC outputs
Same conditions as ③ and ④
except 2ms/div. of sweep
time and using a memory scope.

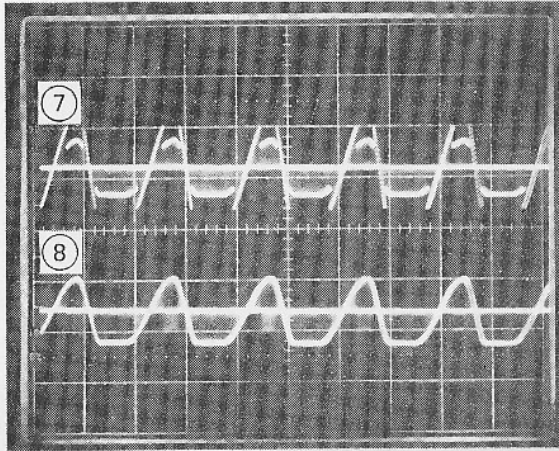

⑦ DAC output
PCB M5153-MA1M
TL082-3 pin 7
2ms/div., 5V/div.
Tone: Flute, Key: C4

⑧ Expander Circuit output
PCB M5153-MA1M
TL082-3 pin 1
2ms/div., 0.5V/div.
Tone: Flute, Key: C4

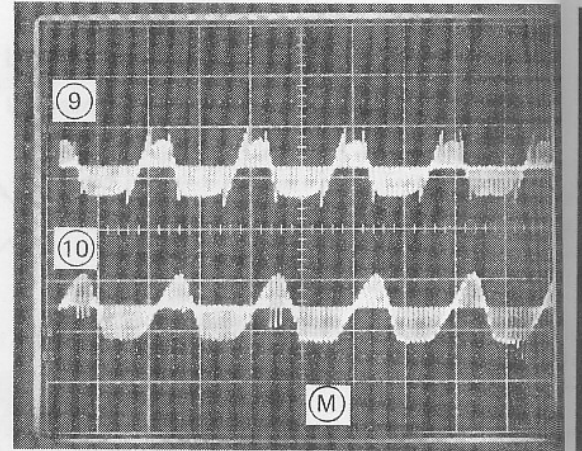

⑨ DAC output and ⑩ Expander
Circuit output
Same conditions as ⑦ and
⑧ except using a memory scope.

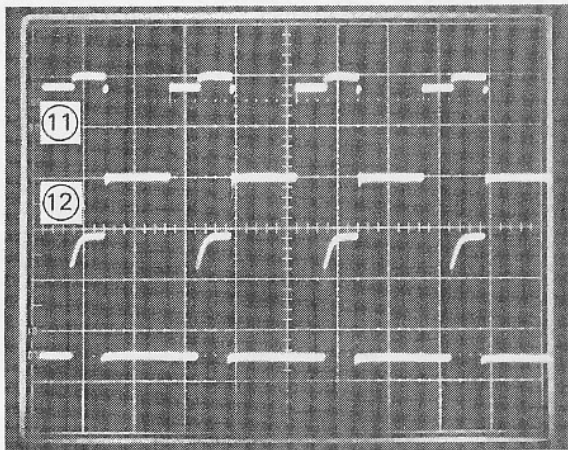

⑪ Master LSI DOE signal
PCB M5153-MA1M
 μ PD933-1 pin 22
10 μ s/div., 2V/div.

⑫ Master LSI SH signal
PCB M5153-MA1M
 μ PD933-2 pin 23
10 μ s/div., 2V/div.

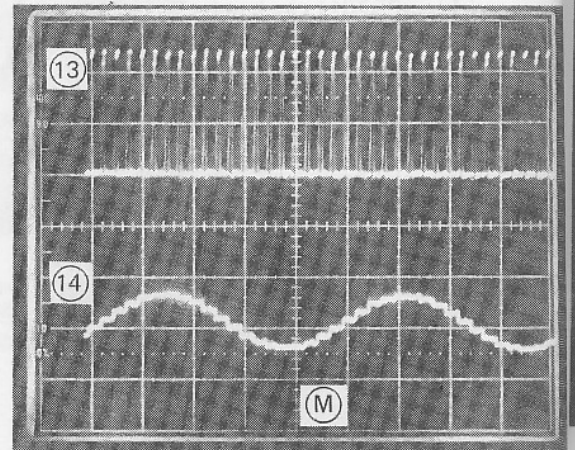

⑬ Master LSI SH signal
PCB M5153-MA1M
 μ PD933-1 pin 23
0.1 μ s/div., 2V/div.

⑭ Sample & Hold Circuit output
PCB M5153-MA1M
TL082-2 pin 7
0.1 μ s/div., 2V/div.
Tone: Flute, Key: C7

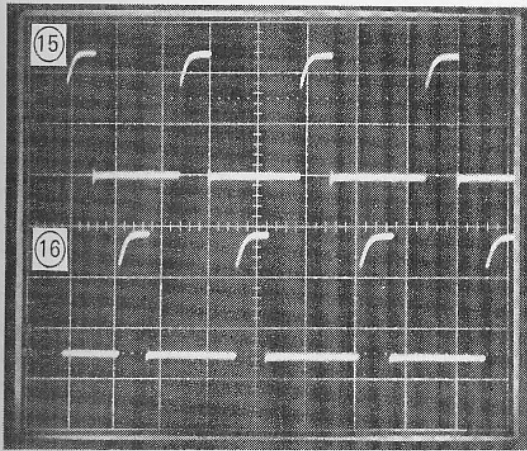

⑮ Master LSI SH signal
PCB M5153-MA1M
 μ PD933-1 pin 23
 $10\mu\text{s}/\text{div.}$, $2\text{V}/\text{div.}$

⑯ Slave LSI SH signal
PCB M5153-MA1M
 μ PD933-2 pin 23
 $10\mu\text{s}/\text{div.}$, $2\text{V}/\text{div.}$

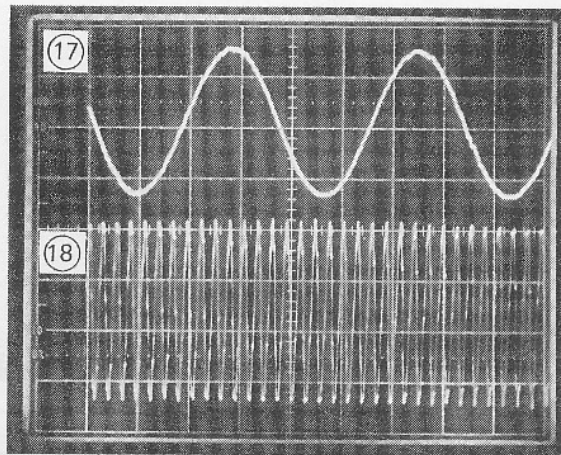

⑰ 0.54Hz LFO output
PCB M5153-MA2M
TC4069-1 pin 4
 $0.5\text{s}/\text{div.}$, $2\text{V}/\text{div.}$

⑱ 6.1Hz LFO output
PCB M5153-MA2M
TC4069-1 pin 6
 $0.5\text{s}/\text{div.}$, $2\text{V}/\text{div.}$

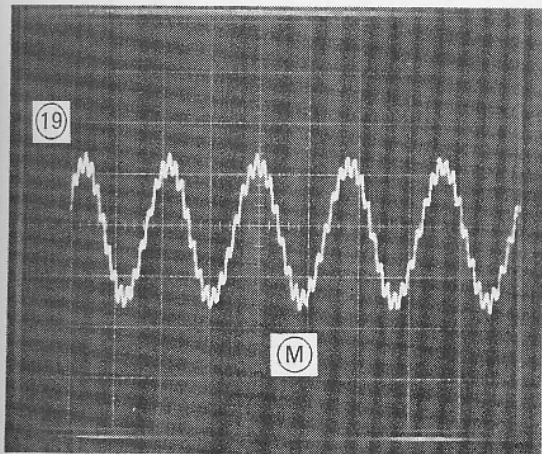

⑲ Mixed 0.54Hz and 6.1 Hz signals
PCB M5153-MA2M
Anode of VCO input diode
 $1\text{s}/\text{div.}$, $1\text{V}/\text{div.}$

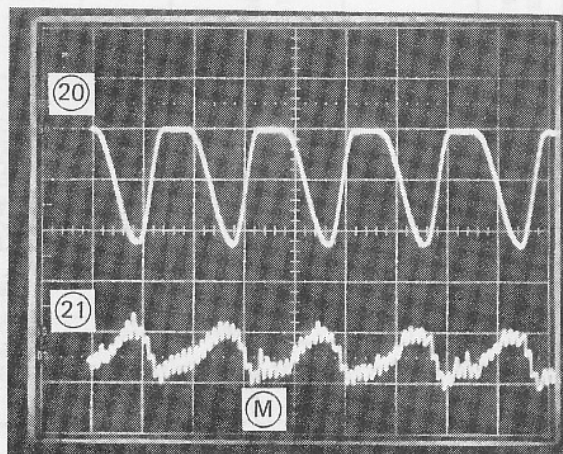

⑳ Filter A output
PCB M5153-MA2M
NJM4558-2 pin 7
 $2\text{ms}/\text{div.}$, $0.5\text{V}/\text{div.}$

㉑ BBD output
PCB M5153-MA2M
MN3209-1 pin 7
 $2\text{ms}/\text{div.}$, $0.5\text{V}/\text{div.}$

5. BLOCK DIAGRAM

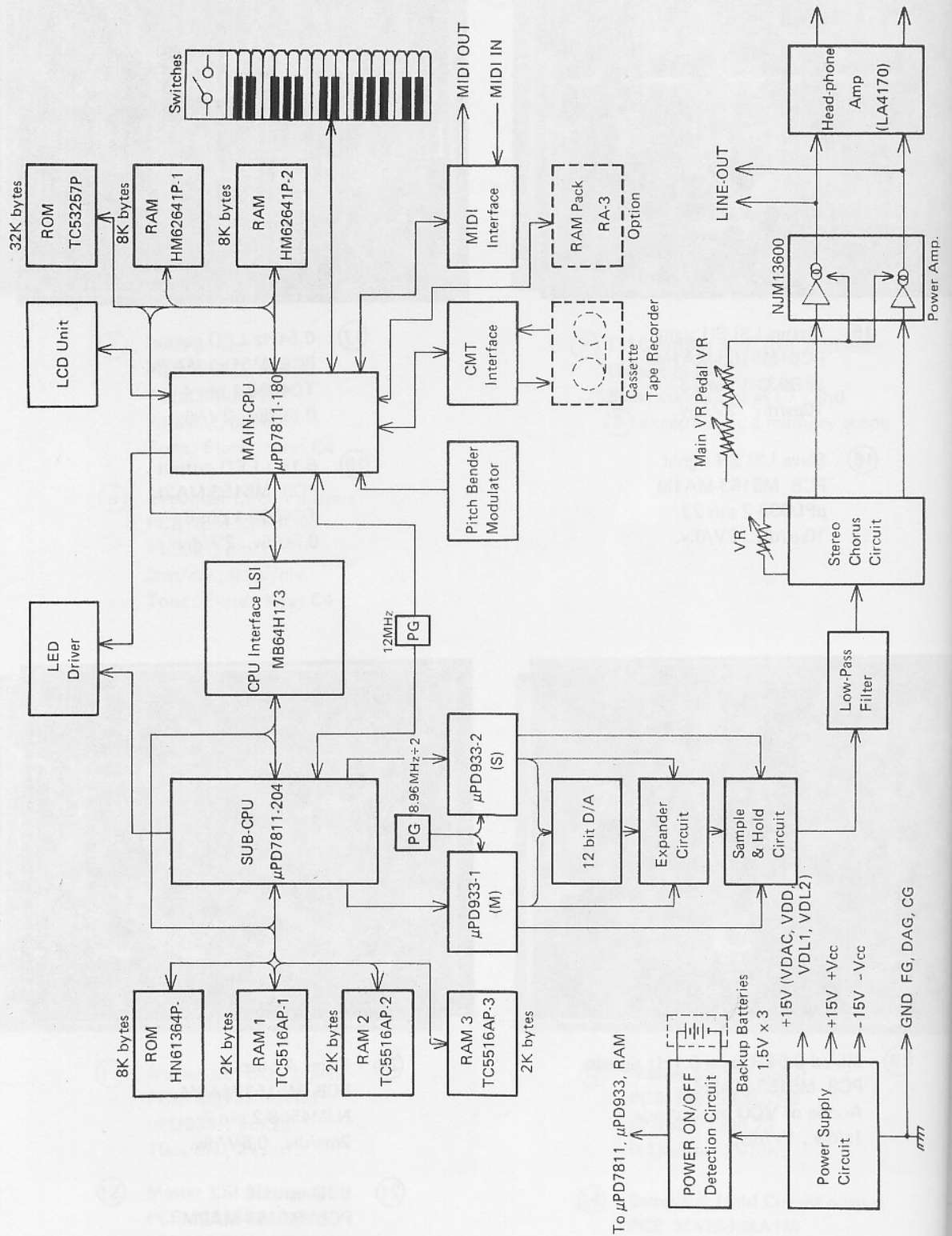

6. DIGITAL CIRCUIT BLOCK DIAGRAM

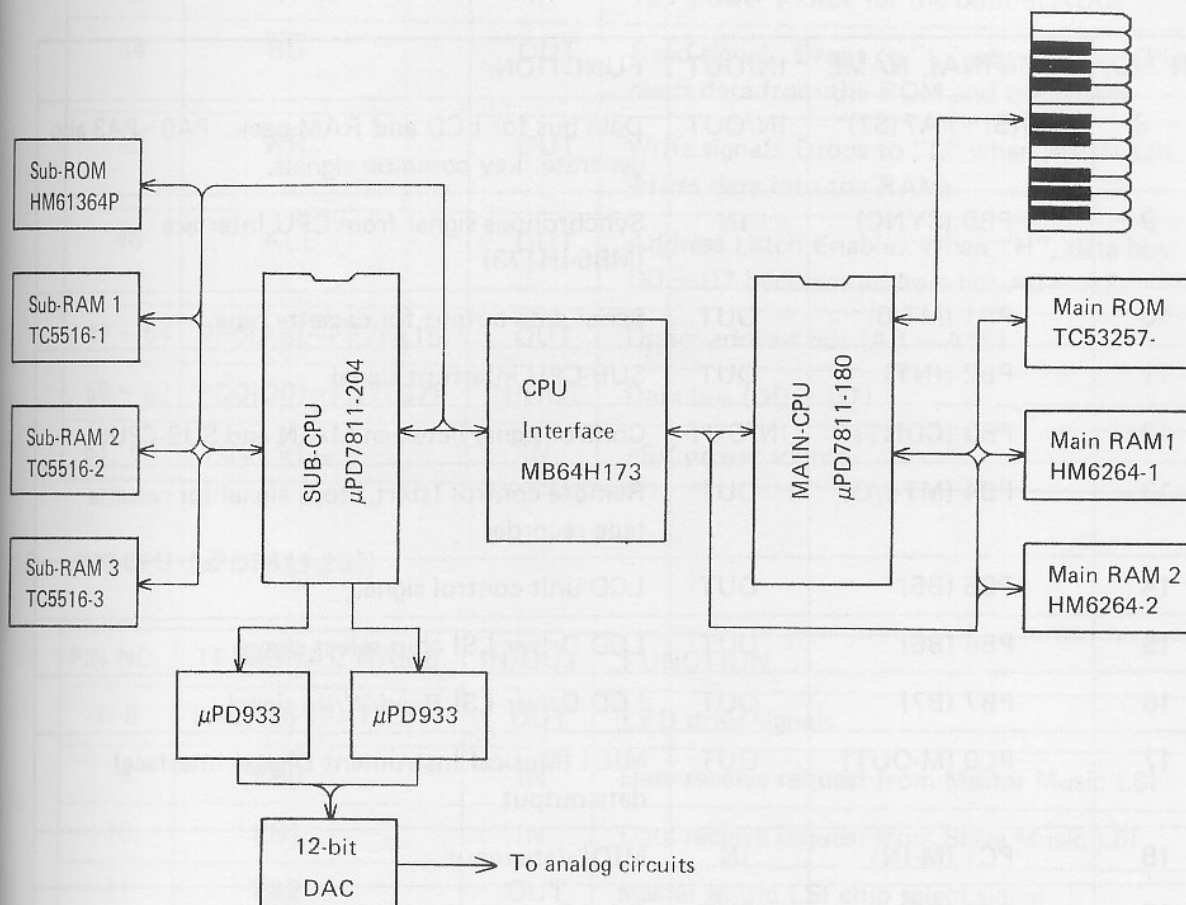

Function of each block:

- MAIN CPU — Controls keys and switches scanning, sequencer, MIDI and cassette tape player.
- SUB-CPU — Mainly controls Music LSIs.
- CPU Interface — Interfaces between MAIN CPU and SUB-CPU.
- Main RAM 1 — The first 2K bytes are for system execution and the rest of 6K bytes store the sequencer data.
- Main RAM 2 — Stores the sequencer data.
- Sub-RAM 1 — Having 2K-byte capacity, stores tone data for Memory Banks A and B.
- Sub-RAM 2 — System execution area.
- Sub-RAM 3 — Stores data fro Memory Banks C and D.

7. MAIN CPU (μ PD7811-180)

PIN NO.	TERMINAL NAME	IN/OUT	FUNCTION
1 ~ 8	PA0(S)~PA7(S7)	IN/OUT	Data bus for LCD and RAM pack. PA0~PA3 also generate key common signals.
9	PB0 (SYNC)	IN	Synchronous signal from CPU Interface (MB64H173)
10	PB1 (MT-0)	OUT	Serial data output for cassette tape
11	PB2 (INT)	OUT	SUB-CPU interrupt signal
12	PB3 (CONT)	IN/OUT	Control signal between MAIN and SUB-CPU's
13	PB4 (MT-I/O)	OUT	Remote control (start, stop) signal for cassette tape recorder
14	PB5 (B5)	OUT	LCD unit control signal
15	PB6 (B6)	OUT	LCD Driver LSI chip select signal
16	PB7 (B7)	OUT	LCD Driver LSI Read/Write signal
17	PC0 (M-OUT)	OUT	MIDI (Musical Instrument Digital Interface) data output
18	PC1 (M-IN)	IN	MIDI data input
19	PC2 (CE)	OUT	RAM Pack (option) chip select signal
20	PC3 (MT-I)	IN	Data input from cassette tape
21 ~ 24	PC4 ~ PC7	OUT	Metronome (timing signal for music recording) pitch signals
26	INT1	IN	Interrupt from SUB-CPU
28	RESET	IN	Initializes the LSI's internal circuits at Power ON.
31	X1	IN	12MHz clock pulse
32	VSS	IN	Logic ground (0V) source
33	AVSS	IN	Ground for the built-in ADC (Analog to Digital Converter)
34	AN0	IN	Bender wheel input. A voltage from the bender wheel is converted into digital data by a built-in ADC.
35	AN1	IN	Modulator wheel input. A voltage from the modulator wheel is converted into digital data by a built-in ADC.
42	VREF	IN	Reference voltage (+5V) for the built-in ADCs

43	AVCC	IN	+5V power source for the built-in ADCs
44	\overline{RD}	OUT	Read signal. Drops to "L" when MAIN CPU reads data from the ROM and the RAMs.
45	\overline{WR}	OUT	Write signal. Drops to "L" when MAIN CPU writes data into the RAMs.
46	ALE	OUT	Address Latch Enable. When "H", data bus D0 ~ D7 becomes address bus A0 ~ A7.
47 ~ 54	PF0(A8)~PF7(A15)	OUT	Upper address bus (A8 ~ A15)
55 ~ 62	PD0(D0)~PD7(D7)	IN/OUT	Data bus (D0 ~ D7)
63, 64	VDD, VCC	IN	+5V power source

8. SUB-CPU (μ PD7811-204)

PIN NO.	TERMINAL NAME	IN/OUT	FUNCTION
1~8	PA0(L0)~PA7(L7)	OUT	LED drive signals
9	PB0	IN	Data receive request from Master Music LSI
10	PB1	IN	Data receive request from Slave Music LSI
11	PB2	OUT	Master Music LSI chip select signal
12	PB3	OUT	Slave Music LSI chip select signal
13	PB4	OUT	Write enable signal for Music LSIs
14	PB5	OUT	ID (Interrupt Disable) signal. When SUB-CPU is busy, it sends ID signal to Music LSIs so as not to be interrupted.
15	PB6 (LDC)	OUT	Stays "H" level for approximately 830 milliseconds after the power switch is turned on in order to avoid mis-lighting the LEDs at Power ON.
17	PC0 (TXD, L11)	OUT	LED drive signal
18	PC1 (RXD, SYNC)	IN	Synchronous signal from MAIN CPU
19	PC2 (SCK, CONT)	IN/OUT	Control signal between MAIN and SUB-CPU
20	PC3 (INT2)	IN	Interrupt signal from Music LSIs
21	PC4 (T0)	OUT	Metronome envelope signal
22~24	PC5(L8)~PC7(L10)	OUT	LED drive signals
26	INT1	IN	Interrupt signal from MAIN CPU

28	$\overline{\text{RESET}}$	IN	At Power ON, the terminal stays "L" level for a while in order to initialize the internal circuits.
31	X1	IN	12MHz clock pulse
32	VSS	IN	Ground (0V) power source
44	$\overline{\text{RD}}$	OUT	Read signal. Drops to "L" when SUB-CPU reads data from the ROM, RAMs or Music LSIs.
45	$\overline{\text{WR}}$	OUT	Write signal. Drops to "L" when SUB-CPU writes data into the RAMs or Music LSIs.
46	ALE	OUT	Address Latch Enable. When "H", data bus PD9 (DS0) ~ PD7 (DS7) becomes address bus AS0 ~ AS7.
47~54	PF0(AS15) ~ PF7 (AS8)	OUT	Upper address bus
55~62	PD0(DS0) ~ PD7 (DS7)	OUT	Data bus
63, 64	VDD, VCC	IN	+5V power source

9. MAIN RAMS & ROM ACCESS

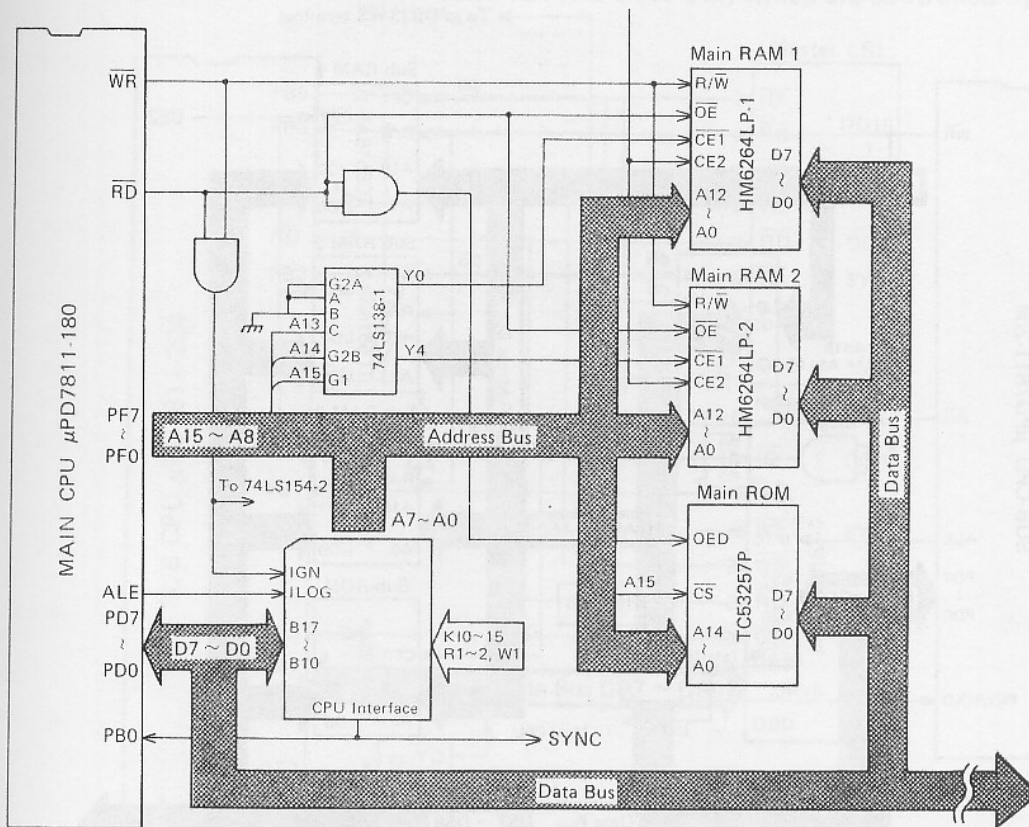

The first 2K bytes of Main RAM 1 are the data area for system execution and the rest of 6K bytes and the whole 8K bytes of Main RAM 2 are the data area for programmed music.

The capacity of Main ROM is 32K bytes and contains the program for system execution.

The lower address bus A0 ~ A7 is provided from CPU Interface LSI. When signal ALE from MAIN CPU rises to "H", data bus (D0 ~ D7) becomes address bus (A0 ~ A7) in CPU Interface LSI. The upper address A8 ~ A15 is directly supplied from MAIN CPU.

Chip select signals are provided from signals A13 ~ A15:

A13	A14	A5	
L	L	H	Main RAM1 chip selection
H	L	L	Main RAM2 chip selection
X	X	L	Main ROM chip selection

'LS138, 'S138 FUNCTION TABLE

INPUT				OUTPUT							
ENABLE		SELECT									
G1	G2*	C	B A	Y0	Y1	Y2	Y3	Y4	Y5	Y6	Y7
X	H	X	X X	H	H	H	H	H	H	H	H
L	X	X	X X	H	H	H	H	H	H	H	H
H	L	L	L L	L	H	H	H	H	H	H	H
H	L	L	L H	H	L	H	H	H	H	H	H
H	L	L	H L	H	H	L	H	H	H	H	H
H	L	L	H H	H	H	H	L	H	H	H	H
H	L	H	L L	H	H	H	H	H	L	H	H
H	L	H	L H	H	H	H	H	H	H	L	H
H	L	H	H L	H	H	H	H	H	H	H	L
H	L	H	H H	H	H	H	H	H	H	H	L

* G2 = G2A + G2B

H = high level, L = low level, X = irrelevant

10. SUB-RAMS & ROM ACCESS

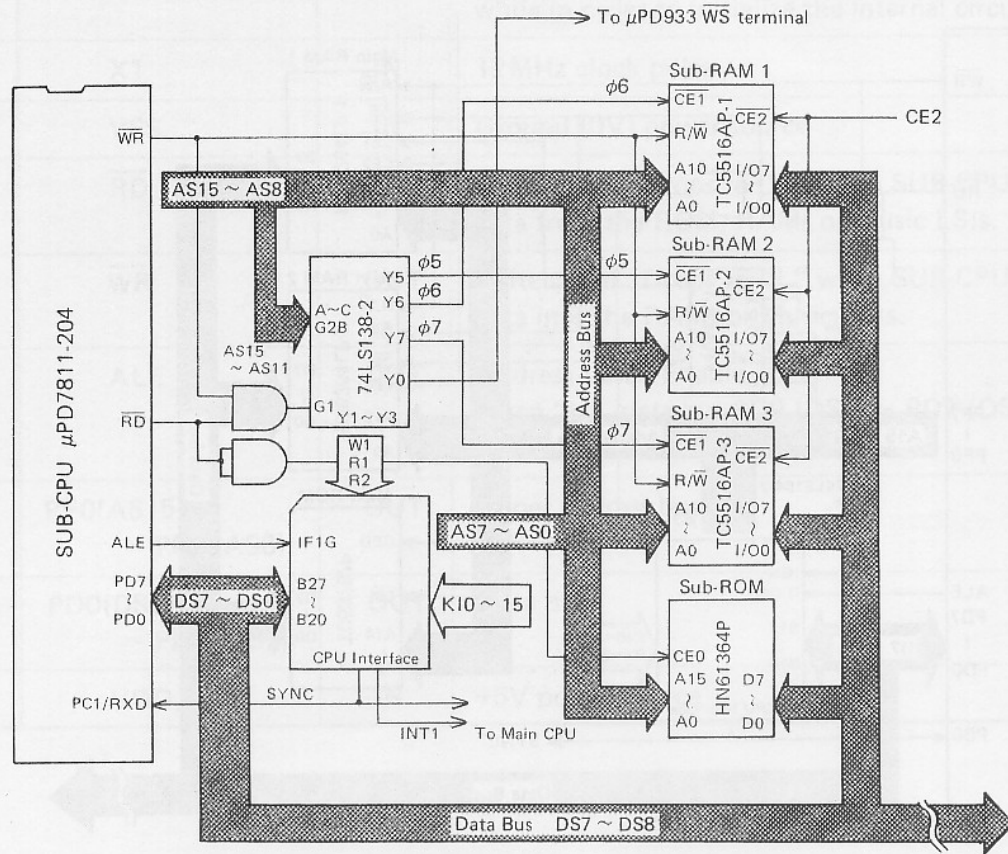

TC5516AP is a 2K-byte RAM while HN61364P is an 8K-byte ROM.

Sub-RAM 1 – Tone data area for Memory Banks A and B.

Sub-RAM 2 – Data area for system execution.

Sub-RAM 3 – Tone data area for Memory Banks C and D.

In the same procedures as for MAIN CPU, lower address bus AS0 ~ AS7 is generated from data bus DS0 ~ DS7 in CPU Interface LSI when signal ALE is "H". Upper address signals A8 ~ A15 are provided from SUB-CPU directly.

Decoder 74LS138 generates chip selection signals and other control signals from signals AS11 ~ AS15 as follows:

74LS138		74LS138														
		IN					OUT									
A15	G1	Y0	A14	A15	A13	A12	A11	Y0	Y1	Y2	Y3	Y4	Y5	Y6	Y7	
			L	H	L	L	L	L	H	H	H	H	H	H	H	Write strobe for Music LSIs
			L	H	L	L	H	H	L	H	H	H	H	H	H	Data transfer: SUB-CPU → MAIN CPU
RD-WR	G2B	Y2	L	H	L	H	L	H	H	L	H	H	H	H	H	Data transfer: MAIN CPU → SUB-CPU
A11	A	Y3	L	H	L	H	H	H	H	L	H	H	H	H	H	Data transfer: MAIN CPU → SUB-CPU
A12	B	Y4	L	H	H	L	L	H	H	H	H	L	H	H	H	MAIN CPU interruption
A13	C	Y5	L	H	H	L	H	H	H	H	H	H	L	H	H	Sub-RAM2 chip selection
		Y6	L	H	H	H	L	H	H	H	H	H	H	L	H	Sub-RAM1 chip selection
		Y7	L	H	H	H	H	H	H	H	H	H	H	H	L	Sub-RAM3 chip selection

11. MUSIC LSI ACCESS

CZ-5000 employs two Music LSIs, Master LSI and Slave LSI, which are controlled by SUB-CPU.

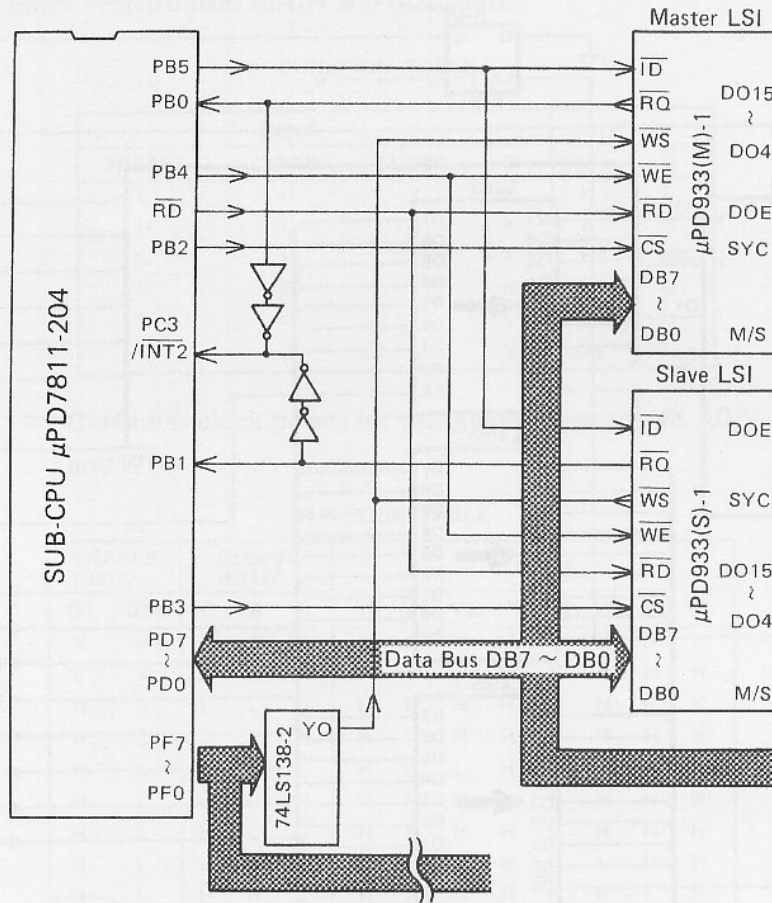

1) SUB CPU ⇒ Music LSI

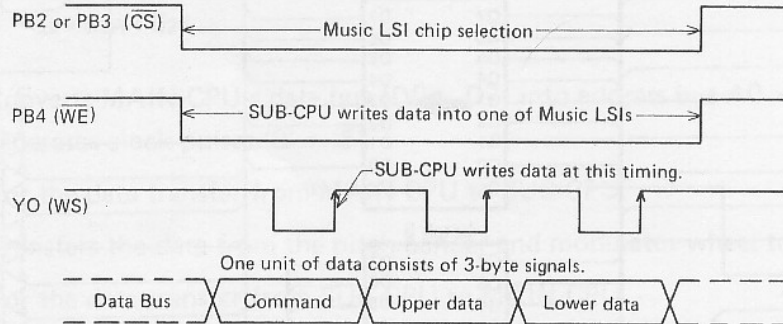

2) Music LSI ⇒ SUB-CPU

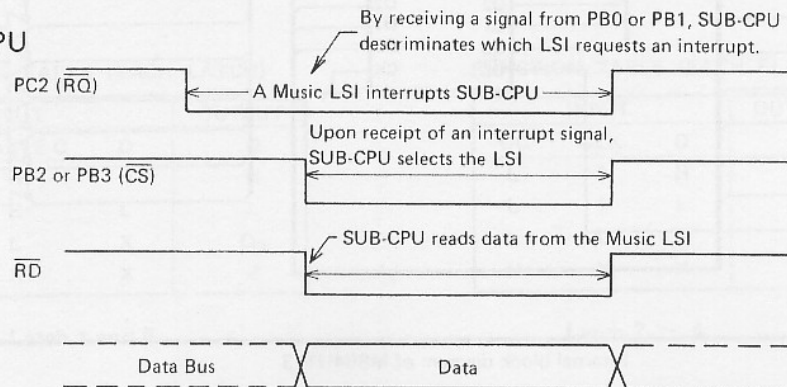

12. CPU INTERFACE (MB64H173)

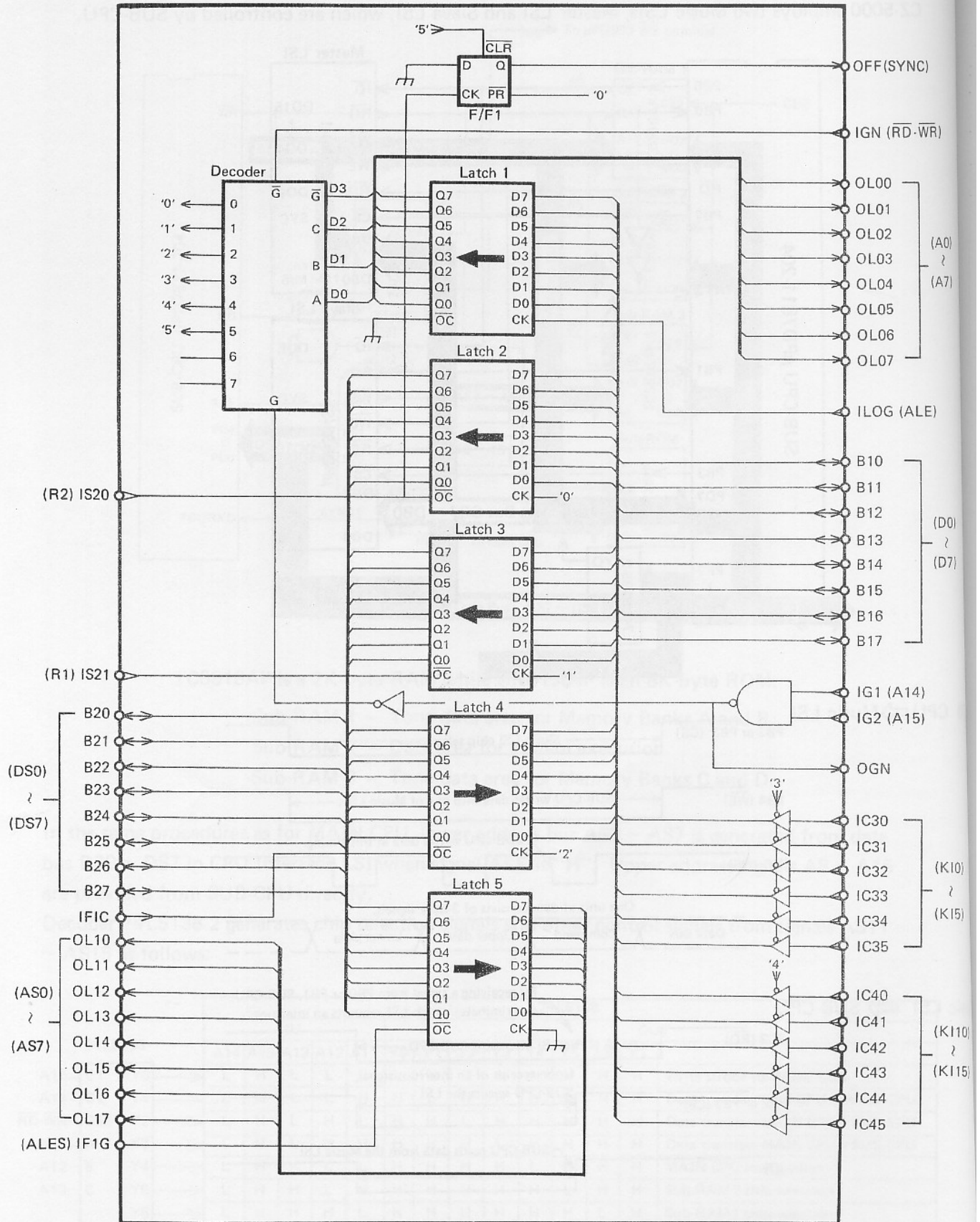

Internal block diagram of MB64H173

12.1. Function of Each Block

F/F 1 — Set by the clock pulse '0' and signal R2 from SUB-CPU, and generates signal SYNC which synchronizes MAIN and SUB-CPU's.

FUNCTION TABLE

INPUT				OUTPUT	
PRESET	CLEAR	CLOCK	D	Q	\bar{Q}
L	H	X	X	H	L
H	L	X	X	L	H
L	L	X	X	H*	H*
H	H	↑	H	H	L
H	H	↑	L	L	H
H	H	L	X	Q_0	\bar{Q}_0

Decoder 1 — Generates clock pulses for the latches from signals A0 ~ A3, A14, A15, \bar{RD} and \bar{WR} .

FUNCTION TABLE

ENABLE INPUT		SELECT INPUT			OUTPUT							
G1	$\bar{G}2^*$	C	B	A	Y0	Y1	Y2	Y3	Y4	Y5	Y6	Y7
X	H	X	X	X	H	H	H	H	H	H	H	H
L	X	X	X	X	H	H	H	H	H	H	H	H
H	L	L	L	L	L	H	H	H	H	H	H	H
H	L	L	L	H	H	L	H	H	H	H	H	H
H	L	L	H	L	H	H	L	H	H	H	H	H
H	L	L	H	H	H	H	H	L	H	H	H	H
H	L	H	L	L	H	H	H	H	L	H	H	H
H	L	H	L	H	H	H	H	H	H	L	H	H
H	L	H	H	L	H	H	H	H	H	H	L	H
H	L	H	H	H	H	H	H	H	H	H	H	L

$$*\bar{G}2 = \bar{G}2A + \bar{G}2B$$

Latch 1 — Converts MAIN CPU's data bus (D0 ~ D7) into address bus A0 ~ A7, and generates clock pulses '0' ~ '5'.

Latch 2 — For the data transfer from MAIN CPU to SUB-CPU.

Latch 3 — Transfers the data from the pitch bender and modulator wheel to SUB-CPU.

Latch 4 — For the data transfer from SUB-CPU to MAIN CPU.

Latch 5 — Converts SUB-CPU's data bus (DS0 ~ DS7) into address bus AS0 ~ AS7.

FUNCTION TABLE (EACH LATCH)

INPUT			OUTPUT
\bar{OC}	ENABLE C	D	Q
L	H	H	H
L	H	L	L
L	L	X	Q_0
H	X	X	Z

Latch 1 and 5

FUNCTION TABLE (EACH FLIP-FLOP)

INPUT			OUTPUT
\bar{OC}	CLK	D	Q
L	↑	H	H
L	↑	L	L
L	L	X	Q_0
H	X	X	Z

Latch 2 ~ 4

12-2. Data Transfer Procedures

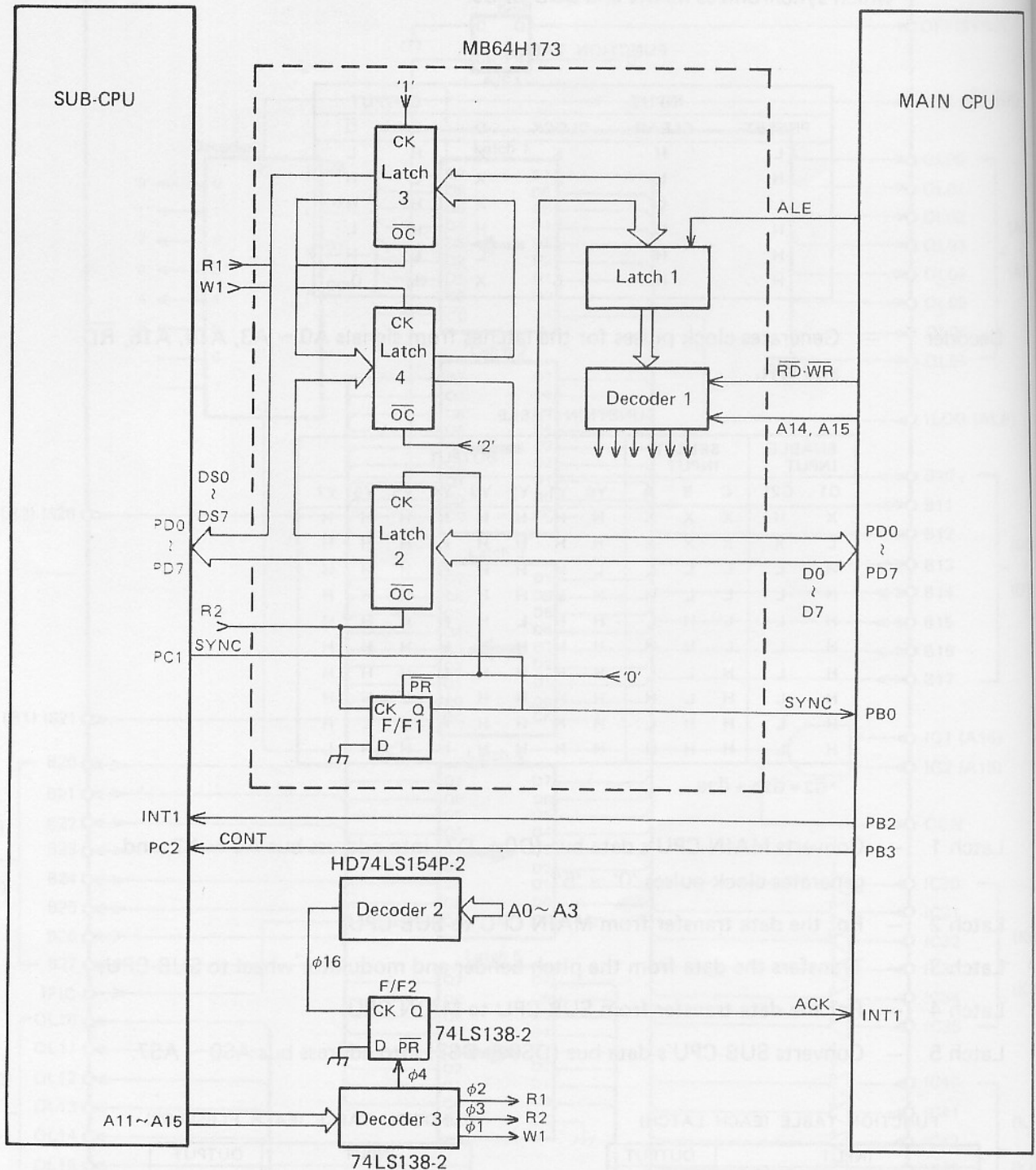

(1) Pitch Bender & Modulator \Rightarrow SUB-CPU.

- ① Voltage level from the pitch bender or the modulator is converted into digital data in the CPU's built-in ADC (Analog to Digital Converter) and output from data bus (D0 ~ D7).
- ② The data is entered into CPU Interface LSI.
- ③ Sending signal R1, SUB-CPU sets Latch 3 and reads data periodically.

(2) MAIN CPU \Rightarrow SUB-CPU.

- ① Via Latch 1 and Decoder 1, MAIN CPU drops clock pulse '0' to "L" level.
By clock pulse '0', F/F 1 is preset to rise signal SYNC.
- ② MAIN CPU puts data on data bus D0 ~ D7, and at the same time, clock pulse '0' rises to "H" level.
At the rising edge of clock pulse '0', data from MAIN CPU is set in Latch 2.
- ③ MAIN CPU interrupts SUB-CPU from terminal PB2, and simultaneously generates signal CONT from terminal PB3.
- ④ Generating signal R2 from Decoder 3, SUB-CPU reads the data from Latch 2 via data bus DS0 ~ DS7.
- ⑤ SUB-CPU sends signal ACK to MAIN CPU via Decoder 3 and F/F 2.
Upon receipt of signal ACK, MAIN CPU confirms that SUB-CPU has received the data and generates signal $\phi 16$ in Decoder 2.
- ⑥ When all the data have sent to SUB-CPU by repeating the above procedures ① ~ ⑤, MAIN CPU drops signal CONT to "L".
- ⑦ Confirming that both CONT and SYNC are "L", SUB-CPU determines that all the data have been received.

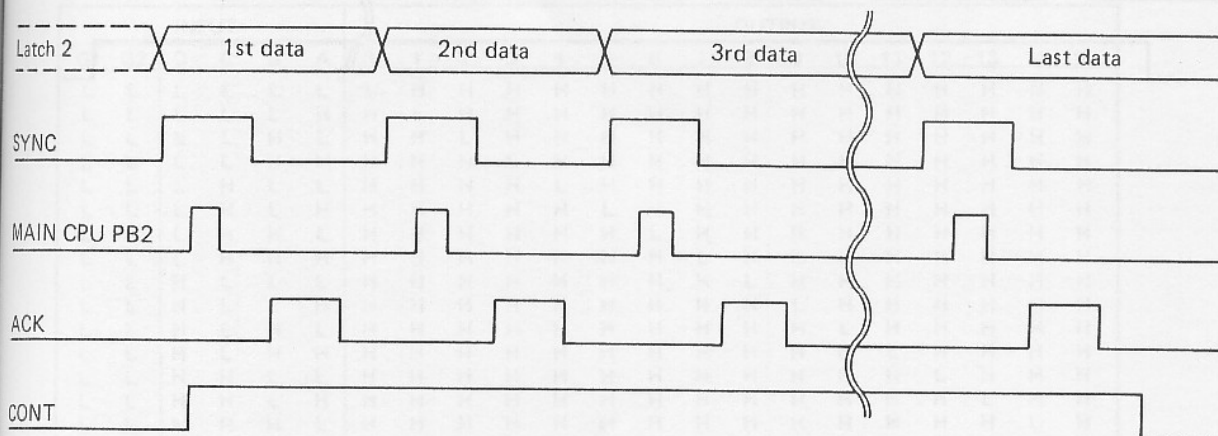

(3) Sub-CPU \Rightarrow MAIN CPU.

- ① In the same procedures as stated in the item (2), MAIN CPU sends "Request Command" that inquires SUB-CPU to transmit data.
- ② SUB-CPU puts data on the data bus DS0 ~ DS7 and sets the data in Latch 4 by signal W1. SUB-CPU then presets F/F 2 by pulse $\phi 4$, causing signal ACK to be entered in MAIN CPU.
- ③ Acknowledging that the data is set in Latch 4 by signal ACK, MAIN CPU generates clock pulse '2', causing the data from SUB-CPU to be put on MAIN CPU data bus D0 ~ D7.
- ④ After receiving the data, MAIN CPU sends SUB-CPU an interrupt signal from terminal PB2, and by the interrupt signal, SUB-CPU confirms that the data is received by MAIN CPU.
- ⑤ Repeating the above procedures ② ~ ④, SUB-CPU sends the next data to MAIN CPU.

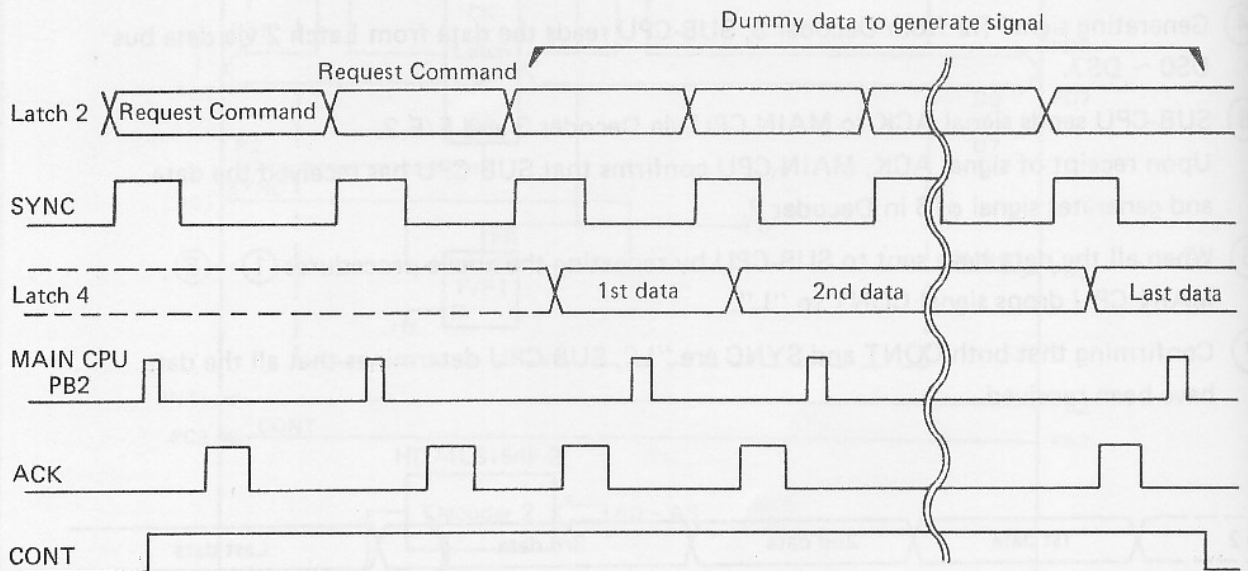

(4) Key and switch scanning

Receiving a key common signal from data bus, MAIN CPU discriminates a key or a switch input.

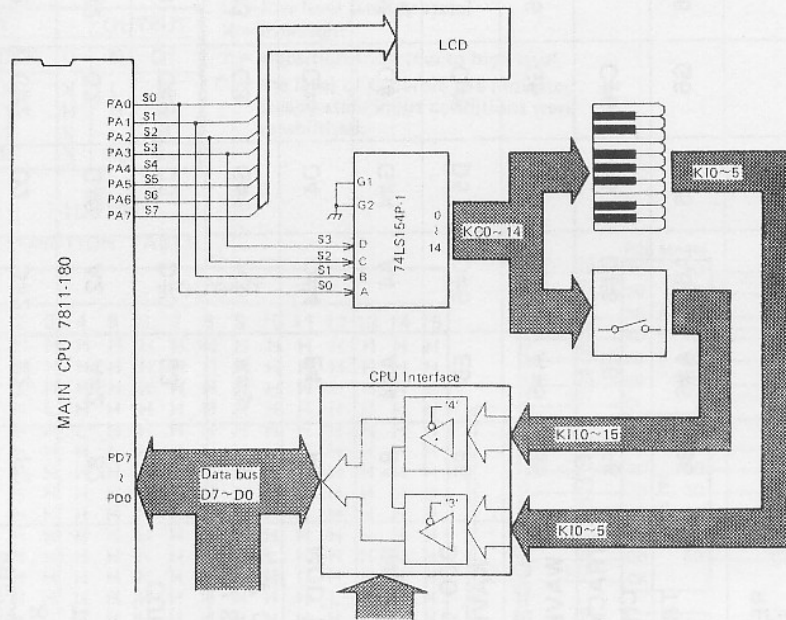

- ① From signals PA0 ~ PA3 of MAIN CPU, 4-line to 16-line decoder 74LS154P-1 generates key common signals KC0 ~ KC14.
- ② When a key or a switch is hit, one of the input signals K10 ~ K15 (for keys) or K110 ~ K115 (for switches) is entered in CPU Interface MB64H173.
- ③ MAIN CPU generates the clock pulse '3' (for keys) or '4' (for switches), causing the tristate buffers to be opened.
- ④ The input pulse is entered into data bus.
- ⑤ Discriminating the contents of the data bus, MAIN CPU determines which key is hit.

INPUT					OUTPUT																
G1	G2	D	C	B	A	0	1	2	3	4	5	6	7	8	9	10	11	12	13	14	15
L	L	L	L	L	L	L	H	H	H	H	H	H	H	H	H	H	H	H	H	H	H
L	L	L	L	L	H	H	L	H	H	H	H	H	H	H	H	H	H	H	H	H	H
L	L	L	L	H	L	H	H	L	H	H	H	H	H	H	H	H	H	H	H	H	H
L	L	L	L	H	L	H	H	H	L	H	H	H	H	H	H	H	H	H	H	H	H
L	L	L	H	L	H	H	H	H	H	L	H	H	H	H	H	H	H	H	H	H	H
L	L	L	H	H	L	H	H	H	H	H	L	H	H	H	H	H	H	H	H	H	H
L	L	L	H	L	L	H	H	H	H	H	H	L	H	H	H	H	H	H	H	H	H
L	L	H	L	L	H	H	H	H	H	H	H	H	L	H	H	H	H	H	H	H	H
L	L	H	L	H	L	H	H	H	H	H	H	H	H	L	H	H	H	H	H	H	H
L	L	H	H	L	H	H	H	H	H	H	H	H	H	H	L	H	H	H	H	H	H
L	L	H	H	H	L	H	H	H	H	H	H	H	H	H	H	L	H	H	H	H	H
L	L	H	H	H	H	H	H	H	H	H	H	H	H	H	H	H	L	H	H	H	L
L	H	X	X	X	X	H	H	H	H	H	H	H	H	H	H	H	H	H	H	H	H
H	L	X	X	X	X	H	H	H	H	H	H	H	H	H	H	H	H	H	H	H	H
H	H	X	X	X	X	H	H	H	H	H	H	H	H	H	H	H	H	H	H	H	H

74LS154P Function Table

13. KEY MATRIX

	K10	K11	K12	K13	K14	K15	KI 10	KI 11	KI 12	KI 13	KI 14	KI 15
KC0	C2	C#2	D2	D#2	E2	F2	PRESET BANK-C	PRESET BANK-D	PRESET BANK-A	MEMORY BANK-B	MEMORY BANK-C	MEMORY BANK-D
KC1	F#2	G2	G#2	A2	A#2	B2	5 TONE	6 TONE	7 TONE	8 TONE	PRESET BANK-A	PRESET BANK-B
KC2	C3	C#3	D3	D#3	E3	F3	CURSOR NO	CURSOR YES	1 TONE	2 TONE	3 TONE	4 TONE
KC3	F#3	G3	G#3	A3	A#3	B3	ENV STEP ▼ DOWN	ENV STEP ▲ UP	ENV POINT SUSTAIN	ENV POINT END	VALUE ▼ SAVE	VALUE ▲ LOAD
KC4	C4	C#4	D4	D#4	E4	F4	MOD. DEPTH	BEND RANGE	GLIDE	PORTAMENTO	MT	CARTRIDGE
KC5	F#4	G4	G#4	A4	A#4	B4	INITIALISE	OCTAVE	VIBRATO	LINE SELECT	RING	NOISE
KC6	C5	C#5	D5	D#5	E5	F5	DCO 1 WAVEFORM	DCO 1 ENV	DCW 1 KEY-F	DCW 1 ENV	DCA 1 KEY-F	DCA 1 ENV
KC7	F#5	G5	G#5	A5	A#5	B5	DOC 2 WAVEFORM	DCO 2 ENV	DCW 2 KEY-F	DCW 2 ENV	DCA 2 KEY-F	DCA 2 ENV
KC8	C6	C#6	D6	D#6	E6	F6	TRACK CHECK	REPEAT	TEMPO ▲ UP	TEMPO ▼ DOWN	DELETE	DETUNE
KC9	F#6	G6	G#6	A6	A#6	B6	3 TRACK	4 TRACK	5 TRACK	6 TRACK	7 TRACK	8 TRACK
KC10	C7						RESET	RECORD	REC. TRACK MANUAL	REC. TRACK REAL TIME	TRACK 1	TRACK 2
KC11							STOP	PLAY	FWD	REV	MEMORY PROTECT	FOOT SW (SUS)
KC12												MODULATION ON/OFF
KC13	C2						NORMAL	1 TONE MIX	2 KEY SPLIT	3 SEQUENCER	4 SOLO	5 MIDI
KC14							PORTAMENTO ON/OFF	GLIDE ON/OFF	KEY TRANSPOSE	MASTER TUNE	COMPARE/RECALL	WRITE



14. LED DRIVING CIRCUITS

74LS174

FUNCTION TABLE
(EACH FLIP-FLOP)

INPUT			OUTPUT	
CLEAR	CLOCK	D	Q	\bar{Q}
L	X	X	L	H
H	↑	H	H	L
H	↑	L	L	H
H	L	X	Q ₀	\bar{Q}_0

H = high level (steady state)
L = low level (steady state)
X = irrelevant
↑ = transition from low to high level
Q₀ = the level of Q before the indicated steady-state input conditions were established.

74LS154P

FUNCTION TABLE

INPUT				OUTPUT																	
IG2	D	C	B	A	0	1	2	3	4	5	6	7	8	9	10	11	12	13	14	15	
L	L	L	L	L	L	H	H	H	H	H	H	H	H	H	H	H	H	H	H	H	H
L	L	L	L	L	H	L	H	H	H	H	H	H	H	H	H	H	H	H	H	H	H
L	L	L	L	H	H	L	H	H	H	H	H	H	H	H	H	H	H	H	H	H	H
L	L	L	L	H	H	H	L	H	H	H	H	H	H	H	H	H	H	H	H	H	H
L	L	L	H	L	H	H	H	L	H	H	H	H	H	H	H	H	H	H	H	H	H
L	L	L	H	H	L	H	H	H	L	H	H	H	H	H	H	H	H	H	H	H	H
L	L	L	H	H	H	L	H	H	H	L	H	H	H	H	H	H	H	H	H	H	H
L	L	L	H	H	H	H	L	H	H	H	L	H	H	H	H	H	H	H	H	H	H
L	L	H	L	L	H	H	H	H	H	H	L	H	H	H	H	H	H	H	H	H	H
L	L	H	L	H	L	H	H	H	H	H	H	L	H	H	H	H	H	H	H	H	H
L	L	H	L	H	H	L	H	H	H	H	H	L	H	H	H	H	H	H	H	H	H
L	L	H	H	L	H	H	H	L	H	H	H	H	L	H	H	H	H	H	H	H	H
L	L	H	H	H	L	H	H	H	H	L	H	H	H	L	H	H	H	H	H	H	H
L	H	L	L	L	H	H	H	H	H	H	H	H	L	H	H	H	H	H	H	H	H
L	H	L	L	H	L	H	H	H	H	H	H	H	L	H	H	H	H	H	H	H	H
L	H	L	H	L	H	H	H	L	H	H	H	H	H	L	H	H	H	H	H	H	H
L	H	L	H	H	L	H	H	H	H	L	H	H	H	H	L	H	H	H	H	H	H
L	H	H	L	L	H	H	H	H	H	H	H	H	L	H	H	H	H	H	H	H	H
L	H	H	L	H	L	H	H	H	H	H	H	H	L	H	H	H	H	H	H	H	H
L	H	H	H	L	H	H	H	L	H	H	H	H	H	L	H	H	H	H	H	H	H
L	H	H	H	H	L	H	H	H	H	L	H	H	H	H	L	H	H	H	H	H	H
H	L	X	X	X	H	H	H	H	H	H	H	H	H	H	H	H	H	H	H	H	H
H	L	X	X	X	H	H	H	H	H	H	H	H	H	H	H	H	H	H	H	H	H
H	L	X	X	X	H	H	H	H	H	H	H	H	H	H	H	H	H	H	H	H	H
H	H	X	X	X	H	H	H	H	H	H	H	H	H	H	H	H	H	H	H	H	H
H	H	X	X	X	H	H	H	H	H	H	H	H	H	H	H	H	H	H	H	H	H

H = high level, L = low level, X = irrelevant

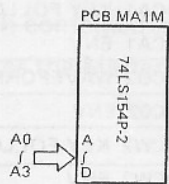
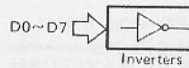

Combining the signals A0 ~ A3, Decoder 4 generates signals $\phi 17 \sim \phi 19$ and $\phi 1A \sim \phi 1D$ which set Latches 5 ~ 11.

For lighting the LED "NORMAL", MAIN CPU raises signal D0 which is inverted to "L" level.

Then, MAIN CPU generates clock signal $\phi 17$ from signals A0 ~ A3.

$\bar{D}0$ ("L") is set in Latch 5 dropping signal L70 "L".

The LED "NORMAL" is lit when its anode is connected to VDL2 (+5V).

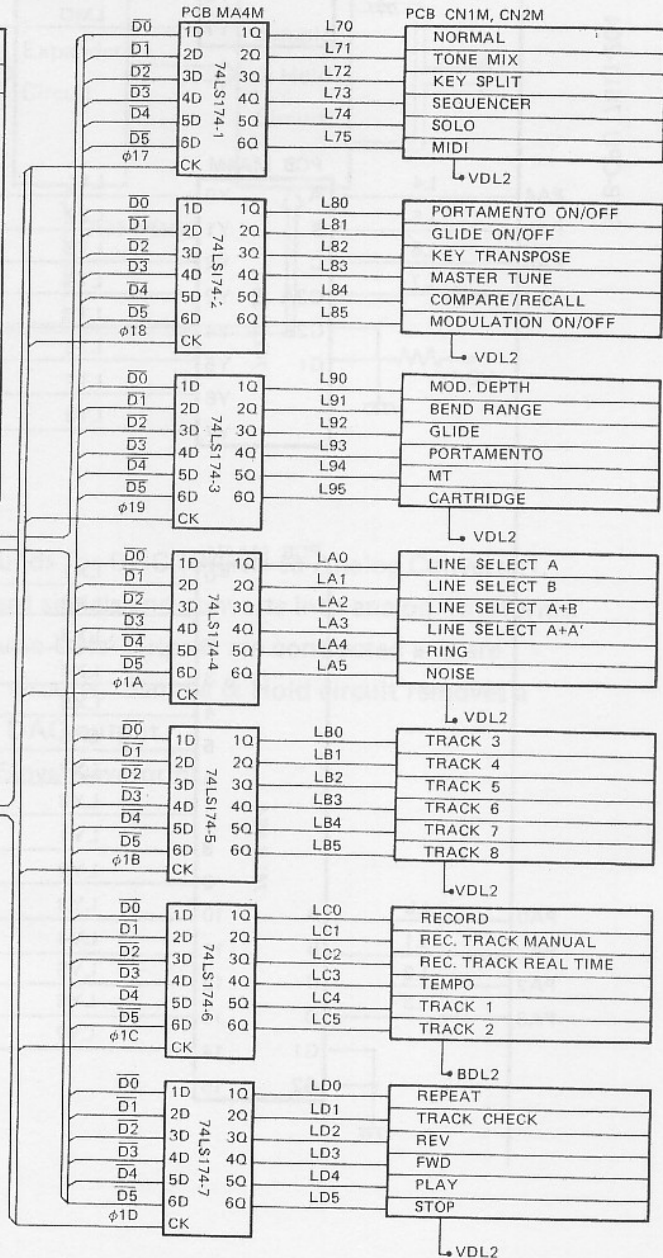

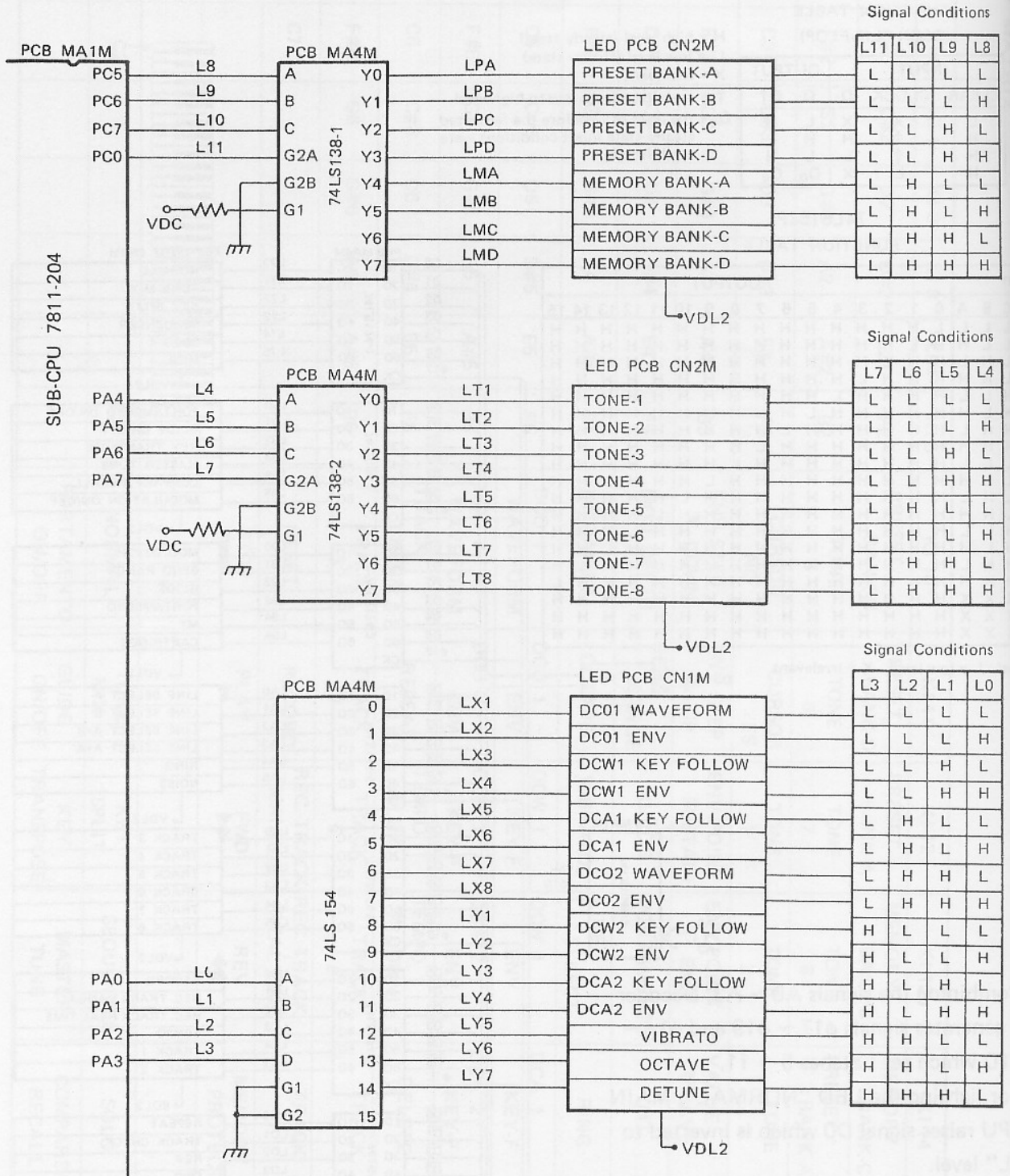

These LEDs are controlled by SUB-CPU.

For example, when SUB-CPU wishes to light the "PRESET BANK-A" LED, it drops all the signals L8 ~ L11. Y0 output of Decoder 5 drops to "L", causing the LED to be lit.

15. ANALOG CIRCUIT BLOCK DIAGRAM

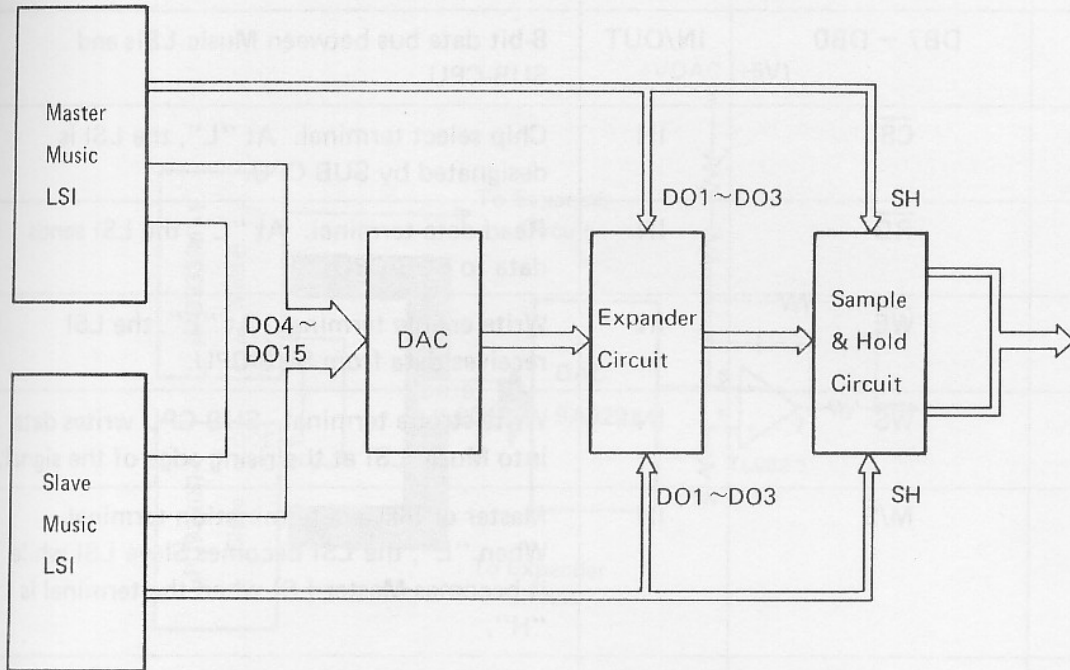

Master and Slave Music LSIs provide 12-bit digital sounds for DAC (Digital to Analog Converter). By means of time sharing, DAC mixes the two different signals and converts into analog waveforms. To obtain a wide dynamic range of the amplitude, Music LSIs' outputs are contracted and are reformed into a proper waveform shape by Expander circuits. Sample & Hold circuit removes a high frequency noise called as glitch contained in the DAC output. Sample & Hold Circuit also separates the Master and Slave waveforms.

16. MUSIC LSI (μ PD933)

PIN NO.	TERMINAL NAME	IN/OUT	FUNCTION
1 ~ 8	DB7 ~ DB0	IN/OUT	8-bit data bus between Music LSIs and SUB-CPU
9	$\overline{\text{CS}}$	IN	Chip select terminal. At "L", the LSI is designated by SUB-CPU.
10	$\overline{\text{RD}}$	IN	Read data terminal. At "L", the LSI sends data to SUB-CPU.
11	$\overline{\text{WE}}$	IN	Write enable terminal. At "L", the LSI receives data from SUB-CPU.
12	$\overline{\text{WS}}$	IN	Write strobe terminal. SUB-CPU writes data into Music LSI at the rising edge of the signal.
16	M/ $\overline{\text{S}}$	IN	Master or Slave determination terminal. When "L", the LSI becomes Slave LSI while it becomes Master LSI when the terminal is "H".
17	SYC	IN/OUT	Synchronous signal input/output terminal. The synchronous signal is sent from Master LSI to Slave LSI.
18	CLK	IN	4.48 MHz clock pulse input
21	RST	IN	Reset signal input. Normally the terminal stays "L". At power ON, the terminal rises to "H" level for a while and the internal circuits of the LSI are initialized.
22	DOE	IN/OUT	Data output enable terminal. At "H", digital sound signals are output from Master LSI while Slave LSI outputs sound signal at "L" level.
23	SH	OUT	40KHz sampling signal for Sample & Hold circuit
25 ~ 27	DO1 ~ DO3	OUT	Control signals for Expander circuit
28 ~ 39	DO4 ~ DO15	OUT	12-bit digital sound signals
40	VDD	IN	+5V power source

17. DAC (Digital to Analog Converter)

The two Music LSIs output different waveforms. When signal DOE is "H", Master LSI outputs a waveform while Slave LSI outputs a waveform at "L" level of DOE.

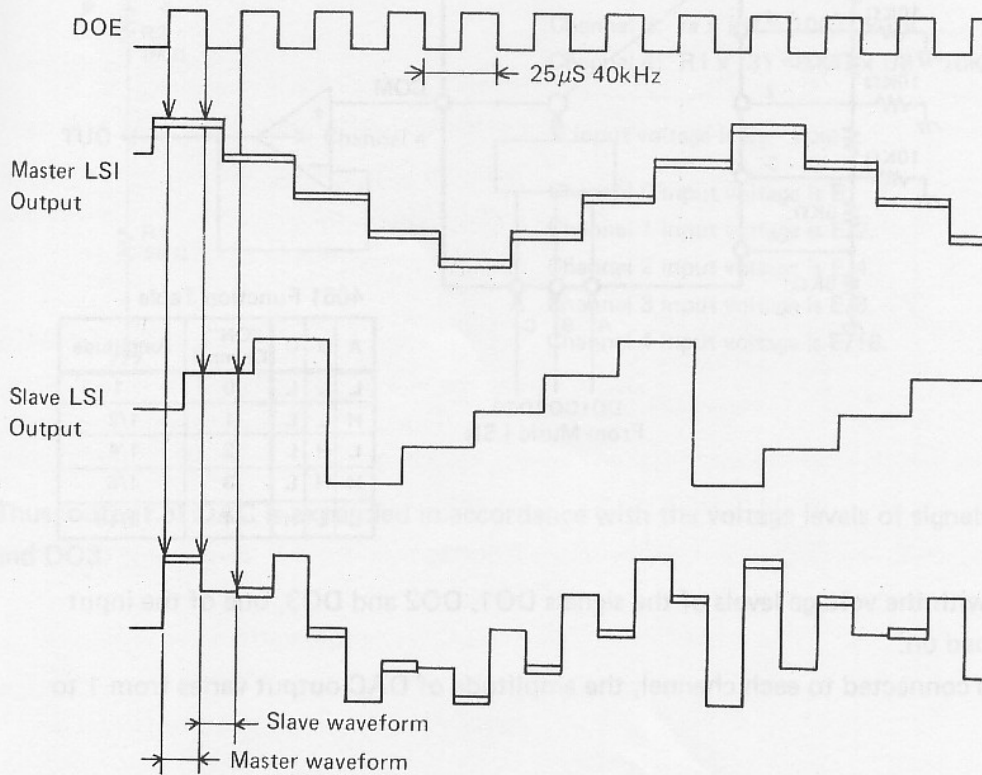
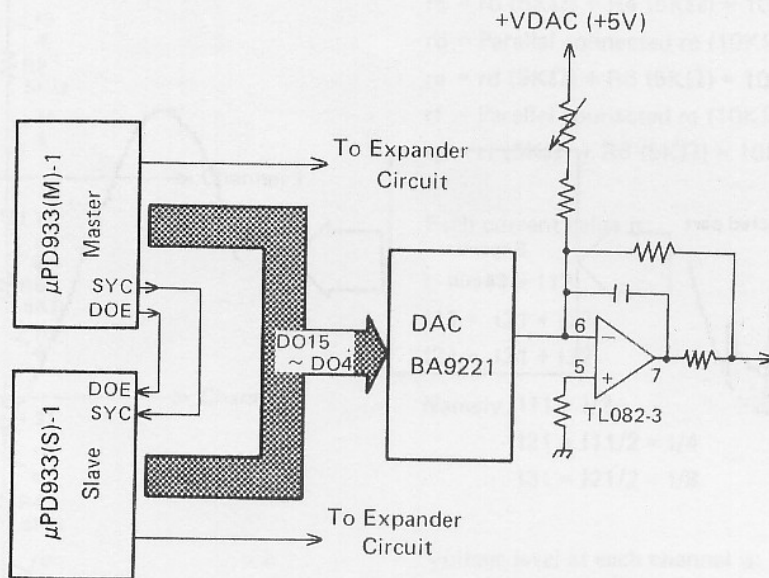

18. EXPANDER CIRCUIT

In order to extend the dynamic range of the melody signal, a part of DAC output waveform is contracted and expanded by Expander Circuit.

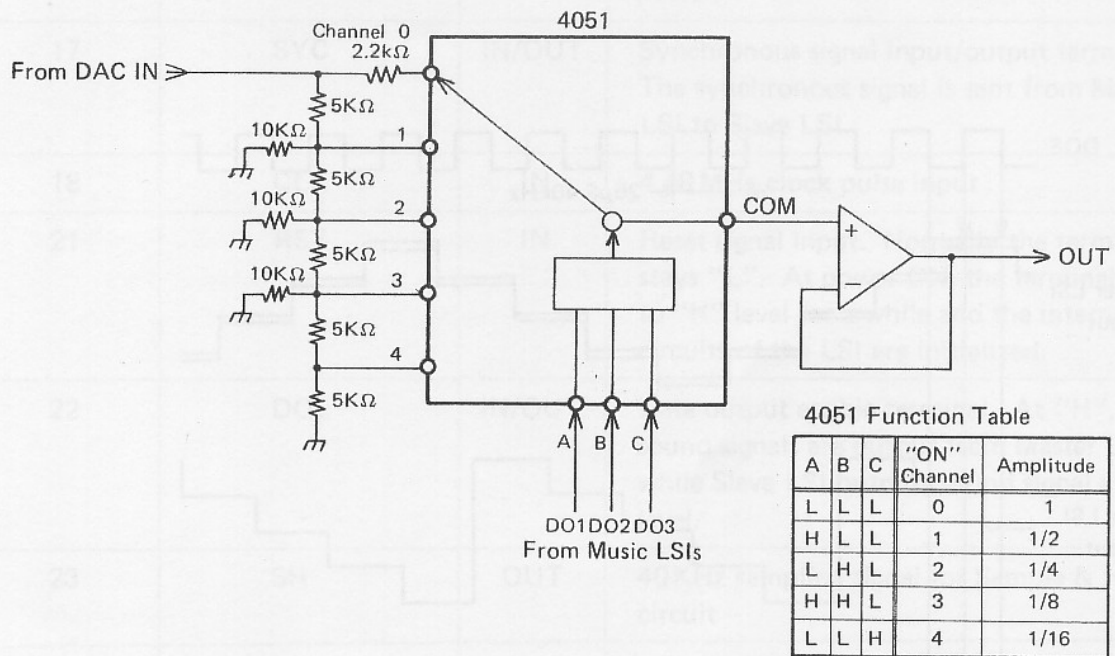
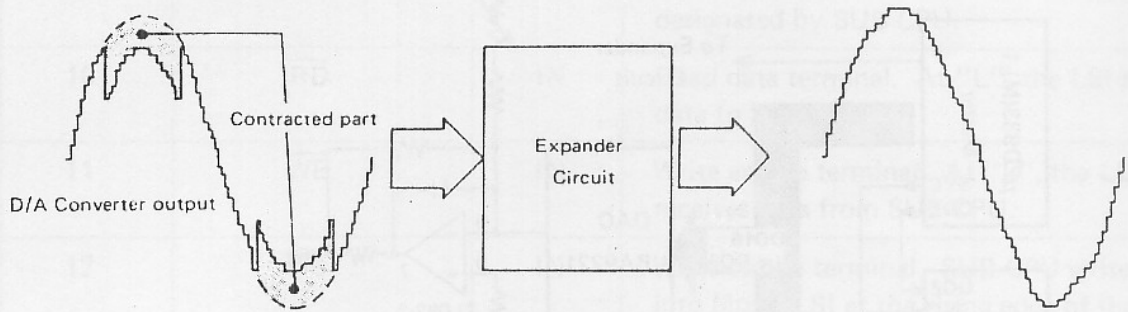

In accordance with the voltage levels of the signals DO1, DO2 and DO3, one of the input channels is turned on.

By the resistors connected to each channel, the amplitude of DAC output varies from 1 to 1/16.

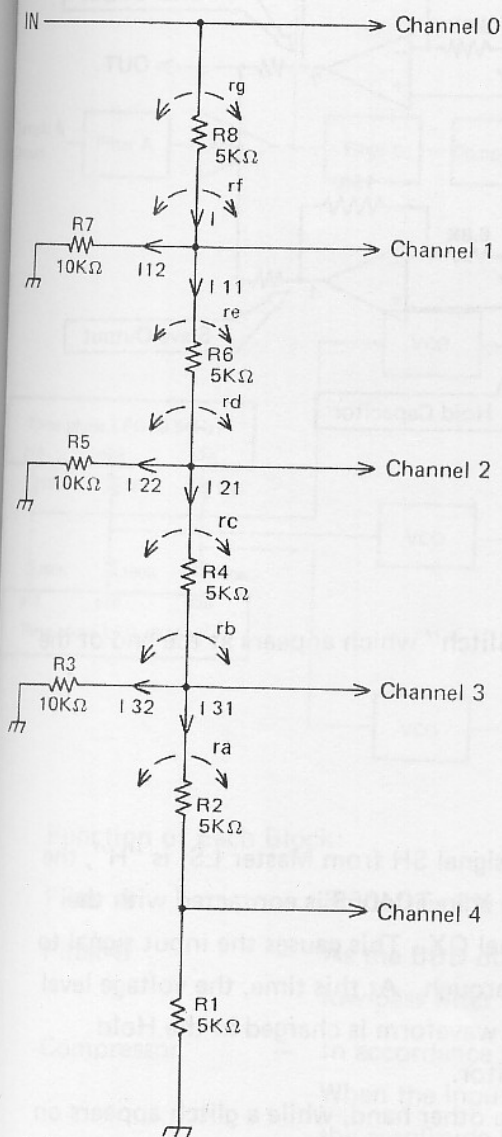

Combined resistances at each point are:

$$r_a = R_1 (5K\Omega) + R_2 (5K\Omega) = 10K\Omega$$

$$r_b = \text{Parallel connected } r_a (10K\Omega) \text{ and } R_3 (10K\Omega) = 5K\Omega$$

$$r_c = r_b (5K\Omega) + R_4 (5K\Omega) = 10K\Omega$$

$$r_d = \text{Parallel connected } r_c (10K\Omega) \text{ and } R_5 (10K\Omega) = 5K\Omega$$

$$r_e = r_d (5K\Omega) + R_6 (5K\Omega) = 10K\Omega$$

$$r_f = \text{Parallel connected } r_e (10K\Omega) \text{ and } R_7 (10K\Omega) = 5K\Omega$$

$$r_g = r_f (5K\Omega) + R_8 (5K\Omega) = 10K\Omega$$

Each current value is:

$$I = I_{11} + I_{12}$$

$$I_{11} = I_{21} + I_{22}$$

$$I_{21} = I_{31} + I_{32}$$

Namely, $I_{11} = I/2$

$$I_{21} = I_{11}/2 = I/4$$

$$I_{31} = I_{21}/2 = I/8$$

Voltage level at each channel is:

$$\text{Channel 0: } r_g \times I = 10K\Omega \times I$$

$$\text{Channel 1: } r_e \times I_{11} = 10K\Omega \times I/2$$

$$\text{Channel 2: } r_c \times I_{21} = 10K\Omega \times I/4$$

$$\text{Channel 3: } r_a \times I_{31} = 10K\Omega \times I/8$$

$$\text{Channel 4: } R_1 \times I_{31} = 5K\Omega \times I/8 = 10K \times I/16$$

If input voltage is E:

Channel 0 input voltage is E.

Channel 1 input voltage is E/2.

Channel 2 input voltage is E/4.

Channel 3 input voltage is E/8.

Channel 4 input voltage is E/16.

Thus, output of DAC is expanded in accordance with the voltage levels of signals DO1, DO2 and DO3.

19. SAMPLE & HOLD CIRCUIT

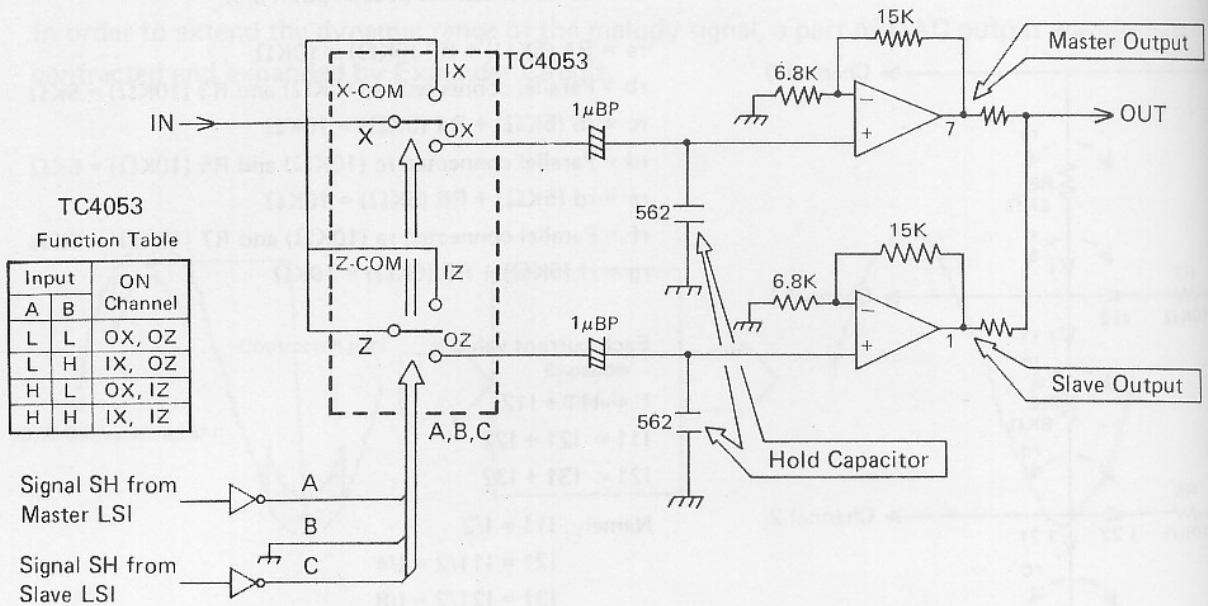

The block eliminates a high frequency noise called as "Glitch" which appears at the end of the stepped waveform.

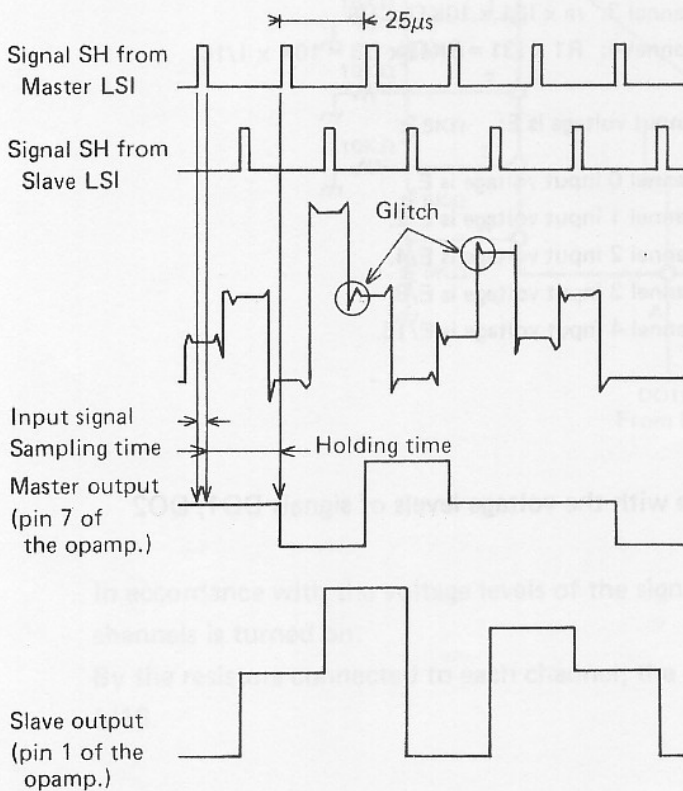

When signal SH from Master LSI is "H", the switch X in TC4053 is contacted with the terminal OX. This causes the input signal to pass through. At this time, the voltage level of the waveform is charged in the Hold Capacitor.

On the other hand, while a glitch appears on the waveform, the switch X is contacted with the terminal IX. This results in cutting off the glitch. Although no signal comes out of TC4053, the input of the opamp keeps the same voltage level by discharging of the Hold Capacitor.

Sampling or holding the slave waveform is performed by the same procedures using signal SH from Slave LSI and switch Z.

20. STEREO CHORUS CIRCUIT

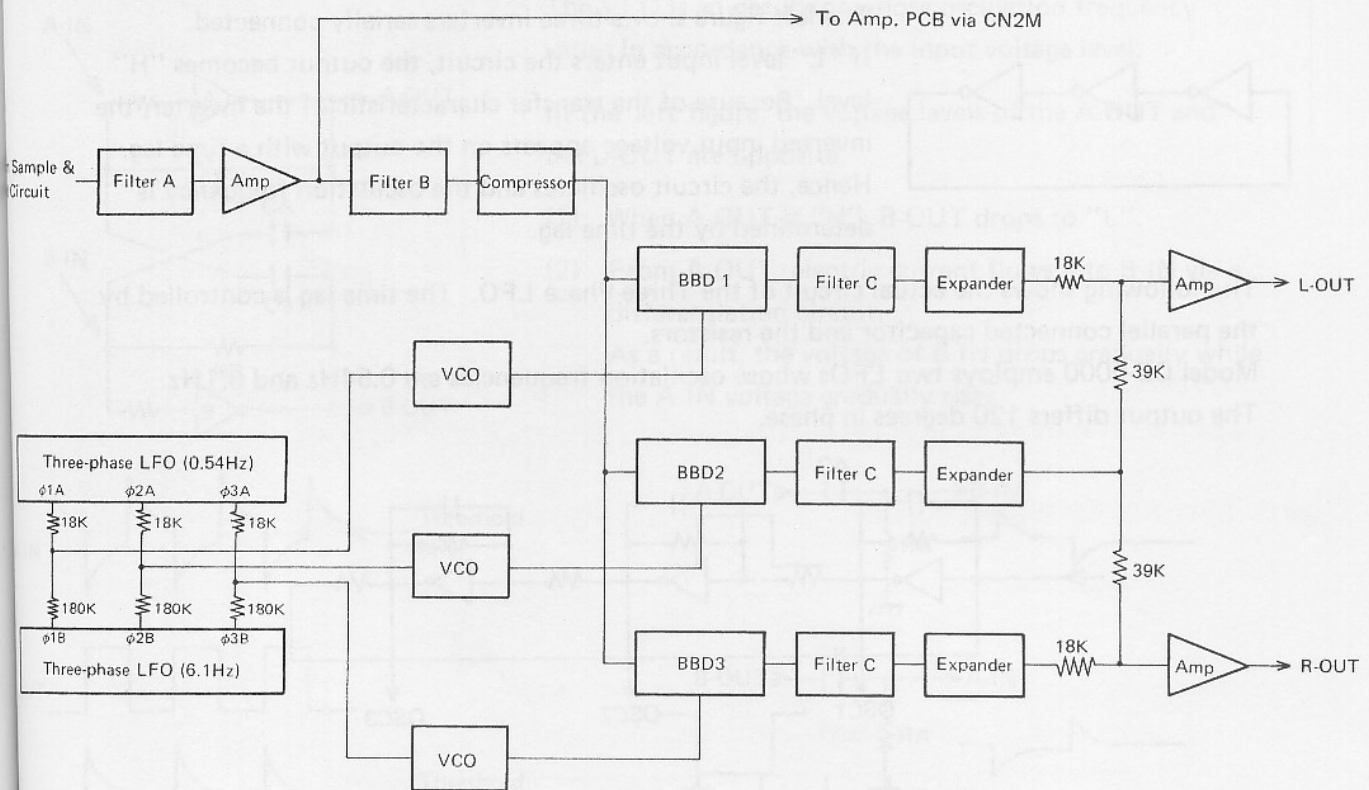

Function of Each Block:

- Filter A — Smooths the stepped waveform of Sample & Hold Circuit output signal.
- Filter B — As the BBD does not pass signals which exceed 20KHz, this block is a low-pass filter whose cutoff frequency is 20KHz.
- Compressor — In accordance with input signal level, this block controls the amplitude. When the input signal is small, the circuit amplifies the signal whereas the amplitude becomes smaller when the input is a large-level waveform. The block is used for reducing the noise.
- Three-Phase LFOs — Generates low-frequency triangle signals of 0.54Hz and 6.1Hz. The three outputs differ 120 degrees in phase.
- VCOs — Voltage Controlled Oscillator which generates the clock pulses for the BBDs. Their oscillation frequencies vary in accordance with the input voltage level.
- BBDs — Bucket Brigade Device. Stereo chorus effect is given by delaying the right or the left sound.
- Filter C — Since the output signal of the BBD carries a noise caused by clock pulses, the filter removes the noise.
- Expander — Functions contrary to the Compressor. This circuit is also used for reducing the noise.

20-1. Three-Phase LFO (Low Frequency Oscillator)

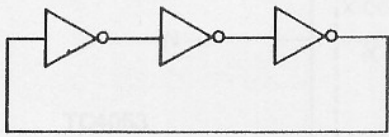

The left figure shows three inverters serially connected.

If "L" level input enters the circuit, the output becomes "H" level. Because of the transfer characteristic of the inverter, the inverted input voltage appears on the output with a time lag. Hence, the circuit oscillates and the oscillation frequency is determined by the time lag.

The following shows the actual circuit of the Three-Phase LFO. The time lag is controlled by the parallel connected capacitor and the resistors.

Model CZ-5000 employs two LFOs whose oscillation frequencies are 0.54Hz and 6.1 Hz.

The output differs 120 degrees in phase.

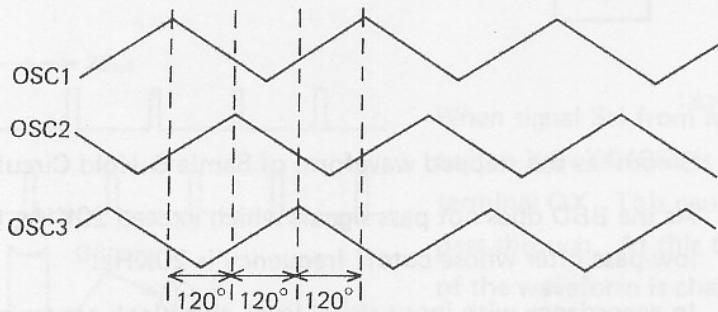
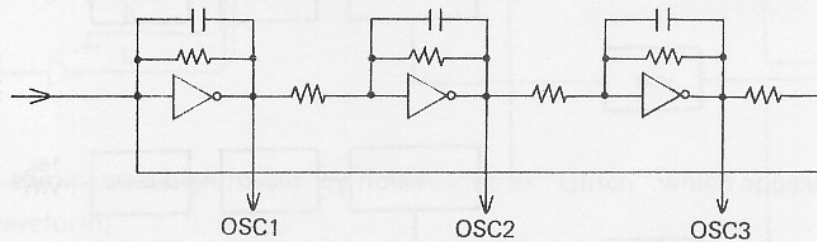

Both 0.54 Hz and 6.1 Hz triangle waveforms are mixed to give variational delays of the sound in the BBD.

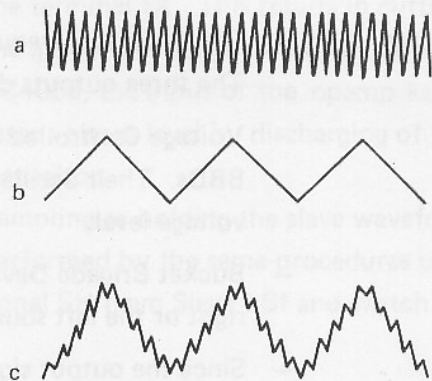
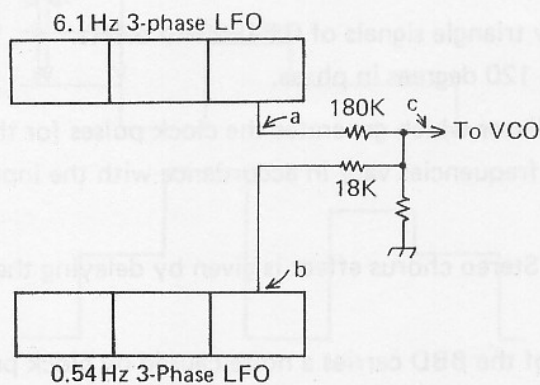

The 0.54 Hz and 6.1 Hz waveforms are mixed in the ratio of 10:1 as they pass through 18Kohm and 180Kohm resistors, respectively.

20-2. VCO (Voltage Controlled Oscillator)

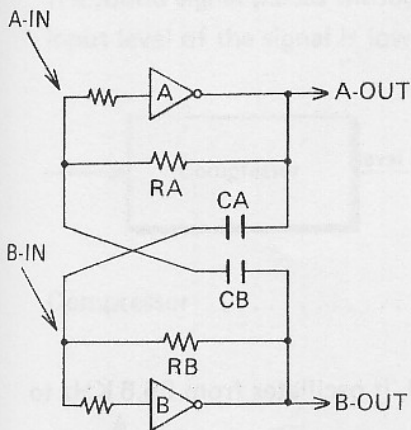

The VCO is an oscillator whose oscillation frequency varies in accordance with the input voltage level.

In the left figure, the voltage levels of the A-OUT and the B-OUT are opposite.

- (1) When A-OUT is "H", B-OUT drops to "L".
- (2) From A-OUT, electric current flows into B-IN via a differentiation circuit.

As a result, the voltage of B-IN drops gradually while the A-IN voltage gradually rises.

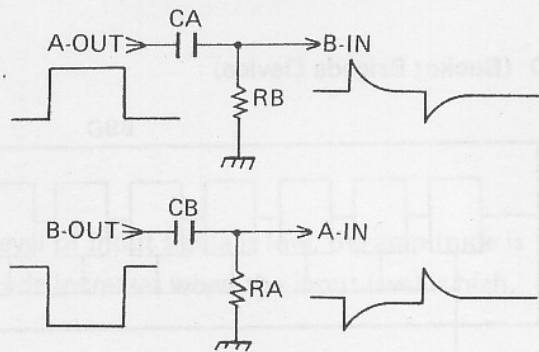
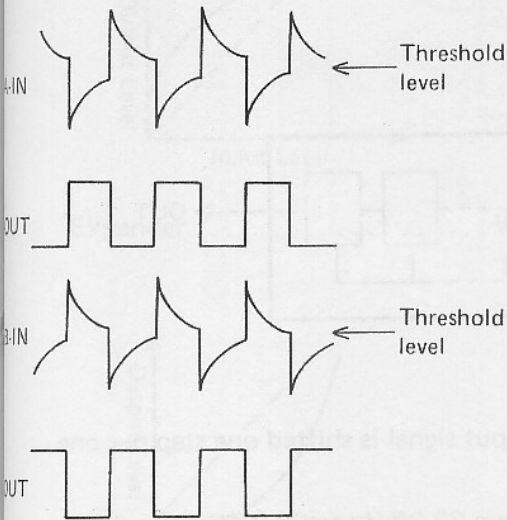

- (3) When B-IN becomes lower than the threshold level, B-OUT rises to "H".
- When A-IN becomes higher than the threshold level, A-OUT drops to "L".

- (4) The circuit oscillates repeating the above operations.

The following shows the actual circuit of VCO. When control terminal (A) is GND (zero volt), it takes approximately 15 microseconds for the differentiation circuit to reach the threshold voltage.

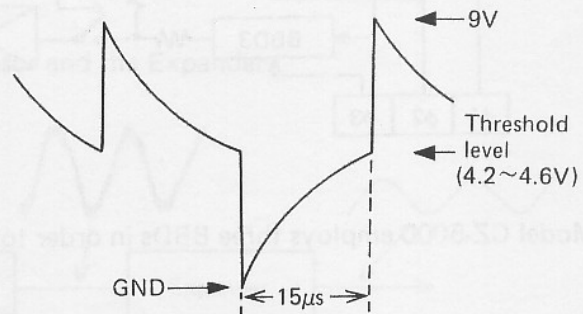
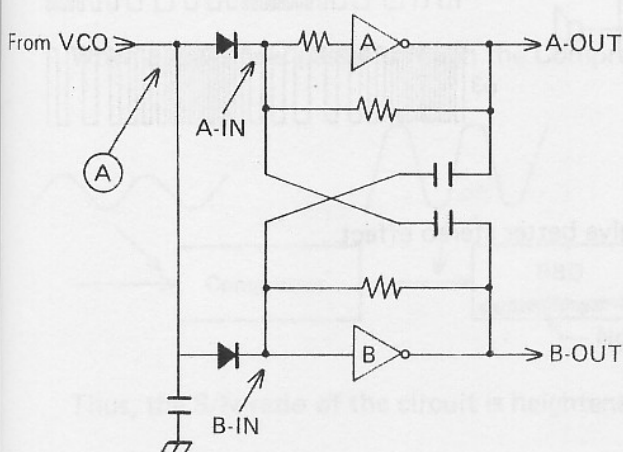

When the voltage of (A) is 2 volts, it takes only 9 microseconds to reach the threshold level.

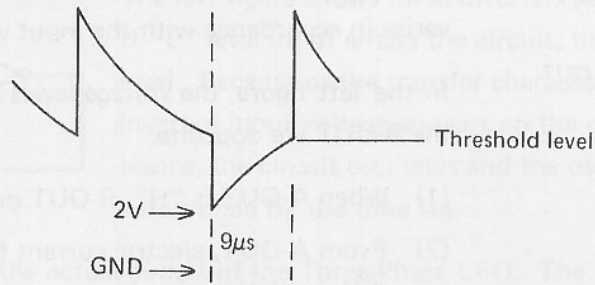

As VCO receives a triangle waveform from the Three-Phase LFO, it oscillates from 55.6 KHz to 33.3 KHz in accordance with the voltage level of LFO output.

20-3. BBD (Bucket Brigade Device)

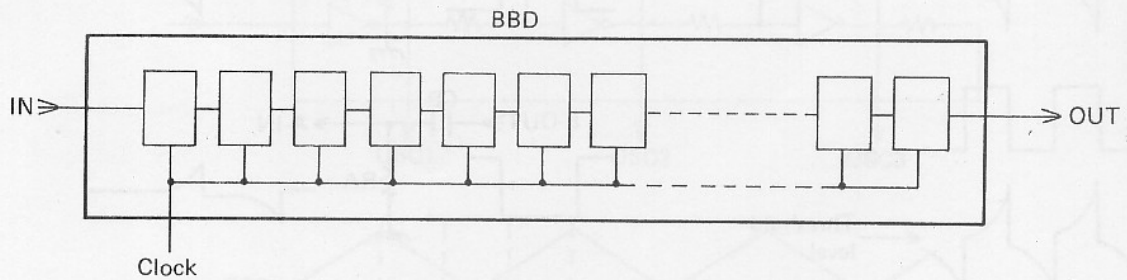

The BBD contains serial-connected delay elements. The input signal is shifted one step per one clock pulse.

The clock pulse is generated in the VCO, and as it varies from 33.3 KHz to 55.6 KHz, the delay time varies.

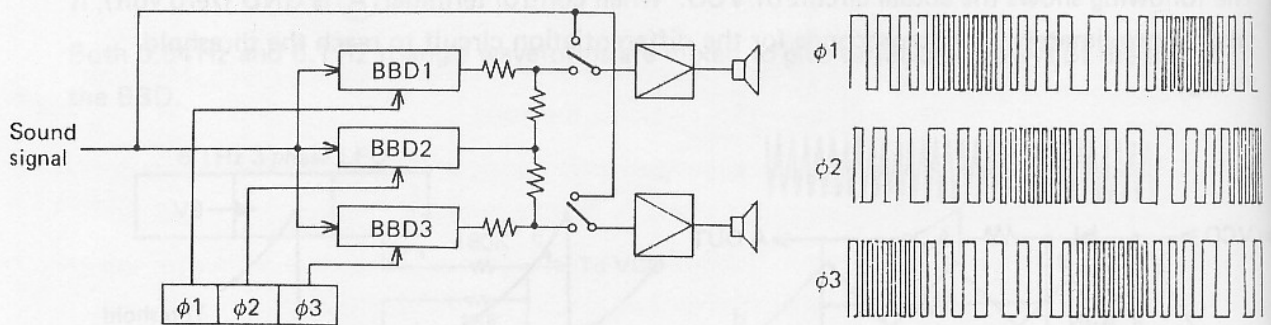

Model CZ-5000 employs three BBDs in order to give better stereo effect.

20-4. Compressor and Expander Circuits

If a sound signal passes through the BBD, a noise is carried on the signal especially when the input level of the signal is low.

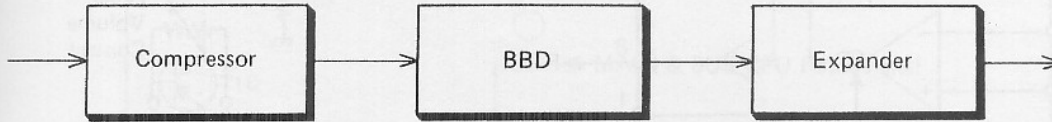

Compressor When the level of input signal is low, the amplitude is large.
If the input level is high, the amplitude decreases.

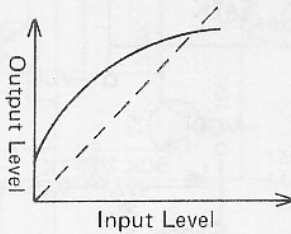

Expander When the level of input signal is low, the amplitude is small.
The amplitude increases when the input level is high.

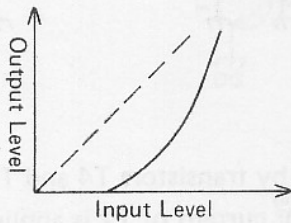

When a low signal does not pass through the Compressor and the Expander;

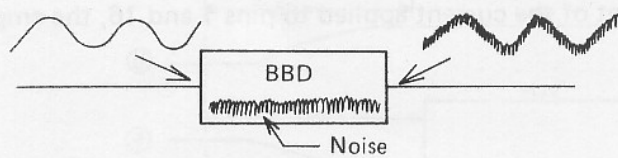

When a low signal passes through the Compressor and the Expander;

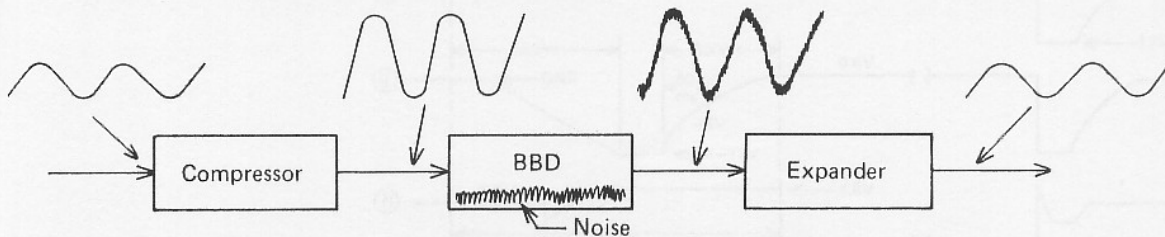

Thus, the S/N ratio of the circuit is heightened.

21. VOLUME CONTROL CIRCUIT

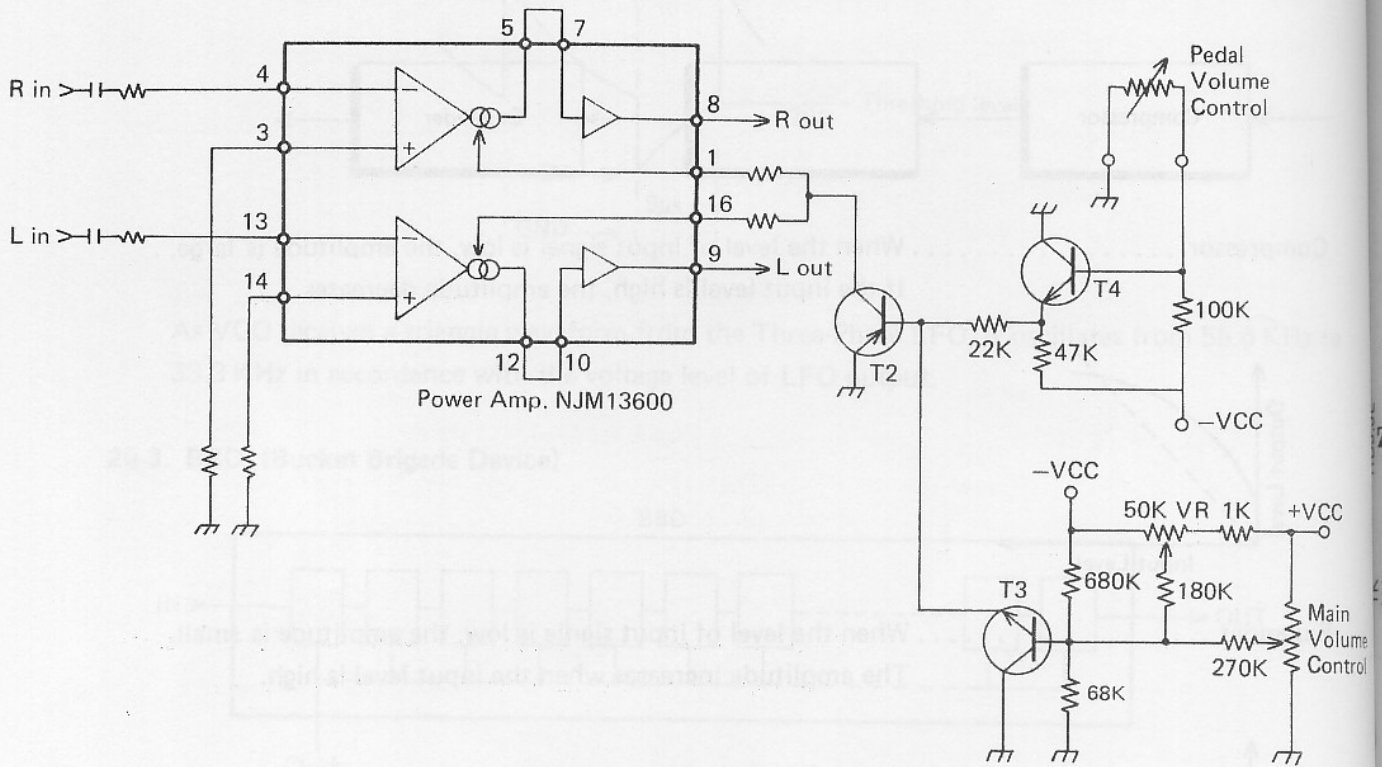

Electric current from pedal and main volume controls are amplified by transistors T4 and T3, respectively, and become the base current of transistor T2. Collector current of T2 is applied to NJM13600's control terminals.

NJM13600 is a power amplifier with control terminals.

In accordance with the amount of the current applied to pins 1 and 16, the amplitude of the amplifier varies.

22. RESET CIRCUIT

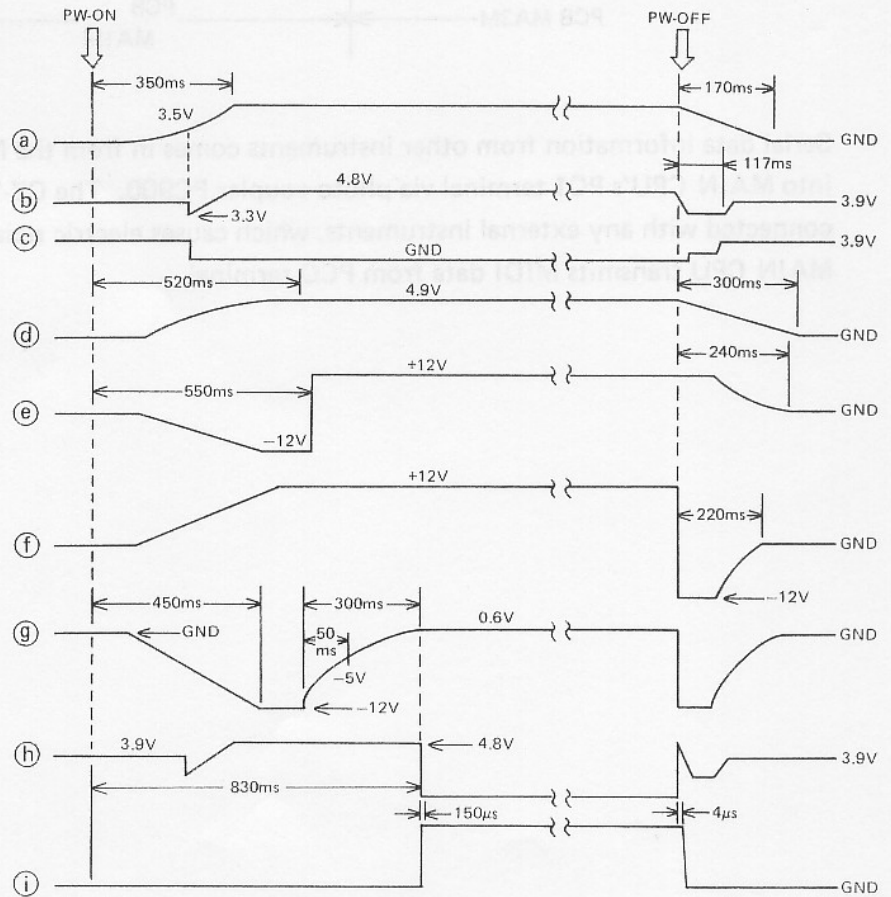
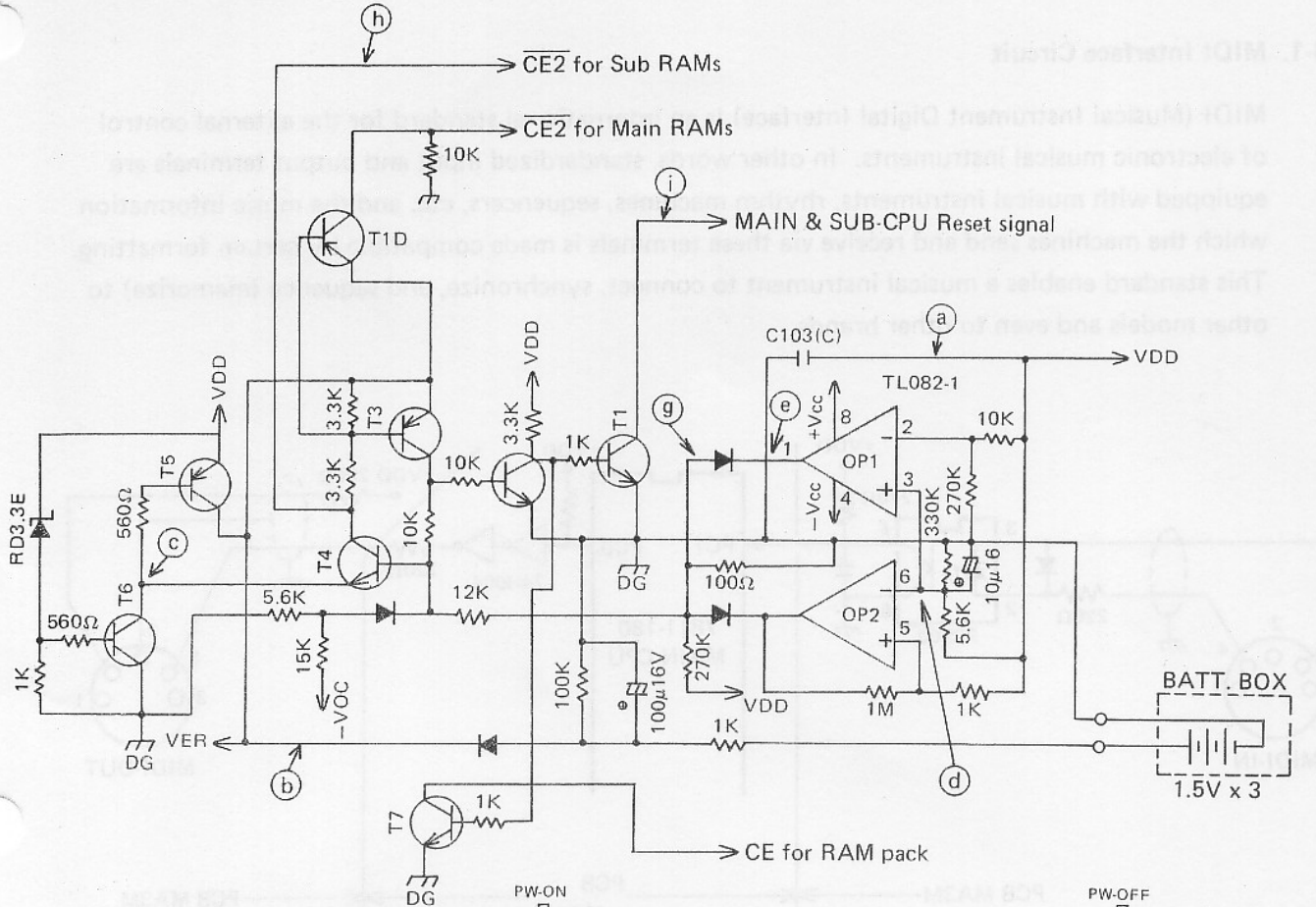

23. MIDI & MT INTERFACE CIRCUITS

23-1. MIDI Interface Circuit

MIDI (Musical Instrument Digital Interface) is an international standard for the external control of electronic musical instruments. In other words, standardized input and output terminals are equipped with musical instruments, rhythm machines, sequencers, etc. and the music information which the machines send and receive via these terminals is made compatible by certain formatting. This standard enables a musical instrument to connect, synchronize, and sequence (memorize) to other models and even to other brands.

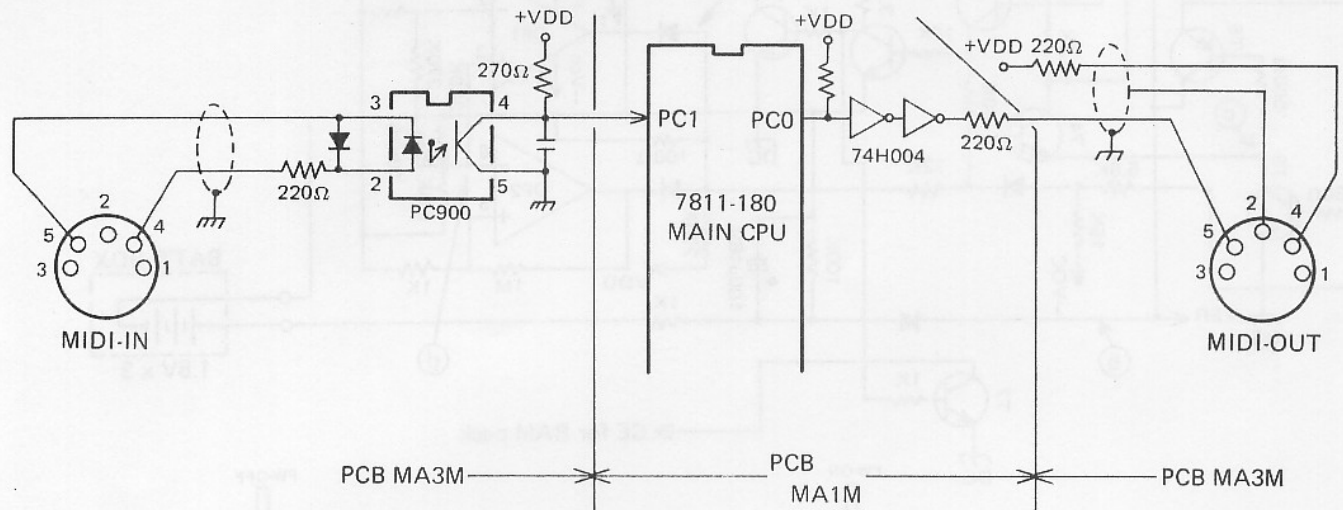

Serial data information from other instruments comes in from the MIDI-IN terminal and enters into MAIN CPU's PC1 terminal via photo coupler PC900. The CZ-5000 is not thus electrically connected with any external instruments; which causes electric noises to be cut off. MAIN CPU transmits MIDI data from PC0 terminal.

23-2. MT Interface Circuit

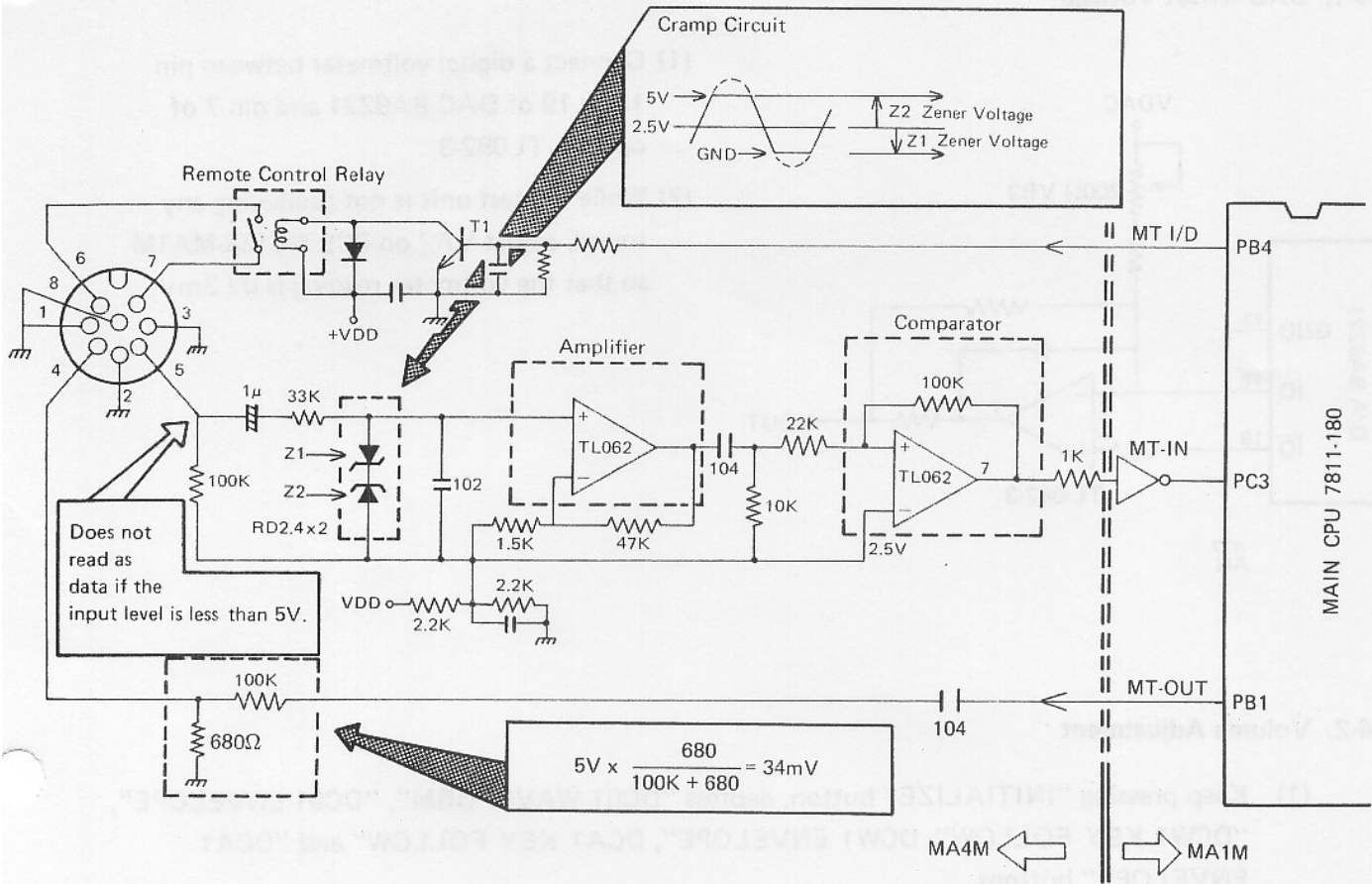

Digital data of 1 and 0 are recorded on magnetic tape as 2.4KHz and 1.2KHz sound, respectively. When data is read, a signal from a cassette tape player comes in from MT terminal pin 5.

As the voltage level varies depending on cassette tape players, the two zener diodes clamp the signal between 0 and +5 volts.

The cramped waveform is amplified by the first opamp. The second stage opamp is a comparator which examines whether the input voltage is higher or lower than 2.5V and outputs a square waveform to MAIN CPU's PC3 terminal.

As 5 volts of MAIN CPU's PB1 terminal is too high for a cassette tape recorder, it is dropped to 34 millivolts by the 100Kohm and 680ohm resistors.

Signal PB4 from MAIN CPU turns on and off the remote control relay which controls the motor in a cassette tape player.

24. ADJUSTMENT

24-1. DAC Offset Voltage

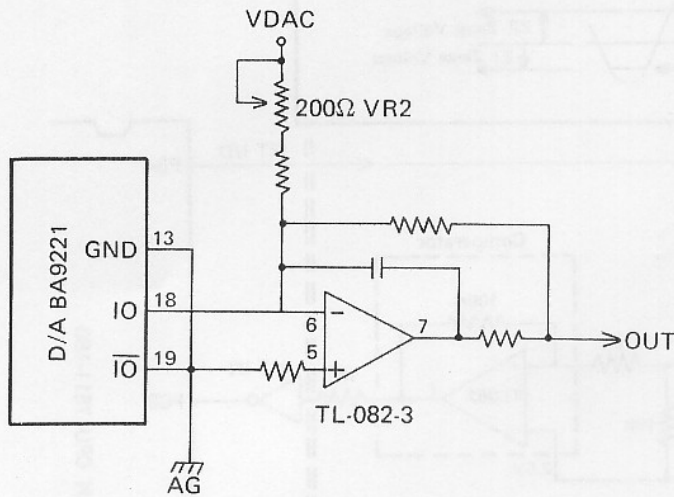

- (1) Connect a digital voltmeter between pin 13 or 19 of DAC BA9221 and pin 7 of opamp TL082-3.
- (2) While the test unit is not producing any sound, adjust VR2 on PCB M5153-MA1M so that the voltmeter reading is $0 \pm 3\text{mV}$.

24-2. Volume Adjustment

- (1) Keep pressing "INITIALIZE" button, depress "DC01 WAVEFORM", "DC01 ENVELOPE", "DCW1 KEY FOLLOW", "DCW1 ENVELOPE", "DCA1 KEY FOLLOW" and "DCA1 ENVELOPE" buttons.
- (2) Depress "DCW1 ENVELOPE" and then "END" buttons.
- (3) Choose 1+1' by "LINE SELECT" button.
- (4) Set the volume control to its maximum and the stereo chorus volume to its minimum.
- (5) Connect a digital voltmeter between the ground and LINE-OUT terminal (either left or right output).
- (6) Depressing a key, adjust 50K VR on the PCB M5153-AS1M so that the voltmeter reading is 360mV (510mV when an oscilloscope is used for checking the voltage).

PARTS LIST

MPL-042

CZ-5000 (MX-153)

- Note:**
1. Prices and specifications are subject to change without notice.
 2. As for spare parts order/supply, refer to the separate publication, "GUIDEBOOK for Spare Parts Supply".

Item	Code No.	Part Name	Specification	Q'ty	*	Unit Price J.F. Yen (¥) (FOB: JAPAN)	R A N K
		1) MA1M PCB ASS'Y					
☆	2001 0525	C-MOSIC	MB64H173	1			A
☆	2001 1092	LSI	HN61364P-E39	1			A
	2002 0971	LSI	μPD933D	2			A
☆	2002 1128	LSI	μPD7811G-180	1			A
☆	2002 1136	LSI	μPD7811G-204	1			A
☆	2009 1235	LSI	HM6264LP-15	2			
	2100 3808	C-MOSIC	TC4053BP	1			A
	2100 3841	LSI (RAM)	TC5516AP	3			A
	2100 4029	C-MOSIC	TC4051BP	1			A
	2100 4472	C-MOSIC	TC74HCU04P	2			A
☆	2100 4642	C-MOSIC	TC53257P-1255	1			
	2110 3756	IC	SN74LS04N	1			A
	2111 2178	IC	SN74LS74AN	2			A
	2111 2194	IC	SN74LS138N	2			A
	2111 2283	IC	SN74LS08N	1			A
	2111 2496	IC	SN74LS174N	2			A
	2111 2615	IC	SN74LS05N	1			A
☆	2120 9341	IC	TL082	3			A
☆	2122 0221	D/A converter	BA9221	1			A
	2184 1014	IC	HD74LS154P	2			A
	2520 3194	Crystal oscillator	HC-18/U-8960kHz	1	10		B
☆	2520 3224	Crystal oscillator	HC-18/U-12MHz	1	10		B
	2720 2519	Module resistor	MS3329	1	10		C
	2720 2811	Module resistor	MS4736	2	10		C
	2720 2837	Module resistor	MS3326	1	10		C
	2760 2177	Trimmer VR	V8K4-11B10K	1	10		B
☆	2760 2258	Trimmer VR	V8K4-11B200	1	10		B
☆	2805 6273	Electrolytic capacitor	SMC6.3VB-470(M)	1	10		C
	3500 3371	Connector 2P	IL-G-2P-S3T2-E	2	10		X
	3500 3428	Connector 9P	IL-G-9P-S3T2-E	2	10		X
	3500 7032	P.C. board connector	5229-13-CPB	1	10		X
	3500 7041	P.C. board connector	5229-17-CPB	1	10		X
☆	3500 7059	P.C. board connector	5229-23-CPB	1	10		X
	3500 7491	P.C. board connector	IL-G-14P-S3T2-E	1	10		X
	3500 7505	P.C. board connector	IL-G-6P-S3T2-E	2	10		X
☆	3500 8169	P.C. board connector	ZC-026	1	10		X

Note: ☆ — New part

Q'ty — Quantity used per unit

* — Minimum order/supply quantity

Rank A : Essential

B : Stock recommended

C : Others

X : No stock recommended

Item	Code No.	Part Name	Specification	Q'ty	*	Unit Price J.F. Yen (¥) (FOB: JAPAN)	R A N K
☆	3511 0933	P.C. board connector	5229-12CPB	1	10		X
	3730 7301	Parallel wire M153	2468-7-230	1	10		X
	2200 3721	Transistor	2SA933-SQ	5	10		B
	2220 1395	Transistor	2SC1740SQ	6	10		B
	2301 3002	Diode	DS-442	6	10		C
	2310 3265	Zener diode	RD5.6E(B2)	1	10		B
	2310 3338	Zener diode	RD3.3E(B2)	1	10		B
	2600 7313	Carbon film resistor	R-25-10K-J	10	10		C
	2600 9715	Carbon film resistor	R-25-100K-J	1	10		C
	2600 7712	Carbon film resistor	R-25-15K-J	3	10		C
	2600 5515	Carbon film resistor	R-25-1.8K-J	1	10		C
	2601 0918	Carbon film resistor	R-25-330K-J	1	10		C
	2600 6716	Carbon film resistor	R-25-5.6K-J	4	10		C
	2600 6911	Carbon film resistor	R-25-6.8K-J	5	10		C
	2600 2516	Carbon film resistor	R-25-100-J	2	10		C
	2600 3717	Carbon film resistor	R-25-330-J	1	10		C
	2600 4314	Carbon film resistor	R-25-560-J	2	10		C
	2600 4918	Carbon film resistor	R-25-1K-J	90	10		C
	2601 2112	Carbon film resistor	R-25-1M-J	3	10		C
	2600 5710	Carbon film resistor	R-25-2.2K-J	2	10		C
	2600 8115	Carbon film resistor	R-25-22K-J	1	10		C
	2600 3318	Carbon film resistor	R-25-220-J	2	10		C
	2600 6112	Carbon film resistor	R-25-3.3K-J	25	10		C
	2600 9316	Carbon film resistor	R-25-68K-J	1	10		C
	2600 7119	Carbon film resistor	R-25-8.2K-J	1	10		C
	2600 4713	Carbon film resistor	R-25-820-J	2	10		C
	2600 1714	Carbon film resistor	R-25-47-J	1	10		C
	2600 7518	Carbon film resistor	R-25-12K-J	2	10		C
	2600 9910	Carbon film resistor	R-25-120K-J	2	10		C
	2601 0713	Carbon film resistor	R-25-270K-J	2	10		C
	2600 6511	Carbon film resistor	R-25-4.7K-J	1	10		C
	2600 5914	Carbon film resistor	R-25-2.7K-J	1	10		C
	2600 5116	Carbon film resistor	R-25-1.2K-J	1	10		C
	2600 4110	Carbon film resistor	R-25-470-J	1	10		C
	2600 0912	Carbon film resistor	R-25-22-J	1	10		C
☆	0002 8722	Carbon film resistor	R-25-5K-J	5	10		C
	2808 0387	Electrolytic capacitor	SMC50VB-2R2(M)	1	10		C
	2805 5064	Electrolytic capacitor	SMC50VB-R1(M)-T	3	10		C

Note: ☆ - New part

Q'ty - Quantity used per unit

* - Minimum order/supply quantity

Rank A: Essential

B: Stock recommended

C: Others

X: No stock recommended

Item	Code No.	Part Name	Specification	Q'ty	*	Unit Price J.F. Yen (¥) (FOB: JAPAN)	R A N K
☆	2804 5051	Electrolytic capacitor	16RE10	1	10		C
☆	0002 8720	Electrolytic capacitor	6.3RE2-470	4	10		C
	2808 1014	Electrolytic capacitor	SMC50VB-1MBP-T	3	10		C
	2805 6389	Electrolytic capacitor	SMC16VB-10(M)	7	10		C
	2808 1111	Electrolytic capacitor	SMC16VB-100(M)-T	1	10		C
	2808 1138	Electrolytic capacitor	SMC16VB-33(M)-T	1	10		C
	2818 0055	Ceramic capacitor	HE40SJYB221K	8	10		C
	2818 6191	Ceramic capacitor	HE40SJSL220K	1	10		C
	2818 2040	Ceramic capacitor	HE70SJYF103Z	25	10		C
☆	2818 2414	Ceramic capacitor	RT-HE40TKSL- 560K-T	1	10		C
	2818 3097	Ceramic capacitor	HE40SJCH220J	2	10		C
☆	0002 8705	Ceramic capacitor	HE11SJSL681K	1	10		
	2818 6045	Ceramic capacitor	HE40SJSL680K	1	10		C
	2820 3080	TF capacitor	ECQ-V1H-104-JZ	2	10		C
☆	0002 8709	TF capacitor	ECQ-B1H333KHW	1	10		C
☆	0002 8710	TF capacitor	ECQ-B1H562KHW	2	10		C
☆	4307 3320	PCB-M5153-MA1M	M1658-1	1			X
		2) MA2M PCB ASS'Y					
☆	2002 1144	IC	μPC1571C	2			A
	2100 3662	MOS IC	TC4069μBP	3			A
	2100 7692	MOS IC	MN3209	3			A
	2121 0013	OP AMP	NJM4558DD	3			A
	2808 0298	Electrolytic capacitor	SMC16VB-470(M)	1	10		C
	3500 3428	Connector 9P	IL-G-9P-S3T2-E	1			X
☆	3500 8177	6P connector M153A	IL-6P-10-M153	1			X
	3841 0661	Low pass filter	LPF-M152-17K	1			B
	2220 1395	Transistor	2SC1740SQ	4	10		B
	2301 3002	Diode	DS-442	10	10		C
	2600 7313	Carbon film resistor	R-25-10K-J	6	10		C
	2600 7712	Carbon film resistor	R-25-15K-J	5	10		C
	2600 7917	Carbon film resistor	R-25-18K-J	5	10		C
	2600 8514	Carbon film resistor	R-25-33K-J	6	10		C
	2600 8719	Carbon film resistor	R-25-39K-J	2	10		C
	2600 9111	Carbon film resistor	R-25-56K-J	4	10		C
	2600 4918	Carbon film resistor	R-25-1K-J	9	10		C
	2601 0314	Carbon film resistor	R-25-180K-J	6	10		C
	2600 5710	Carbon film resistor	R-25-2.2K-J	1	10		C

Note: ☆ — New part

Q'ty — Quantity used per unit

* — Minimum order/supply quantity

Rank A: Essential

B: Stock recommended

C: Others

X: No stock recommended

Item	Code No.	Part Name	Specification	Q'ty	*	Unit Price J.F. Yen (¥) (FOB: JAPAN)	R A N K
	2600 8115	Carbon film resistor	R-25-22K-J	15	10		C
	2601 0519	Carbon film resistor	R-25-220K-J	3	10		C
	2600 8310	Carbon film resistor	R-25-27K-J	5	10		C
	2600 6112	Carbon film resistor	R-25-3.3K-J	2	10		C
	2601 1116	Carbon film resistor	R-25-390K-J	1	10		C
	2600 8913	Carbon film resistor	R-25-47K-J	6	10		C
	2600 9316	Carbon film resistor	R-25-68K-J	3	10		C
	2600 9910	Carbon film resistor	R-25-120K-J	1	10		C
	2601 0110	Carbon film resistor	R-25-150K-J	9	10		C
	2601 1515	Carbon film resistor	R-25-560K-J	3	10		C
	2600 6511	Carbon film resistor	R-25-4.7K-J	3	10		C
	2600 9511	Carbon film resistor	R-25-82K-J	1	10		C
	2601 6398	Carbon film resistor	R-25-6.8M-J	1	10		C
	2805 5013	Electrolytic capacitor	SMC16VB-47(M)-T	2	10		C
	2804 9013	Electrolytic capacitor	50RNBBP1	6	10		C
	2804 5051	Electrolytic capacitor	16RE10	1	10		C
	2808 1014	Electrolytic capacitor	SMC50VB-1MBP-T	2	10		C
	2808 0310	Electrolytic capacitor	SMC50VB-1(M)	7	10		C
	2808 1049	Electrolytic capacitor	SMC50VB-3R3(M)	4	10		C
	2805 6389	Electrolytic capacitor	SMC16VB-10(M)	8	10		C
	2805 6117	Electrolytic capacitor	SMC25VB-10(M)	6	10		C
	2818 0110	Ceramic capacitor	HE50SJYB102K	3	10		C
	2818 2040	Ceramic capacitor	HE70SJYF103Z	9	10		C
☆	0002 8706	Ceramic capacitor	HE60SJSL181K	3	10		C
	2819 0280	Ceramic capacitor	HE60SJSL151K	2	10		C
	2818 3259	Ceramic capacitor	HE11SJCH221J	6	10		C
	2818 6053	Ceramic capacitor	HE50SJSL101K	2	10		C
☆	0002 8711	TF capacitor	ECQ-B1H102KHW	3	10		C
☆	0002 8708	TF capacitor	ECQ-B1H103KHW	1	10		C
☆	0002 8712	TF capacitor	ECQ-B1H222KHW	1	10		C
☆	0002 8713	Mylar capacitor	ECQ-B1H822KHW	3	10		C
☆	0002 8714	TF capacitor	ECQ-B1H123KHW	3	10		C
☆	0002 8715	TF capacitor	ECQ-B1H183KHW	1	10		C
☆	0002 8716	Mylar capacitor	ECQ-B1H182KHW	2	10		C
☆	4307 3310	PCB-M5153-MA2M	M1659-1	1	10		X

Note: ☆ — New part
Q'ty — Quantity used per unit
* — Minimum order/supply quantity

Rank A: Essential
B: Stock recommended
C: Others
X: No stock recommended

Item	Code No.	Part Name	Specification	Q'ty	*	Unit Price J.F. Yen (¥) (FOB: JAPAN)	R A N K
		3) MA3M PCB ASS'Y					
	2120 9279	IC	TL062CP	1			A
	2400 5062	Photo coupler	PC900	1			A
☆	3120 6073	Relay	FBR211AD005-M	1			B
	3420 2338	Slide switch	SSY322	1			B
☆	3500 8266	9P connector M153A	IL-9P-35-M153	1			X
	3612 0541	DINJACK	TCS4650-01-1211	2			C
☆	3612 0622	Din connector	TCS4680-01-1211	1			C
	2220 1395	Transistor	2SC1740SQ	1	10		A
	2301 3002	Diode	DS-442	2	10		C
	2310 4644	Zenar diode	RD2.4EB	2	10		B
☆	2600 7318	Carbon film resistor	R-25-10K-J	2	10		C
	2600 9715	Carbon film resistor	R-25-100K-J	3	10		C
	2600 5311	Carbon film resistor	R-25-1.5K-J	1	10		C
	2600 8514	Carbon film resistor	R-25-33K-J	1	10		C
	2600 4918	Carbon film resistor	R-25-1K-J	2	10		C
	2600 5710	Carbon film resistor	R-25-2.2K-J	3	10		C
	2600 8115	Carbon film resistor	R-25-22K-J	1	10		C
	2600 3318	Carbon film resistor	R-25-220-J	1	10		C
	2600 8913	Carbon film resistor	R-25-47K-J	1	10		C
	2600 3512	Carbon film resistor	R-25-270-J	1	10		C
	2600 4519	Carbon film resistor	R-25-680-J	1	10		C
	2808 1014	Electrolytic capacitor	SMC50VB-1MBP-T	1	10		C
	2808 1138	Electrolytic capacitor	SMC16VB-33(M)-T	1	10		C
	2818 0110	Ceramic capacitor	HE50SJYB102K	1	10		C
	2818 2040	Ceramic capacitor	HE70SJYF103Z	2	10		C
	2818 6053	Ceramic capacitor	HE50SJSL101K	1	10		C
	2820 3080	TF capacitor	ECQ-V1H-104-J	2	10		C
☆	4307 3280	PCB-M5153-MA3M	M1716-2	1			X
		4) MA4M PCB ASS'Y					
	2111 2194	IC	SN74LS138N	2			A
	2111 2496	IC	SN74LS174N	7			A
	2184 1014	IC	HD74LS154P	1			A
☆	3500 8223	3P connector M153B	IL-3P-40-M153	1			X
☆	3721 0465	PC joiner M153A	PCJ-UV-12-180	1			B
☆	3721 0473	PC joiner M153D	PCJ-UV-13-180	1			B

Note: ☆ - New part

Q'ty - Quantity used per unit

* - Minimum order/supply quantity

Rank A: Essential

B: Stock recommended

C: Others

X: No stock recommended

Item	Code No.	Part Name	Specification	Q'ty	*	Unit Price J.F. Yen (¥) (FOB: JAPAN)	R A N K
☆	3721 0481	PC joiner M153G	PCJ-JPSS-12-200	1			B
☆	3721 0490	PC joiner M153M	PCJ-JPSS-18-200	1			B
☆	3721 0503	PC joiner M153L	PCH-JPSS-20-330	1			B
☆	3721 0511	PC joiner M153H	PCJ-JPSS-27-175	1			B
	6002 0248	Joiner holder G545	P4260-1	2			X
	2600 4918	Carbon film resistor	R-25-1K-J	9	10		C
	2818 2040	Ceramic capacitor	HE70SJYF103Z	9	10		C
☆	4307 3250	PCB-M5153-MA4M	M1671-1	1			X
5) CN1M PCB ASS'Y							
☆	3410 1710	Push switch	KHC10902	46	10		B
☆	3721 0449	PC joiner M153E	PCJ-UV-23-180	1			B
☆	3721 0457	PC joiner M153J	PCJ-JPSS-15-30	1			B
	6230 2348	Joiner holder E71	E41620A-1	1			X
	2301 3002	Diode	DS-442	46	10		C
	2320 9811	LED	LN266RPT	45	10		B
	2600 3911	Carbon film resistor	R-25-390-J	31	10		C
☆	4307 3270	PCB-M5153-CN1M	M1660-1	1			X
6) CN2M PCB ASS'Y							
	2121 0013	OP amp	NJM4558DD	1			A
	2770 9605	Variable resistor	EWA-NF0X05B14	1	10		B
	2770 9761	Slide VR	EWA-NA1X05B54	1			B
☆	3410 1701	Push switch	KHC10902	36	10		B
☆	3500 8142	4P connector M153	IL-4P-40-M153	1			X
☆	3500 8185	9P connector M153B	IL-9P-32-M153	1			X
☆	3500 8193	5P connector M153B	IL-5P-24-M153	1			X
☆	3500 8231	3P connector M153A	IL-3P-30-M153	1			X
	2301 3002	Diode	DS-442	37	10		C
	2320 9811	LED	LN266RPT	27	10		B
	2600 7313	Carbon film resistor	R-25-10K-J	1	10		C
	2600 7712	Carbon film resistor	R-25-15K-J	5	10		C
	2600 7917	Carbon film resistor	R-25-18K-J	2	10		C
	2600 3911	Carbon film resistor	R-25-390-J	14	10		C
	2600 4918	Carbon film resistor	R-25-1K-J	2	10		C
	2601 0110	Carbon film resistor	R-25-150K-J	1	10		C
	2819 0280	Ceramic capacitor	HE60SJS151K	1	10		C
☆	4307 3220	PCB-M5153-CN2M	M1661-1	1			X

Note: ☆ — New part
Q'ty — Quantity used per unit
* — Minimum order/supply quantity

Rank A: Essential
B: Stock recommended
C: Others
X: No stock recommended

Item	Code No.	Part Name	Specification	Q'ty	*	Unit Price J.F. Yen (¥) (FOB: JAPAN)	R A N K
7) CN3M PCB ASS'Y							
☆	2320 9811	LED	LN266RPT	1	10		B
☆	3410 1710	Push switch	KHC10902	1	10		B
☆	3500 8207	P.C.B. connector	IL-G-4P-S3L2-E	1			X
☆	4307 3300	PCB-M5153-CN	M1661-2	1			X
8) AS1M PCB ASS'Y							
☆	2120 6571	IC	LA4170	1			A
☆	2120 8809	Power amp	NJM13600	1			A
	2121 0013	OP amp	NJM4558DD	1			A
	2520 3186	EMI filter	DSS710D223S12-22	1			C
	2760 2169	Trimmer VR	V8K4-11B50K	1			B
	2808 0298	Electrolytic capacitor	SMC16VB-470(M)	2	10		C
	2808 0336	Electrolytic capacitor	SMC6.3VB-1000(M)	1	10		C
☆	3120 1161	Relay	G2V-1002H	1			B
	3500 3398	Pin ass'y 3P	IL-G-3P-S3L2-E	1			X
	3500 3975	Pin ass'y 5P	IL-G-5P-S3L2-E	1			X
☆	3500 8240	5P connector M153A	IL-5P-56-M153	1			X
☆	3500 8258	2P connector M153A	IL-2P-40-M153	1			X
	3612 0584	Jack	YKB21-5012	2			B
	3612 0592	Jack	YKB21-5002	1			B
☆	3612 0631	Jack	YKB21-5014	2			B
	5430 0107	Nut	YKV11-0095	5	50		C
	6904 0450	Jack holder	M31362-1	1			X
	2200 3721	Transistor	2SA933-SQ	2	10		B
	2220 1395	Transistor	2SC1740SQ	3	10		B
	2301 3002	Diode	DS-442	3	10		C
	2600 7313	Carbon film resistor	R-25-10K-J	8	10		C
	2600 9715	Carbon film resistor	R-25-100K-J	4	10		C
	2600 7712	Carbon film resistor	R-25-15K-J	1	10		C
	2600 6911	Carbon film resistor	R-25-6.8K-J	2	10		C
	2600 4918	Carbon film resistor	R-25-1K-J	4	10		C
	2601 0314	Carbon film resistor	R-25-180K-J	1	10		C
	2600 8115	Carbon film resistor	R-25-22K-J	3	10		C
	2600 6112	Carbon film resistor	R-25-3.3K-J	5	10		C
	2600 1510	Carbon film resistor	R-25-39J	2	10		C
	2600 8913	Carbon film resistor	R-25-47K-J	1	10		C

Note: ☆ - New part

Q'ty - Quantity used per unit

* - Minimum order/supply quantity

Rank A: Essential

B: Stock recommended

C: Others

X: No stock recommended

Item	Code No.	Part Name	Specification	Q'ty	*	Unit Price J.F. Yen (¥) (FOB: JAPAN)	R A N K
	2600 7119	Carbon film resistor	R-25-8.2K-J	2	10		C
	2601 0713	Carbon film resistor	R-25-270K-J	1	10		C
	2600 5914	Carbon film resistor	R-25-2.7K-J	6	10		C
	2601 1710	Carbon film resistor	R-25-680K-J	1	10		C
	2600 4110	Carbon film resistor	R-25-470-J	4	10		C
☆	2805 5111	Electrolytic capacitor	SMC50VB-R22(M)-T	2	10		C
☆	2805 5161	Electrolytic capacitor	SMC16VB-10MBP-T	2	10		C
☆	0002 8717	Electrolytic capacitor	16RE2-220	1	10		C
☆	0002 8718	Electrolytic capacitor	16RE2-330	2	10		C
	2808 1014	Electrolytic capacitor	SMC50VB-1MBP-T	4	10		C
	2808 0310	Electrolytic capacitor	SMC50VB-1(M)	1	10		C
	2805 6389	Electrolytic capacitor	SMC16VB-10(M)	2	10		C
	2808 1111	Electrolytic capacitor	SMC16VB-100(M)-T	2	10		C
	2808 1138	Electrolytic capacitor	SMC16VB-33(M)-T	1	10		C
	2818 2040	Ceramic capacitor	HE70SJYF103Z	2	10		C
☆	0002 8708	TF capacitor	ECQ-B1H103KHW	2	10		C
☆	4307 3290	PCB-M5153-AS1M	M1716-1	1			X
9) PSI PCB ASS'Y							
	2818 2601	Ceramic capacitor	DE7150FZ103PVA1	2	10		C
	3020 2104	Noise filter	TF2317C-601Y2R5	1			C
	3440 5298	Power switch	SDLC-1P	1			B
	3640 2357	Fuse clip	UF-0033#01	2			X
	3670 1161	Receptacle	NC-174	1			C
☆	4307 1201	PCB-M558-PS1	M3933A-1	1			X
	6901 5580	Receptacle fixing plate	M4850-1	1			X
☆	6904 5910	Wire subass'y	M42187*1	1			X
10) PSZM PCB ASS'Y							
☆	2120 8884	IC	NJM78M15A	1			A
☆	2200 3721	Transistor	2SA933SQ	1	10		A
☆	2210 5205	Transistor	2SB632-(E, F)	1	10		A
☆	2210 7038	Transistor	2SB632E, F	1	10		A
☆	2220 1395	Transistor	2SC1740SQ	4			A
	2230 3554	Transistor	2SD313 (E, F)	2	10		A
	2300 9102	Diode	S2VB10	1	10		C
	2301 3002	Diode	DS442	1	10		C
	2310 3541	Zener diode	RD18EB2	1	10		B
	2310 3583	Zener diode	RD16EB2	1	10		B

Note: ☆ - New part

Q'ty - Quantity used per unit

* - Minimum order/supply quantity

Rank A: Essential

B: Stock recommended

C: Others

X: No stock recommended

Item	Code No.	Part Name	Specification	Q'ty	*	Unit Price J.F. Yen (¥) (FOB: JAPAN)	R A N K
	2310 4539	Zener diode	RD5.6EL2	2	10		B
☆	2310 5276	Zener diode	RD8.2EL2	1	10		B
☆	2310 7456	Zener diode	RD6.2EL1	1	10		B
	2330 1075	Diode	S4VB10	1	10		B
	2600 1315	Carbon film resistor	R-25-33-J	1	10		C
	2600 2516	Carbon film resistor	R-25-100-J	2	10		C
	2600 5116	Carbon film resistor	R-25-1.2K-J	1	10		C
	2600 5311	Carbon film resistor	R-25-1.5K-J	1	10		C
	2600 5515	Carbon film resistor	R-25-1.8K-J	1	10		C
	2600 5710	Carbon film resistor	R-25-2.2K-J	1	10		C
	2600 9715	Carbon film resistor	R-25-100K-J	1	10		C
	2601 2911	Carbon film resistor	R-25-10-J	1	10		C
	2620 4313	Carbon film resistor	R-50X-560-J	1	10		C
	2630 2510	Carbon film resistor	R-1W-100-J	1	10		C
	2631 3210	Carbon film resistor	R-1W-0.47-J	2	10		C
☆	2804 5841	Electrolytic capacitor	16RE2-4700	1	10		C
☆	2804 5859	Electrolytic capacitor	35RE2-1000	2	10		C
☆	2805 6273	Electrolytic capacitor	SMC6.3VB-470(M)	3	10		C
	2808 0271	Electrolytic capacitor	SMC10VB-220(M)	3	10		C
	2808 0280	Electrolytic capacitor	SMC25VB-220(M)	1	10		C
	2808 0298	Electrolytic capacitor	SMC16VB-470(M)	2	10		C
	2808 0310	Electrolytic capacitor	SMC50VB-1(M)	1	10		C
	3500 3355	Pin ass'y 3P	IL-G-3P-S3T2-E	1	10		X
☆	3500 7610	Pin ass'y 5P	IL-G-5P-S3T2-E	1	10		X
☆	3500 8215	9P connector M153C	IL-9P-70-M153	1			X
	3640 2357	Fuse clip	UF-0033#01	6	10		X
☆	4307 3260	PCB-M5153-PS2M	M2973-1	1			X
☆	6904 6380	Heat sink 153	M42191-1	1			X
☆	6904 6410	Heat sink	M42301-1	1			X
		11) IF PCB ASS'Y					
	3510 6481	P.C.B. connector	PS30PE-S4LT1- PN1**	1			X
☆	3720 8761	PC joiner	SMCD-26-140	1			B
	4307 2960	PCB-M4150-IF	M31576-1	1			X
	6002 0248	Joiner holder G545	P4260-1	1			X

Note: ☆ — New part
Q'ty — Quantity used per unit
* — Minimum order/supply quantity

Rank A: Essential
B: Stock recommended
C: Others
X: No stock recommended

Item	Code No.	Part Name	Specification	Q'ty	*	Unit Price J.F. Yen (¥) (FOB: JAPAN)	R A N K
12) KEY PCB ASS'Y							
	3720 9317	PC joiner M35J	PCJ-JPSS-6-22	2			B
☆	3721 0350	PC joiner M88H	PCJ-JPSS-3-29	1	10		B
☆	3721 0422	PC joiner M153K	PCJ-UV-17-130	1			B
☆	3721 0431	PC joiner M153Q	PCJ-JPSS-4-29	1			B
	2301 3002	Diode	DS-442	61	10		C
☆	4307 3190	PCB-M49K-KY3M	M21030-1	1			X
☆	4307 3230	PCB-M61K-KY2M	M21032-1	1			X
☆	4307 3240	PCB-M61K-KY1M	M21031-1	1			X
13) POWER SUPPLY ASS'Y							
☆	3000 5422	Power transformer	TE-153-1M1	1			B
☆	3600 1186	Voltage selector	ESE-371	1			C
☆	6904 5910	Wire subass'y	M42187*1	1			X
14) LCD UNIT							
	3330 7544	LCD unit	LM550L	1			A
	3500 7903	14P connector M152	IL-14P25-M152	1			X
	6911 5370	LCD holder	M31485-1	1			B
15) FUSE							
☆	3631 1061	UL time lag fuse	(S) T-2A (Scandinavian countries)	1	10		A
☆	3631 1029	UL time lag fuse	(S) T-0.5A (Scandinavian countries)		10		A
☆	3631 1011	UL time lag fuse	(S) T-0.315A (Scandinavian countries)		10		A
	3631 0014	UL time lag fuse	UL-TSC-2A (Other countries)	1	10		A
	3631 0073	UL time lag fuse	UL-TSC-0.5A (Other countries)	2	10		A
	3631 2033	UL time lag fuse	MT4-1A (Other countries)	1	10		A
16) KEYBOARD ASS'Y							
☆	6904 5160	KB spring A	M42123-1	61	10		C
1☆	6904 5180	Key A	M31565-1	5			C
2☆	6904 5190	Key BE	M31566-1	10			C
3☆	6904 5200	Key CF	M31567-1	10			C





Note: ☆ — New part
Q'ty — Quantity used per unit
* — Minimum order/supply quantity

Rank A: Essential
B: Stock recommended
C: Others
X: No stock recommended

Item	Code No.	Part Name	Specification	Q'ty	*	Unit Price J.F. Yen (¥) (FOB: JAPAN)	R A N K
4 ☆	3904 5210	Key D	M31568-1	5			C
5 ☆	6904 5220	Key G	M31569-1	5			C
6 ☆	6904 5230	Key S	M31570-1	1			C
7 ☆	6904 5240	Black key	M31571-1	25			C
8 ☆	6904 6350	Key stopper 61A	M42126-1	1			C
9 ☆	6904 6360	Upper case stopper	M42130-1	1			C
10 ☆	6901 6161	S felt 61C	M4925A-1	1			X
11 ☆	6904 5280	Rubber switch G	M31553-1	4			B
12 ☆	6904 5290	Rubber switch H	M31554-1	1			B
13 ☆	6904 5301	KB guide C	M31630A-1	4			X
14 ☆	6904 5311	KB guide D	M31631A-1	1			X
15 ☆	0002 8827	KB chassis	M2992-1	1			X
17) WHEEL ASS'Y							
16	2770 6843	Variable resistor	VM10W520A-50KB	2			B
17 ☆	3500 8151	6P connector M153B	IL-6P-95-M153	1			X
18 ☆	6904 0420	Bender spring	M41737-1	1	50		B
19 ☆	6904 0430	Felting seal 71A	M41812-1	2	10		X
20 ☆	6904 6110	Bender knob 153	M31620-1	2	10		C
21 ☆	6904 6120	Bender chassis 153	M42128-1	2			X
22 ☆	6911 5250	Bender chassis B	M41946-1	2			X
18) RAM PACK CASE ASS'Y							
23 ☆	6904 5950	RAM pack compartment upper case subass'y	M31651*1	1			X
24 ☆	6904 6090	RAM pack compartment lower case	M31621-1	1			X
25 ☆	6904 6100	RAM pack house holder	M42129-1	1			X
26 ☆	0002 8822	RAM pack cover	M31489-1	1			C
27 ☆	6911 5320	Shaft	M41948-1	1			X
28 ☆	6911 5330	Spring	M41947-1	1	50		C
29 ☆	0002 8824	PE washer	M41951A-1	2	50		C
19) BATTERY BOX SUBASS'Y							
30 ☆	3500 8258	2P connector M153A	IL-2P-40-M153	1			X
31	6000 6091	Battery spring G67	A43656-1	1	50		C
32	6324 9297	Battery spring C-G164	A43733-1	1	50		C

Note: ☆ — New part
Q'ty — Quantity used per unit
* — Minimum order/supply quantity

Rank A: Essential
B: Stock recommended
C: Others
X: No stock recommended

Item	Code No.	Part Name	Specification	Q'ty	*	Unit Price J.F. Yen (¥) (FOB: JAPAN)	R A N K
33	6328 1560	Battery spring G49	A44683-1	1	50		C
34	6345 2238	Battery spring A-G55	A42606A-1	1	50		C
35☆	0002 8826	Battery box	M1303-3	1			C
20) SIDE BOARD SUBASS'Y							
36	6904 0260	Rhythm button	M4498-11	1			C
37☆	6904 5820	Side board subass'y (Left)	M31654*1	1			C
38☆	6904 5660	Side board subass'y (Right)	M31652*1	1			C
21) KEY TOP							
39☆	6904 8640	Key top / 	M31623-6	1			C
40☆	6904 8650	Key top / 	M31623-7	1			C
41☆	6904 8660	Key top / REST	M31623-8	1			C
42☆	6904 8670	Key top / ●	M31623-9	1			C
43☆	6904 8680	Key top / ∪	M31623-10	1			C
44☆	6904 8690	Key top / 	M31623-11	1			C
45☆	6904 8700	Key top / 	M31623-12	1			C
46☆	6904 8710	Key top / 	M31623-13	1			C
47☆	6904 8720	Key top / A	M31623-14	2			C
48☆	6904 8730	Key top / B	M31623-15	2			C
49☆	6904 8740	Key top / C	M31623-16	2			C
50☆	6904 8750	Key top / D	M31623-17	2			C
51☆	6904 8760	Key top / 1	M31623-18	1			C
52☆	6904 8770	Key top / 2	M31623-19	1			C
53☆	6904 8780	Key top / 3	M31623-20	1			C
54☆	6904 8790	Key top / 4	M31623-21	1			C
55☆☆	6904 8800	Key top / 5	M31623-22	1			C
56☆☆	6904 8810	Key top / 6	M31623-23	1			C
57☆	6904 8820	Key top / 7	M31623-24	1			C
58☆	6904 8830	Key top / 8	M31623-25	1			C
59☆	6904 8840	Key top / Wave form	M31623-26	2			C
60☆	6904 8850	Key top / ENV	M31623-27	6			C
61☆	6904 8860	Key top / Key follow	M31623-28	4			C
62☆	6904 8870	Key top / Porta-Mento	M31623-29	1			C
63☆	6904 8880	Key top / Glide	M31623-30	1			C
64☆	6904 8890	Key top / Detune	M31623-31	1			C
65☆	6904 8900	Key top / Key transpose	M31624-7	1			C

Note: ☆ — New part

Q'ty — Quantity used per unit

* — Minimum order/supply quantity

Rank A: Essential

B: Stock recommended

C: Others

X: No stock recommended

Item	Code No.	Part Name	Specification	Q'ty	*	Unit Price J.F. Yen (¥) (FOB: JAPAN)	R A N K
66☆	6904 8910	Key top / Normal	M31624-8	1			C
67☆	6904 8920	Key top / Tone mix	M31624-9	1			C
68☆	6904 8930	Key top / Key split	M31624-10	1			C
69☆	6904 8940	Key top / Solo	M31624-11	1			C
70☆	6904 8950	Key top / MIDI	M31624-12	1			C
71☆	6904 8960	Key top / ▼(Value/Save)	M31624-13	1			C
72☆	6904 8970	Key top / ▲(Value/Load)	M31624-14	1			C
73☆	6904 8980	Key top / ◀(Conson/No)	M31624-15	1			C
74☆	6904 8990	Key top / ▶(Conson/Yes)	M31624-16	1			C
75☆	6904 9000	Key top / ▼Down	M31624-17	1			C
76☆	6904 9010	Key top / ▲UP	M31624-18	1			C
77☆	6904 9020	Key top / Sustain	M31624-19	1			C
78☆	6904 9030	Key top / End	M31624-20	1			C
79☆	6904 9040	Key top / MT	M31624-21	1			C
80☆	6904 9050	Key top / Cartridge	M31624-22	1			C
81☆	6904 9060	Key top / Porta-Mento	M31624-23	1			C
82☆	6904 9070	Key top / Glide	M31624-24	1			C
83☆	6904 9080	Key top / Bend range	M31624-25	1			C
84☆	6904 9090	Key top / Modulation depth	M31624-26	1			C
85☆	6904 9100	Key top / Ring	M31624-27	1			C
86☆	6904 9110	Key top / Noise	M31624-28	1			C
87☆	6904 9120	Key top / Delete	M31624-29	1			C
88☆	6904 9130	Key top / ▼Down	M31624-30	1			C
89☆	6904 9140	Key top / ▲Up	M31624-31	1			C
90☆	6904 9150	Key top / Repeat	M31624-32	1			C
91☆	6904 9160	Key top / ● Real time	M31624-33	1			C
92☆	6904 9170	Key top / ●● Manual	M31624-34	1			C
93☆	6904 9180	Key top / Reset	M31624-35	1			C
94☆	6904 9190	Key top / ◀◀ Rev	M31624-36	1			C
95☆	6904 9200	Key top / ▶▶ FWD	M31624-37	1			C
96☆	6904 9210	Key top / ▶ Play	M31624-38	1			C
97☆	6904 9220	Key top / ■ Stop	M31624-39	1			C
98☆	6904 9230	Key top / Compare/Recall	M31624-40	1			C
99☆	6904 9240	Key top / Track check	M31624-41	1			C
100☆	6904 9250	Key top / Write	M31624-42	1			C
101☆	6904 9260	Key top / ○ Record	M31624-43	1			C
102☆	6904 9270	Key top / Master tune	M31624-44	1			C
103☆	6904 9280	Key top / Sequencer	M31624-45	1			C

Note: ☆ - New part

Q'ty - Quantity used per unit

* - Minimum order/supply quantity

Rank A: Essential

B: Stock recommended

C: Others

X: No stock recommended

Item	Code No.	Part Name	Specification	Q'ty	*	Unit Price J.F. Yen (¥) (FOB: JAPAN)	R A N K
104☆	6904 9290	Key top / Line select	M31624-46	1			C
105☆	6904 9300	Key top / Vibrato	M31624-47	1			C
106☆	6904 9310	Key top / Octave	M31624-48	1			C
107☆	6904 9320	Key top / Initialize	M31624-49	1			C
22) UPPER/LOWER CASE							
108☆	6904 5730	Upper case subass'y	M31670*1	1			C
109☆	6904 5740	Upper panel subass'y (with key top set)	M1692*1	1			C
110☆	6902 6250	Blind plate (for slide volume)	M41215-1	2	(10)		C
111☆	6904 6140	DIN jack holder 153	M31619-1	1			C
112☆	6904 6420	UL cover	M42302-1	1			C
113☆	6904 5670	Lower case subass'y	M21015*1	1			C
23) OTHERS							
114	6901 4240	Battery cover	M3615-2	1			C
115☆	6901 6470	Transformer holder	M4887-1	2			X
116	6904 0050	Power switch knob	M41093-3	1			C
☆	6904 6150	Case stopper rubber	M42190-1	1	10		C
117☆	6904 6160	VR knob 153	M31622-1	2	10		C
☆	6920 2270	Clip	CS-5	1	10		C
☆	6904 6430	Dust cover	M31736-1	1			C
	3700 9491	Plug cord set	6.3MPP-L300-H-9	1			C

Note: ☆ — New part
Q'ty — Quantity used per unit
* — Minimum order/supply quantity

Rank A: Essential
B: Stock recommended
C: Others
X: No stock recommended

EXPLODED VIEW

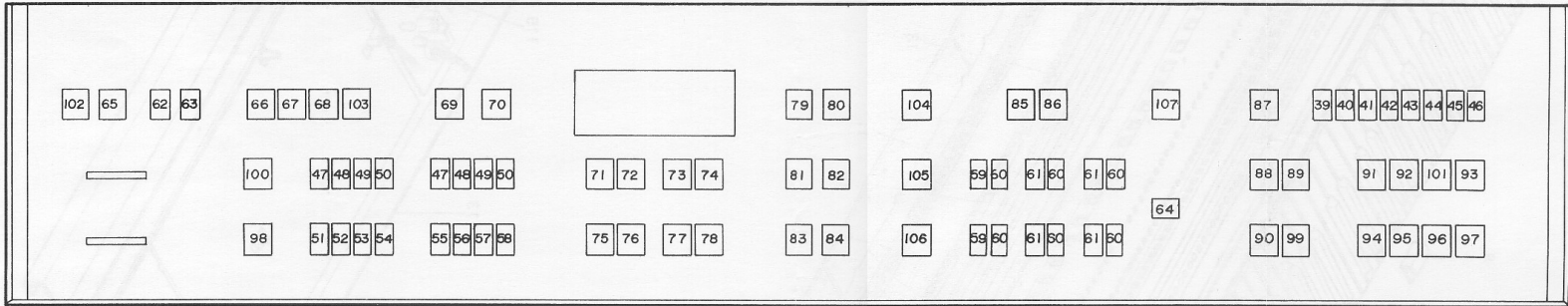

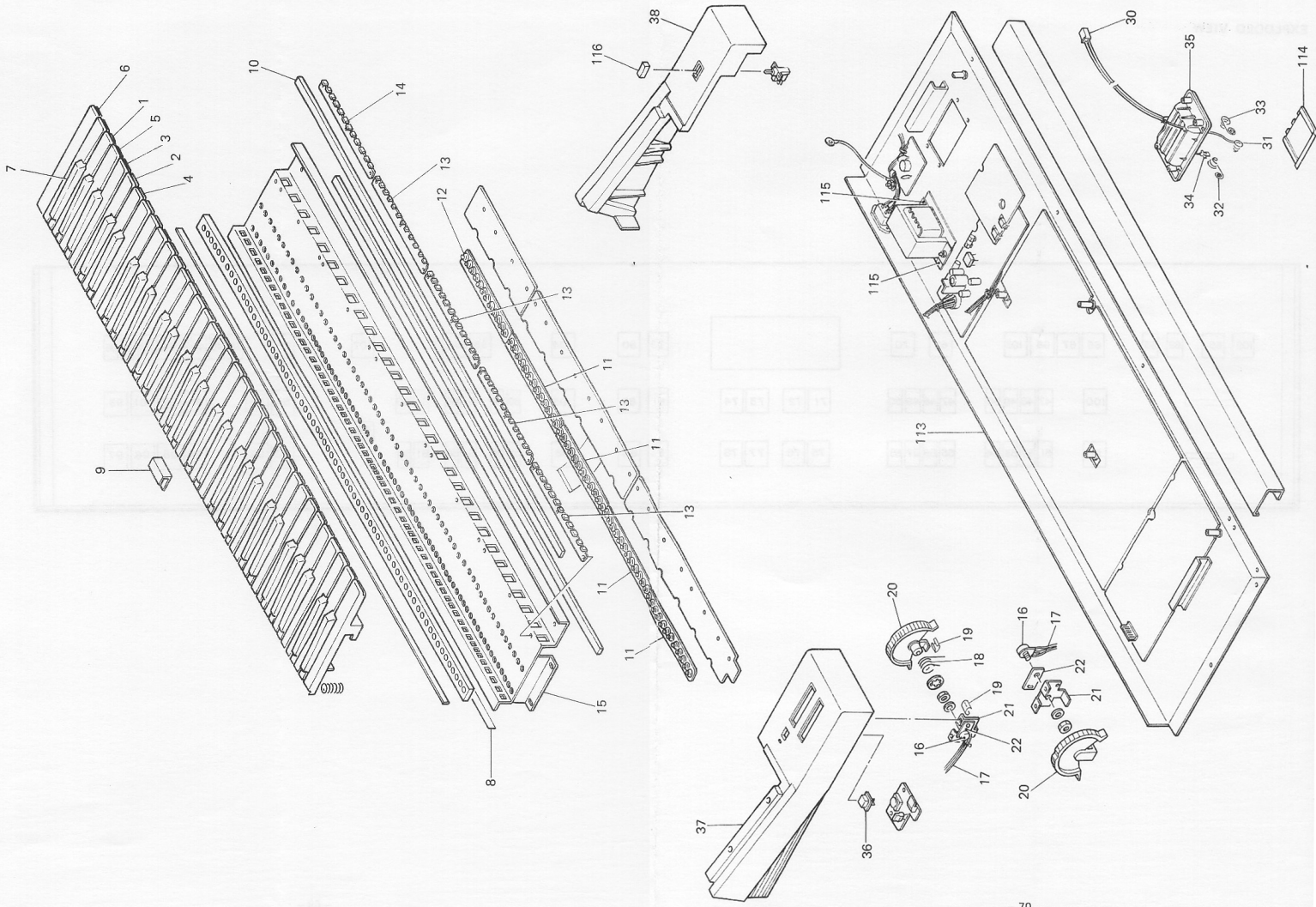

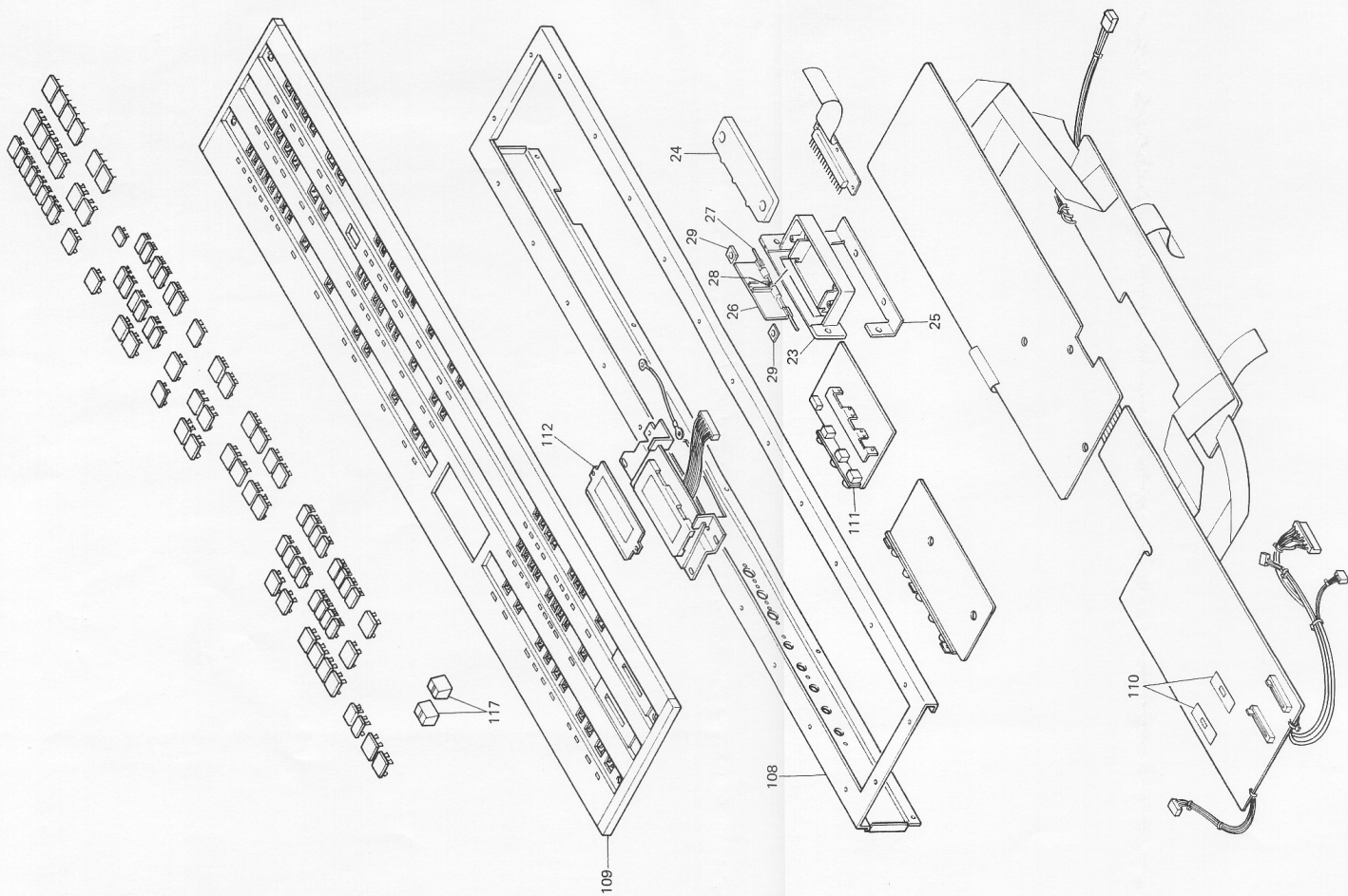

scanned by Killian