

**FARFISA**

# *Polychrome*











SCHEMATIC DIAGRAM  
&  
TECHNICAL INFORMATION

Model No 111225

SE 313  
June '82

## SCHEMATIC NOTES

	FEMALE CONNECTOR
	MALE CONNECTOR
	OUTPUT SIGNAL (to DWG .....) or (to PA .....)
	INPUT SIGNAL (from DWG .....) or (from PA .....)
	CONNECTING POINT (ON p.c.b.)
	TEST POINT (TP .....)
	CONNECTING POINT (OFF p.c.b.)
	RESISTOR MOUNTED ON RIVET (ELEVATED ON p.c.b.)

All Resistors 1/4w unless otherwise specified



All Capacitors are in microfarad unless otherwise specified

All Tabswitches, Keyswitches and Push button switches show OFF position

See part list for component part numbers

All D.C. voltages measured to ground with a voltmeter 20.000  $\Omega$  /V

### WIRE COLOURS CORRESPONDING TO SUPPLY VOLTAGE:

Grey	V > +15V		Green	SUPPLY GROUND	
Blue	+15V		Black	CHASSIS GROUND	
Red	+12V		White	-12V	
Orange	+ 5V		Yellow	-15V	

### ABBREVIATIONS OF WIRE COLOURS

WHITE	(WH)		ORANGE	(OR)		VIOLET	(VI)
RED	(RE)		GREEN	(GR)		IVORY	(IV)
BLACK	(BK)		BROWN	(BR)		SKY BLUE	(SB)
YELLOW	(YE)		GREY	(GY)		PINK	(PK)
BLUE	(BL)		BLACK-GREY	(BG)			

### PLEASE NOTE

*For a correct operation of the instrument, after having switched it off, be careful to wait at least 3 secs. before switching it on again.*

### AVVERTENZA

*Dopo aver spento lo strumento, per un corretto funzionamento, attendere almeno 3 secondi prima di riaccenderlo.*

### ATTENTION

*Pour un usage approprié de l'instrument, attendre environ 3 secondes pour le rallumer après l'avoir éteint.*

### ACHTUNG

*Damit das Instrument gut funktionieren kann, nach seiner Ausschaltung müssen wenigstens 3 Sekunden vergehen, bevor es wieder eingeschaltet wird.*

POLYCHROME INDEX

Description	Page
Mechanical spare parts (see complete list at page...)	1
How to change fuses	2
Front view of the open instrument	2
Front view of the open instrument	3
Block diagram (DWG 1)	4
PA 1105 - Keyswitches & Touch control (DWG 2)	5
PA 1105 - Component layout	5
PA 1110 - Component layout	6
PA 1110 - Generation & Scanning Logic (DWG 3)	7
PA 1214 - (1/3) Split Memory Tab	7
PA 1214 - (2/3) Pitch pot. (P 1)	7
Po2 - Pitch Bend pot.	7
PA 1135 & PA 1135/1 - Component layout	8
PA 1136 & PA 1137 - Component layout	8
PA 1135/1 - Percussion Generation (DWG 4)	9
PA 1135 - Soft Generation	9
PA 1136 - Soft envelope module	9
PA 1137 - Percussion envelope module	9
PA 1106 - Component layout	10
PA 1106 - Percussive filters (DWG 5)	10
PA 1192 - (1/5) Percussive Decay pot.	10
PA 1192 - (2/5) Percussive Emphasis pot.	10
PA 1192 - (3/5) Percussive Brilliance pot.	10
PA 1192 - (4/5) Percussive Volume pot.	10
PA 1195 - (1/4) Phaser Tremolo pot.	10
PA 1108 - Component layout	11
PA 1108 - Soft filters (DWG 6)	11
PA 1193 - (1/5) Strings Attack pot.	11
PA 1193 - (2/5) Strings Brilliance pot.	11
PA 1193 - (3/5) Strings Volume pot.	11
PA 1193 - (4/5) Strings Release pot.	11
PA 1194 - (1/5) Ensemble Attack and Brilliance pot.	11
PA 1194 - (2/5) Ensemble Sustain pot.	11
PA 1194 - (3/5) Ensemble Volume pot.	11
PA 1194 - (4/5) Ensemble Emphasis pot.	11
PA 1192 - PA 1193 - PA 1194 - Component layout	12
PA 1195 & PA 1196 - Component layout	12
PA 1192 - (5/5) Percussive controls & Tabs (DWG 7)	13
PA 1193 - (5/5) Strings controls & Tabs	13
PA 1194 - (5/5) Ensemble controls & Tabs	13
PA 1195 - (4/4) Phaser controls & Modulation tabs	13
PA 1196 - General controls & Tabs	13

POLYCHROME INDEX

Description	Page
PA 1043/3 - Component layout	14
PA 1043/3 - Slow Delay Lines (DWG 8)	15
PA 1043/1 - Component layout	16
PA 1043/1 - Fast Delay Lines (DWG 9)	17
PA 1109 - Component layout	18
PA 1253 - Component layout	18
PA 1109 - Phaser - Prempfier - Headphone ampl. & Volume control (DWG 10)	19
PA 1253 - Swell pedal	19
PA 1195 - (2/4) Speed pot.	19
PA 1195 - (3/4) Emplhasis & Volume pot.	19
Po1 - Sensibility pot.	19
PA 1111 & Swell pedal socket	19
PA 1177/1 - Component layout	20
PA 1190 - Component layout	20
PA 1197 - Component layout	20
PA 1177/1 - Chorus conversion & Scanning (DWG 11)	21
PA 1190 - Chorus envelope module	21
PA 1197 - (1/4) Chorus Attack pot.	21
PA 1197 - (2/4) Chorus controls & Tabs	21
PA 1178/1 - Component layout	22
PA 1178/1 - Chorus generation & Filters (DWG 12)	23
PA 1197 - (3/4) Chorus Volume pot.	23
PA 1197 - (4/4) Chorus Sustain pot.	23
PA 1214 - (3/3) Chorus Tuning pot.	23
PA 1104 - Component layout	24
PA 1104 - Stabilizer	24
TARATURE ADJUSTMENT	25 ÷ 27
ELECTRONIC COMPONENT & SUNDRIES LIST	28 ÷ 33
MECHANICAL SPARE PARTS	34
NOTES	35

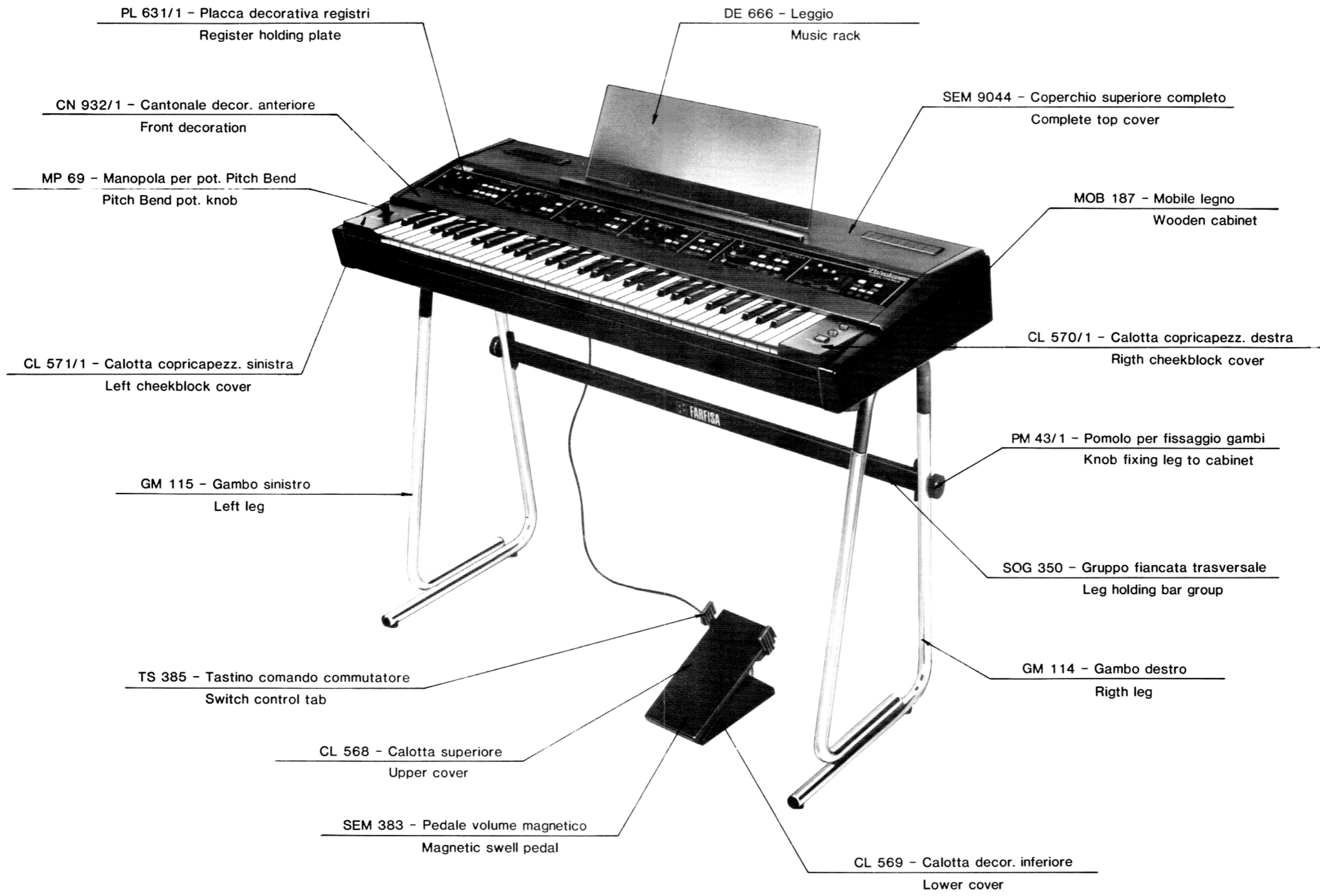

# *Polychrome*

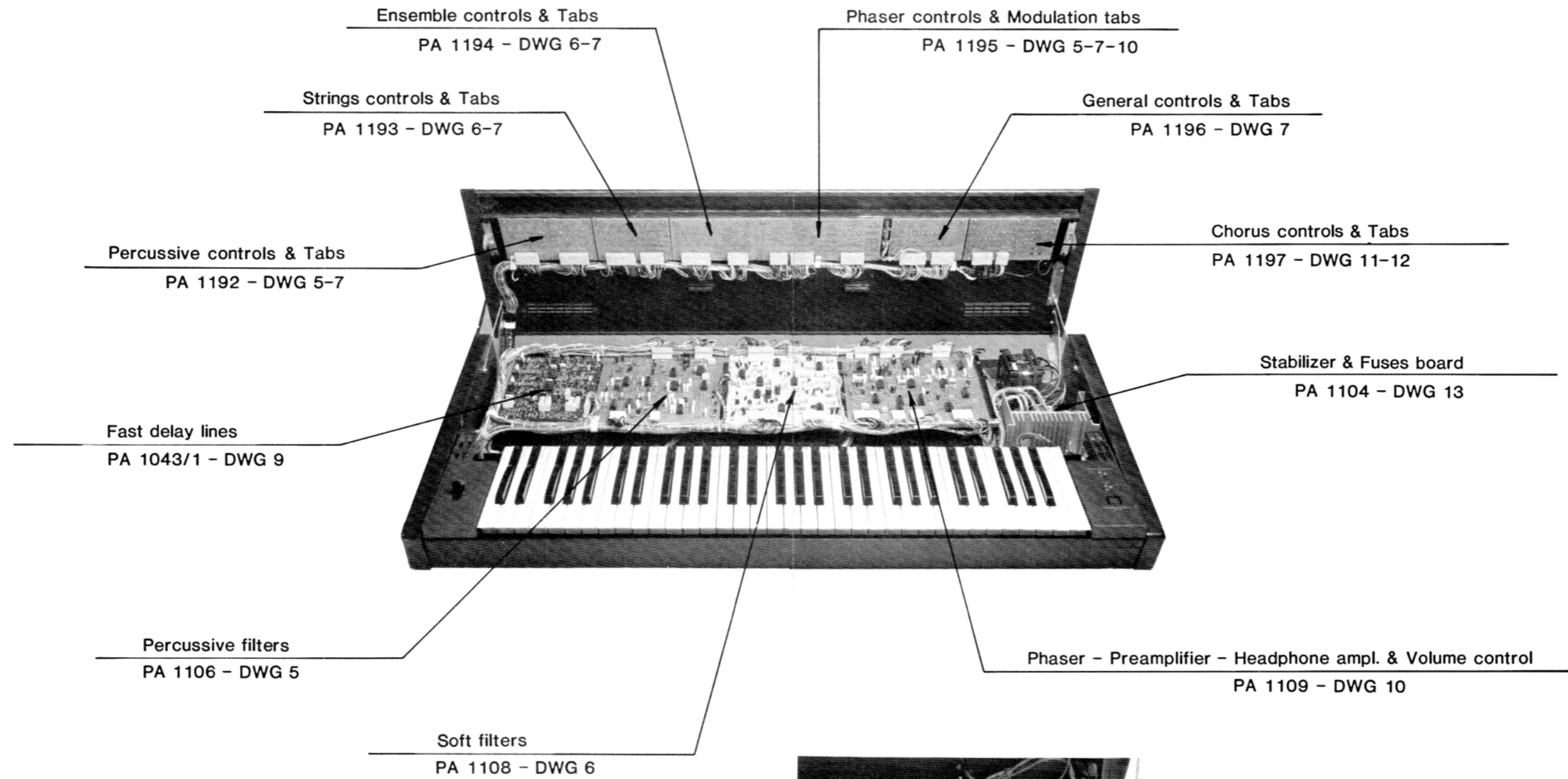

**COME CAMBIARE I FUSIBILI :**

Svitare le due viti del coperchio posteriore e ruotarlo verso il basso con attenzione, allentare le 4 viti poste sui fianchini in legno e sollevare coperchio superiore.

**HOW TO CHANGE FUSES :**

Carefully turn the back cover downward after having unscrewed the two relevant screws. Then unfasten the four screws located on the wooden side panels and lift the upper cover.

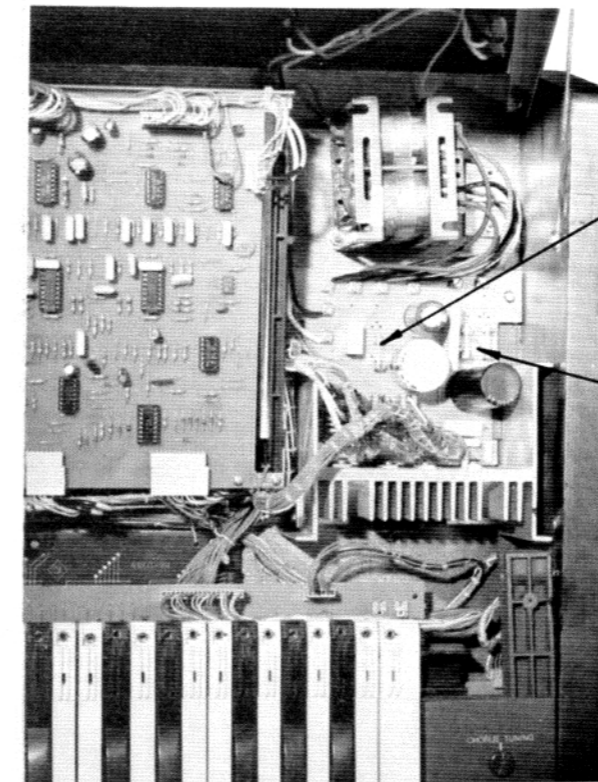

Fusibile primario  
Primary fuse

Fusibili secondario  
Secondary fuses

Soft generation  
PA 1135 - DWG 4

Chorus conversion & Scanning  
PA 1177/1 - DWG 11

Percussion generation  
PA 1135/1 - DWG 4

Stabilizer & Fuses board  
PA 1104 - DWG 13

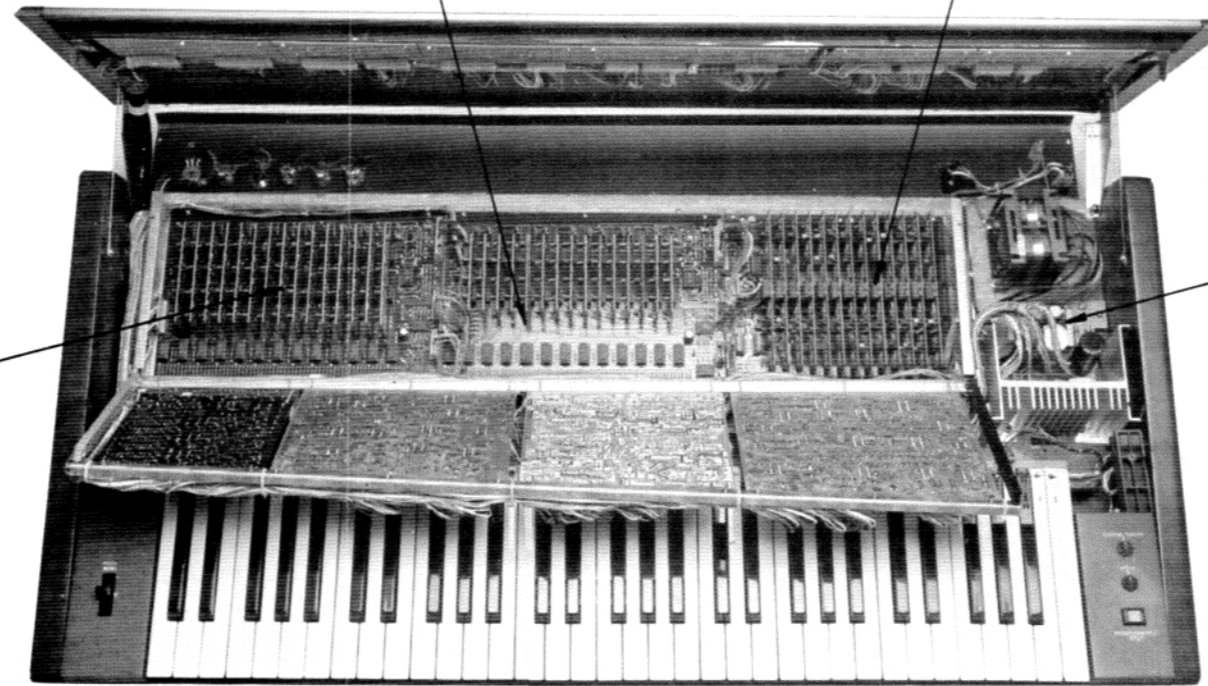

Slow delay lines  
PA 1043/3 - DWG 8

Split memory & Pitch  
PA 1214 - DWG 3-11

Keyswitches & Touch control  
PA 1105 - DWG 2

Generation & Scanning logic  
PA 1110 - DWG 3

Chorus generation & Filters  
PA 1178/1 - DWG 12

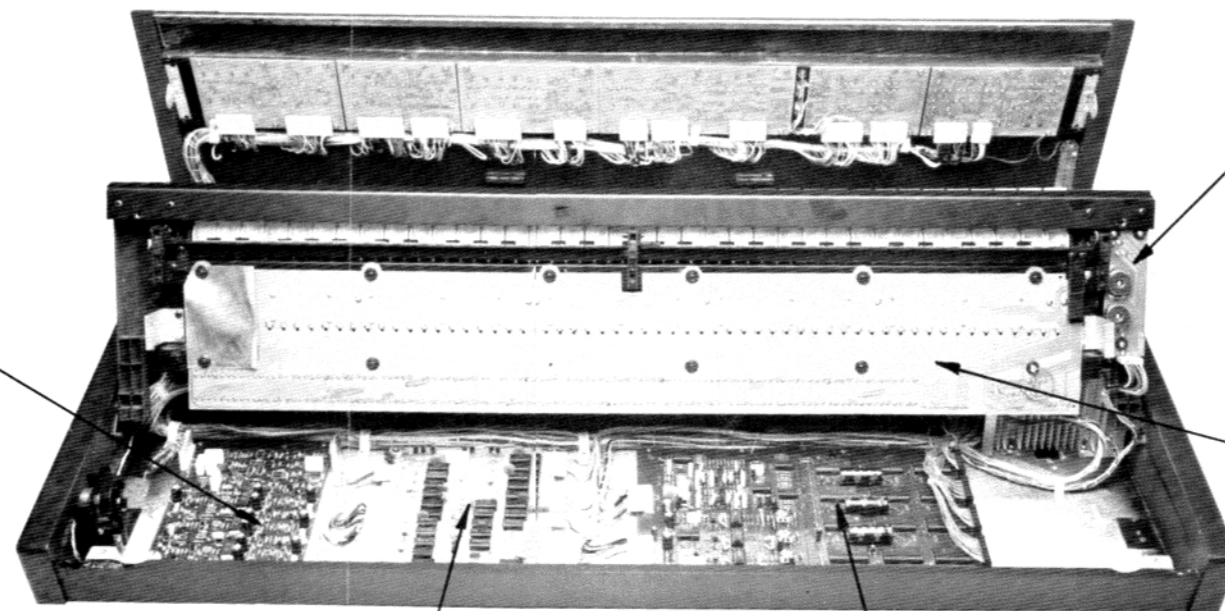

# BLOCK DIAGRAM

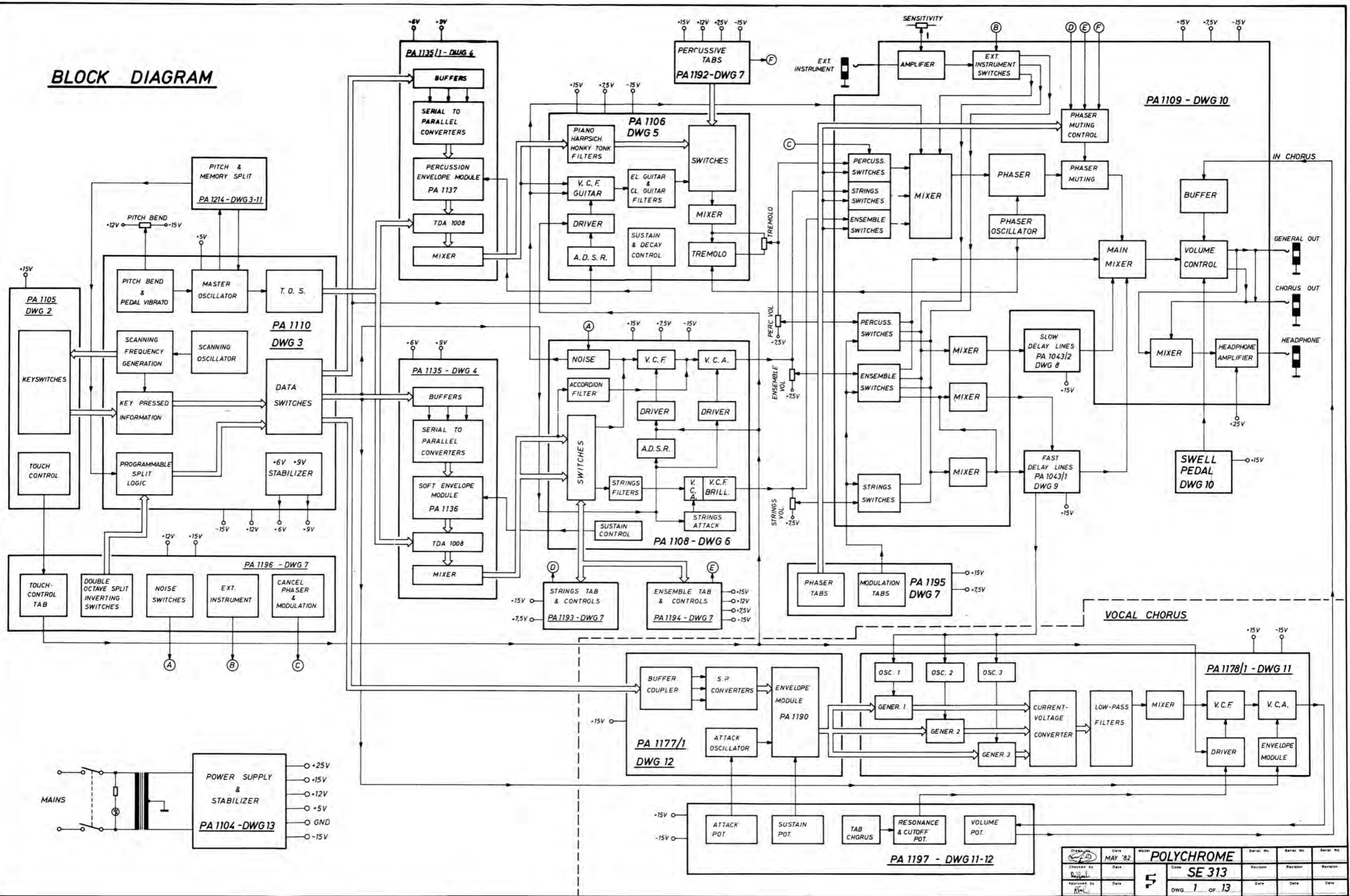

Drawn by	Date	Model	Serial No.	Serial No.	Serial No.
Checked by	MAY '82	POLYCHROME			
Approved by		SE 313			
		DWG 1 OF 13			



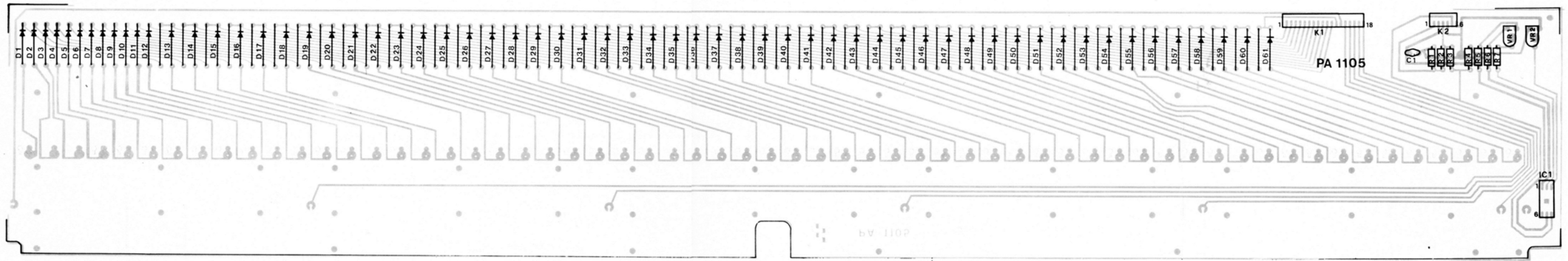

PA 1105

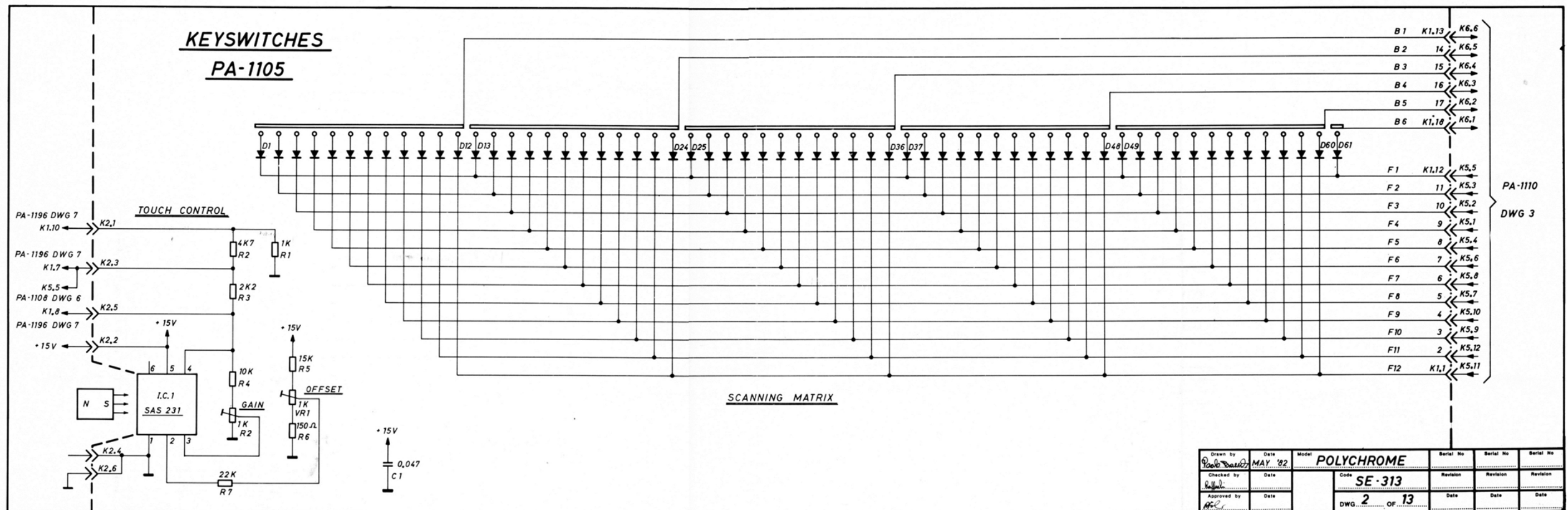

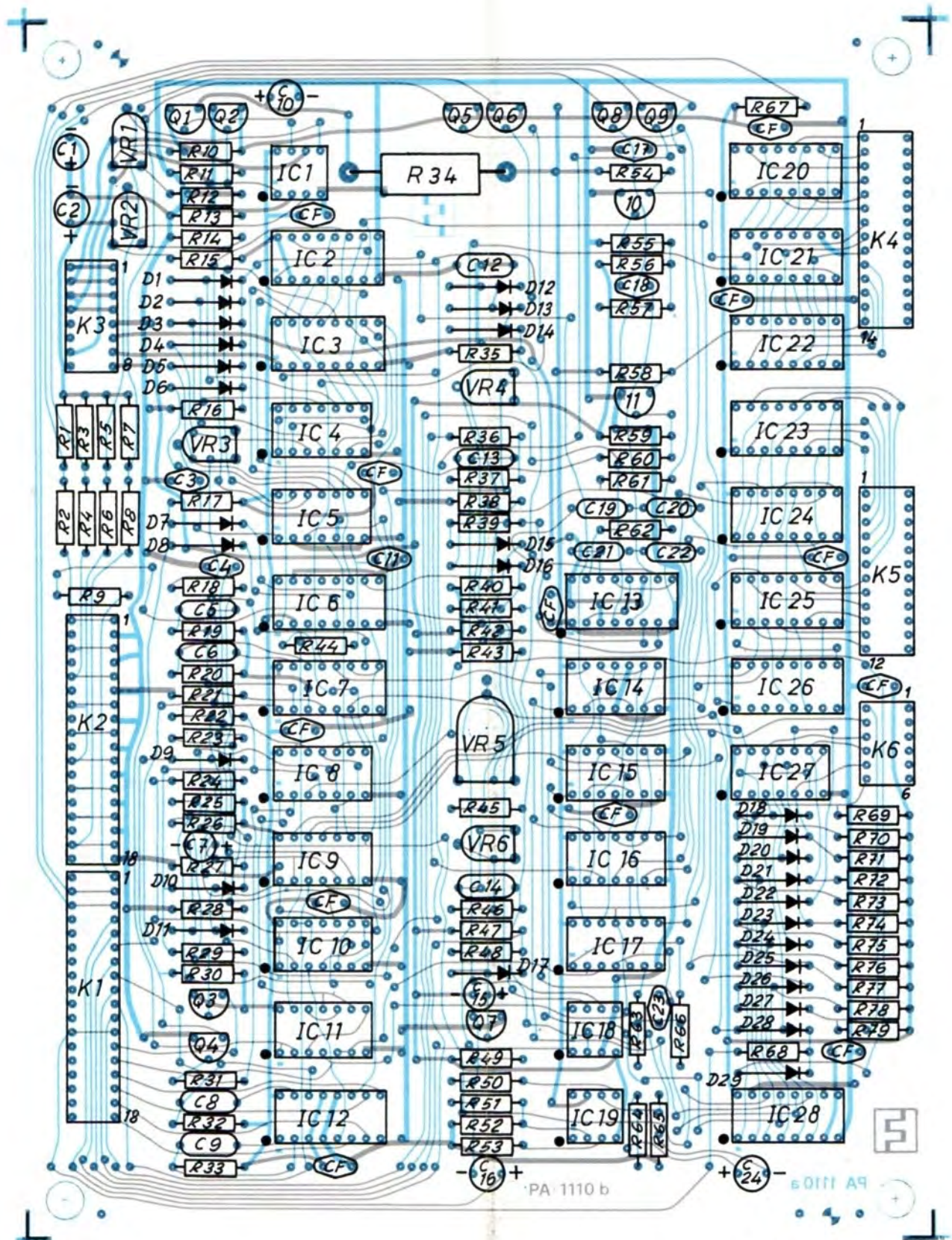

PA 1110 b

PA 1110

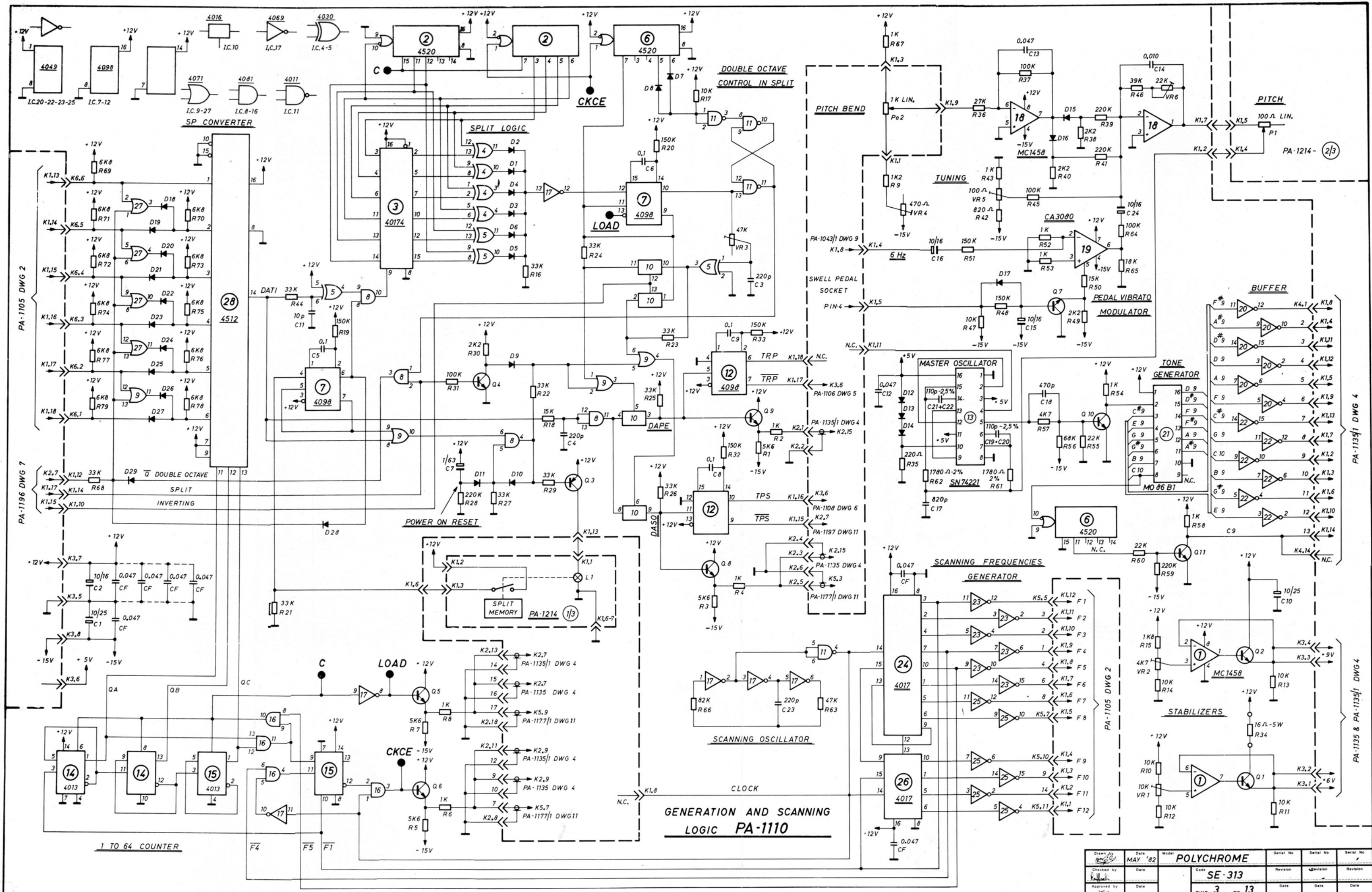

Drawn by	Date	Model	Serial No.	Serial No.	Serial No.
Checked by	Date	Code	Revision	Revision	Revision
Approved by	Date	DWG. 3 OF 13			

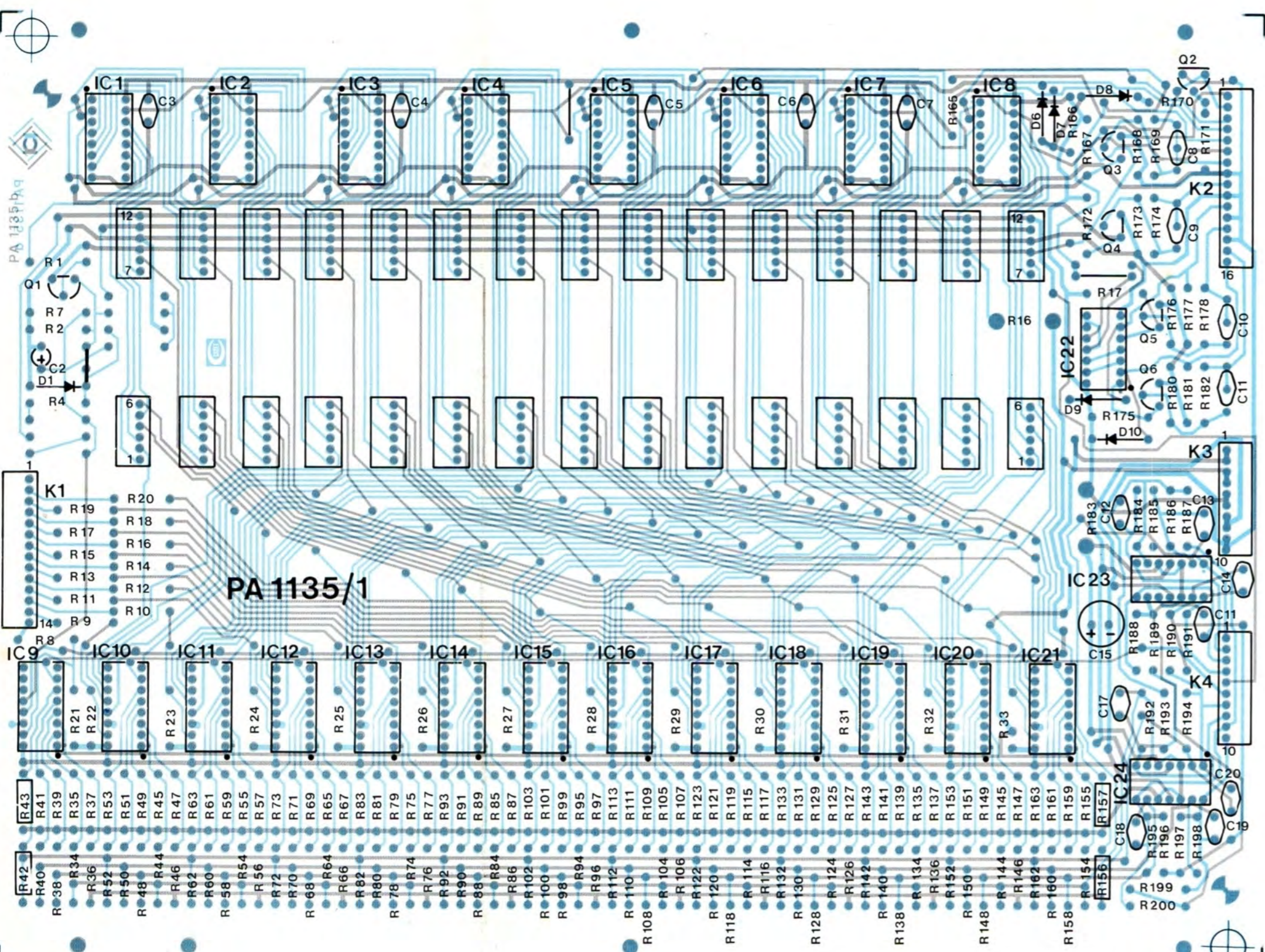

PA 1135/1

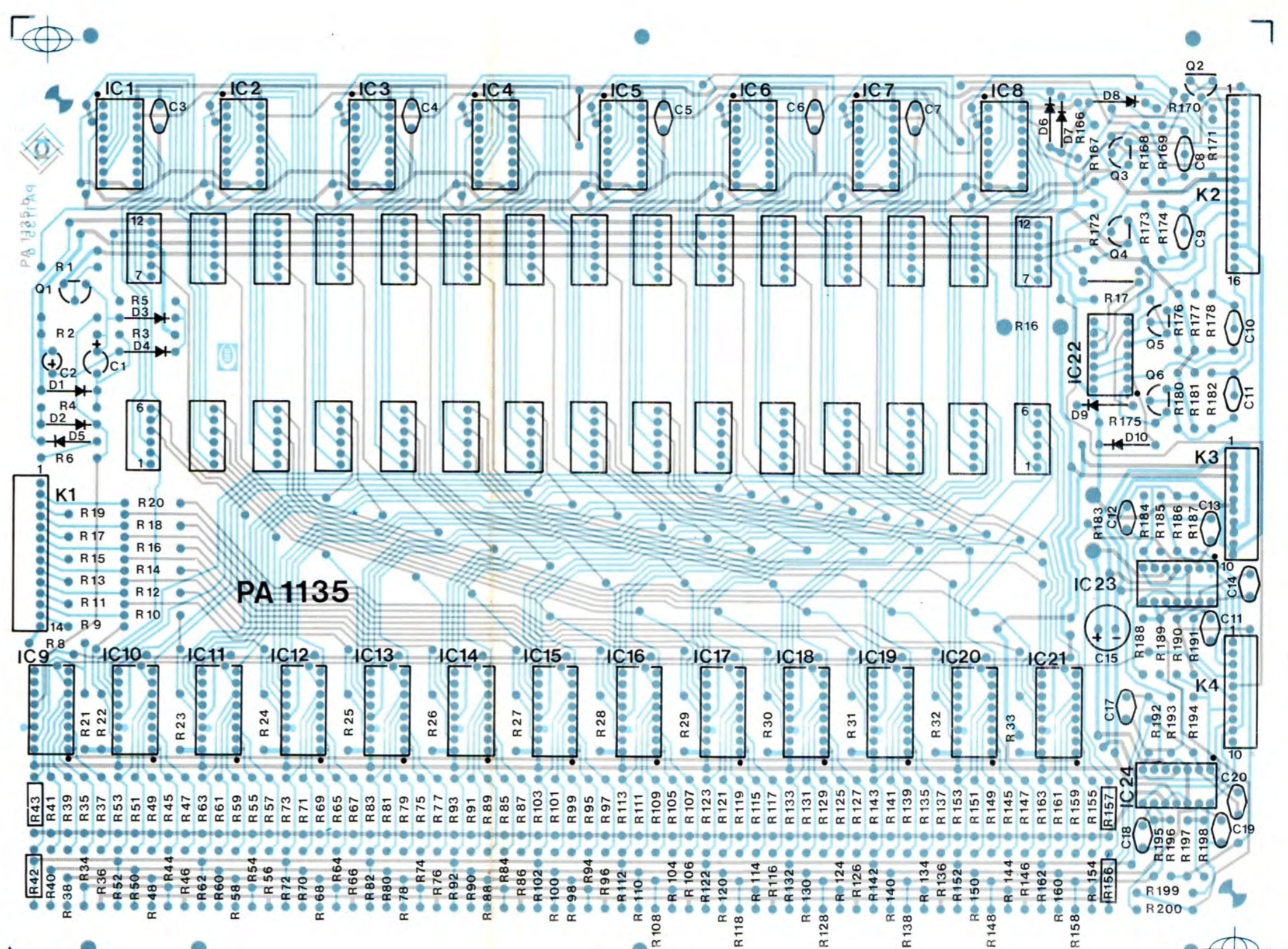

PA 1135

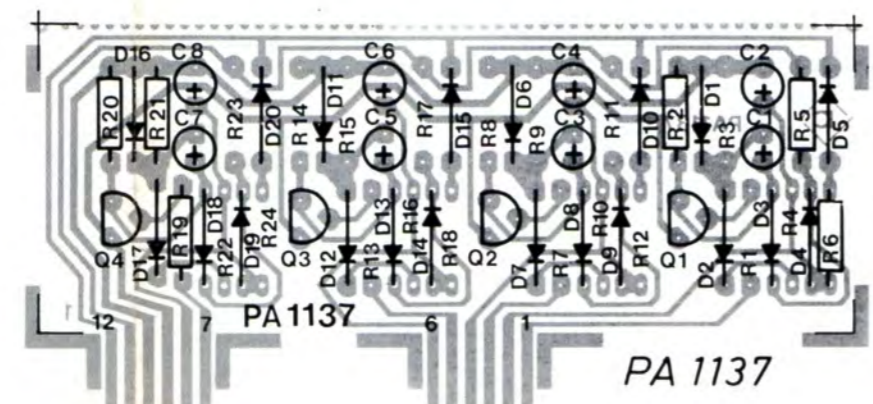

PA 1137

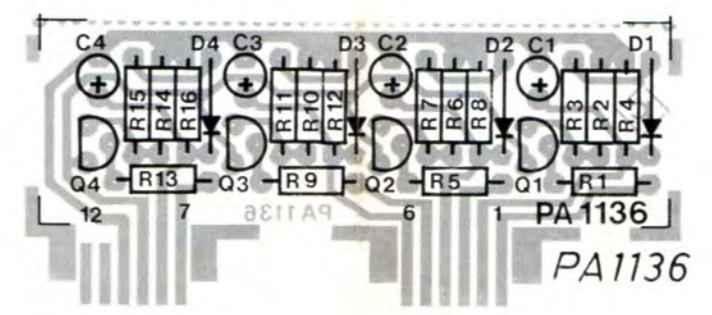

PA 1136

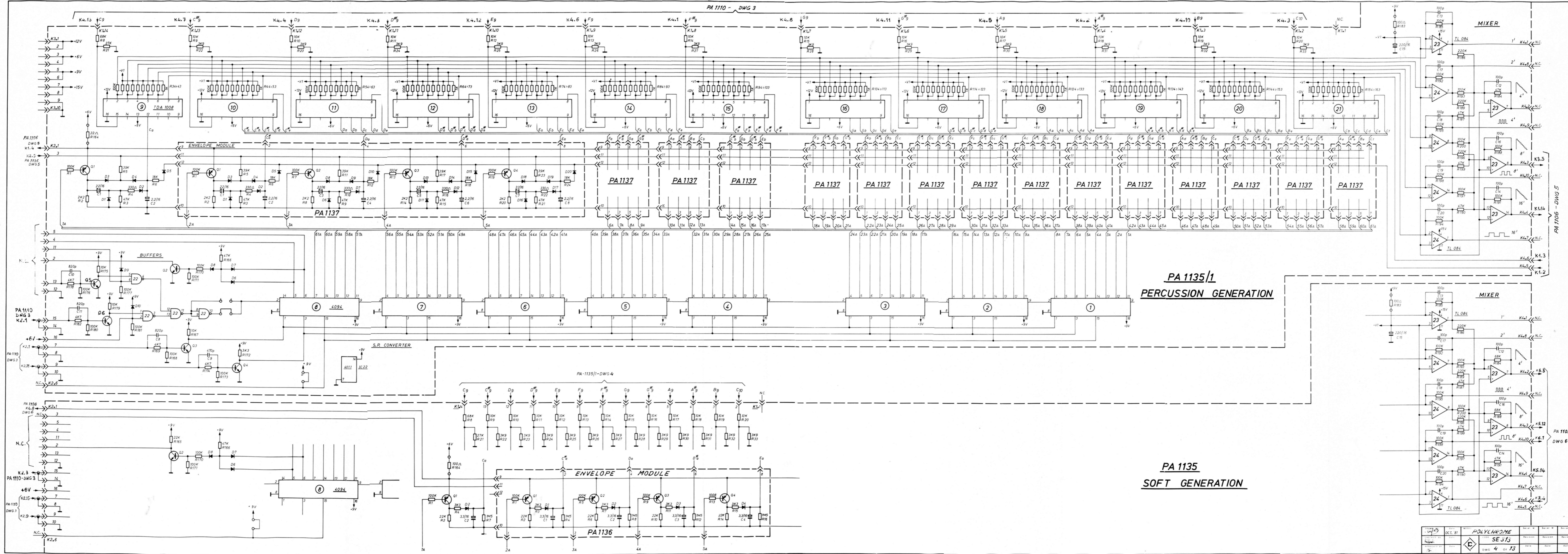

PA 1135/1  
PERCUSSION GENERATION

PA 1135  
SOFT GENERATION

REV	DATE	BY	CHKD	APP'D
1	OCT. 81			
POLYCHROME				
SE 313				
DWG 4 OF 13				

PA-1106

bV-J10E

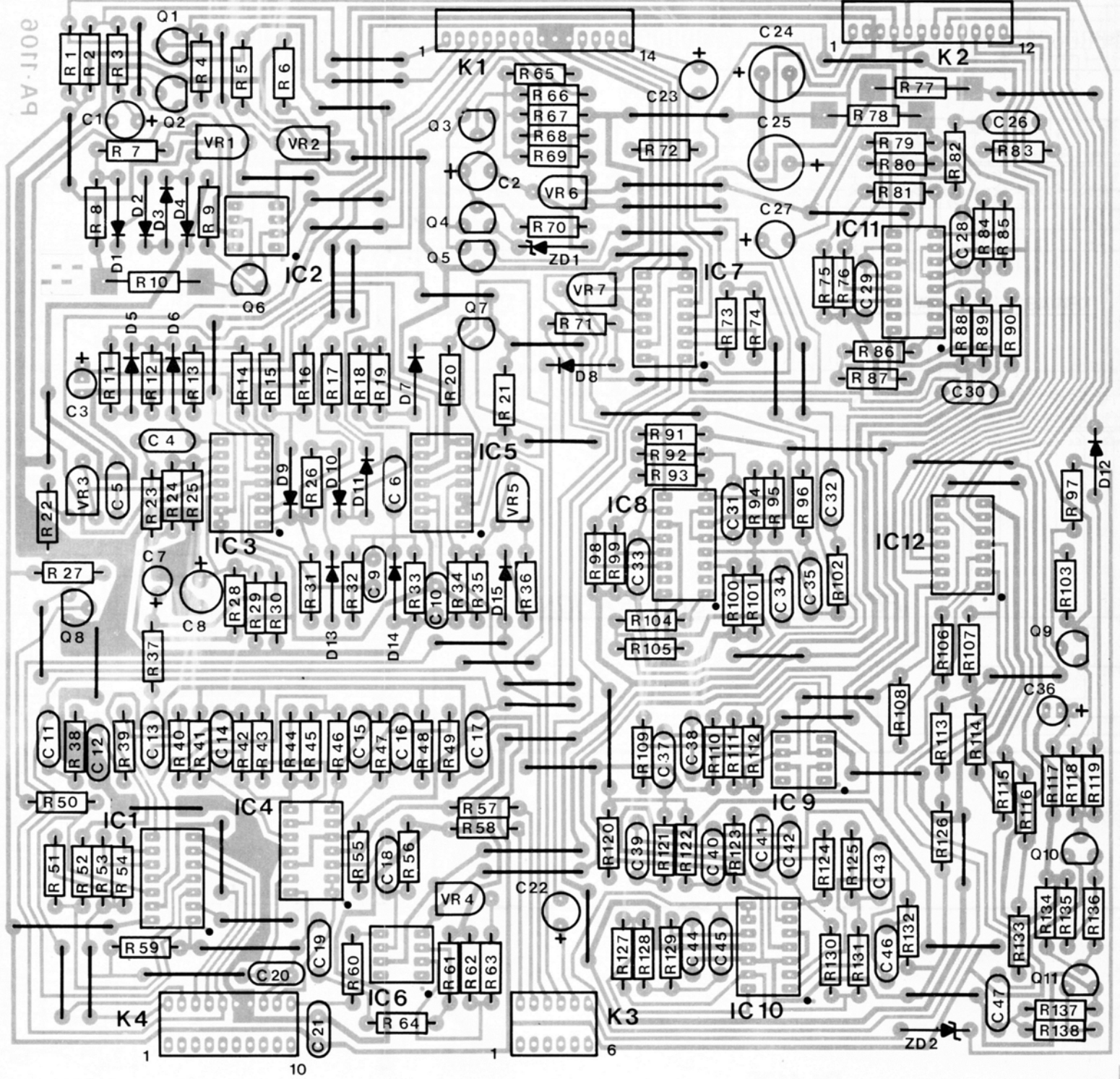

PA-1106

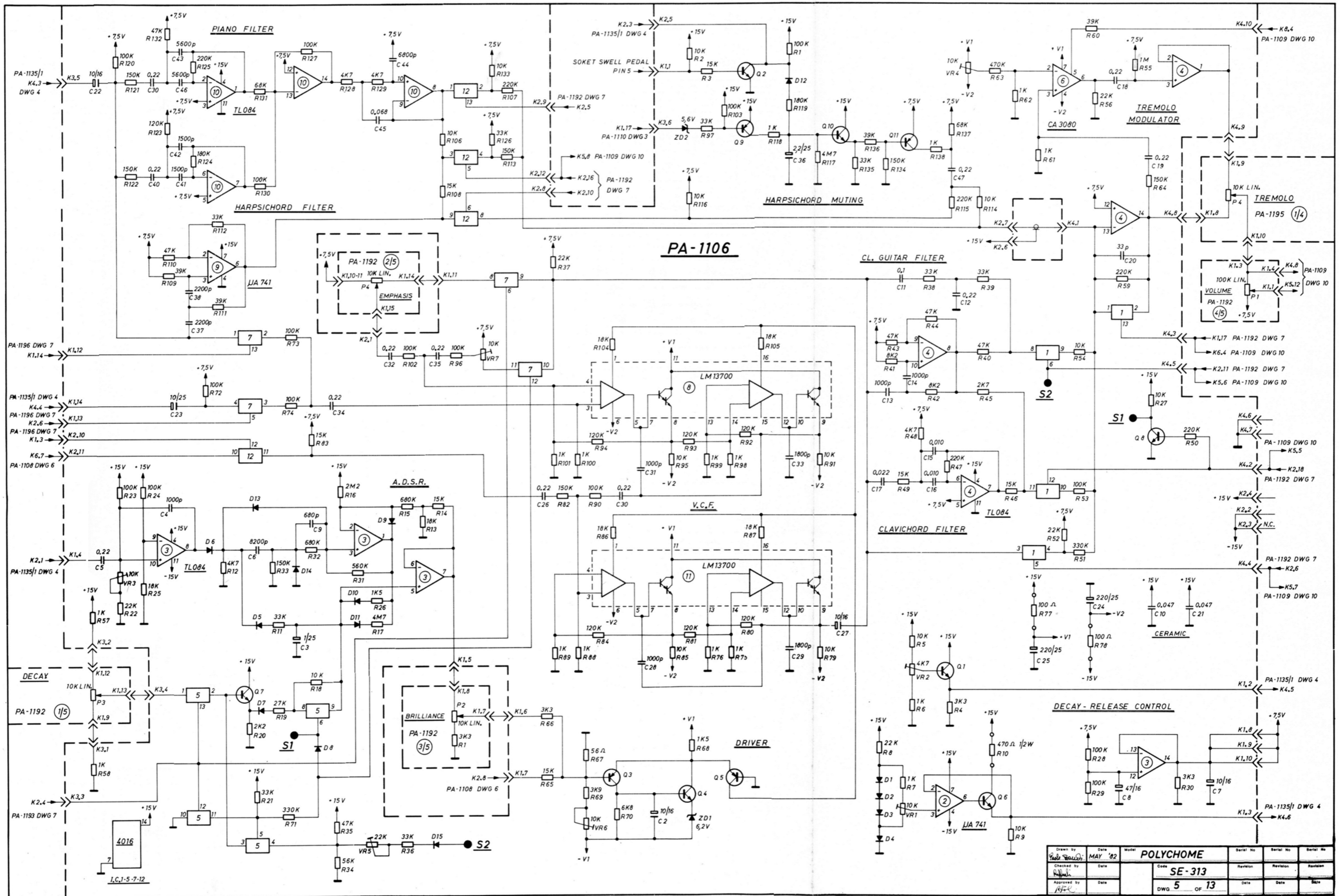

Drawn by <i>Paul S. ...</i>	Date MAY '82	Model <b>POLYCHROME</b>	Serial No.	Serial No.	Serial No.
Checked by <i>[Signature]</i>	Date	Code <b>SE-313</b>	Revision	Revision	Revision
Approved by <i>[Signature]</i>	Date	DWG <b>5</b>	of	<b>13</b>	Page

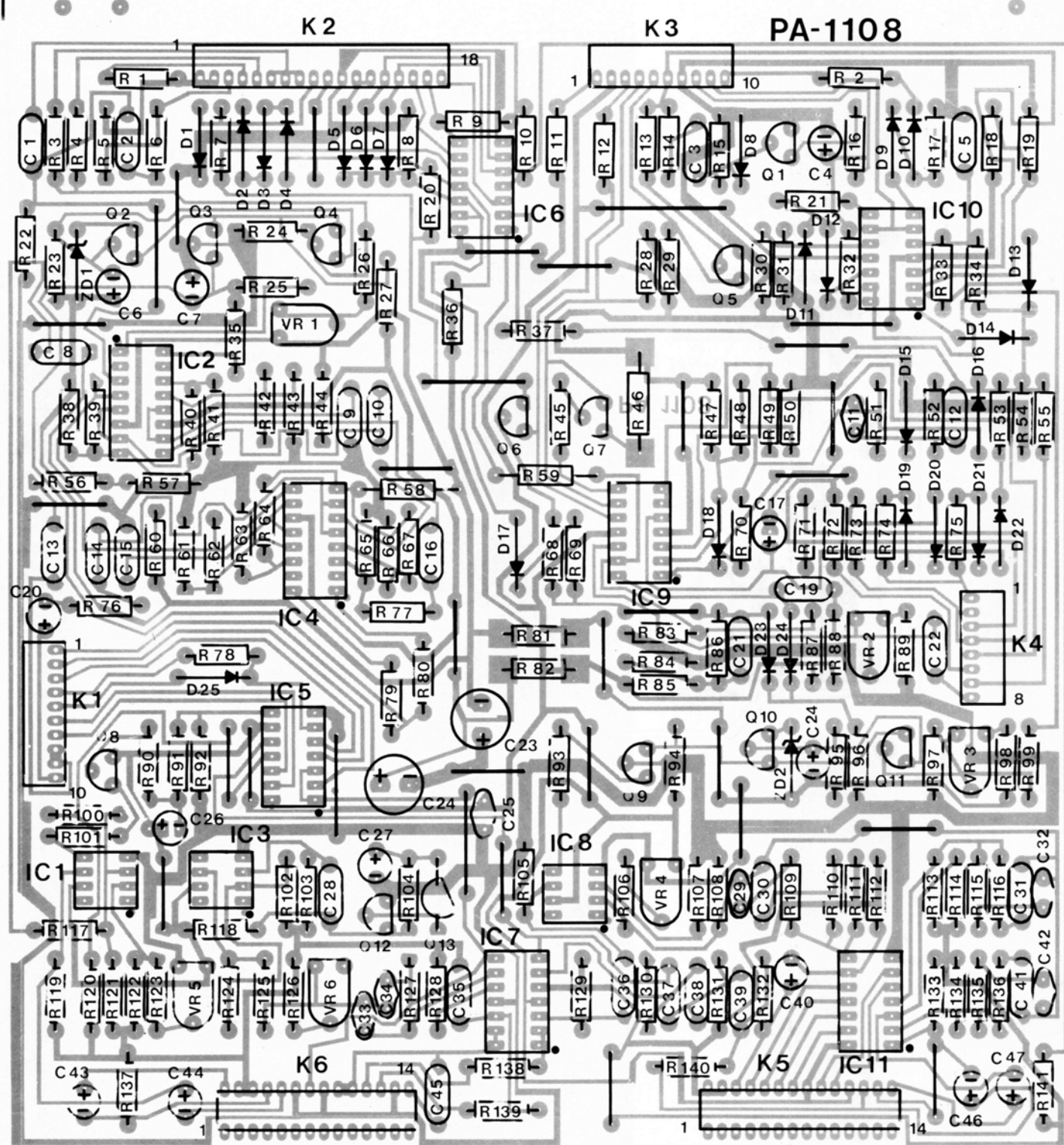

PA 1108



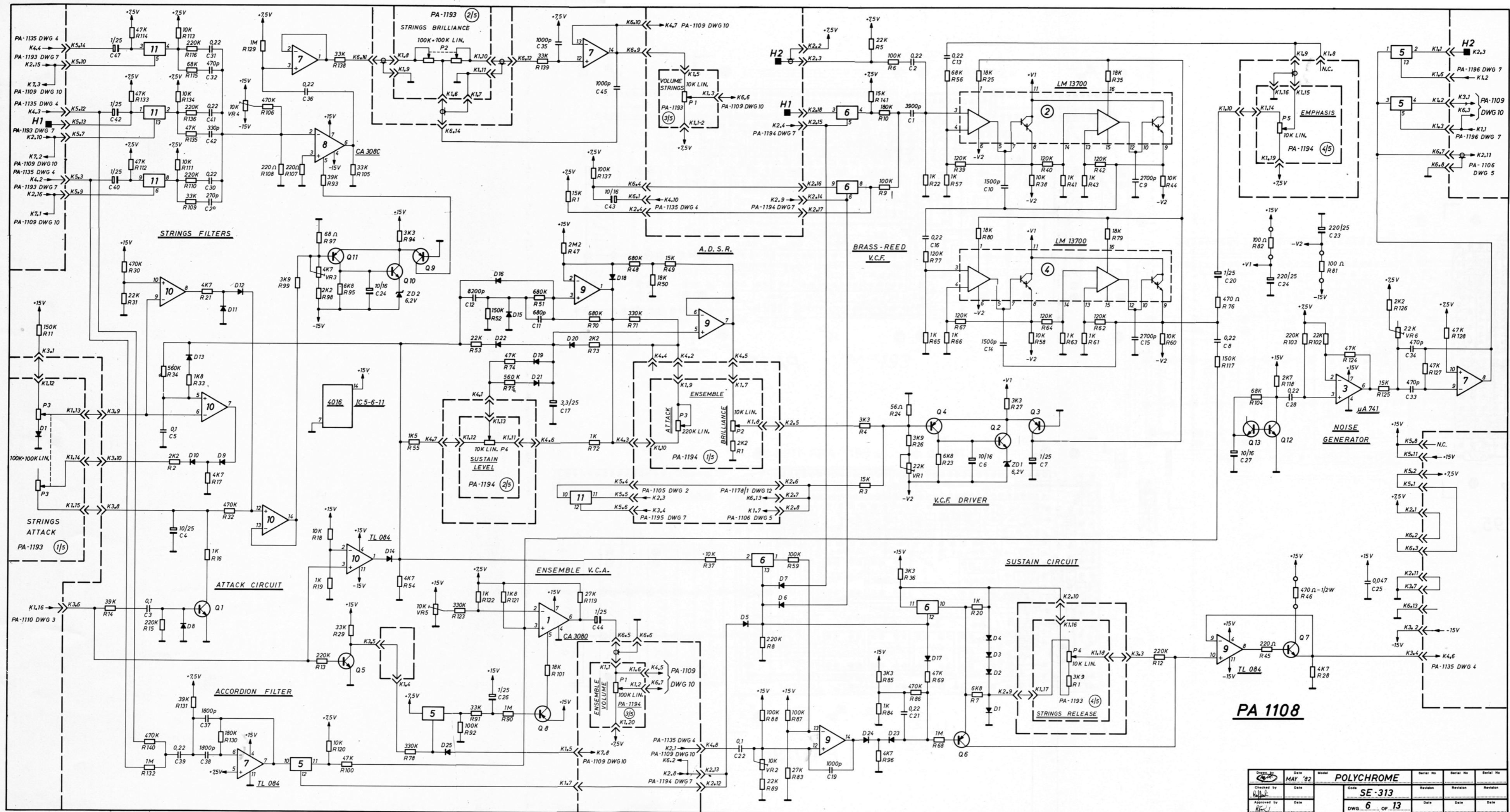

Drawn by	Date	Model	Serial No.	Serial No.	Serial No.
Checked by	Date	Code	Revision	Revision	Revision
Approved by	Date	DWG	Date	Date	Date
		POLYCHROME		SE-313	
		6		13	

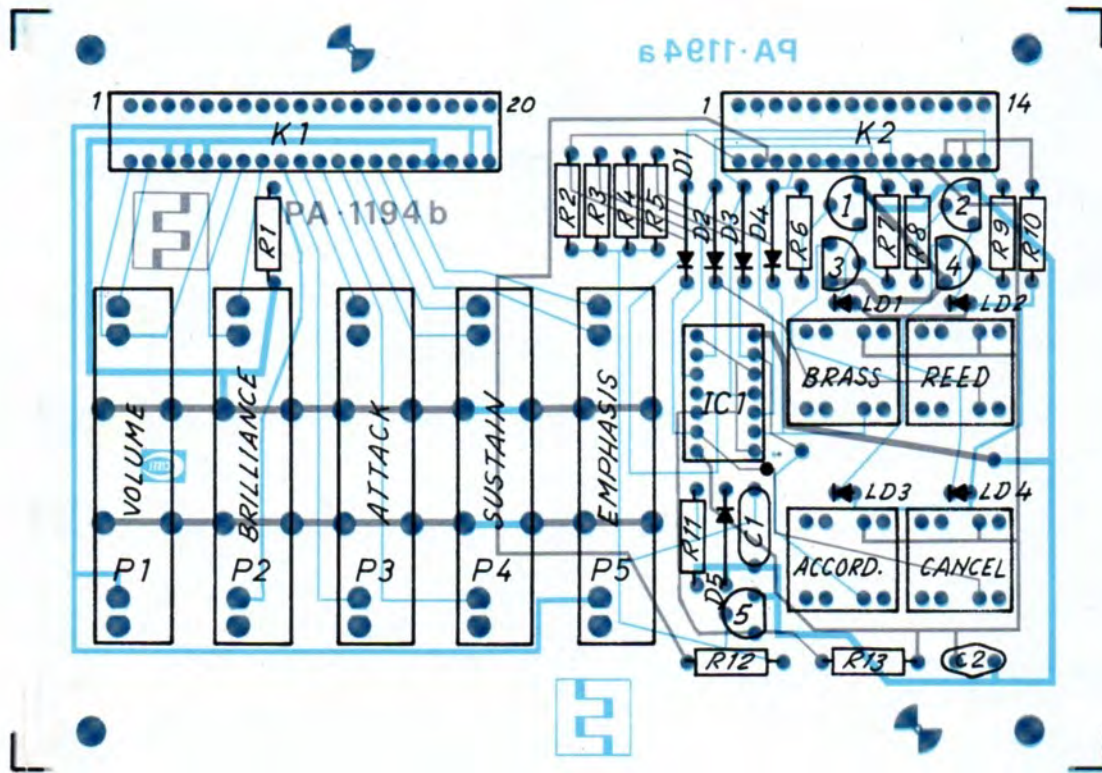
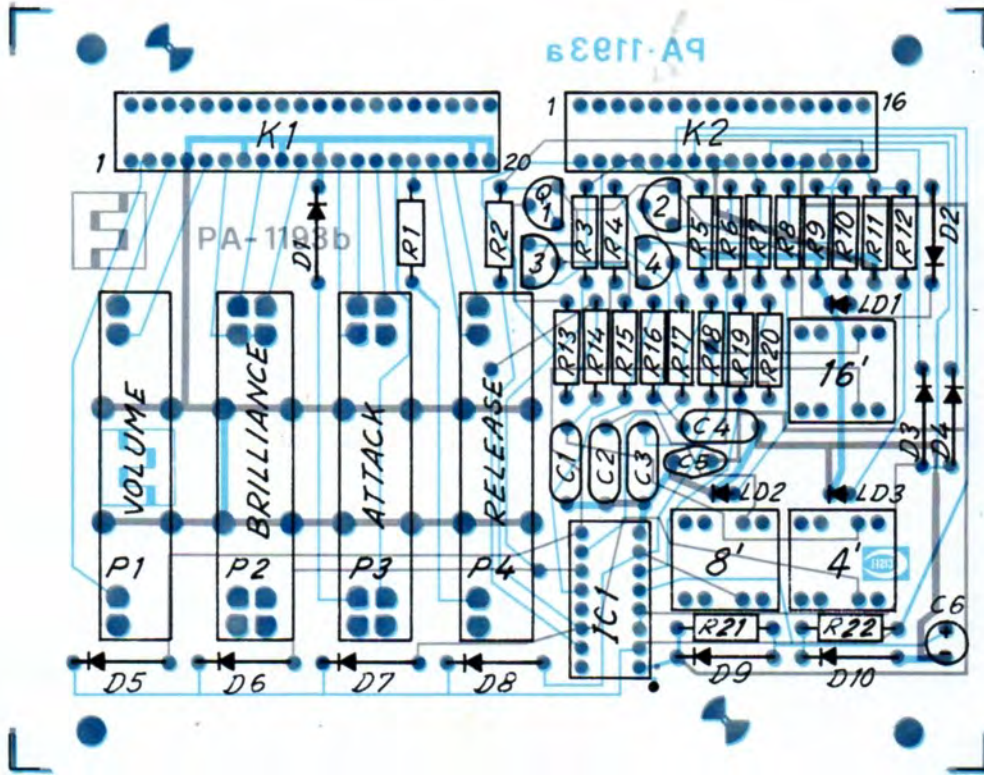

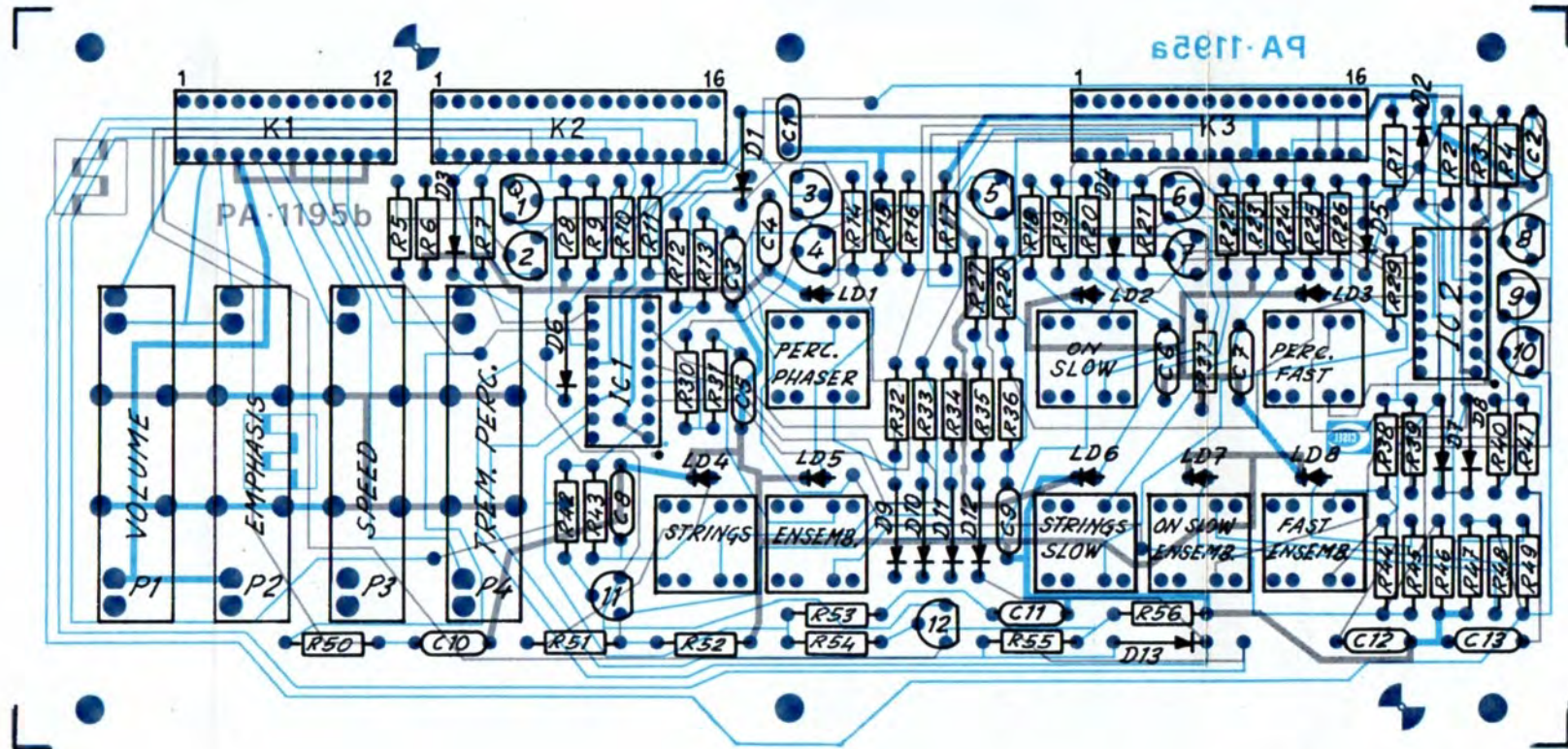

PA-1195b

PA-1195b

PA-1195



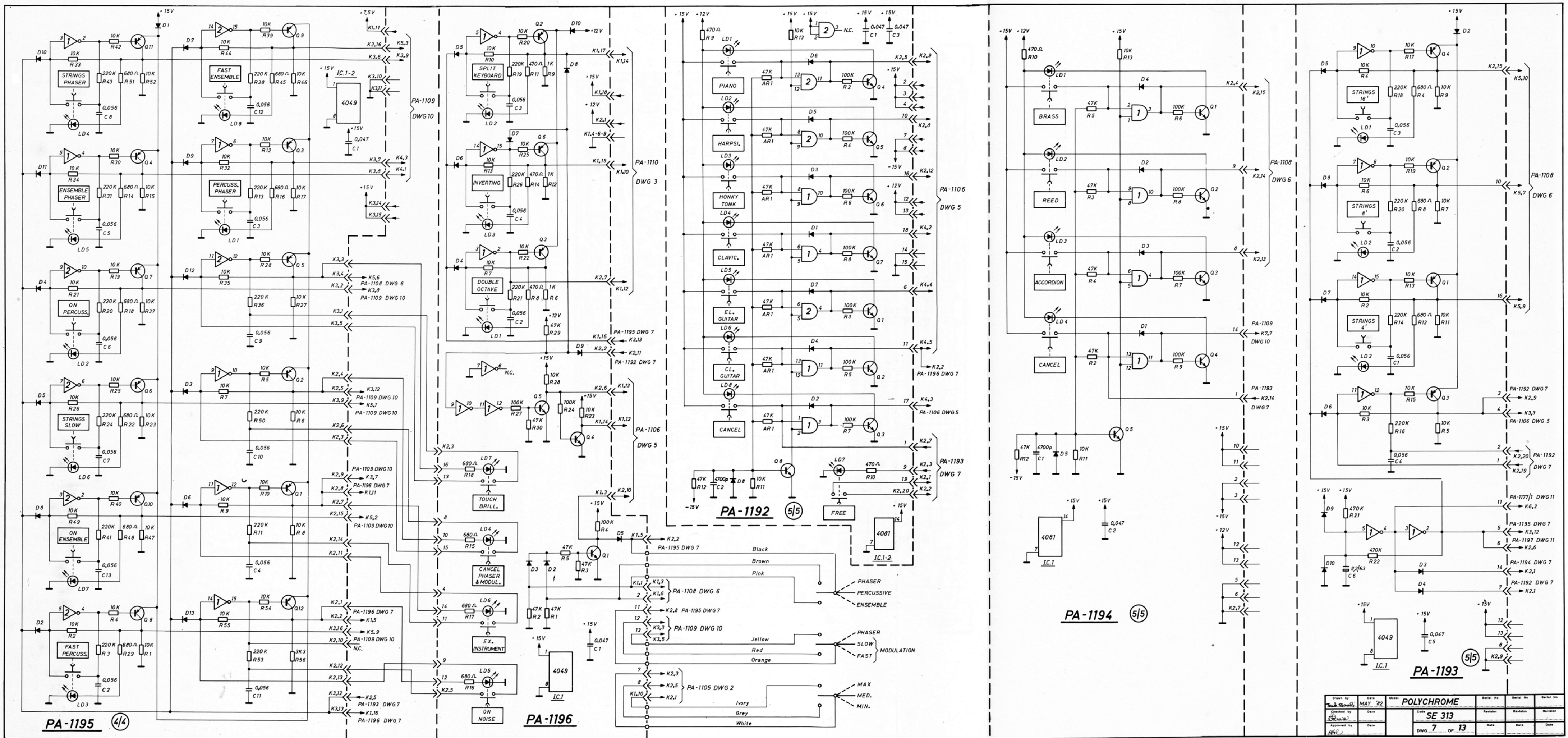

PA-1195 (4/4)

PA-1196

PA-1192 (5/5)

PA-1194 (5/5)

PA-1193 (5/5)

Drawn by	Date	Model	Serial No.	Serial No.	Serial No.
Checked by	MAY '82	POLYCHROME			
Approved by		Code	Revision	Revision	Revision
		SE 313			
		DWG. 7	OF 13		

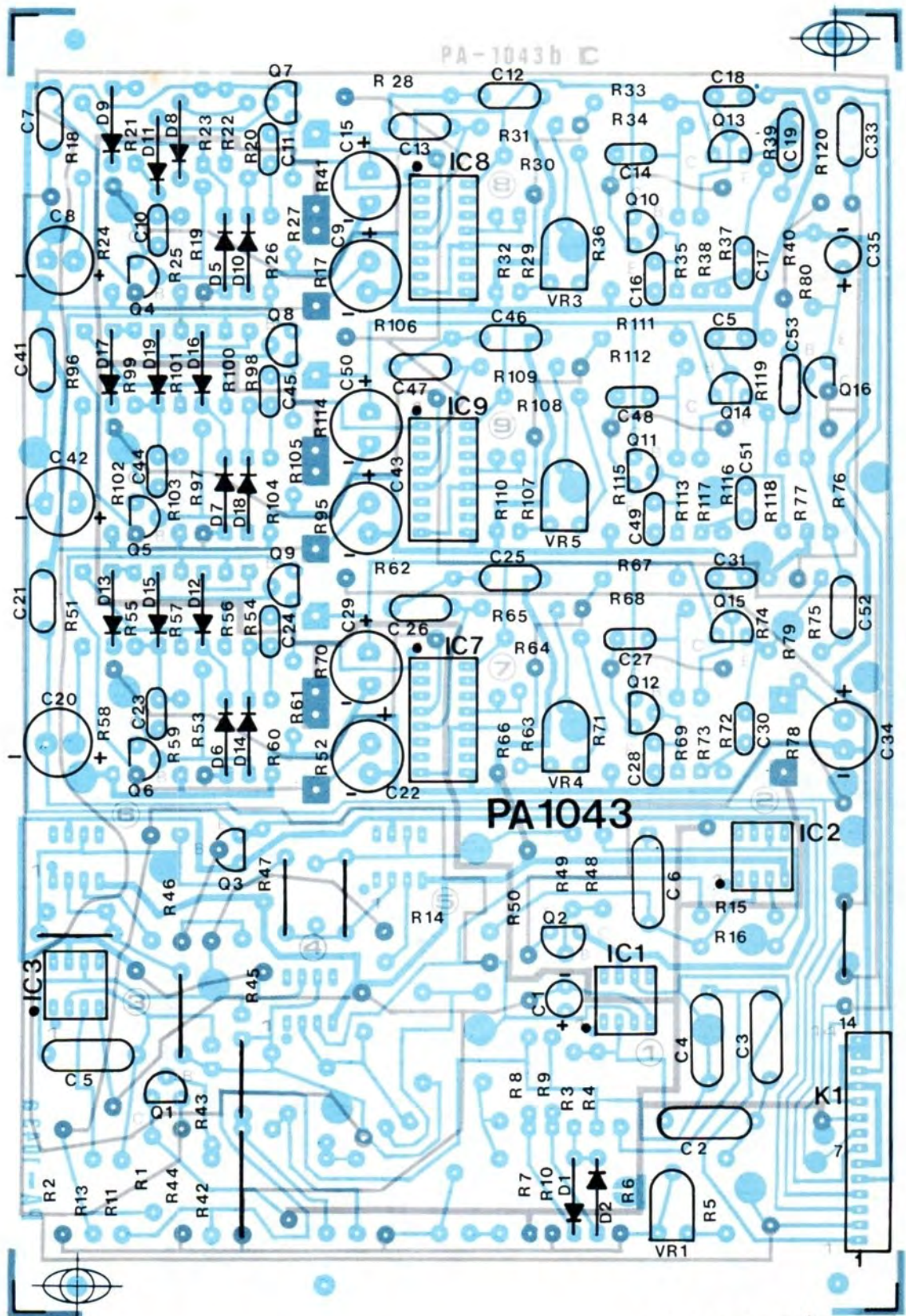

PA 1043/3

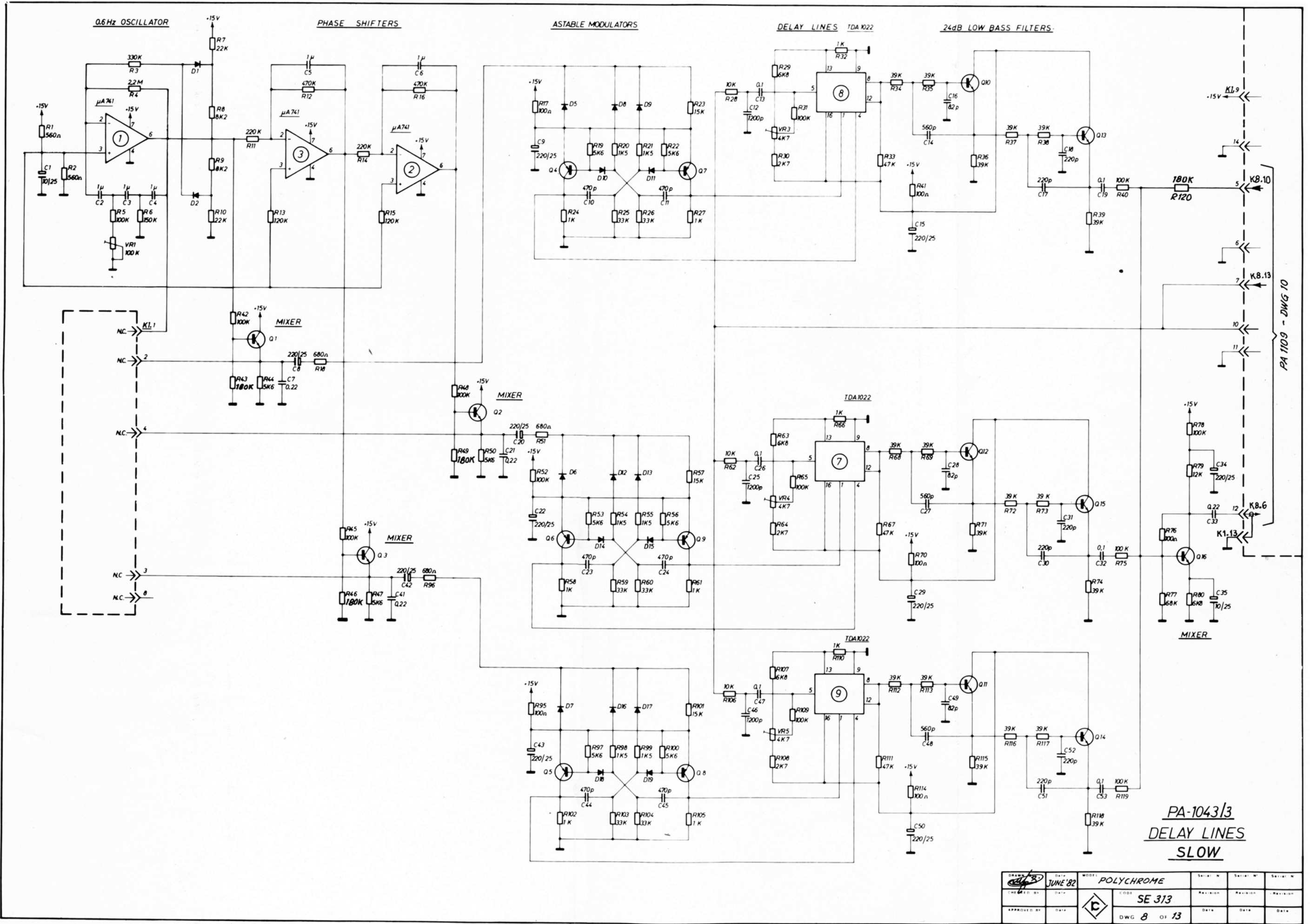

PA 1109 - DWG 10

PA-1043/3  
 DELAY LINES  
 SLOW

DATE	JUNE '82	MODEL	POLYCHROME	SHEET N	SHEET N	SHEET N
DESIGNED BY		CODE	SE 313	REVISION	REVISION	REVISION
APPROVED BY		DWG	8 OF 13	DATE	DATE	DATE

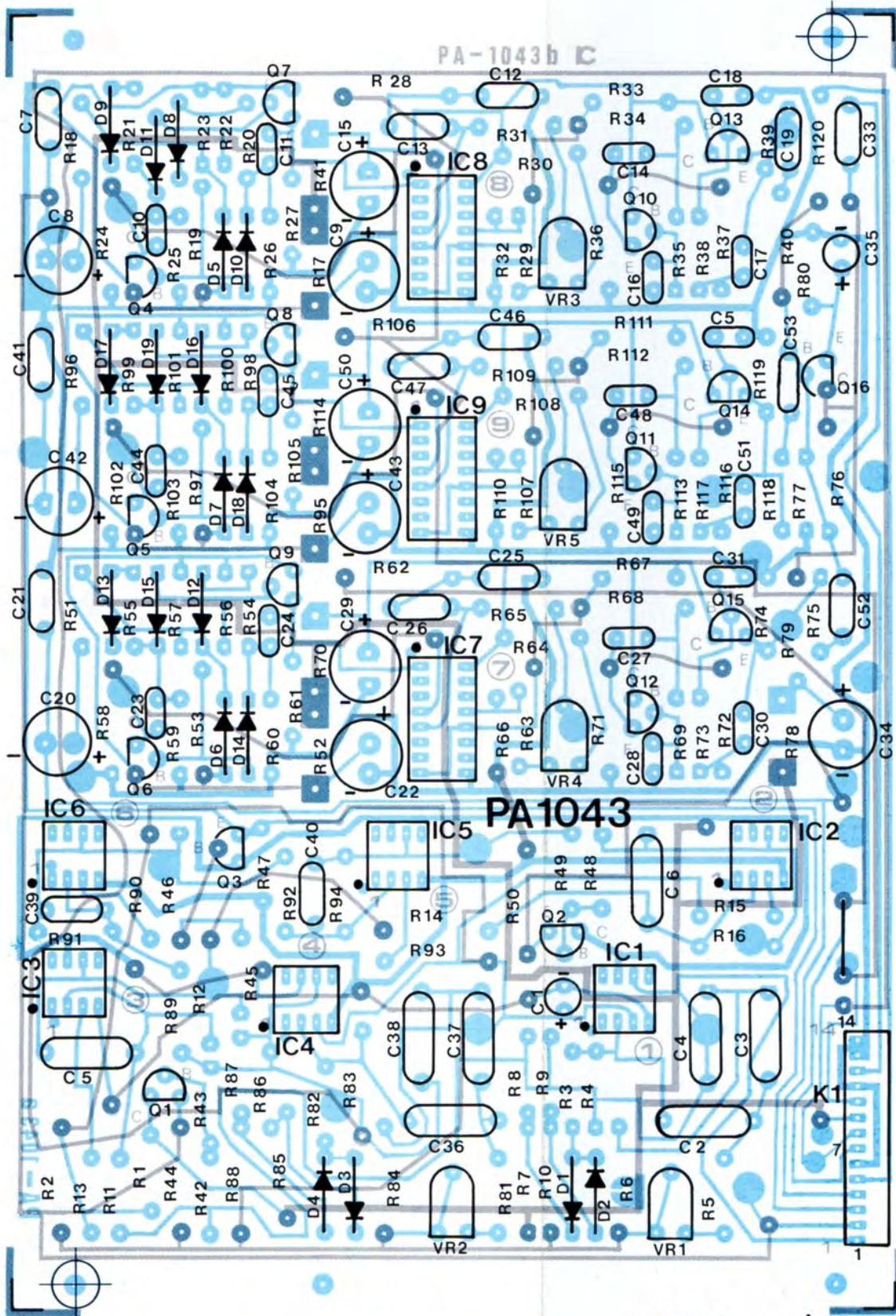

PA 1043/1



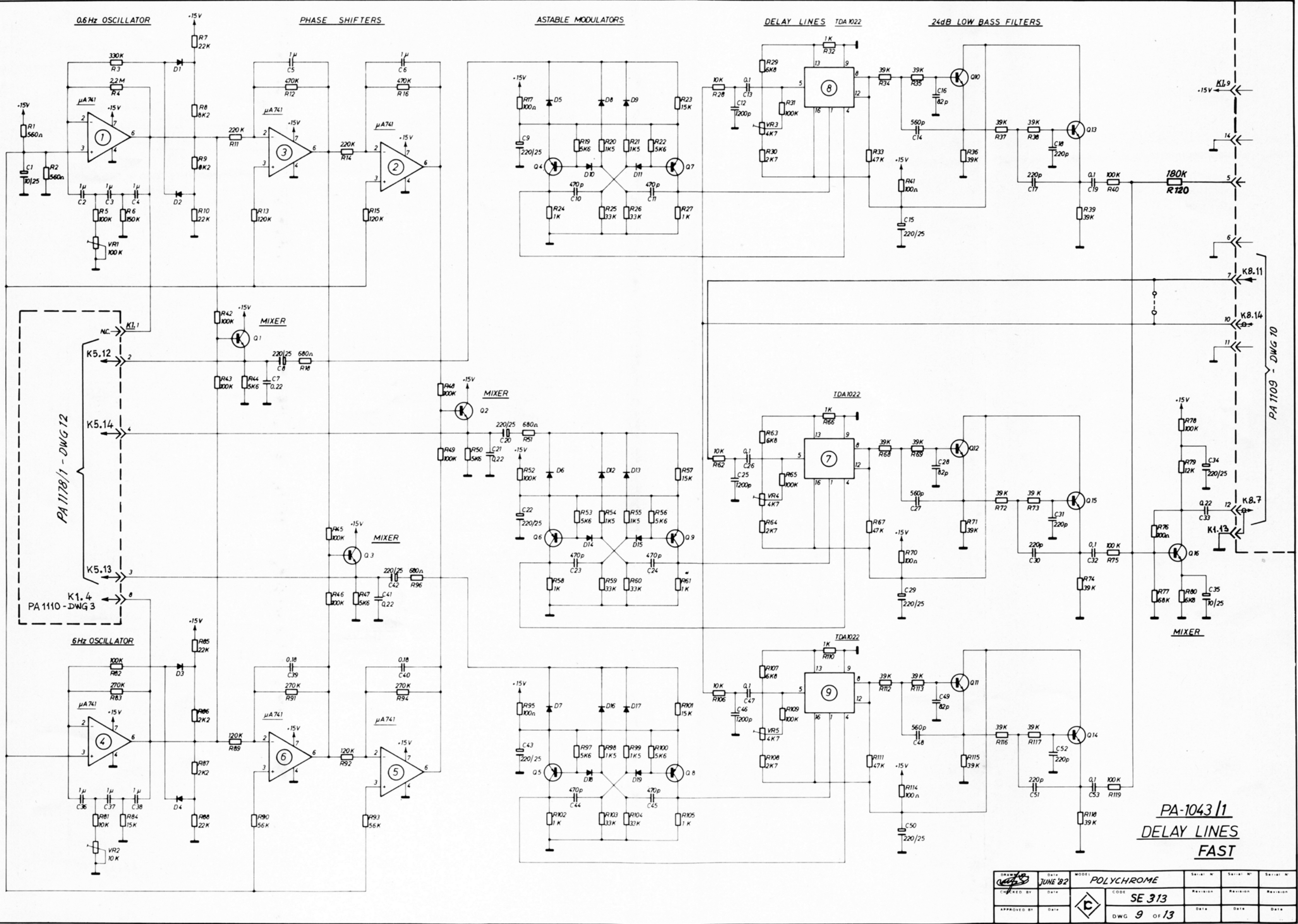

PA-1043/1  
 DELAY LINES  
 FAST

DRAWN BY	DATE	MODEL	SHEET #	SHEET #	SHEET #
DESIGNED BY	JUNE '82	POLYCHROME			
APPROVED BY		CODE	SE 313	REVISION	REVISION
		DWG	9 OF 13	DATE	DATE

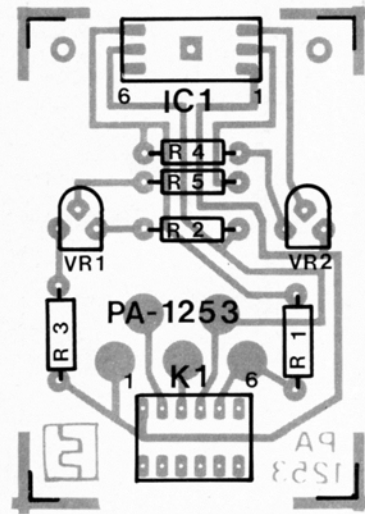

PA-1253

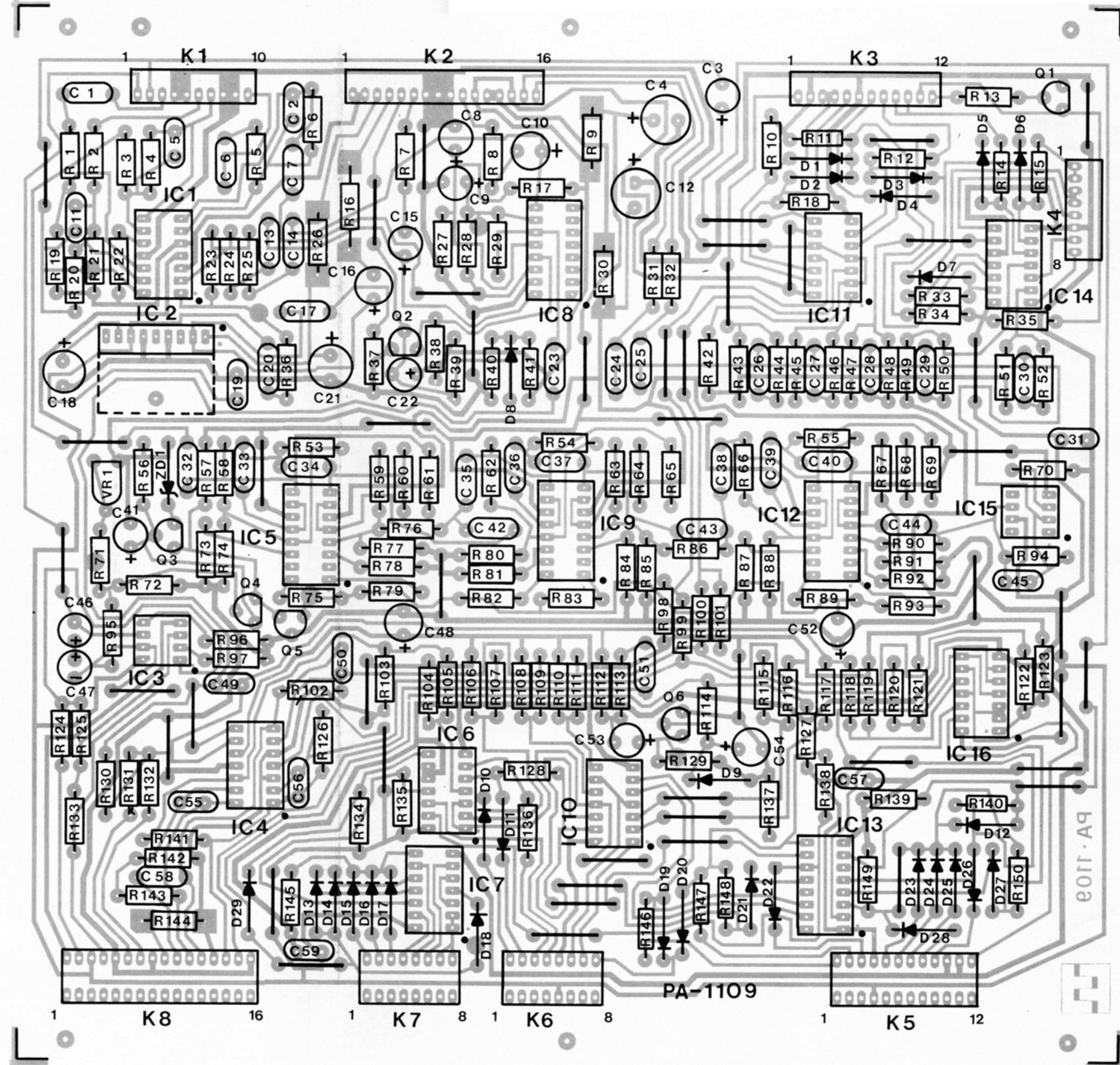

PA-1109



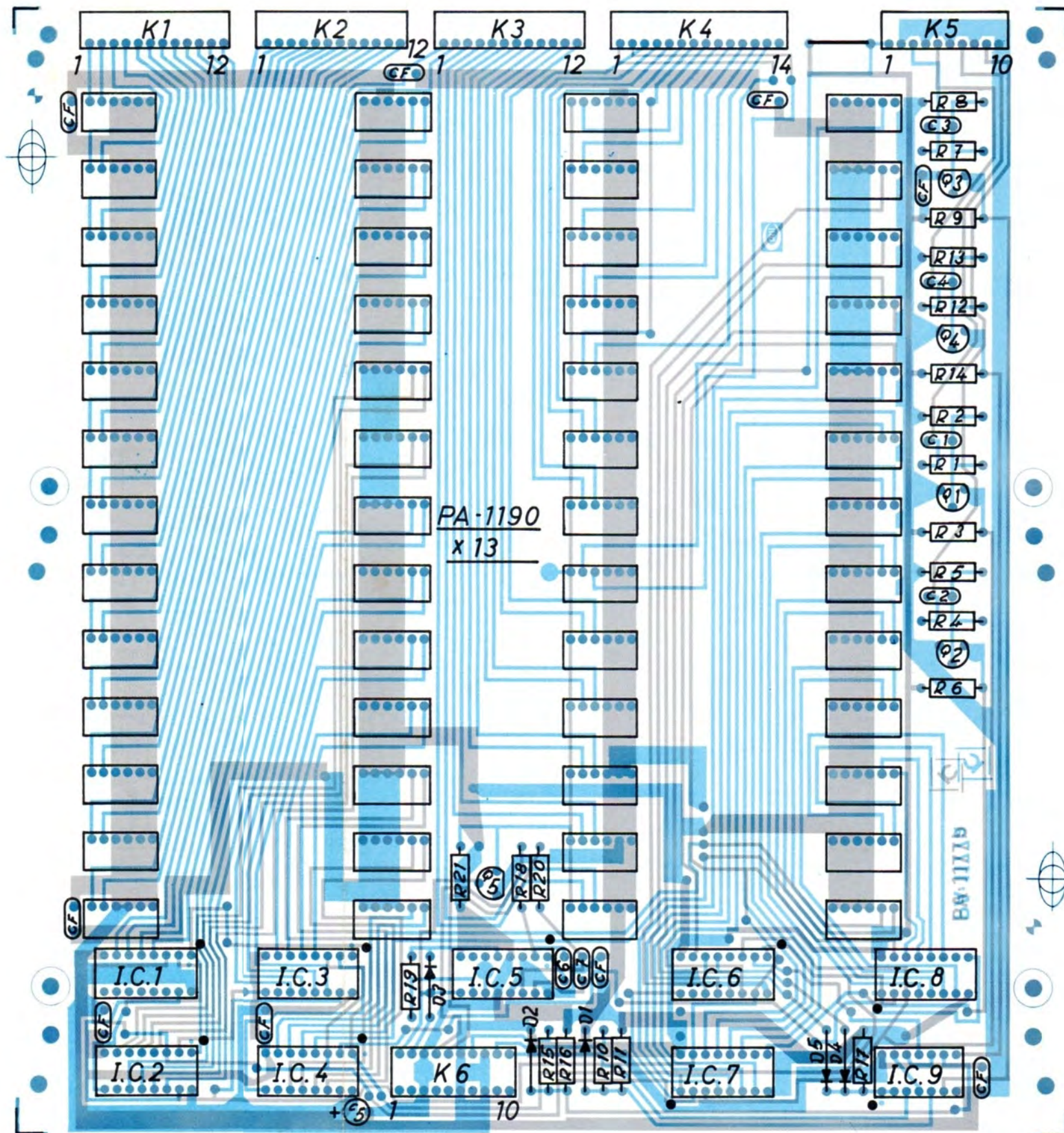

PA-1177/1

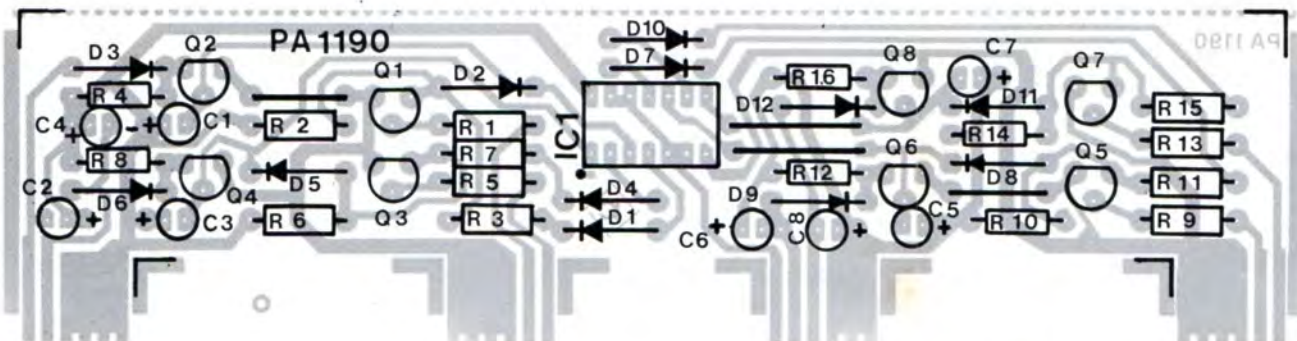
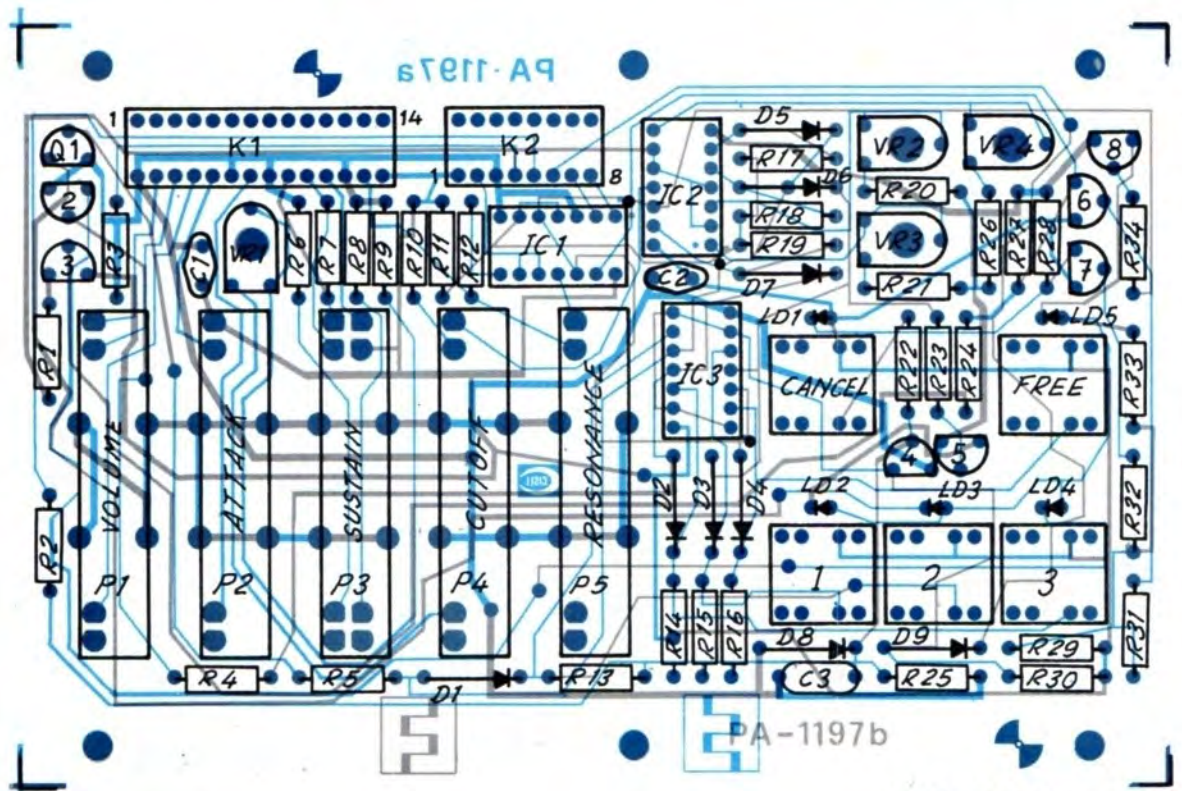

S.P. CONVERTERS

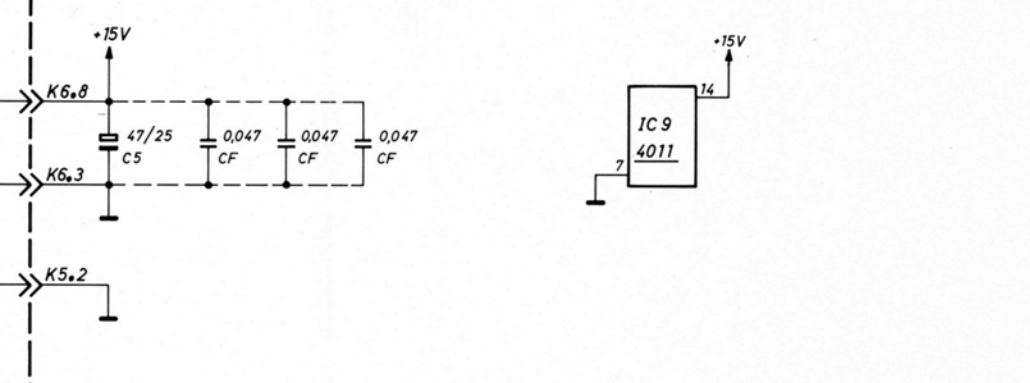
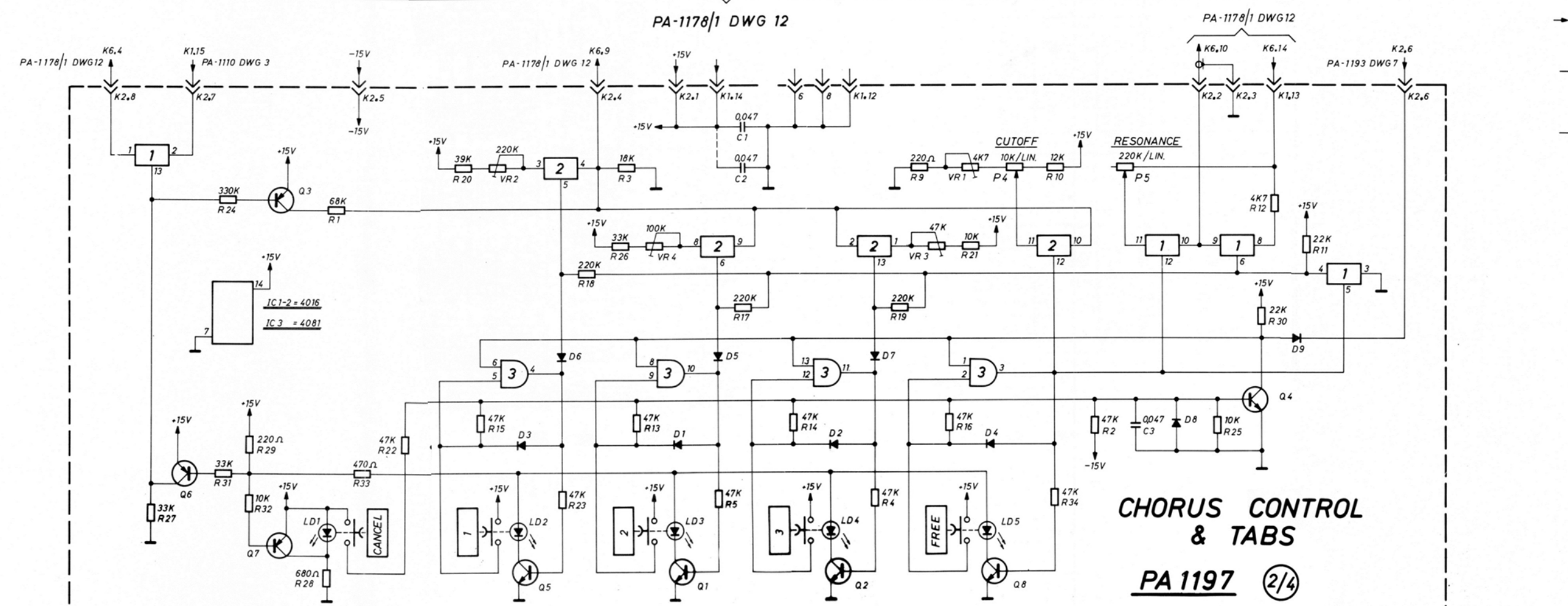
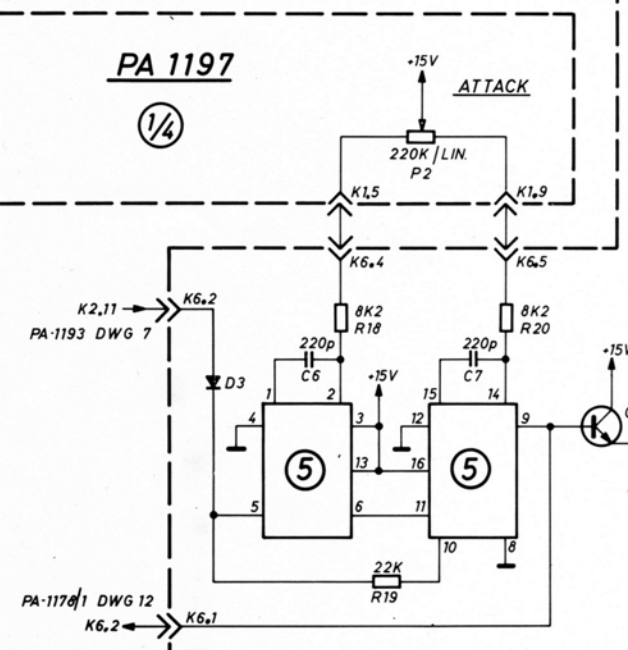
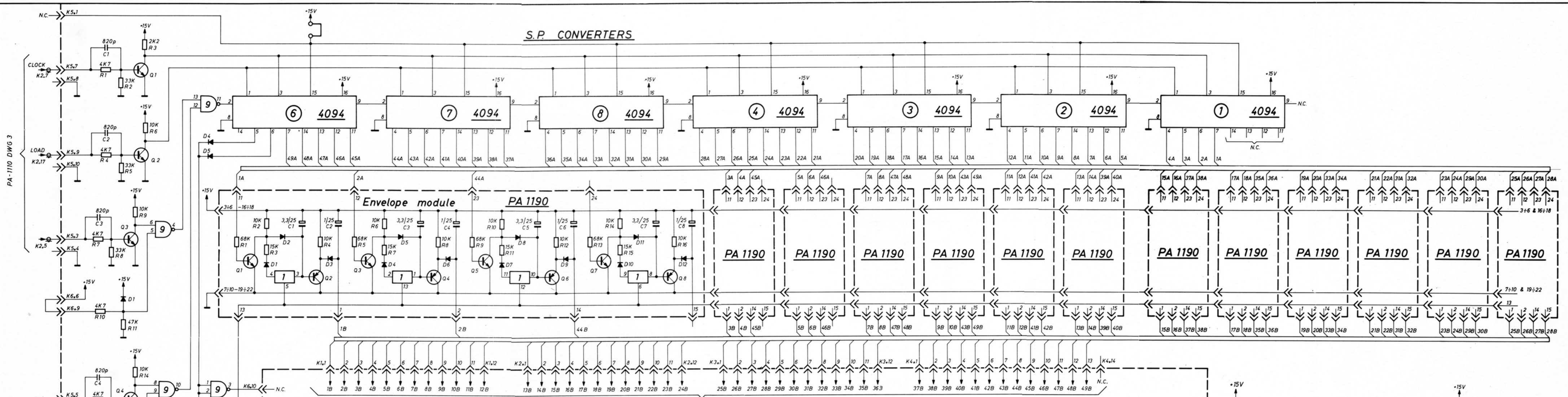

Drawn by <i>WAE</i>	Date MAY '82	Model POLYCHROME	Serial No.	Serial No.	Serial No.
Checked by	Date	Code SE 313	Revision	Revision	Revision
Approved by	Date	DWG 11 OF 13	Date	Date	Date

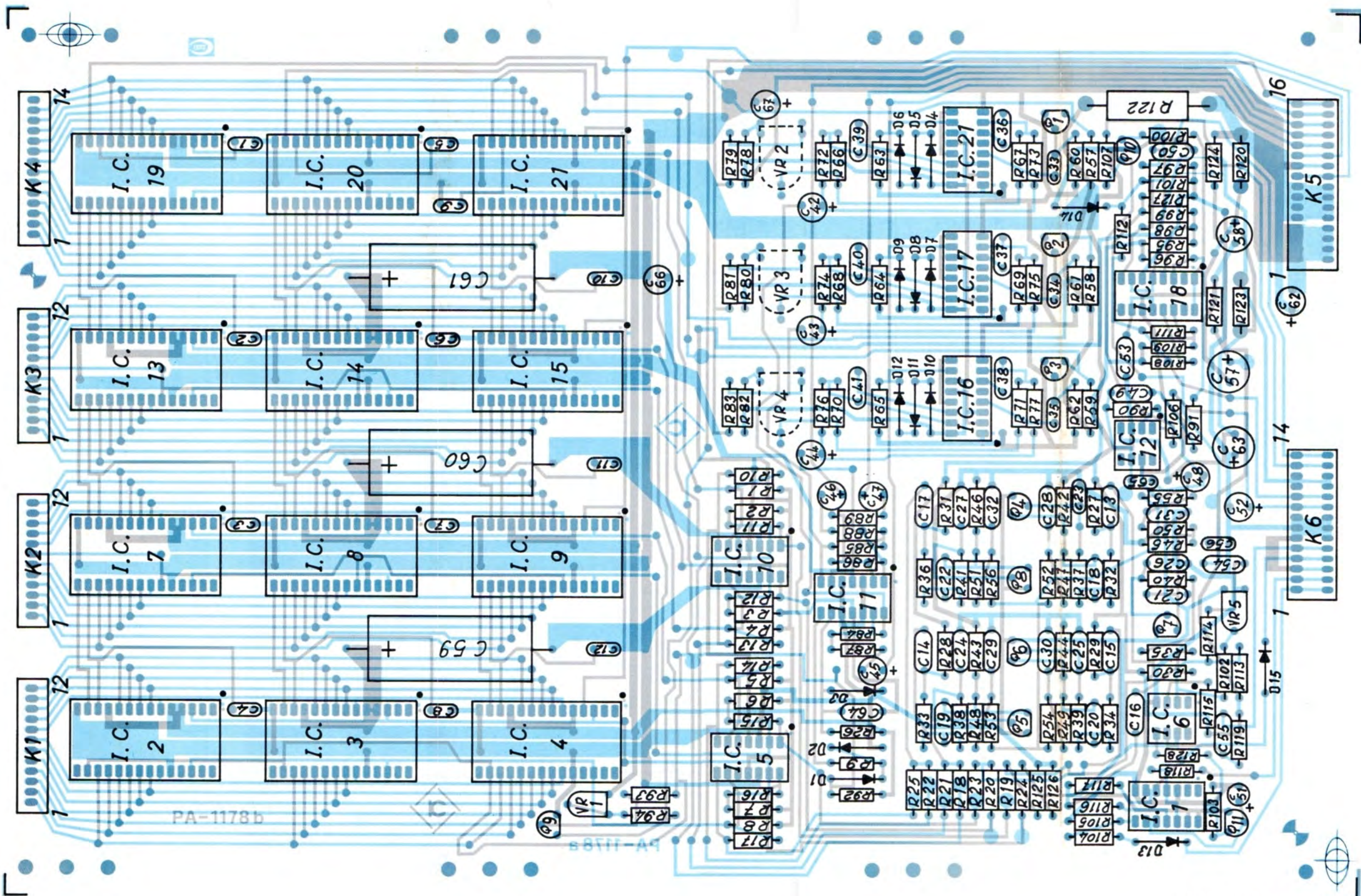

PA-1178b

PA-1178b

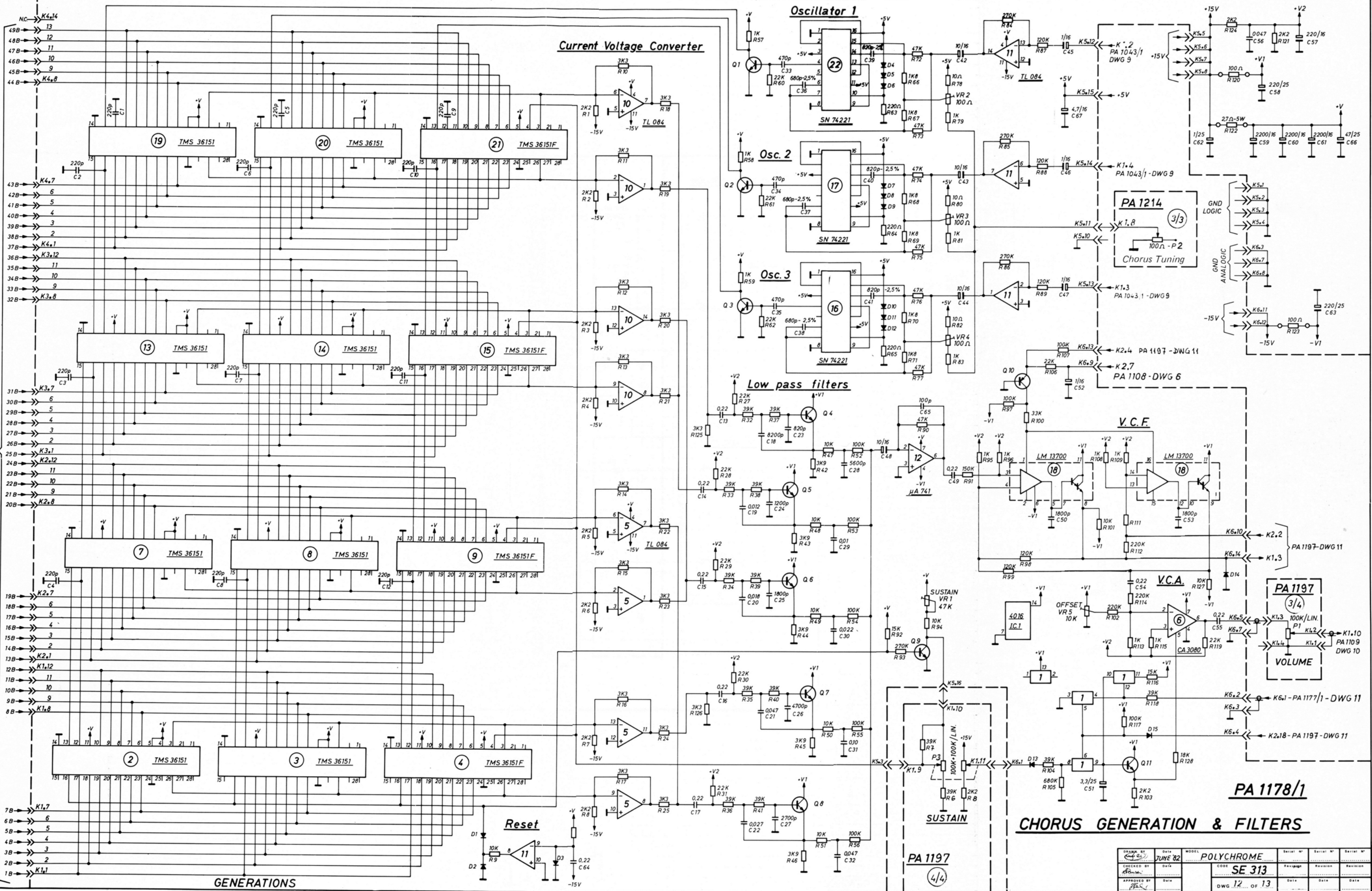

GENERATIONS

Current Voltage Converter

Oscillator 1

Osc. 2

Osc. 3

Low pass filters

V.C.F.

V.C.A.

CHORUS GENERATION & FILTERS

PA 1178/1

PA 1197

(4/4)

DESIGNED BY	DATE	MODEL	SHEET #	SERIAL #	SERIAL #
CHECKED BY	DATE	CODE	REVISION	REVISION	REVISION
APPROVED BY	DATE	DWG. 12 OF 13			



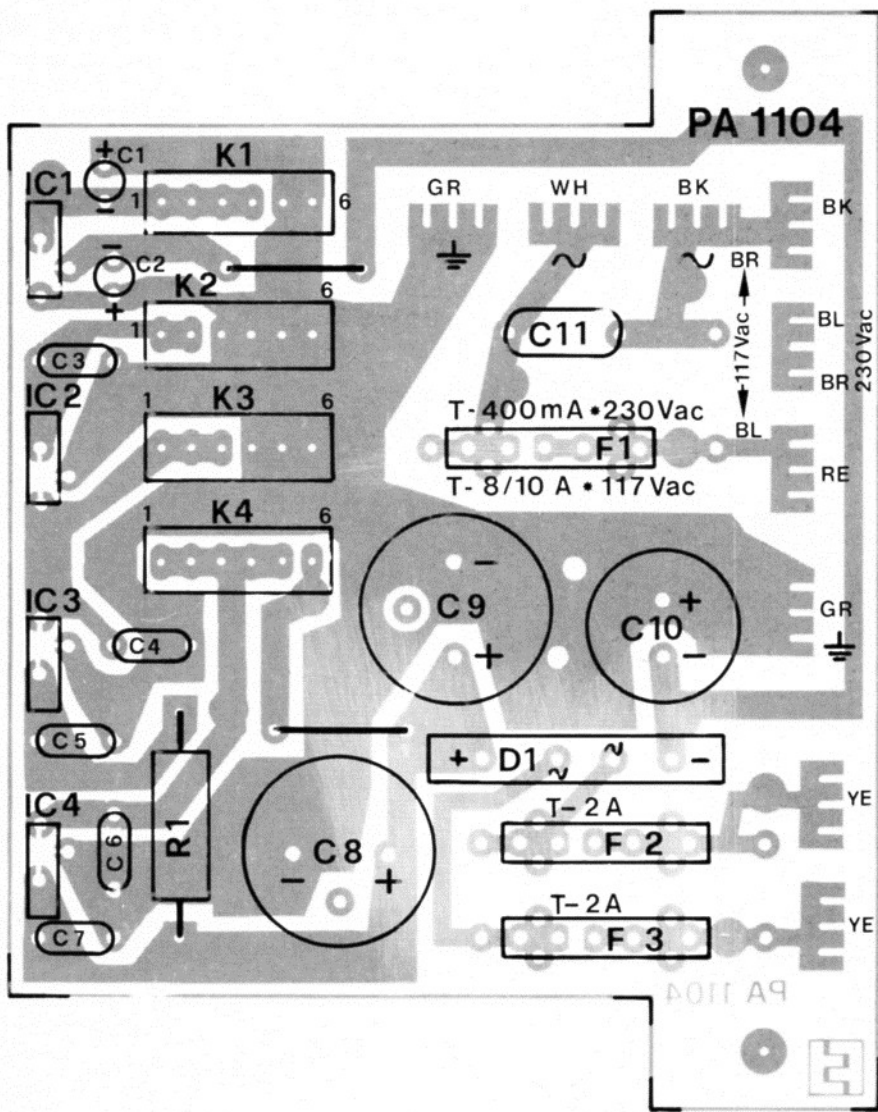

EUROPE VERSION

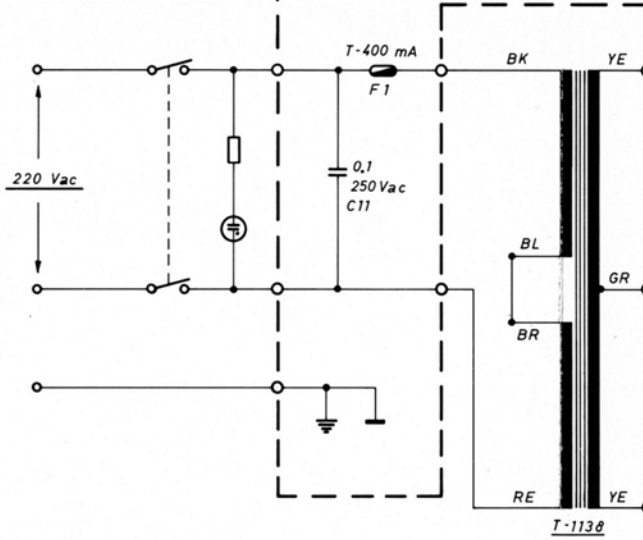

AMERICA VERSION

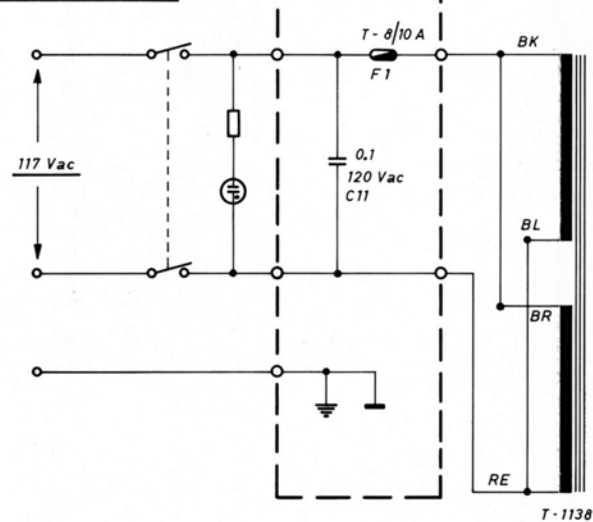

STABILIZER PA-1104

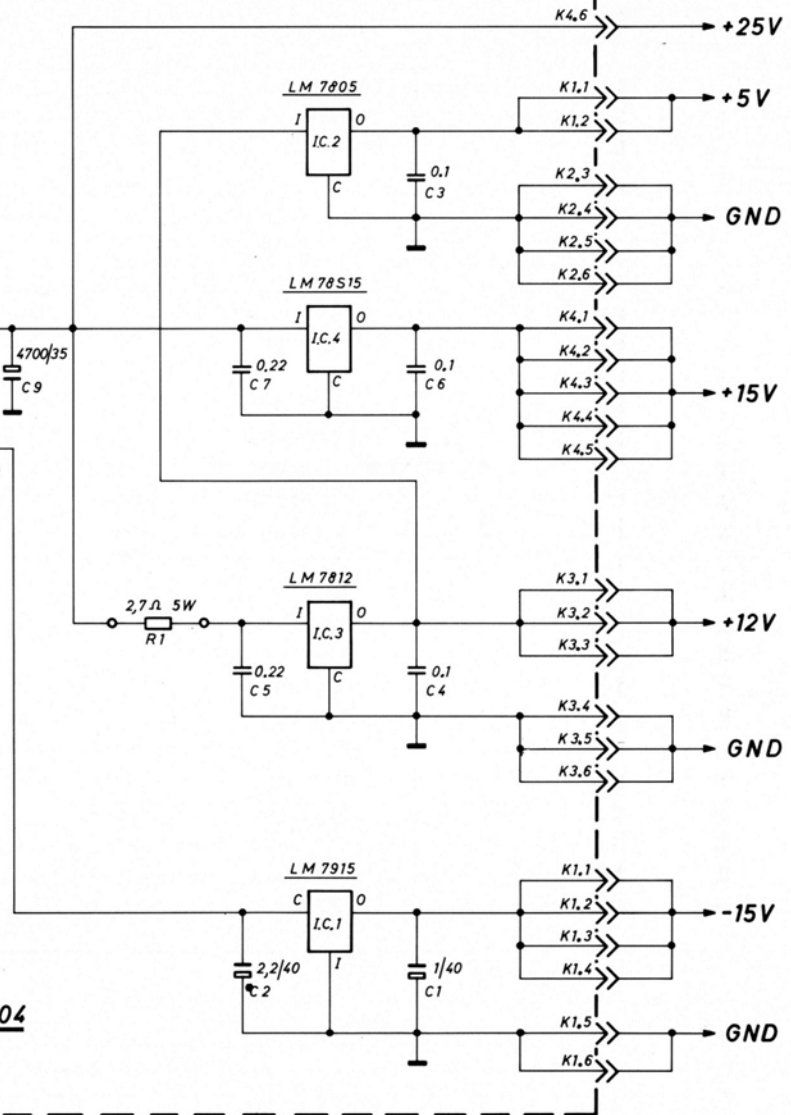

Drawn by <i>[Signature]</i>	Date MAY '82	Model <b>POLYCHROME</b>	Serial No	Serial No	Serial No
Checked by <i>[Signature]</i>	Date	Code <b>SE-313</b>	Revision	Revision	Revision
Approved by <i>[Signature]</i>	Date	DWG. <b>13</b> OF <b>13</b>	Date	Date	Date

## TARATURE

## ADJUSTMENTS

Tutte le tarature sono eseguite in fabbrica perciò non sono necessarie ulteriori regolazioni. Qualsiasi intervento all'interno dello strumento dovrà essere compiuto da tecnici specializzati.

All the adjustments are performed at the factory, therefore further adjustments are not necessary. Any work inside the organ must be performed by specialized technicians.

### PA 1105 - DWG 2

- VR1 (1 Kohm) Con un voltmetro sul pin 4 dell'IC 1, si regola l'OFFSET per una tensione di Zero Volt.
- VR2 (1 Kohm) Con un voltmetro sul pin 4 dell'IC 1, pigiando sulla tastiera in modo da inserire il TOUCH CONTROL, si regola il GAIN per una tensione di 10V max.

- With a voltmeter connected to pin 4 of IC 1, adjust the OFFSET to obtain a voltage of "O" V.
- Pressing the keys so as to insert the TOUCH CONTROL, adjust the GAIN to obtain a 10V max with a voltmeter connected to pin 4 of IC 1.

### PA 1110 - DWG 3

- VR1 (10 Kohm) Con un voltmetro sul K3.2, si regola per ottenere una tensione di +6V.
- VR2 (4K7) Con un voltmetro sul K3.4, si regola per ottenere una tensione di +9V.
- VR3 (47 Kohm) Utilizzando un oscilloscopio con due sonde applicate sui pin 9 e 3 dell'IC 10, dopo aver inserito il registro SPLIT, si regola affinché pigiando due tasti contigui i dati di scansione escano soltanto da un lato della tastiera.
- VR4 (470 ohm) Lasciando in posizione di riposo il potenziometro del Pitch Bend e dopo aver inserito un voltmetro sul pin 7 dell'IC 18, regolare affinché risulti ZERO volt.
- VR5 (100 ohm) & VR6 (22 Kohm) Posizionare il VR5 al centro ed il potenziometro del Pitch Bend in pos. 0, inserire un voltmetro sul pin 1 dell'IC 18 e regolare il VR 6 per ottenere una tensione di 4,4V. Con il Pitch Bend in pos. - si deve ottenere una tensione di 4V ed in pos. + una tensione di 4,8V. Il VR5 si regola accordando acusticamente l'oscillatore sulla nota LA di 440 Hz.

- Connect a voltmeter to K3.2 and adjust VR 1 until a +6V voltage comes out.
- Connect a voltmeter to K3.4 and adjust VR 2 until a +9V voltage comes out.
- Connect the two oscilloscope probes to pin 9 and pin 3 of IC 10 and insert the SPLIT register: adjust VR 3 so that when two adjoining keys are pressed the scanning data go out from one side of the keyboard only.
- With a voltmeter connected to pin 7 of IC 18 and Pitch Bend pot. at zero position, adjust VR 4 to obtain a voltage of "O" V.
- Set VR5 in the medium position and the Pitch Bend pot. in zero position. Then with a voltmeter connected to pin 1 of IC 18, adjust VR6 to obtain a voltage of +4,4V. When the Pitch Bend pot. is set in the "+" and "-" positions, the voltages of +4,8V and +4V respectively can be obtained. VR5 is adjustable acoustically tuning the oscillator to the "A" note of 440 Hz.

### PA 1106 - DWG 5

- VR1 (10 Kohm) Regola la durata dell'involuppo Percussioni Orchestra.  
Con un voltmetro sul K1.3, regolare fino ad ottenere una tensione di +910 mV.
- VR2 (4K7) Regola la Percussione Decay.  
Con un voltmetro sul K1.2 si deve ottenere una tensione di +1,85 V.
- VR3 (10 Kohm) Regola la durata del comando ripetitivo GUITAR. Con un oscilloscopio sul pin 8 dell'IC 3, regolare per ottenere un "impulso negativo" di 6 msec.
- VR4 (10 Kohm) Regola la tensione di OFFSET del Modulatore TREMOLO.
- VR5 (22 Kohm) Inserire il registro CLASSIC GUITAR e con un voltmetro sull'emitter del Q7, regolare fino ad ottenere una tensione di +9,6V.

- Adjustment of the duration of the Orchestra Percussion envelope.  
With a voltmeter connected to K1.3, adjust VR1 to obtain a +910 mV voltage.
- Adjustment of the Percussione Decay.  
With a voltmeter connected to K1.2 adjust VR2 to obtain a +1,85 V voltage.
- Adjustment of the duration of the GUITAR repetitive control.  
With an oscilloscope connected to pin 8 of IC 3, adjust VR3 to obtain a "Negative pulse" of 6 msec.
- Adjustment of the OFFSET voltage of the TREMOLO Modulator.  
Insert the CLASSIC GUITAR register and with a voltmeter connected to Q7 emitter, adjust VR5 to obtain a +9,6V voltage.

## TARATURE

## ADJUSTMENTS

VR6 (10 Kohm)	Regola il minimo della BRILLANZA PERCUSS. e la minima corrente di polarizzazione dell'IC 8 e IC 11.	Adjustment of the minimum level of the PERCUSS. BRILLIANCE and of the minimum bias current of IC 8 and IC 11.
VR7 (10 Kohm)	Regola l'entità dell'EMPHASIS dei registri CLAVICHORD, CLASSIC GUITAR ed ELECTRIC GUITAR, con il registro FREE in posizione OFF.	Adjustment of the EMPHASIS level of the CLAVICHORD, CLASSIC GUITAR and ELECTRIC GUITAR registers, with the FREE register in OFF position.
<b>PA 1108 - DWG 6</b>		
VR1 (22 Kohm)	Regola il minimo della BRILLANZA ENSEMBLE e la minima corrente di polarizzazione dell'IC 2 e IC 4.	Adjustment of the minimum level of the ENSEMBLE BRILLIANCE and of the minimum bias current of IC 2 and IC 4.
VR2 (10 Kohm)	Con l'oscilloscopio sul pin 14 dell'IC 9, regolare per un "impulso negativo" di 4 msec.	With a oscilloscope connected to pin 14 of IC 9, adjust VR2 to obtain a 4 msec. "negative pulse".
VR3 (4K7)	Con l'oscilloscopio sul collettore del Q9 ed il potenz. P3 (PA 1193) al minimo, regolare affinché risulti Zero volt.	With a oscilloscope connected to Q9 collector and P3 pot. (PA 1193) set to minimum, adjust VR3 so that a Zero voltage is obtained.
VR4 (10 Kohm)	Con l'oscilloscopio sul pin 6 dell'IC 8 e con il potenz. ATTACK - P3 (PA 1193) al minimo, regolare affinché risulti Zero volt.	With a oscilloscope connected to pin 6 of IC 8 and ATTACK pot. P3 (PA 1193) set to minimum, adjust VR4 so that a Zero voltage is obtained.
VR5 (10 Kohm)	Regola la tensione di OFFSET del Modulatore ENSEMBLE V.C.A. Si regola dopo aver inserito un registro della famiglia Ensemble (Brass, Reed o Accordion) e pigiando un tasto.	Adjustment of the OFFSET voltage of the V.C.A. ENSEMBLE Modulator. VR5 can be adjusted after having inserted one of the Ensemble registers (Brass, Reed, Accordion) and by keeping a key in the depressed position.
VR6 (22 Kohm)	Regola il timbro del NOISE.	Adjustment of the NOISE timbre.
<b>PA 1043/3 DWG 8</b>		
VR1 (100 KOhm)	Regolazione fine dell'oscillatore a 0,6 Hz. Inserire l'oscilloscopio al pin 6 dell'IC1 e regolare VR1 fino ad ottenere un periodo di 1,67 sec.	Fine tuning of the 0,6 Hz oscillator. Connect the oscilloscope to pin 6 of IC1 and adjust VR1 until a period of 1,67 sec is obtained.
VR3-4-5 (4K7)	Servono alla polarizzazione delle linee di ritardo (IC8-IC7-IC9). Si regolano affinché tra i centrali dei trimmers e la massa risulti una tensione di + 9V.	Adjustment of the Delay Line Bias (IC8-IC7-IC9). Adjustment should be made until a voltage of + 9V between the wipers of VR3-4-5 and the ground comes out.
<b>PA 1043/1 - DWG 9</b>		
VR1 (100 KOhm)	Regolazione fine dell'oscillatore a 0,6 Hz. Inserire l'oscilloscopio al pin 6 dell'IC1 e regolare VR1 fino ad ottenere un periodo di 1,67 sec.	Fine tuning of the 0,6 Hz oscillator. Connect the oscilloscope to pin 6 of IC1 and adjust VR1 until a period of 1,67 sec is obtained.
VR2 (10 KOhm)	Regolazione fine dell'oscillatore a 6 Hz. Inserire l'oscilloscopio al pin 6 dell'IC4 e regolare VR2 fino ad ottenere un periodo di 167 msec.	Fine tuning of the 6 Hz oscillator. Connect the oscilloscope to pin 6 of IC4 and adjust VR2 until a period of 167 msec. is obtained.
VR3-4-5 (4K7)	Servono alla polarizzazione delle linee di ritardo (IC8-IC7-IC9). Si regolano affinché tra i centrali dei trimmers e la massa risulti una tensione di + 9V.	Adjustment of the Delay Line Bias (IC8-IC7-IC9). Adjustment should be made until a voltage of + 9V between the wipers of VR3-4-5 and the ground comes out.

## TARATURE

## ADJUSTMENTS

**PA 1109 - DWG 10**

VR1 (22 Kohm) Regola la minima corrente di polarizzazione degli integrati IC 5 - IC 9 e IC 12 e la rotazione del circuito PHASER.

Adjustment of the bias minimum current of IC 5, IC 9 and IC 12 and the PHASER circuit rotation.

**PA 1253 - DWG 10 SWELL PEDAL**

VR1 - 2 (1 Kohm) Con il voltmetro sul pin 13 dell'IC 8 nella PA 1109, regolare VR2 per ottenere una tensione massima di +7V ed il VR 1 per una tensione minima di  $+5 \div 5,2V$ .

Connect a voltmeter to pin 13 of IC 8 of PA 1109. Then adjust VR2 in order to obtain a maximum voltage +7V and VR1 in order a minimum voltage of  $+5 \div 5,2V$ .

## SEZIONE CORO

## CHORUS SECTION

**PA 1197 - DWG 11**

VR1 (4K7) Con il registro FREE inserito, regola il minimo del potenz. CUTOFF (P4).  
VR2 (220 Kohm) Regola il timbro del PRESET 1.  
VR3 (47 Kohm) Regola il timbro del PRESET 3.  
VR4 (100 Kohm) Regola il timbro del PRESET 2.

Adjustment of the minimum of the CUTOFF pot. (P4) with FREE register inserted.  
Adjustment of the PRESET 1 timbre.  
Adjustment of the PRESET 3 timbre.  
Adjustment of the PRESET 2 timbre.

**PA 1178/1 - DWG 12**

VR1 (47 KOhm) Regola il massimo SUSTAIN del CORO.  
VR2 (100 Ohm) Taratura dell'oscillatore 1.  
VR3 (100 Ohm) Taratura dell'oscillatore 2.  
VR4 (100 Ohm) Taratura dell'oscillatore 3.  
VR5 (10 KOhm) Premendo un tasto, si regola per avere la minima tensione ai capi della R119.

Adjustment of the CHORUS max SUSTAIN.  
Adjustment of oscillator 1.  
Adjustment of oscillator 2.  
Adjustment of oscillator 3.  
Press a key and then adjust VR5 to obtain the minimum voltage at R119 terminals.

Schem Rif.	Circuit	Type	Part Code
<b>PA 1043/1 FAST DELAY LINES (DWG 9)</b>			
IC1 ÷ IC6	Operational Amplifier	LM 741 CN National	W 1210
IC7-8-9	Bucket Brigade Delay Lines	TDA 1022 Philips	W 1113
Q1-2-3	NPN Transistors	BC 209-B S.G.S.	W 1407
Q4 ÷ Q9	PNP Transistors	BC 416-B Motorola	W 1500
Q10 ÷ Q16	NPN Noise Selection transistors	BC 209-B red dot	W 1413
D1-2-3-4	Diodes	BA 130 Fairchild	B 1003
D5-6-7	Rectifier Diodes	1N 4002 ITT	B 1100
D8 ÷ D19	Diodes	BA 130 Fairchild	B 1003
VR 1	Trimmer 100 Kohm	---	P 1009
VR 2	Trimmer 10 Kohm	---	P 1006
VR 3-4-5	Trimmer 4K7	---	P 1005
<b>PA 1043/3 SLOW DELAY LINES (DWG 8)</b>			
IC 1-2-3	Operational Amplifiers	LM 741 CN National	W 1210
IC 7-8-9	Bucket Brigade Delay Lines	TDA 1022 Philips	W 1113
Q 1-2-3	NPN Transistors	BC 209-B S.G.S.	W 1407
Q 4 ÷ Q9	PNP Transistors	BC 416-B Motorola	W 1500
Q10 ÷ Q16	NPN Noise Selection Transistors	BC 209-B red dot	W 1413
D 1-2-3-4	Diodes	BA 130 Fairchild	B 1003
D5-6-7	Rectifier Diodes	1N 4002 ITT	B 1100
D8 ÷ D19	Diodes	BA 130 Fairchild	B 1003
VR 1	Trimmer 100 Kohm	---	P 1009
VR 3-4-5	Trimmer 4K7	---	P 1005
<b>PA 1104 STABILIZER &amp; FUSES BOARD - EUROPE VERSION (DWG 13)</b>			
IC 1	- 15V Series Stabilizer	LM 7915 CT National	W 1226
IC 2	+ 5V Series Stabilizer	uA 7805 Fairchild	W 1214
IC 3	+ 12V Series Stabilizer	LM 7812 CT National	W 1223
IC 4	+ 15V Series Stabilizer	78S15 CV S.G.S.	W 1248
D 1	Rectifier Bridge	B 80 C 3700/2200 Siemens	B 1209
F 1	Primary Fuse	T - 400 mA	F 3
F 2 - F 3	Secondary Fuses	T - 2 A	F 9
<b>PA 1104/1 STABILIZER &amp; FUSES BOARD - AMERICA VERSION (DWG 13)</b>			
IC 1	- 15V Series Stabilizer	LM 7915 CT National	W 1226
IC 2	+ 5V Series Stabilizer	uA 7805 Fairchild	W 1214
IC 3	+ 12V Series Stabilizer	LM 7812 CT National	W 1223
IC 4	+ 15V Series Stabilizer	78S15 CV S.G.S.	W 1248
D 1	Rectifier Bridge	B 80 C 3700/2200 Siemens	B 1209
F 1	Primary Fuse	T - 8/10 A	F 63
F 2 - F 3	Secondary Fuses	T - 2 A	F 59
<b>PA 1105 KEYSWITCHES &amp; TOUCH CONTROL CIRCUIT (DWG 2)</b>			
IC 1	Hall Effect Linear Integrated Circuit	SAS 231 Siemens	W 1244
D 1 ÷ D 61	Diodes	BA 130 Fairchild	B 1003
VR1 - VR2	Trimmer 1 Kohm	---	P 1003
Supporto per 12 molle	Holder for 12 springs		SU 1013
Supporto per 13 molle	Holder for 13 springs		SU 1014
Molla di contatto	Contact spring		ML 408

Schem Rif.	Circuit	Type	Part Code
<b>PA 1106 PERCUSSIVE FILTERS (DWG 5)</b>			
IC 1-5-7-12	Quad Bilateral Switches	HCF 4016 BE S.G.S.	W 1164
IC 2 - 9	Operational Amplifiers	LM 741 CN National	W 1210
IC 3 - 4 - 10	Quad J-Fet Input Operational Amplifiers	TL 084 CN Texas	W 1235
IC 6	Operat. Transc. Amplifier - Red dot	CA 3080 E R.C.A.	W 1242
IC 8 - 11	Dual Operat. Transc. Amplifiers	LM 13700-N National	W 1245
Q 1 - 2 - 8	NPN Transistors	BC 173 - B ITT	W 1407
Q 3 - 5 - 9 - 11	PNP Transistors	BC 416-B Motorola	W 1500
Q 4 - 7 - 10	NPN Transistors	BC 173-C ITT	W 1410
Q 6	NPN Driver Transistor	BC 337-16 Philips	W 1605
D 1 ÷ D 15	Diodes	BA 130 Fairchild	B 1003
ZD 1	Zener Diode 6,2V - 400mW	ZPD 6,2 ITT	B 1310
ZD 2	Zener Diode 5,6V - 400mW	ZPD 5,6 ITT	B 1309
<b>PA 1108 SOFT FILTERS (DWG 6)</b>			
IC 1 - 8	Operat. Transcond. Amplifiers	CA 3080 E R.C.A.	W 1227
IC 2 - 4	Dual Operat. Transcond. Amplifiers	LM 13700-N National	W 1245
IC 3	Operational Amplifier	LM 741 CN National	W 1210
IC 5 - 6 - 11	Quad Bilateral Switches	HCF 4016 BE S.G.S.	W 1164
IC 7 - 9 - 10	Quad J-Fet Input Operat. Amplifiers	TL 084 CN Texas	W 1235
Q 1 - 2 - 5 - 12	NPN Transistors	BC 173-C ITT	W 1410
Q 3 - 4 - 6 - 8 - 9 - 11	PNP Transistors	BC 416-B Motorola	W 1500
Q 7	NPN Driver Transistor	BC 337-16 Philips	W 1605
Q 10	NPN Transistor	BC 173-B ITT	W 1407
Q 13	White Noise Generation	FARFISA Selection	B 1604
D 1 ÷ D 25	Diodes	BA 130 Fairchild	B 1003
ZD 1 - 2	Zener Diodes 6,2V - 400mW	ZPD 6,2 ITT	B 1310
VR 1 - 6	Trimmers 22 Kohm	---	P 1007
VR 2 - 4 - 5	Trimmers 10 Kohm	---	P 1006
VR 3	Trimmer 4K7	---	P 1005
<b>PA 1109 PHASER - PREAMPLIFIER - HEADPHONE AMPLIFIER &amp; VOLUME CONTROL (DWG 10)</b>			
IC 1 - 4	Quad J-Fet Input Operat. Amplifiers	TL 084 CN Texas	W 1235
IC 2	5W Audio Power Amplifier	TDA 2611 A Philips	W 1229
IC 3	Dual Operational Amplifier	MC 1458 P Texas	W 1246
IC 5 - 9 - 12	Dual Operat. Transcond. Amplifiers	LM 13700-N National	W 1245
IC 6 - 10 - 11 - 14 - 16	Quad Bilateral Switches	HCF 4016 BE S.G.S.	W 1164
IC 7	Quad 2-Input NAND Gate	HCF 4011 BE S.G.S.	W 1150
IC 8	D.C. Volume and Balance Control Circuit	TCA 730-A Philips	W 1249
IC 13	Buffered Hex Inverter	F 4049 BCP Fairchild	W 1155
IC 15	Operational Amplifier	LM 741 CN National	W 1210
Q 1	NPN Transistor	BC 173-B ITT	W 1407
Q 2 - 4 - 5	PNP Transistors	BC 416-B Motorola	W 1500
Q 3 - 6	NPN Transistors	BC 173-C ITT	W 1410
D 1 ÷ D 29	Diodes	BA 130 Fairchild	B 1003
ZD 1	Zener Diode 6,2V - 400mV	ZPD 6,2 ITT	B 1310
VR 1	Trimmer 22 Kohm	---	P 1007

Schem Rif.	Circuit	Type	Part Code
<b>PA 1110</b>			
<b>GENERATION &amp; SCANNING LOGIC (DWG 10)</b>			
IC 1 - 18	Dual Operat. Amplifiers	MC 1458 P Texas	W 1246
IC 2 - 6	Dual 4-Bit Binary Counter	F 4520 BPC Fairchild	W 1163
IC 3	He D Flip-Flop	F 40174 BPC Fairchild	W 1161
IC 4 - 5	Quad Exclusive-OR Gate	HCF 4030 BE S.G.S.	W 1174
IC 7 - 12	Dual Retrigger. Resett. Monostable Multivibr.	CD 4098 BE R.C.A.	W 1159
IC 8 - 16	Quad 2-Input AND Gate	CD 4081 BE R.C.A.	W 1156
IC 9 - 27	Quad 2-Input OR Gate	HCF 4071 BE S.G.S.	W 1173
IC 10	Quad Bilateral Switch	CD 4016 BE R.C.A.	W 1164
IC 11	Quad 2-Input NAND Gate	CD 4011 BE R.C.A.	W 1150
IC 13	TTL - Double Monostable	SN 74221 Texas	W 1017
IC 14 - 15	Dual D Flip-Flop	CD 4013 BE R.C.A.	W 1157
IC 17	Hex Inverter	HCF 4069 BE S.G.S.	W 1169
IC 19	Operational Transconductance Amplifier	CA 3080 E R.C.A.	W 1243
IC 20 - 22 - 23 - 25	Buffered Hex Inverter	CD 4049 CN National	W 1155
IC 21	Top Octave Synthetizer	M 086 B1 S.G.S.	W 1111
IC 24 - 26	Decade Counter with 10 Decoder Outputs	HCF 4017 BE S.G.S.	W 1178
IC 28	8-Input Multiplexer with 3-State Outputs	CD 4512 BE R.C.A.	W 1167
Q 1 - 2	NPN Driver Transistors	BC 337-16 Philips	W 1605
Q 3	PNP Transistor	BC 416-B Motorola	W 1500
Q 4 - 7 - 11	NPN Transistors	BC 173-B ITT	W 1407
Q 5 - 6 - 8 - 9	NPN Transistors	BC 173-C ITT	W 1410
Q 10	NPN High Switching Transistor	2N 914 S.G.S.	W 1428
D 1 ÷ D 29	Diodes	BA 130 Fairchild	B 1003
VR 1	Trimmer 10 Kohm	---	P 1006
VR 2	Trimmer 4K7	---	P 1005
VR 3	Trimmer 47 Kohm	---	P 1008
VR 4	Trimmer 470 Ohm	---	P 1002
VR 5	Trimmer 100 Ohm	---	P 1100
VR 6	Trimmer 22 Kohm	---	P 1007
<b>PA 1135</b>			
<b>SOFT GENERATION (DWG 4)</b>			
IC 1 ÷ IC 8	8 Stage Shift/Store Register	HCF 4094 BE S.G.S.	W 1175
IC 9 ÷ IC 21	I <sup>2</sup> L Tecnology Freq. Divider + Keyer	TDA 1008 Philips	W 1018
IC 22	Quad 2 - Input NAND Gate	CD 4011 C National	W 1150
IC 23-24	Quad JFet - Input Operat. Amplif.	TL 084 CN Texas	W 1235
Q 1	PNP Transistor	BC 416-B Motorola	W 1500
Q2-3-4-5-6	NPN Transistors	BC 209-B S.G.S.	W 1407
D2-6-7-8-9-10	Diodes	BA 130 Fairchild	B 1003
<b>PA 1135/1</b>			
<b>PERCUSSION GENERATION (DWG 4)</b>			
IC 1 ÷ IC 8	8 Stage Shift/Store Register	HCF 4094 BE S.G.S.	W 1175
IC 9 ÷ IC 21	I <sup>2</sup> L Tecnology Freq. Divider + Keyer	TDA 1008 Philips	W 1018
IC 22	Quad 2 - Input NAND Gate	CD 4011 C National	W 1150
IC 23-24	Quad JFet - Input Operat. Amplif.	TL 084 CN Texas	W 1235
Q 1	PNP Transistor	BC 416-B Motorola	W 1500
Q2-3-4-5-6	NPN Transistors	BC 209-B S.G.S.	W 1407
D1 ÷ D10	Diodes	BA 130 Fairchild	B 1003
<b>PA 1136</b>			
<b>SOFT ENVELOPE MODULE (DWG 4)</b>			
Q 1 ÷ Q 4	PNP Transistors	BC 416-B Motorola	W 1500
D 1 ÷ D 4	Diodes	BA 130 Fairchild	B 1003
<b>PA 1137</b>			
<b>PERCUSSION ENVELOPE MODULE (DWG 4)</b>			
Q 1 ÷ Q 4	PNP Transistors	BC 416-B Motorola	W 1500
D1 ÷ D20	Diodes	BA 130 Fairchild	B 1003



Schem Rif.	Circuit	Type	Part Code
<b>PA 1177/1 CHORUS CONVERSION &amp; SCANNING (DWG 11)</b>			
IC1-2-3-4-6-7-8	8 Stage Shift/Store Register	CD 4094 BE R.C.A.	W 1175
IC 5	Dual Retrigger. Resett. Monost. Multivibr.	4528 Fairchild	W 1159
IC 9	Quad 2-Input NAND Gate	CD 4011 C National	W 1150
Q 1 ÷ Q 5	NPN Transistors	BC 173-B ITT	W 1407
D 1 ÷ D 5	Diodes	BA 130 Fairchild	B 1003
<b>PA 1178/1 CHORUS GENERATION &amp; FILTERS (DWG 12)</b>			
IC 1	Quad Bilateral Switch	4016 Fairchild	W 1164
IC2-3-7-8	Octave Multiple Tone Synthetizer	TMS 3615 NL-BS Texas	W 1126/1
IC13-14-19-20	Octave Multiple Tone Synthetizer	TMS 3615 NL-BS Texas	W 1126/1
IC 5-10-11	Quad JFet - Input Operat. Amplifier	TL 084 CN Texas	W 1235
IC 6	Operational Transconductance Amplifier	CA 3080 E R.C.A.	W 1243
IC 12	Operational Amplifier	LM 741 CN National	W 1210
IC16-17-22	TTL - Double Monostable	SN 74221 Texas	W 1017
IC 18	Dual Operat. Transconductance Amplif.	LM 13700-N National	W 1245
IC4-9-15-21	Octave Multiple Tone Synthetizer	TMS 3615 NL-BS red dot	W 1138/1
Q1-2-3-9-11	NPN Transistors	BC 173-B ITT	W 1407
Q4-5-6-7-8	NPN Noise Selection Transistors	BC 173-B red dot	W 1413
Q 10	PNP Transistor	BC 416-B Motorola	W 1500
D 1 ÷ D 15	Diodes	BA 130 Fairchild	B 1003
VR 1	Trimmer 47 Kohm	---	P 1008
VR2-3-4	Trimmer 100 Ohm	---	P 1100
VR 5	Trimmer 10 Kohm	---	P 1006
<b>PA 1190 ENVELOPE MODULE (DWG 11)</b>			
IC 1	Quad Bilateral Switch	4016 Fairchild	W 1164
Q 1-3-5-7	NPN Transistors	BC 173-B ITT	W 1407
Q 2-4-6-8	PNP Transistors	BC 416-B Motorola	W 1500
D 1 ÷ D 12	Diodes	BA 130 Fairchild	B 1003
<b>PA 1192 PERCUSSIVE CONTROLS &amp; TABS (DWG 5-7)</b>			
IC1-2	Quad 2-Input AND Gate	CD 4081 BE RCA	W 1156
Q1 ÷ Q6	NPN Transistors	BC 173-B ITT	W 1407
D1 ÷ D8	Diodes	BA 130 Fairchild	B 1003
LD1 ÷ LD8	Led - Red Color	3212R LITON	B 1616
P1 (DWG5)	Volume Pot.	100 Kohm/lin.	P 2509
P2-P3-P4 (DWG5)	Brilliance-Emphasis Pot.	10 Kohm/lin.	P 2506
Interruttore	- Switch	---	X 1706
Coperchio per tastino	- Cap for pushbutton	---	CP 656
Capsula azzurra	- Blue Cap	---	CA 135/5
Capsula grigia	- Grey Cap	---	CA 135/1
Capsula bianca	- White Cap	---	CA 135/2
<b>PA 1193 STRINGS CONTROLS &amp; TABS (DWG 6-7)</b>			
IC1	Buffered Hex Inverters	HCF 4049 UBE S.G.S.	W 1155
Q1 ÷ Q4	PNP Transistors	BC 416-B Motorola	W 1500
D1-D3 ÷ D9	Diodes	BA 130 Fairchild	B 1003
D2	Rectifier Diode	1N 4002 IR	B 1100
LD1 ÷ LD3	Led - Red Color	3213R LITON	B 1616
P1 - P4 (DWG6)	Volume & Release Pot.	10 Kohm/lin.	P 2506
P2 - P3 (DWG6)	Brilliance & Attack Pot.	100K + 100Kohm/lin.	P 2900
Interruttore	- Switch	---	X 1706
Coperchio per tastino	- Cap for pushbutton	---	CP 656
Capsula col. giallo	- Yellow cap	---	CA 135/6

Schem Rif.	Circuit	Type	Part Code
<b>PA 1194</b>			
<b>ENSEMBLE CONTROLS &amp; TABS (DWG 6-7)</b>			
IC1	Quad 2-Input AND Gate	CD 4081 BE RCA	W 1156
Q1 ÷ Q5	NPN Transistors	BC 173-B ITT	W 1407
D1 ÷ D5	Diodes	BA 130 Fairchild	B 1003
LD1 ÷ LD4	Led - Red Color	3213R LITON	B 1616
P1	Volume Pot.	100Kohm/lin.	P 2509
P2-P4-P5	Brilliance-Sustain-Emphasis Pot.	10Kohm/lin.	P 2506
P3	Attack Pot.	220Kohm/lin.	P 2510
Interruttore	- Switch	---	X 1706
Coperchio per tastino	- Cap for pushbutton	---	CP 656
Capsula col. rosso	- Red Cap	---	CA 135/3
Capsula col. bianco	- White Cap	---	CA 135/2
<b>PA 1195</b>			
<b>PHASER CONTROLS &amp; MODULATION TABS (DWG 5-7-10)</b>			
IC1-2	Buffered Hex Inverters	HCF 4049 UBE S.G.S.	W 1155
Q1 ÷ Q12	PNP Transistors	BC 416-B Motorola	W 1500
D1	Rectifier Diode	1N 4002 IR	B 1100
D2 ÷ D13	Diodes	BA 130 Fairchild	B 1003
LD1 ÷ LD8	Led - Red Color	3213R LITON	B 1616
P1-P2 (DWG10)	Volume & Emphasis Pot.	10Kohm/lin.	P 2506
P3 (DWG10)	Speed Pot.	220Kohm/lin.	P 2510
P4 (DWG5)	Tremolo Pot.	10Kohm/lin.	P 2506
Interruttore	- Switch	---	X 1706
Coperchio per tastino	- Cap for pushbutton	---	CP 656
Capsula col. azzurro	- Blue Cap	---	CA 135/5
Capsula col. giallo	- Yellow Cap	---	CA 135/6
Capsula col. rosso	- Red Cap	---	CA 135/3
<b>PA 1196</b>			
<b>GENERAL CONTROLS &amp; TABS (DWG 7)</b>			
IC1	Buffered Hex Inverters	HCF 4049 UBE S.G.S.	W 1155
Q1-Q4-Q5	NPN Transistors	BC 173-B ITT	W 1407
Q2-Q3-Q6	PNP Transistors	BC 416-B Motorola	W 1500
D1 ÷ D10	Diodes	BA 130 Fairchild	B 1003
LD1 ÷ LD7	Led - Red Color	3213R LITON	B 1616
Interruttore	- Switch	---	X 1706
Coperchio per tastino	- Cap for pushbutton	---	CP 656
Capsula col. grigio	- Grey Cap	---	CA 135/1
Capsula col. bianco	- White Cap	---	CA 135/2
<b>PA 1197</b>			
<b>CHORUS CONTROLS &amp; TABS (DWG 11-12)</b>			
IC1-2	Quad Bilateral Switches	HCF 4016 BE S.G.S.	W 1164
IC3	Quad 2-Input AND Gate	CD 4081 BE RCA	W 1156
Q1-Q2-Q4-Q5-Q8	NPN Transistors	BC 173-B ITT	W 1407
Q3-Q6-Q7	PNP Transistors	BC 416-B Motorola	W 1500
D1 ÷ D9	Diodes	BA 130 Fairchild	B 1003
LD1 ÷ LD5	Led - Red Color	3213R LITON	B 1616
VR1	Trimmer 4K7	---	P 1005
VR2	Trimmer 220Kohm	---	P 1010
VR3	Trimmer 47Kohm	---	P 1008
VR4	Trimmer 100Kohm	---	P 1009
P1 (DWG1)	Volume Pot.	100Kohm/lin.	P 2509
P2-P5 (DWG12)	Attack & Resonance Pot.	220Kohm/lin.	P 2510
P3 (DWG11)	Sustain Pot.	100Kohm/lin.	P 2900
P4 (DWG12)	Cutoff Pot.	10Kohm/lin.	P 2506
Interruttore	- Switch	---	X 1706
Coperchio per tastino	- Cap for pushbutton	---	CP 656
Capsula col. bianco	- White Cap	---	CA 135/2
Capsula col. grigio	- Grey Cap	---	CA 135/1
Capsula col. verde	- Green Cap	---	CA 135/4

Schem Rif.	Circuit	Type	Part Code
<b>PA 1214</b>	<b>SPLIT MEMORY &amp; PITCH (DWG 3-11)</b>		
P1-P2	Pitch & Chorus Tuning Pot.	100 ohm/lin.	P 6014
Tastino rosso	- Red Pushbutton	---	TS 402/29
Diffusore per tastino	- Cap for tab	---	RP 622
Interruttore	- Switch	---	X 1705
L1	- Lamp 15V - 30mA	---	LL 18
<b>PA 1253</b>	<b>SWELL PEDAL (DWG 10)</b>		
IC1	Hall Effect Linear I.C.	SAS 231 Siemens	W 1244
VR1-VR2	Trimmers 1 Kohm	---	P 1003
	<b>SUNDRY LIST</b>		
DWG 13	Transformer	---	T 1138
DWG 7	3 Pos. Switches	---	X 1002
Po1 (DWG 10)	Sensitivity Pot.	100Kohm/lin.	P 6006
Po2 (DWG 11)	Pitch Bend Pot.	1Kohm/lin.	P 6702
DWG 13	Interruttore rete - Mains Switch	Europe Version	X 1502
DWG 13	Interruttore rete - Mains Switch	America Version	X 1500
Connettore 5 poli DIN	- 5 Poles DIN Socket	---	I 194
Jack Stereo	- Stereo jack	---	I 173
Jack con interruttore	- Jack with switch	---	I 174
Zoccolo per circuito integrato a 14 piedini	- 14 pin I.C. Socket		I 160
Zoccolo per circuito integrato a 16 piedini	- 16 pin I.C. Socket		I 164
Zoccolo per circuito integrato a 28 piedini	- 28 pin I.C. Socket		I 151

Descrizione	Description	Part Code
Mobile legno	Wooden cabinet	MOB 187
Coperchio superiore completo	Complete top cover	SEM 9044
Leggio	Music rack	DE 666
Boccola riferim. riporto	Holder bushing	BC 592
Riporto per fissaggio leggio	Insert fixing music rack	RP 606
Placca decorativa registri	Register holding plate	PL 631/1
Cantonale anteriore decorativo	Front decoration	CN 932/1
Coperchio posteriore	Back cover	CP 650/1
Pomello per coperchio post.	Knob for back cover	PM 45
Manopola per pot. Pitch Bend	Pitch Bend pot. knob	MP 69
Manopola per pot. a slitta	Slider pot. knob	MP 72/1
Manopola per pot. Pitch e Tuning	Pitch & Tuning pot. knob	MP 71/2
Calotta copricapezz. sinistra	Left cheekblock cover	CL 571/1
Calotta copricapezz. destra	Right cheekblock cover	CL 570/1
Sostegno laterale per telaio porta c.s.	Side holder for p.c.b. frame	SO 343
Gambo destro	Right leg	GM 114
Gambo sinistro	Left leg	GM 115
Gruppo fiancata trasversale	Leg holding bar group	SOG 350
Pomolo per fissaggio gambi	Knob fixing leg to cabinet	PM 43/1
Riporto per fissaggio gambi al mobile	Insert fixing leg to cabinet	RP 619
Pedale espressione magnetico	Magnetic swell pedal	SEM 383
Calotta decorativa inferiore	Lower cover	CL 569
Supporto inferiore	Lower holder	SU 1017
Calotta superiore	Upper cover	CL 568
Tastino comando commutatore	Switch control tab	TS 385
<b>TASTIERA</b>	<b>KEYBOARD</b>	
Tasto "DO"	Key "C"	TST 6432
Tasto "RE"	Key "D"	TST 6433
Tasto "MI"	Key "E"	TST 6434
Tasto "FA"	Key "F"	TST 6435
Tasto "SOL"	Key "G"	TST 6436
Tasto "LA"	Key "A"	TST 6437
Tasto "SI"	Key "B"	TST 6438
Tasto "DO" finale	Final Key "C"	TST 6440
Tasto "Diesis"	Sharp Key	TST 6442

**IMPORTANT:** IN ANY CORRESPONDENCE CONCERNING THIS INSTRUMENT ALWAYS INCLUDE MODEL AND SERIAL NUMBERS!

PARTS ORDERING — When ordering parts be sure to include the following information:

1. Model and serial Number of instrument.
2. Part Code.
3. A description of the Part.
4. Specify how you want the part shipped.

FARFISA COMPANY - WHOSE POLICY IS CONSTANTLY DIRECTED TO IMPROVEMENTS AND NEW DEVELOPMENTS - RESERVES THE RIGHT TO CHANGE SPECIFICATIONS, DESIGNS, PRICES, MODELS AND TO DISCONTINUE MODELS WITHOUT NOTICE AND LIABILITY.



FARFISA S.p.A. / Musical Instruments / P. O. Box 204 / 60100 Ancona / Italy