

# **SERVICE MANUAL**

# **R - 100**



**HAMMOND ORGAN COMPANY  
DIVISION OF HAMMOND CORPORATION**

1740 N. 25th Avenue • Melrose Park, Ill. 60160

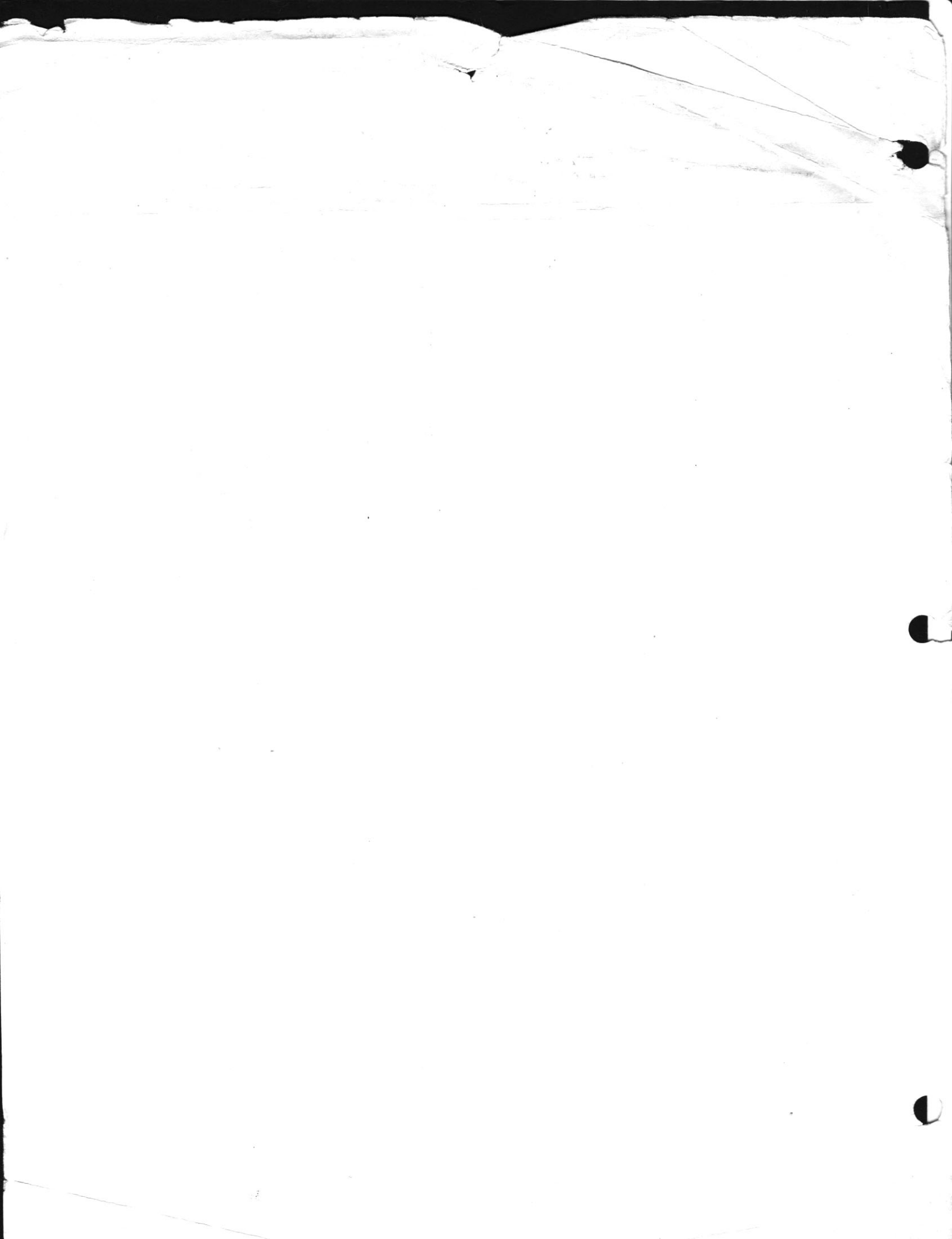

## TABLE OF CONTENTS

	<i>Page</i>
<b>INTRODUCTION</b> .....	iv
<b>SPECIFICATIONS</b> .....	iv
<b>SECTION I – How the Organ Operates</b>	
1-1. General .....	1-1
1-2. Tone Source .....	1-1
1-3. Manuals .....	1-1
1-4. Upper Manual .....	1-1
1-5. Lower Manual .....	1-1
1-6. Pedals .....	1-1
1-7. Drawbars .....	1-1
1-8. Leslie Speaker .....	1-1
1-9. Percussion .....	1-2
1-10. Harp Effects .....	1-2
1-11. Add Leslie Tab .....	1-2
1-12. Headphone Jack .....	1-2
1-13. Phono Input .....	1-2
1-14. Swell Pedal .....	1-2
1-15. Tone Cabinet Outlet .....	1-2
1-16. Music Illumination .....	1-2
1-17. Cymbal/Brush Volume Control .....	1-2
<b>SECTION II – THEORY OF OPERATION</b>	
2-1. General .....	2-1
2-2. Tone Generator .....	2-1
2-3. Manuals .....	2-1
2-4. Harmonic Drawbars .....	2-4
2-5. Pedal Keyboard .....	2-4
2-6. Pedal Drawbars .....	2-4
2-7. Pedal Switch .....	2-7
2-8. Harp Section .....	2-7
2-9. Cymbal and Brush Generator Board .....	2-9
2-10. Percussion and Reiteration Drives .....	2-9
2-11. Percussion Gate Amplifier .....	2-10
2-12. Alternate Percussion Gate Amplifier .....	2-10
2-13. Preamplifier Board .....	2-11
2-14. Active Filters Board .....	2-12
2-15. Sine Wave Amplifier Boards .....	2-12
2-16. Pedal Keyer Boards .....	2-13
2-17. Pedal Preamplifier Board .....	2-14
2-18. Swell Pedal Assembly .....	2-14
2-19. Power Amplifier Assembly .....	2-14
2-20. Reverberation Amplifier Assembly .....	2-15
2-21. Power Supply .....	2-16

### SECTION III – Disassembly

3-1.	General	3-1
3-2.	Removal of Organ Top Assembly	3-1
3-3.	Removal of Decorative Wooden Blocks	3-1
3-4.	Removal of Control Assembly	3-1
3-5.	Removal of Upper Manual	3-2
3-6.	Removal of Lower Manual	3-2
3-7.	Removal of Pedal Switch Assembly	3-2
3-8.	Removal of Leslie Unit	3-2
3-9.	Removal of Leslie Two-Speed Motor	3-2
3-10.	Small Motor Disassembly	3-3
3-11.	Large Motor Disassembly	3-3
3-12.	Reassembly of Large and Small Motor	3-3
3-13.	Small Motor Shaft Operation and Adjustment	3-3

### SECTION IV – Maintenance

4-1.	General	4-1
4-2.	Performance Standards	4-1
4-3.	Lubrication	4-1
4-4.	Replacement of Control Tab	4-1
4-5.	Replacement of Upper Manual Playing Key	4-2
4-6.	Replacement of Lower Manual Playing Key	4-2
4-7.	Replacement of Drawbar or Knob	4-2
4-8.	Replacement of Drawbar Assembly	4-2
4-9.	Replacement of Music Illuminator Lamps	4-2
4-10.	Leslie Motor Cleaning and Lubrication	4-2
4-11.	Leslie Drive Belt Adjustment	4-4
4-12.	Maintenance of Leslie Rotary Contact	4-4
4-13.	Practical Service Suggestions	4-5
4-14.	Organ Does Not Play	4-5
4-15.	One Key Does Not Play, or a Harmonic Missing	4-5
4-16.	One Note is Weak	4-6
4-17.	One Pedal Does Not Play	4-6
4-18.	Harp Circuit Ciphers	4-7
4-19.	Brush Does Not Sound	4-7
4-20.	Cymbal Does Not Sound	4-7
4-21.	No Cymbal or Brush	4-8
4-22.	One Harmonic Missing	4-8
4-23.	Preset Voicing	4-8
4-24.	Hum	4-8
4-25.	Parts Location	4-8

### SECTION IV – Diagrams

5-1.	General	5-1
------	---------	-----

### SECTION VI – Parts List

6-1.	Parts List Index	6-1
------	------------------	-----

## LIST OF ILLUSTRATIONS

<i>Figure</i>	<i>Page</i>
<b>Frontispiece. Typical R-100 Organ</b> . . . . .	<b>v</b>
2-1. System Block Diagram. . . . .	2-3
2-2. Magnet Locations on Generator . . . . .	2-4
2-3. Filter Locations on Generator Cover . . . . .	2-5
2-4. Pedal Keyboard . . . . .	2-7
2-5. Harp Keyer Assembly . . . . .	2-8
2-6. Typical Pedal Circuit. . . . .	2-13
3-1. Location of Upper Manual Attachment Screw, Right Front	3-2
3-2. Location of Upper Manual Attaching Screws, Left Front. .	3-2
3-3. Leslie Two-Speed Motor Assembly. . . . .	3-3
4-1. Control Tab Replacement. . . . .	4-2
4-2. Underside of Illuminator . . . . .	4-4
4-3. Illuminator, Cover Open . . . . .	4-4
4-4. Leslie Motor Lubrication and Adjustments. . . . .	4-5
4-5. Mercotac . . . . .	4-5
4-6. Parts Identification, Rear of Console . . . . .	4-9
4-7. Parts Identification and Lubrication Points, Rear of Console. . . . .	4-10
4-8. Parts Identification, Fold-Out Panel . . . . .	4-11
5-1. R-100 Organ, Schematic Diagram . . . . .	5-2/5-4
5-2. R-100 Organ, Wiring Diagram . . . . .	5-5
5-3. Pedal System, Board Layouts and Schematic Diagram. . . .	5-6
5-4. Preamplifier, Layout and Schematic Diagram. . . . .	5-7
5-5. Cymbal/Brush Generator, Layout and Schematic Diagram . . . . .	5-8
5-6. Active Filters, Layout and Schematic Diagram. . . . .	5-9
5-7. Percussion and Reiteration Driver, Layout and Schematic Diagram . . . . .	5-10
5-8. Percussion Gate Amplifier, Board Layout and Schematic Diagram . . . . .	5-11
5-9. Alternate Percussion Amplifier, Board Layout and Schematic Diagram . . . . .	5-12
5-10. Reverberation Amplifier, Layout and Schematic Diagram . . . . .	5-13
5-11. Power Amplifier, Layout and Schematic Diagram . . . . .	5-14
5-12. Power Amplifier, Chassis Wiring Diagram . . . . .	5-15
5-13. Power Supply, Schematic Diagram . . . . .	5-16
5-14. Swell Pedal, Schematic Diagram . . . . .	5-17
5-15. Swell Pedal, Wiring Diagram. . . . .	5-17
5-16. Control Panel Wiring Diagram . . . . .	5-18
5-17. Leslie Switch Assembly, Wiring Diagram . . . . .	5-19
5-18. Pedal Sustain Switch Assembly, Wiring Diagram . . . . .	5-20
5-19. Percussion Switch Assembly No. 1, Wiring Diagram . . . .	5-21
5-20. Percussion Switch Assembly No. 2, Wiring Diagram . . . .	5-22
5-21. Lower Preset Switch Assembly, Wiring Diagram . . . . .	5-23
5-22. Upper Preset Switch Assembly, Wiring Diagram . . . . .	5-24
5-23. Reverberation Switch Assembly, Wiring Diagram . . . . .	5-25
5-24. Harp Keyer and Preamplifier, Schematic Diagram . . . . .	5-26
6-1 . Location of Parts in Leslie Rotary Unit. . . . .	6-16

## LIST OF TABLES

<i>Table</i>	<i>Page</i>
2-1. Generator Frequencies in R-100 Organ. . . . .	2-2
2-2. Frequencies Used in Manuals . . . . .	2-6
4-1. Performance Check and Adjustment Procedures . . . . .	4-3

## INTRODUCTION

This manual contains service information for the R-100 organ.

The R-100 organ uses the familiar Hammond tone wheel generator as a tone source. All frequencies from No. 1 through No. 91 are produced by the generator. Various tone colors are selectable by means of Preset tabs and drawbars mounted on the control panel. Acoustic modulation of the sound output is provided by a Leslie (rotary) speaker. No vibrato is provided.

The organ is equipped with a built-in Rhythm II feature. The circuitry is the same as the Rhythm II in other Hammond models. Service information for Rhythm II will be found in a separate Service Manual, HO-466.

For convenience in locating desired information, this manual is divided into the six sections listed below.

- I How the Organ Operates
- II Theory of Operation
- III Disassembly
- IV Maintenance
- V Diagrams
- VI Parts List

## SPECIFICATIONS

Dimensions: Width 48"; Depth—w/o Pedal Clavier, 29", with Pedal Clavier 44";  
Height, 43", with Music Rack raised 50".

Weight: 390 lbs. w/o Bench

Power Input: 1.1 Amperes @ 120 VAC

Output: 32 watts each channel, I.H.F.M.



Frontispiece. Typical R-100 Organ





# SECTION I

## HOW THE ORGAN OPERATES

- 1-1. GENERAL.**—This section contains a description of the operating controls and their functions.
- 1-2. TONE SOURCE.**—All tones of the organ except Cymbal and Brush originate as electrical signals in the Tone Generator assembly, which contains 91 individual tone wheels. A complete description of Tone Generator operation is given in Section II.
- 1-3. MANUALS.**—The organ is equipped with two manuals of 61 keys each, so arranged that upper manual and lower manual keys in line with each other will produce tones of the same fundamental pitch when corresponding drawbars are pulled out. There are nine drawbars associated with each manual.
- 1-4. UPPER MANUAL.**—In order for the upper manual to play, one of the UPPER PRESET tabs must be depressed. When the DRAWBARS AND PERCUSSION tab alone is depressed, percussion alone, as selected by the PERCUSSION tabs will be heard, unless one or more of the nine UPPER DRAWBARS is pulled out.
- 1-5. LOWER MANUAL.**—In order for the lower manual to play, one or more of the LOWER PRESET tabs must be depressed. If the DRAWBARS tab alone is depressed, one or more of the nine LOWER DRAWBARS must be pulled out in order to produce sound. By depressing the BRUSH LOWER tab the brush voice is added to the lower manual in legato mode; that is, the brush will be heard each time a lower manual key is played, even when other lower manual tabs or drawbars are not activated.
- 1-6. PEDALS.**—The organ is equipped with a 25 note pedal keyboard. Like the manuals, it has black and white keys arranged in standard octave patterns. One or both PEDAL DRAWBARS must be pulled out in order to produce sound.
- Pedal tones are sustainable in any of three selectable degrees by means of the PEDAL SUSTAIN tabs. These tabs are marked STRING BASS I and STRING BASS II. When the CYMBAL PEDAL tab is depressed, the cymbal voice sounds each time a pedal is played, whether drawbars are pulled or not.
- 1-7. DRAWBARS.**—A set of nine drawbars is associated with each manual. By sliding the drawbars in and out, the organist is able to mix the fundamental tones and harmonics in various proportions. The drawbars are calibrated for eight positions (1 through 8), to indicate the relative strength of a particular harmonic, and to enable the organist to repeat his favorite combinations. If a drawbar is pushed in to its limit (position 0), the harmonic it controls will not be present in the mixture. The two PEDAL DRAWBARS control the harmonic content of the pedal tones. The left (16') drawbar gives emphasis to the lower harmonics, the right (8') gives emphasis to the higher harmonics.
- 1-8. LESLIE SPEAKER.**—The R-100 organ is equipped with a two-speed rotary Leslie speaker. The speaker may be programmed in any of the following modes:
- With LESLIE ON UPPER tab depressed, the upper manual tones only will be heard through the Leslie.
  - With LESLIE ON LOWER tab depressed, lower manual tones only will be heard through the Leslie.
  - With both the foregoing tabs depressed, the tones of both manuals will be heard through the Leslie.
  - With the LESLIE CHORUS tab depressed, all organ tones including pedal, will be heard through the Leslie.
  - With the LESLIE ON REVERB tab depressed, reverberated tones will be heard through the Leslie.

- f. When the **ADD LESLIE** tab is depressed, percussion tones are heard through the Leslie.
- 1-9. PERCUSSION.**—Five percussion voices, controlled by tabs, are available to the upper manual (See paragraph 1-4). Any of the voices may be reiterated by depressing the **REITERATE** tab. The reiteration rate is controlled by the organist by means of a **REITERATION RATE** control (potentiometer) mounted to the extreme left of the control panel.
- 1-10. HARP EFFECTS.**—When the **HARP SUSTAIN** tab is depressed, harp effects are played on the upper manual keys, second C (Key No. 13) to highest C only.
- 1-11. ADD LESLIE TAB.**—This tab, when depressed, routes percussion signals to the Leslie speaker.
- 1-12. HEADPHONE JACK.**—A stereo headphone jack is provided. Inserting a headphone plug will silence the organ's speakers and external tone cabinet, if used.
- 1-13. PHONO INPUT.**—A phono input jack is provided for the use of external sound sources. Any source used must have its own volume control, since the swell pedal does not affect inputs to the jack.

A cassette tape recorder when used, has its output connected to this jack.

- 1-14. SWELL PEDAL.**—The swell pedal controls the volume of all sounds produced by the organ as heard through the main speaker, the Leslie, and external tone cabinet, when present.
- 1-15. TONE CABINET OUTLET.**—The organ is equipped with an outlet which permits the use of a Hammond Series 10 Tone Cabinet as an accessory.
- 1-16. MUSIC ILLUMINATION SYSTEM.**—The music illumination system requires the use of 14-volt incandescent lamps. The system is independent of the organ circuitry and has its own power switch, so that it can be turned on, even when the power to the organ circuits is "off."
- The illumination is so arranged that the music rack and Preset tabs are illuminated. Tabs to right and left of Presets are not illuminated.
- 1-17. CYMBAL/BRUSH VOLUME CONTROL.**—A control (potentiometer) mounted to the extreme left of the control panel enables the organist to adjust Cymbal and Brush volume relative to the other tones of the organ.

## SECTION II THEORY OF OPERATION

**2-1. GENERAL.**—In this section the theory of operation of the Tone Generator and each of the circuits in the organ is discussed. Schematic diagrams referenced in this section are contained in section V. For interrelationships of various circuits, see Figure 2-1.

**2-2. TONE GENERATOR.**—All tones of the organ except CYMBAL and BRUSH originate as electrical signals in the tone generator assembly. It contains 91 tone wheels having various numbers of teeth, with suitable gears for driving them at various speeds from the main shaft extending along the center. Each pair of tone wheels is mounted on a shaft, and between them is a bakelite gear held between two coil springs forming a mechanical vibration filter. As the gear is not rigidly attached to the shaft, any pair of wheels which may be stopped accidentally will not interfere with the operation of the others. Adjacent to each tone wheel is a magnetized rod with a pick-up coil wound on it. These magnets extend through the front and back of the generator, and are held by set screws which can be loosened in case adjustment is ever necessary. Figure 2-2 shows where to find the magnet for any frequency number. In the illustration the dotted lines indicate frequencies whose tone wheels are on the same shaft.

On top of the tone generator assembly are small transformers and condensers, forming tuned filters for the higher frequencies. They are not likely to need replacing. In case a filter does become inoperative, both the transformer and capacitor must be replaced with a matched set from the factory. Figure 2-3 shows the locations of the filters.

The output frequencies of the tone generator are numbered, for convenience, in order of increasing frequency. The lowest, number 1, is approximately 32 Hz, and the highest, number 91 is about 6,000 Hz.

In case any generator frequency is weak or absent, refer to paragraph 4-16 for the procedure to be used in locating and correcting the trouble.

The output terminals of the generator consist of solder lugs mounted on the rear of the generator, to which the manual cable, pedal cable, and harp signal cable are connected. The frequency numbers of the terminals are indicated in Figure 2-3. The exact frequencies generated are shown in Table 2-1.

**2-3. MANUALS.**—Musical frequencies produced by the tone generator are routed through the manual cable terminal strips on the two manuals, and from the terminal strips to the key contact springs.

Each of the two manuals has 61 playing keys, or five octaves. Both manuals cover exactly the same pitch range.

Under each key are a number of contact springs (for the fundamental and harmonics of that key) which touch an equal number of busbars when the key is depressed. All contact springs and busbars have precious metal contact surfaces to avoid corrosion, and the manuals are sealed to exclude dust as far as possible. In case a contact becomes dirty in spite of these precautions, a busbar shifter is provided in each manual to slide the busbar endwise, thus providing a fresh contact surface.

The upper manual assembly has 12 contact springs under each key. Ten are used for the fundamental tone and nine harmonics. The additional two contacts are used for producing the Harp tone and percussion keying. The Harp effect is available on the top 4 octaves only (keys C-2 through C-6.)

The lower manual assembly has 10 contact springs under each key. Nine are used for the fundamental and eight harmonics. The remaining contact is used for keying the Brush voice.

**Table 2- 1. Generator Frequencies in R-100 Organ.**

HAMMOND FREQUENCY NO.	MUSICAL NOTE	GENERATOR Hz	HAMMOND FREQUENCY NO.	MUSICAL NOTE	GENERATOR Hz
1	C	32.72727	49	C	523.63632
2	C#	34.66667	50	C#	554.66672
3	D	36.70580	51	D	587.29408
4	D#	38.88889	52	D#	622.22224
5	E	41.20482	53	E	659.27712
6	F	43.63636	54	F	698.18176
7	F#	46.25000	55	F#	740.00000
8	G	48.97959	56	G	783.67347
9	G#	51.89189	57	G#	830.27024
10	A	55.00000	58	A	880.00000
11	A#	58.28571	59	A#	932.57136
12	B	61.71429	60	B	987.42864
13	C	65.45454	61	C	1047.27264
14	C#	69.33334	62	C#	1109.33344
15	D	73.41176	63	D	1174.58816
16	D#	77.77778	64	D#	1244.44448
17	E	82.40964	65	E	1318.55424
18	F	87.27272	66	F	1396.36250
19	F#	92.50000	67	F#	1480.00000
20	G	97.95918	68	G	1567.34688
21	G#	103.78378	69	G#	1660.54048
22	A	110.00000	70	A	1760.00000
23	A#	116.57142	71	A#	1865.14272
24	B	123.42858	72	B	1974.85728
25	C	130.90908	73	C	2094.54528
26	C#	138.66668	74	C#	2218.66688
27	D	146.82320	75	D	2349.17120
28	D#	155.55556	76	D#	2488.88896
29	E	164.81928	77	E	2637.10848
30	F	174.54544	78	F	2792.72704
31	F#	185.00000	79	F#	2960.00000
32	G	195.91836	80	G	3134.69376
33	G#	207.59276	81	G#	3321.08096
34	A	220.00000	82	A	3520.00000
35	A#	233.14284	83	A#	3730.28480
36	B	246.85716	84	B	3949.71456
37	C	261.81816	85	C	4189.09090
38	C#	277.33336	86	C#	4440.00000
39	D	293.64640	87	D	4702.04081
40	D#	311.11112	88	D#	4981.62162
41	E	329.63856	89	E	5280.00000
42	F	349.09088	90	F	5595.42857
43	F#	370.00000	91	F#	5924.57142
44	G	391.83672			
45	G#	415.13512			
46	A	440.00000			
47	A#	466.28568			
48	B	493.71432			

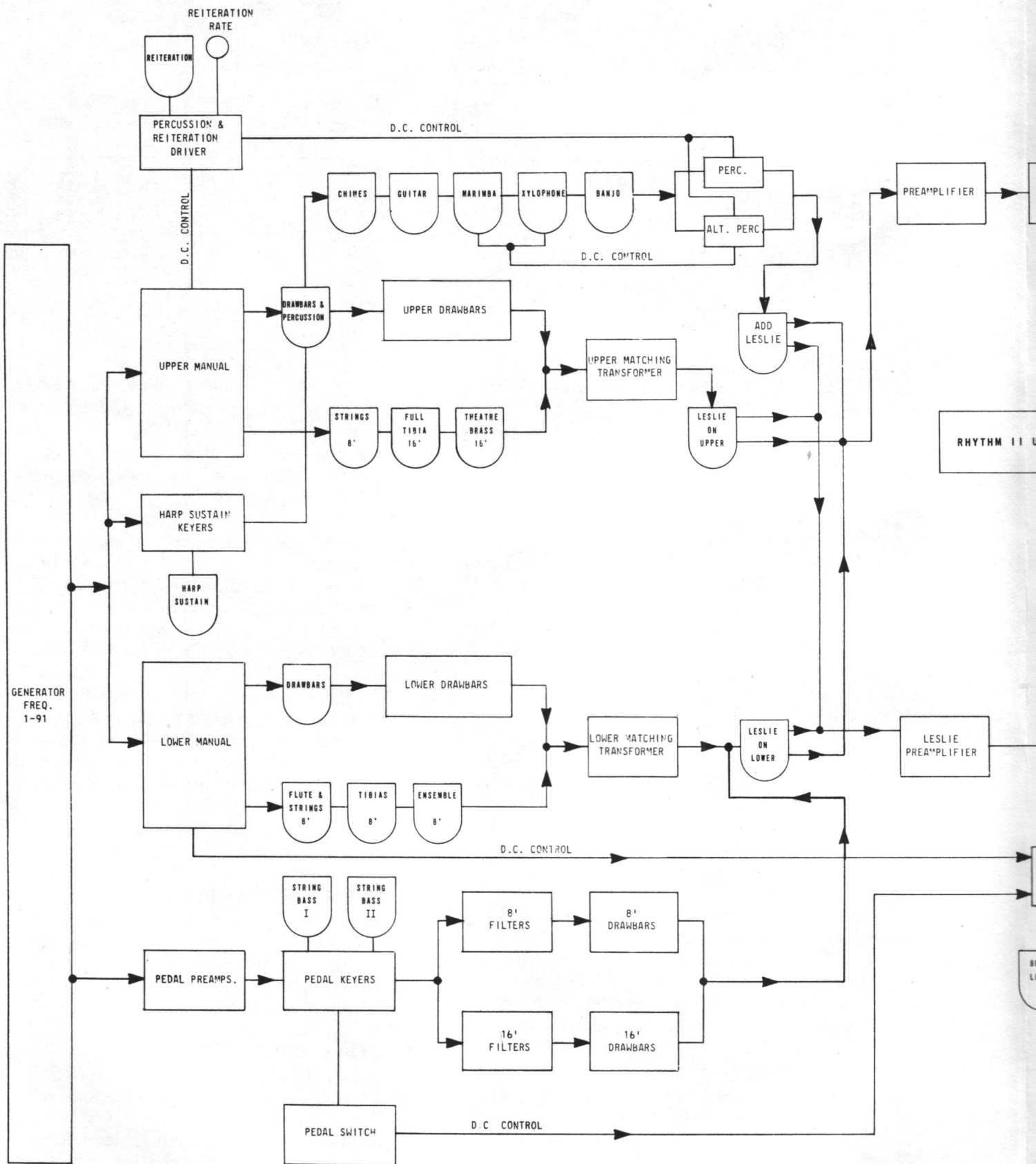

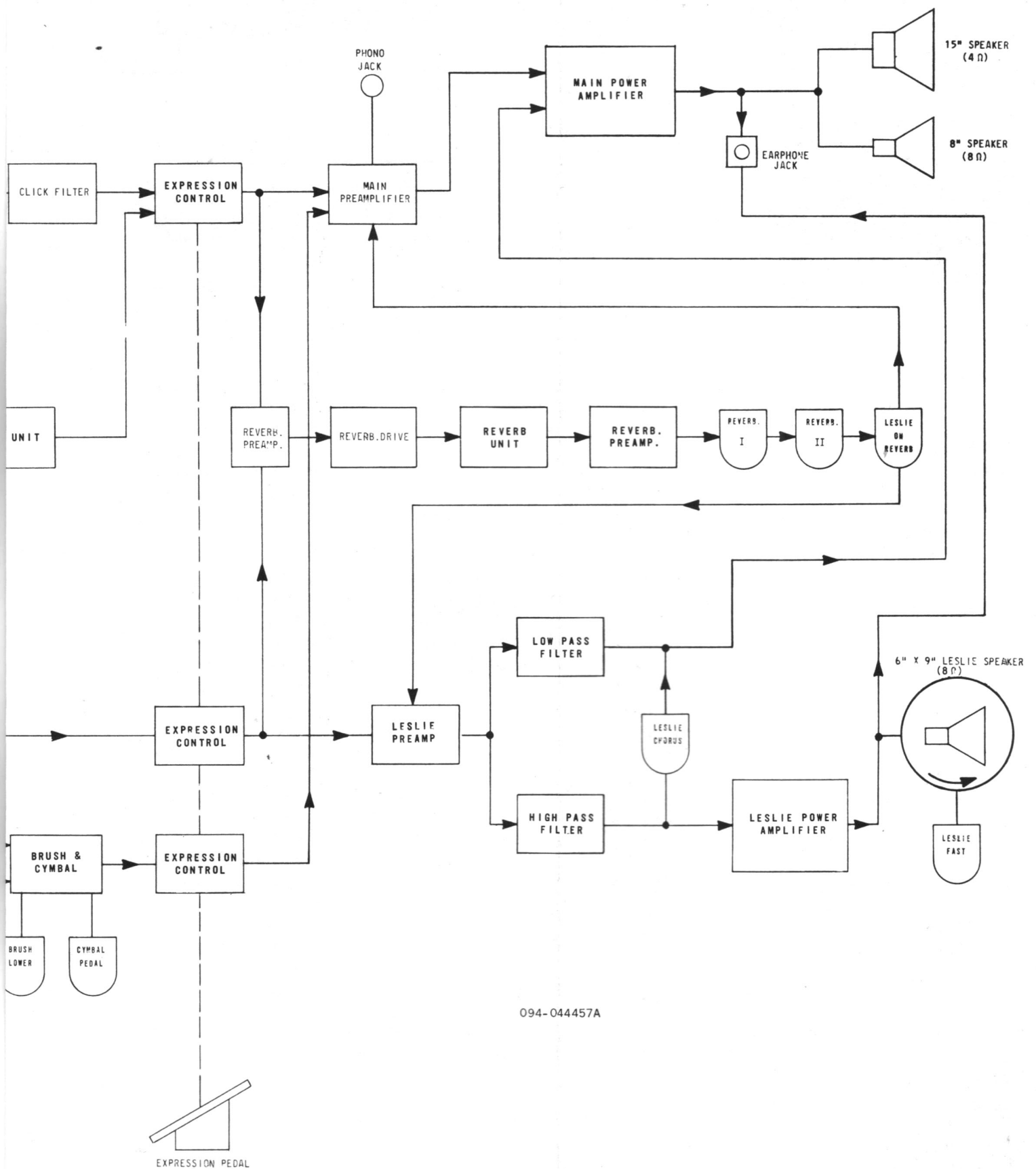

094-044457A

Figure 2-1. System Block Diagram

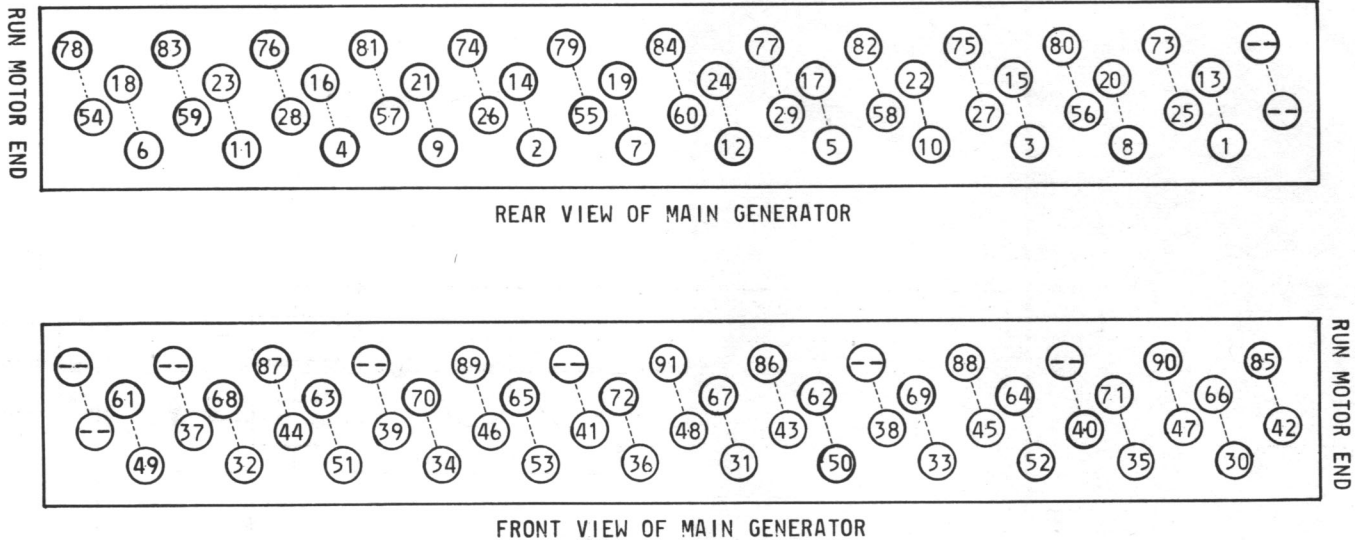

Figure 2-2. Magnet Locations on Generator

Figure 3—2 shows the location of the busbar shifters. They appear as a small metal tab with a punched hole, one for each manual. (See Figure 3—2.) They are readily accessible from the rear of the instrument, and may be moved in or out to provide a new surface for the key contacts.

The key contacts are connected through resistance wires to the manual terminal strips. The manual wiring chart, Table 2—2, indicates how the contacts of each key are connected to the frequencies which supply the fundamental and harmonics of that particular key.

The busbars of each manual, each one carrying a specific harmonic, are wired to the harmonic drawbars for the manual through the DRAWBARS tab.

**2—4. HARMONIC DRAWBARS.**—The left-hand group of nine harmonic drawbars is associated with the upper manual. The right-hand group of nine drawbars is associated with the lower manual. By sliding the drawbars in and out, the organist is able to mix the fundamental and harmonics (or overtones) in various proportions. Each drawbar is calibrated with numbers ranging from one to eight. The calibrations enable the organist to repeat any desired drawbar combination at any time by simply setting up the registration according to the numbers. The further drawbar is pulled out the stronger its harmonic will sound. If a drawbar is pushed all the way in its position may be considered as zero, and its harmonic will not be heard. From the foregoing it can be readily understood that in

order for a manual to play, its DRAWBARS tab must be depressed, and at least one of its drawbars pulled out. However, the manual will play with no drawbars pulled when one of its associated preset tabs is depressed.

The drawbars slide over 17 busbars, representing intensity levels. As the drawbar moves, its contact is touching at least one of the busbars at all times, thereby producing a smooth change in the volume of its harmonic.

The busbars for each manual terminate in the low impedance primary of a matching transformer (see Figure 5—1). Signals from the high impedance secondaries of these transformers are routed through the Leslie ON UPPER and Leslie ON LOWER switches to either the main or Leslie sections of the preamplifier (see Figure 5—4).

**2—5. PEDAL KEYBOARD.**—A standard 25-note pedal keyboard is supplied with the instrument. Like the manuals, it has black and white keys arranged in standard octave patterns. The keyboard is illustrated in Figure 2—4.

**2—6. PEDAL DRAWBARS.**—Two pedal drawbars, one 16', and one 8' are located between the two sets of manual drawbars. When the 16' drawbar is pulled, emphasis is given to frequencies 1 through 25. When the 8' drawbar is pulled emphasis is given to frequencies 13 through 37. The two pedal drawbars may be used singly or in combination.

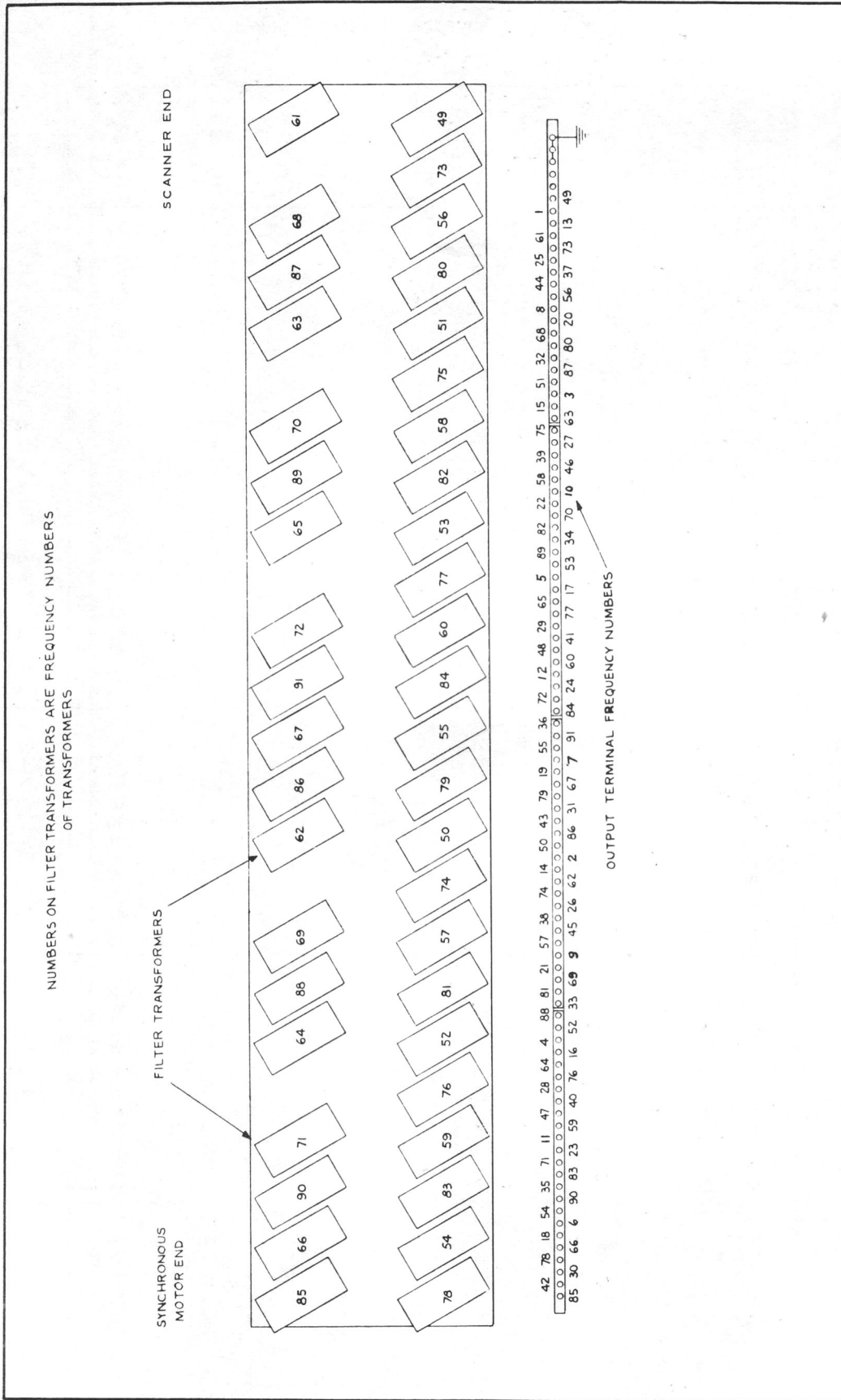

Figure 2-3. Filter Locations on Generator Cover



**Table 2-2. Frequencies used in Manuals.**

Key Number	Note	1/4 Harm. Upper Chime only	Drawbar 1 Sub-Fund.	Drawbar 2 Sub-3rd	Drawbar 3 Fund.	Drawbar 4 2nd Harm.	Drawbar 5 3rd Harm.	Drawbar 6 4th Harm.	Drawbar 7 5th Harm.	Drawbar 8 6th Harm.	Drawbar 9 8th Harm.
1	C	17	1	20	13	25	32	37	41	44	49
2	C#	18	2	21	14	26	33	38	42	45	50
3	D	19	3	22	15	27	34	39	43	46	51
4	D#	20	4	23	16	28	35	40	44	47	52
5	E	21	5	24	17	29	36	41	45	48	53
6	F	22	6	25	18	30	37	42	46	49	54
7	F#	23	7	26	19	31	38	43	47	50	55
8	G	24	8	27	20	32	39	44	48	51	56
9	G#	25	9	28	21	33	40	45	49	52	57
10	A	26	10	29	22	34	41	46	50	53	58
11	A#	27	11	30	23	35	42	47	51	54	59
12	B	28	12	31	24	36	43	48	52	55	60
13	C	29	13	32	25	37	44	49	53	56	61
14	C#	30	14	33	26	38	45	50	54	57	62
15	D	31	15	34	27	39	46	51	55	58	63
16	D#	32	16	35	28	40	47	52	56	59	64
17	E	33	17	36	29	41	48	53	57	60	65
18	F	34	18	37	30	42	49	54	58	61	66
19	F#	35	19	38	31	43	50	55	59	62	67
20	G	36	20	39	32	44	51	56	60	63	68
21	G#	37	21	40	33	45	52	57	61	64	69
22	A	38	22	41	34	46	53	58	62	65	70
23	A#	39	23	42	35	47	54	59	63	66	71
24	B	40	24	43	36	48	55	60	64	67	72
25	C	41	25	44	37	49	56	61	65	68	73
26	C#	42	26	45	38	50	57	62	66	69	74
27	D	43	27	46	39	51	58	63	67	70	75
28	D#	44	28	47	40	52	59	64	68	71	76
29	E	45	29	48	41	53	60	65	69	72	77
30	F	46	30	49	42	54	61	66	70	73	78
31	F#	47	31	50	43	55	62	67	71	74	79
32	G	48	32	51	44	56	63	68	72	75	80
33	G#	49	33	52	45	57	64	69	73	76	81
34	A	50	34	53	46	58	65	70	74	77	82
35	A#	51	35	54	47	59	66	71	75	78	83
36	B	52	36	55	48	60	67	72	76	79	84
37	C	53	37	56	49	61	68	73	77	80	85
38	C#	54	38	57	50	62	69	74	78	81	86
39	D	55	39	58	51	63	70	75	79	82	87
40	D#	56	40	59	52	64	71	76	80	83	88
41	E	57	41	60	53	65	72	77	81	84	89
42	F	58	42	61	54	66	73	78	82	85	90
43	F#	59	43	62	55	67	74	79	83	86	91
44	G	60	44	63	56	68	75	80	84	87	92
45	G#	61	45	64	57	69	76	81	85	88	93
46	A	62	46	65	58	70	77	82	86	89	94
47	A#	63	47	66	59	71	78	83	87	90	95
48	B	64	48	67	60	72	79	84	88	91	96
49	C	65	49	68	61	73	80	85	89	92	97
50	C#	66	50	69	62	74	81	86	90	93	98
51	D	67	51	70	63	75	82	87	91	94	99
52	D#	68	52	71	64	76	83	88	92	95	100
53	E	69	53	72	65	77	84	89	93	96	101
54	F	70	54	73	66	78	85	90	94	97	102
55	F#	71	55	74	67	79	86	91	95	98	103
56	G	72	56	75	68	80	87	92	96	99	104
57	G#	73	57	76	69	81	88	93	97	100	105
58	A	74	58	77	70	82	89	94	98	101	106
59	A#	75	59	78	71	83	90	95	99	102	107
60	B	76	60	79	72	84	91	96	100	103	108
61	C	77	61	80	73	85	92	97	101	104	109
		Frequency Number									

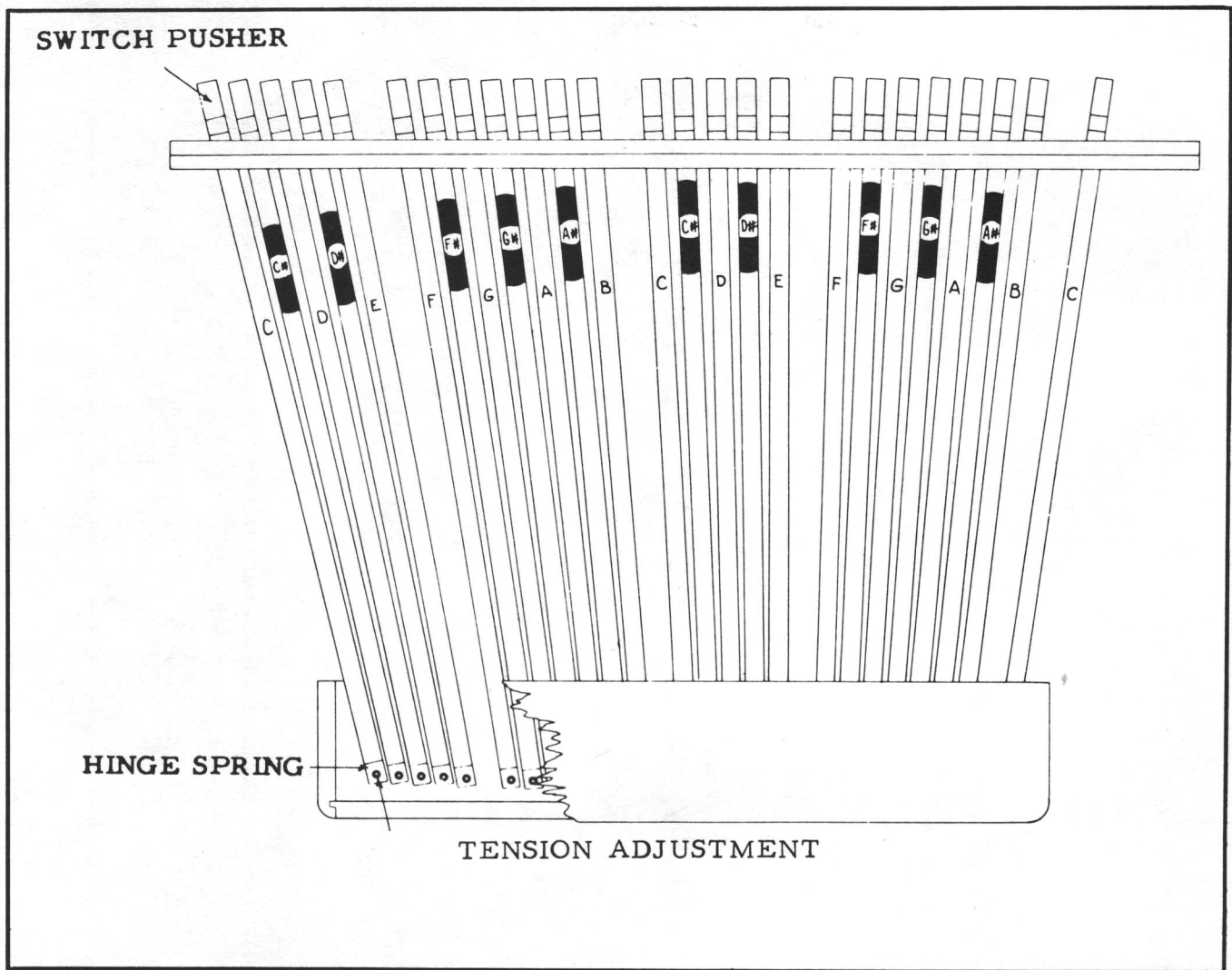

Figure 2-4. Pedal Keyboard

**2-7. PEDAL SWITCH.**—The pedal switch which is actuated by the pedal keyboard consists of 25 leaf switches, each having two sets of contacts.

As will be noted in Figure 5-3, the 37 pedal frequencies are always present at the sine wave amplifier boards. When a pedal is depressed closure of a pedal keyer which will then allow the wanted frequency to pass from the sine wave amplifier to the pedal output. The pedal sustain switches associated with the STRING BASS tabs provide increased decay time to the keyers, thereby producing the sustain or string bass effects.

The second set of contacts on the pedal keyer switches is used to key the cymbal voice when the CYMBAL PEDAL tab is depressed.

**2-8. HARP SECTION.** (See Figures 2-5 and 5-1).—There are 49 keyer circuits, one for each frequency. The signal input to the harp keyers comes directly from the tone generator (frequencies 37 through 85). These signals are applied to the emitters of the transistors Q501, while a small bias voltage, approximately 0.3v, is applied to the base of each Q501 through 10k resistors. When the HARP SUSTAIN tablet is depressed, a keying voltage is applied to the harp control busbar. When a key in the range between the second C and the top C of the upper manual is depressed, the harp control voltage is applied through R504 and R502 to the base of Q501. At the same time, this control voltage is applied to capacitor C502. The application of this voltage causes the transistor to conduct. Conduction will continue as long as the keys are depressed, and

FREQUENCIES TOP TO BOTTOM AS VIEWED

FREQ.  
81-85

FREQ.  
70-80

FREQ.  
59-69

FREQ.  
48-58

FREQ.  
37-47

C-501 Q-501 R-501 C-502

R-504  
R-502  
R-503

+22 VOLTS  
C-511  
R-517  
R-518  
R-512  
R-511  
R-514  
C-525  
R-523  
R-524  
C-522  
R-528  
R-526  
R-540  
R-541  
GROUND  
HARP  
OUTPUT  
C-513  
C-512  
R-516  
R-515  
R-513  
R-521  
C-521  
R-525  
DIRECT  
SIGNAL  
INPUT  
Q-521  
R-522  
C-523  
Q-522  
Q-527  
R-529  
HARP  
KEYING  
VOLTAGE  
C-524  
R-530  
R-531

124-000046

124-000046

124-000047

124-000047

124-000163

124-000165

Figure 2-5. Harp Keyer Assembly

will continue after the keys have been released for a time predetermined by the discharge rate of C502. The value of C502 is 15 uf on frequencies 37 through 58; 8 uf on remaining frequencies. The signals from the collectors of Q501 are then routed through Q521 and Q522.

In addition to the above, the following also takes place: when the HARP SUSTAIN tablet is depressed, the second harmonic busbar signal is connected through a primary winding on T804. The result is that any time a key is depressed, a signal is generated in the secondary of T804. This second harmonic signal (same pitch as harp signal) is introduced at the emitter of Q521. The purpose of this signal is to enhance the harp effect by providing an instantaneous signal in the harp channel.

Output of Q522 is routed through the Drawbars and Percussion switch to the ADD LESLIE tab. Depending upon the position of the ON UPPER MANUAL tab the harp will sound either through the main channel alone or through both main and Leslie channels.

## **2-9. CYMBAL AND BRUSH GENERATOR BOARD, 124-000020 (see Figure 5-5).**

—The cymbal and brush generator is basically a "white noise" generator feeding two gating transistors, the outputs of which are shaped and fed to a common transistor amplifier.

Transistor Q904 serves as the noise source. The noise is amplified by Q905, and regulated by R922.

It is to be noted that R922 is set at the factory and will generally require no adjustment. No data for adjusting R922 are contained in Table 4-1.

**CYMBAL/PEDAL.** —With the CYMBAL PEDAL tablet depressed, and a pedal depressed, a keying voltage (approximately 6V) is applied to one plate of C909. C909 differentiates the change to produce a positive pulse. The pulse forward biases D905, charging C910 and applying the keying voltage to the base of Q906. This voltage causes Q906 to conduct, amplifying the white noise from R922. The noise is coupled to the base of Q906 through C904.

The collector circuit of Q906 is a broadly tuned resonant circuit of approximately 8kHz. The output of this circuit is fed to the amplifying transistor Q903 and from Q903 to the expression control. R917, a variable resistor in the collector circuit of Q902 controls the cymbal output level.

The decay time of the cymbal effect is governed by C910 and R914, while the sustained level is controlled by R911 and R913 as long as a pedal is depressed. The cymbal effect will be heard each time a pedal is depressed. D904 grounds the negative-going spike produced by release of a pedal.

**BRUSH/LOWER.**—With the BRUSH/LOWER tab depressed, and a lower manual key depressed, a small negative variation in DC voltage occurs at the base of Q901. This small variation is amplified by Q901 and appears as a larger varying potential on one plate of C901. D901 differentiates the change to produce a positive pulse. The pulse forward biases D902, charging C902 and applying the voltage to the base of Q902. This voltage causes Q902 to conduct, amplifying the white noise from R922. The noise is coupled to the base of Q902. The collector circuit of Q902 is a broadly tuned resonant circuit of approximately 11kHz. The output of this circuit is routed to the amplifying transistor Q903 and thence to the expression control. The decay time of the brush effect is governed by the values of C902 and R903. R907, a variable resistor in the collector circuit of Q902 controls the brush output level. D901 grounds the negative-going spike produced by release of a key.

## **2-10. PERCUSSION AND REITERATION DRIVER 128-000001 (See Figure 5-7).**

—This unit operates in two-modes Percussive and Reiterative. Percussive can be "Touch Control" or LEGATO. Reiteration is controlled by REITERATION tab.

In the percussive mode in standby condition, transistors Q201, Q204, and Q205 are not conducting, hence their collectors are at +25 volts for the three transistors. The +25V potential is a reverse bias for D204, which is therefore not conducting. Condenser C203 is charged to +10.5V via

any one of the charge time determinant resistors "R".

When a key is depressed, the keyer contact applies +6V to terminal 3. The current which charges C201, passes through R203 and produces a positive pulse at the base of transistor Q201. Transistor Q201 saturates and its collector voltage drops momentarily below one volt. The resulting negative pulse at the collector of Q201 discharges condenser C202. The discharge current of C202 passes through resistor R207 and effects a positive pulse at the base of transistor Q204.

Diode D202 eliminates a negative pulse at the base of Q204, which would have resulted from releasing the key.

The positive pulse saturates Q204 and this in turn saturates Q205. The collector voltage of Q205 drops below one volt and D204 is at forward bias potential. Condenser C203 discharges momentarily via diode D204, transistor Q205, and resistor R209.

This condition is the starting point of percussion drive ramp signal.

After completion of the discharge pulse, C203 charges again via one of the charge time determinant resistors.

The dual emitter follower stage, consisting of transistor Q206 and Q207, isolates output terminal 9 from the timing condenser C203.

In the reiterative mode, in standby condition, condenser C203 is charged to approximately +10.5V via resistors R211 and R212.

When a key is depressed, the keyer contact applies +6 volts to terminal 5. A forward bias is thereby placed on transistors Q202 and Q203. Q203 saturates and connects diode D205 to ground. Diode D205 "fires" and condenser C203 discharges through transistor Q203. C203 charges again through R211 and R212. The charge speed is adjusted by Reiteration Rate Control R211.

When C203 is charged to the "firing"

voltage of D205, another discharge follows. This cycling continues as long as a keyer contact is closed. The reiterative pulse is connected through isolation transistors Q206 and Q207 to terminal 9.

**2-11. PERCUSSION GATE AMPLIFIER 117-000001 (See Figure 5-8).**—A positive DC voltage from R112 is applied through R111 to the gate terminal of F.E.T. Q102. This voltage is adjusted by means of R112 to the pinch-off voltage of the Q102 F.E.T. Under this condition the drain to source resistance of Q102 is very high (tens of megohms) and Q102 does not influence the operation of Q101.

An audio signal from transformer T101 is fed via C101 to the base of transistor Q101. Because of unequal emitter and collector loads (R104 and R105), the signal across R105 is much greater than across R104. The signal across R105 is in phase with the signal at the base of Q101 and the signal across R104 is 180° shifted in phase. The signals from the collector and emitter of Q101 are mixed via R107 plus R109, and via R108 plus R110 in such a way that they both appear at point 7 in equal level and out of phase. The result is that both signals cancel each other and there is no output from the gate. This is the condition when the gate is closed.

When the DC voltage from the F.E.T. gate Q102 is removed, the drain to source resistance becomes very small (a few hundred ohms) and this virtually places C104 in parallel with R105. The result is that the signal at the collector of Q101 increases, because C104 decouples the signal current degeneration in R105. This, in turn unbalances the signal null point at point 7 and the gate has maximum output, or is "open".

A variable DC voltage impressed upon the gate Q102 will cause a variable signal output from the gate.

Transistors Q103 and Q104 perform as a conventional amplifier to raise the output from the gate to the proper level. R113 adjusts the gain of the amplifier as required.

**2-12. ALTERNATE PERCUSSION GATE AMPLIFIER 117-000002 (See Figure 5-9).**—This amplifier consists of two parts. The oper-

ation of the circuit consisting of transistors Q301, Q302, Q303, and Q304 is identical to 117-000001. The other portion, alternate repeat driver, consisting of transistors Q306, Q307, Q308, Q309 and Q310, performs as follows.

With no input, transistor Q306 is at cut-off and the voltage at the collector is near the supply voltage. This positive voltage is coupled to the base of transistor Q307 through resistor R325.

Current flow from transistor Q307 through common emitter resistor R327 maintains the emitter of transistor Q306 at positive potential. The reverse bias now developed between emitter and base of transistor Q306 maintains the cut-off condition.

The high positive voltage at the base of transistor Q307 causes it to operate in the saturated region.

A positive voltage applied to the base of Q306 will overcome the reverse bias and cause Q306 to conduct. The potential at the collector decreases and is coupled to the base of Q307.

The emitter current of Q307 decreases, lowering the potential across R327. The emitter Q306 becomes less positive, reducing the reverse bias and increasing the collector current. This continues until Q306 is operating in the saturated region and transistor Q307 is cut-off. Varying the input voltage from positive value to zero will cause transistors Q306 and Q307 to alternately turn on and off and produce a square wave output at the collector of Q307.

Transistors Q308 and Q309 are not conducting until a positive voltage appears at the base of Q308. The square wave is differentiated across capacitor C310 and appears as a positive pulse at the base of Q308. D301 eliminates the negative part. Capacitor C311 of the differentiated wave shape is charged to the zener voltage D303 (normally +11V). When transistor Q308 and Q309 are conducting, capacitor C311 will discharge. Capacitor C311 will charge again via the reiteration control at a rate determined by the setting of that control.\*

The discharging and charging of capacitor C311 causes transistor Q310 to conduct, or

not to conduct, producing a pulse which is delayed compared to the input pulse appearing at Q306. The time of delay is controlled by the DC level set by control R323.

\*D302 provides isolation between the charging circuit (located in the Percussion and Reiteration Drive Assembly) and alternate charging circuit, composed of R330 and R332.

**2-13. PREAMPLIFIER BOARD, 124-000161 (See Figure 5-4).**—The preamplifier board circuitry consists chiefly of two amplifier circuits, one for the main channel and one for the Leslie channel. Each of these channels is separated into two sections, one of which is a three stage amplifier, and the other of which is a two stage amplifier. In each case the control section of the swell pedal assembly (paragraph 2-18) is in series between the two sections.

The first section of the main channel preamplifier consists of Q401, Q402, and Q403. The signal from the main channel is coupled through an impedance matching network consisting of R401, C401, and R402, then through C402 to the base of Q401, a common emitter amplifier. The output at the collector of Q401 is directly coupled to the base of Q402. R409 and R403 in the emitter circuit of Q402 serve to establish a bias voltage for Q401; also as a path for degenerative feedback to stabilize the circuit.

Between the collector of Q402 and the emitter of Q401 is another feedback circuit consisting of C404, C403, R407, and R406. R407 can be regulated to provide a proper balance between the high and low tones.

The output from the collector of Q402 is routed through a click filter network and then through C412 to the base of Q403, an emitter follower. Bias for Q403 is developed through R417. The output at the emitter of Q403 is coupled through C413 to the swell pedal, whose action is explained in paragraph 2-18.

After passing through the swell pedal circuitry, the signal re-enters the preamplifier board at pin 7, and is coupled through C414 to the base of Q404, a common emitter amplifier. Output at the collector of Q404

is directly coupled to the base of Q405, an emitter follower. The output at the emitter of Q405 is coupled through C415 to the main amplifier. R427 in series with the emitter of Q405 and C415 is used to regulate the gain of the final stage. The output of Q405 is also connected to the reverberation drive, which consists of Q411 and its associated circuitry.

Note that signals from the Rhythm II circuit are introduced into the main channel amplifier at the junction of R414 and C412. The signals are coupled through Q403 to the swell pedal.

When the Leslie cancel switch on the swell pedal is depressed, signals from the first three stages of the Leslie preamplifier are combined through R422 into C414, so that both channels will be combined in the main output.

Signals which enter the Leslie channel are selected by means of switches associated with the LESLIE ON UPPER, LESLIE ON LOWER, and LESLIE CHORUS tabs.

Signals selected for the Leslie channel are coupled from pin 21 through an impedance matching network and C417 to the base of Q406. The circuitry of Q406 and Q407 is identical to the circuitry of Q401 and Q402 described previously. The signal from the collector of Q407 is directly coupled to the base of Q408, an emitter follower.

The emitter signal from Q408 is coupled through C421 to the Leslie channel of the swell pedal circuitry. See paragraph 2—18. From the swell pedal the Leslie channel signals are coupled through C422 through the amplifier circuitry comprised of Q409 and Q410. This circuit is identical to Q404 and Q405 described previously. From the emitter of Q410 the signal is coupled through C423 to the main amplifier. R447 in series between the emitter of Q410 and C423 is used to adjust the gain of the final stage.

The output at the emitter of Q410 is also coupled through C425 to the base of Q411.

**2—14. ACTIVE FILTERS BOARD, 124-000135 (See Figure 5—6).**—The active filters board employs the technique of using active elements, in this case transistors, in a filtering system, in place of the usual L-C networks.

The input to the board from the power amplifier is at pin 5. The two filter networks separate the high frequency tones from the low frequency tones, so that the high frequencies may be routed to the Leslie speaker. The cross-over point between the two networks is at approximately 100 Hz. Resistors R1 and R8 serve to isolate the two channels from each other.

In the high frequency channel the response is governed by the values of C1, C2 and R2, with the input at the base of Q1, a common emitter amplifier. Q2 provides degenerative feedback for Q1 to stabilize the gain, and provides sharp rolloff of the low end of the pass band. The output is coupled through C3 and R7 and returned to the power amplifier at pin 45 of the power amplifier board.

In the low frequency section the response is governed by the values of R11, R12, C5 and C6. The input is coupled to the base of Q3, a common emitter amplifier. Q4 provides degenerative feedback to stabilize the gain of Q3, and provides sharp rolloff of the high end of the pass band. The output is coupled through C7 and R15 to pin 6 of the board, which is in turn connected to pin 43 of the power amplifier board.

In the active filters board pin 4 is connected to pin 8 when the LESLIE CHORUS tab is depressed. The output of the high frequency channel is thereby coupled through C9 to the base of Q5, a common emitter amplifier, which has a gain factor of approximately 3. The output at the collector of Q5 is coupled through C8 and combined with the output of the low frequency channel at pin 6. The result is that the high frequency will be heard in both channels.

Pin 7 serves as an input point for external sound sources such as a phonograph or cassette recorder, with R16 providing the necessary input isolation.

**2—15. SINE WAVE AMPLIFIER BOARDS, 124-000139 (Board No. 1) and 124-000154 (Board No. 2).**—There is a total of 37 individual transistorized, encapsulated amplifiers, one for each pedal frequency. The amplifiers are identical. Eighteen are mounted on Board No. 1; 19 on Board No. 2. See Figure 5—3.

Each encapsulated network (See Figure

5-3) is an RC-coupled common emitter amplifier, with B supply at +20V at pin 3. DC bias is obtained by means of a voltage-feedback circuit. Base-to-emitter voltage is approximately 600 mv.

Input to the amplifiers is from the tone wheel generator. Output from the amplifiers is to the Pedal Keyer boards.

Each network receives its input through a Tantalum capacitor, designated as C601, Figure 5-3. Values of coupling capacitors range from 2.2 uf to 6.8 uf, depending on frequency.

A typical circuit for one pedal is shown in Figure 2-6.

**2-16. PEDAL KEYER BOARDS, 124-000138 (Board No. 1) and 124-000153 (Board No. 2).**—

Each Pedal Keyer board carries encapsulated 8' and 16' keyer circuit pairs. Board No. 1 carries 12 pairs; Board No. 2 carries 13 pairs. Each of the keyer circuits is a passive network comprised of resistors, capacitors and diodes. See Figure 5-3.

Generator frequencies are always present at pin 1 of each network. The signals are blocked by the series diodes until keying voltage is applied at pin 9 of the 16' keyer. Signal blocking is achieved because the series diodes offer a high resistance path for the signal. If the signal amplitude is great enough, the diode connected to pin 1 will conduct on the negative portion of

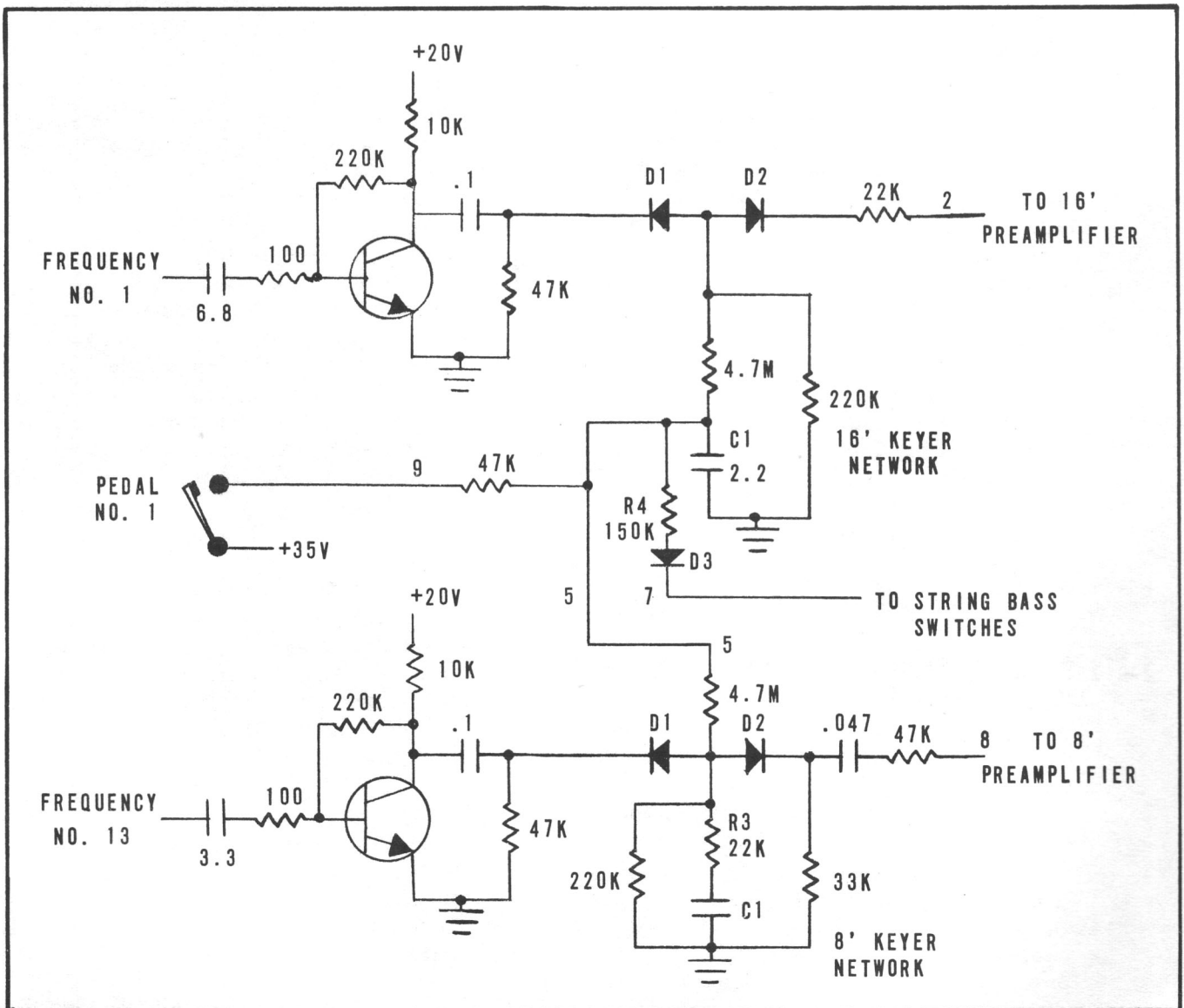

Figure 2-6. Typical Pedal Circuit



the sine wave, with a resultant negative voltage at the junction of the two diodes. The negative voltage reverse biases the second diode, so that the signal is effectively blocked.

When a pedal is depressed, +35V is applied to pin 9 of the 16' keyer. The 2.2 uf capacitor charges to approximately +26V in about 30 ms. The charge on the capacitor places positive (+) voltage at the junction of the series diodes (approximately 0.5V above ground). With positive voltage at the junction, both series diodes will conduct, permitting the signal to pass.

The keyers are keyed "on" in pairs, since pins 5 of the encapsulated networks have a common connection. Signal is present at the outputs (pin 2 of 16' and pin 8 of 8') as long as the pedal is depressed. When the pedal is released, the 2.2 uf capacitor discharges. The main discharge path is through the 150K resistor and the diode D3 with pin 7 of the 16' network grounded (non-sustain). The discharge time is about 125 ms. Longer sustain times are provided by the action of the STRING BASS tab switches, which, when "on," insert series resistors into the discharge path to increase the time constant. See Figure 5-1.

Diode D3 in each 16' keyer serves to prevent unwanted keying by isolating the inactivated keyers, since all pins 7 have a common connection.

The 8' keyers differ from the 16' keyers in that they contain wave shaping elements and output coupling capacitors. The wave shaping elements are R3 and C1, Figure 5-3.

#### **2-17. PEDAL PREAMPLIFIER BOARD, 124-000137 (See Figure 5-3).**

— The pedal preamplifier board consists essentially of two separate two-stage amplifiers, one for the 16' tones, the other for the 8' tones. Each stage is of the common emitter type, with bias developed through a voltage dropping resistor.

The amplifier for the 16' tones consists of Q601 and Q602. The output of Q601 is coupled to the base of Q602 through a low pass filter network consisting of R604, R605, C653, R606, and C654. The output of Q602 at the collector is coupled through C655 and R610 to the 16' pedal drawbar.

The amplifier section for the 8' tones consists of Q603 and Q604. Between the two stages is a pass filter comprised of C657, C658, C659, and R614. Following the pass filter is the 8' gain adjust potentiometer R615 through which the signal passes before being coupled to Q604. The output at the collector of Q604 is coupled through C661 and R618 to the 8' drawbar.

Note that there is no gain adjustment in the 16' amplifier section. The gain of the 8' section is adjusted to balance with the gain of the 16' section.

#### **2-18. SWELL PEDAL ASSEMBLY, 123-000046 (See Figure 5-14).**

— The swell pedal assembly controls the output volume of the organ by means of photo-conductive cells which are acted upon by a light bulb. Between the light bulb and the photoconductive cells is a shutter which moves with the swell pedal. As the pedal is moved forward, that is toward maximum volume position, the shutter allows more light to reach the cells, causing them to conduct more of the signal (decreased resistance).

While the actual configuration of the swell pedal circuitry is such that four channels could be used, only three of the available channels are used in the R-100 instrument. Each channel has a compensating network in parallel with its photoconductive cell and each complete network is in series between stages of the preamplifier. See Figure 5-14. The compensating networks are mounted on a printed wiring board, No. 124-000126.

Two control switches form an integral part of the swell pedal assembly. On the right is a foot-operated switch which, when actuated, connects the first stages of the Leslie preamplifier to the final stages of the main channel amplifier, thereby removing sound from the Leslie and combining both channels in the main output.

On the left of the swell pedal is a foot-operated switch which, when actuated, shunts the output of the automatic rhythm unit to ground, thereby silencing the rhythm output as long as the switch is held in the closed position.

#### **2-19. POWER AMPLIFIER, 124-000162 (See Figure 5-11).**

— The power amplifier is a two-channel amplifier, one channel for main

output, the other channel for Leslie output. Each channel consists essentially of a pre-amplifier section, a drive amplifier section, and an output section.

The Leslie channel input is at pin 13, where the signal is coupled through C13 to the base of Q6, a common emitter amplifier. Bias for Q6 is provided through R35. The signal from the collector of Q6 is coupled through C15 to the base of common emitter amplifier Q7, and from the collector of Q7 directly to the base of Q8, an emitter follower.

From the emitter of Q8 the signal is routed through the input of the active filter board from pin 44 of the power amplifier to pin 5 of the active filter. The high frequencies are returned from the active filter, pin 3 to pin 45 of the power amplifier. The low frequencies return from pin 6 of the active filter to pin 43 of the power amplifier. As will be noted in Figure 5-11, only the high frequencies enter the final amplifier section of the Leslie channel but the high frequencies may be combined with the low frequencies when the LESLIE CHORUS TAB is depressed. See paragraph 2-14 (Active Filters).

The filtered high frequency is coupled to the first stage of the drive amplifier, Q9, through C20. Bias for this stage is provided through R52, while degenerative feedback to stabilize the circuit is provided from the output transistors to the emitter of Q9. The network consisting of R55, R56, and C23 increases the gain of the stage. The output from the collector of Q9 is directly coupled to the base of Q10, the first of a Darlington pair. The output of the Darlington pair at the emitter of Q11 is coupled through C24 to the primary of push-pull transformer T704. Final output is obtained through the secondaries of T704, one of which is coupled to the base of Q705; the other is coupled to the base of Q706.

Note that in the preamplifier stage of this channel the reverberated signal is introduced at pin 11 and is coupled to the base of Q7 through C16. Q6 is not used as an amplifier for the reverberated signals. The reverberated signals are present only when the LESLIE ON REVERB tab is depressed (See Figure 2-1).

Input to the main channel preamplifier section is at pin 1. The signal is coupled to the base of Q1, a common emitter amplifier, through C2. Bias for Q1 is provided through R2. Output from the collector of Q1 is coupled through C4 through the base of Q2, which is also a common emitter amplifier. The low frequencies from the active filter (See paragraph 2-14) are mixed with the output at the collector of Q2, whenever the Leslie channel is in use, and the combined signal is coupled through C7 to the base of the first stage, Q3, of the drive amplifier. Feedback to stabilize the circuit is taken from the outputs of Q1 and Q2, and coupled to the emitter of Q3. The RC network consisting of R20, R21 and C10 provides additional gain to the stage.

The output at the collector of Q3 is coupled to the base of Q4, the first stage of a modified Darlington pair. Note R70 between the emitter of Q4 and the base of Q5. The output at the emitter of Q5 is coupled through C11 to the primary of push-pull transformer T703. Final output is obtained through the secondaries of T703, one of which is coupled to the base of Q703; the other is coupled to the base of Q704.

Note that the main channel reverberated signal entering at pin 5, is coupled to the base of Q2 through C5, while the Brush and Cymbal signals from pin 3 are coupled to the base of Q2 through C6. Q1 is not used in the amplification of these signals.

Note, also, that connections at pins 43, 44, and 45 are in the circuit only when the Leslie channel is in use.

## 2-20. REVERBERATION AMPLIFIER 117-000003 (See Figure 5-10).

— The signal is fed to the base of transistor Q251 and amplified. It is then directly coupled to an emitter follower Q252 and capacity coupled through C252 to drive transformer T251. The secondary winding of T251 is to push-pull transistors Q254 and Q255, and capacity coupled through C254 to the reverberation drive coil. One side of the reverberation drive coil is connected to R254 and R264. The signal is fed back (current feedback) to Q251. After the signal has been delayed through the spring unit, it is fed to the base of transistor Q257 where it is amplified

and directly coupled to emitter follower and then capacity coupled through C259 to reverberation level control R273.

As the reverberation unit is always in operation, it will require that one or both of REVERB I & REVERB II tabs be depressed for the effect to be added.

## **2-21. POWER SUPPLY, PART OF 126-000066**

(See Figure 5-13).—Three separate circuits are mounted on the power supply chassis; the Leslie speaker relay, the music panel transformer, and the power supply itself. The Leslie speaker relay operates on -26 volts from the bridge circuit consisting of D701 through D704. D713 across the primary of the relay serves to suppress spikes when the relay is actuated. When the relay is actuated the secondary contacts switch primary power to the fast Leslie motor. When the relay is not actuated, primary power is supplied to the slow Leslie motor.

T702, the step-down transformer with a single secondary, provides 14 VAC for the music panel lights.

The power supply circuitry receives primary power through T701, which has four secondaries. The first of these is used to provide 5.4 VAC to the pilot lamp and swell pedal exciter lamps. The second winding, which is center tapped, and filtered by C701A, is rectified by a full-wave bridge circuit consisting of D701 through D704 to provide unregulated +26 volt and -26 volt power. Filtering is provided by C702 and C703.

The third secondary which is not center tapped, and is filtered by C701, is rectified by a full-wave bridge consisting of D705 through D708. The output of the bridge is filtered by C704 and then is fed through a regulator circuit consisting of series regulator Q701 and associated circuitry. Diodes D709 and D710 serve to provide overload protection to the regulator circuit. Q702 serves as a differential amplifier to regulate the bias on Q701, thereby stabilizing the final output voltage.

Zener diode D711 provides a reference voltage for the emitter of Q702. R704 on the base of Q702 serves to compensate for tolerance differences in the various resistors of the circuit. It is factory adjusted to bring the output to exactly 25 volts, and should require no adjustment in the field.

C706 provides final filtering for the +25 volt output. The +25 volts is dropped through R709 to +15 volts. The 15-volt output is filtered by C707 and is used by the power amplifier board. The 25-volt source is also dropped through a divider consisting of R707 and R708 to provide +6 volts which is used as keying voltage for the Brush and Cymbal voices.

The fourth secondary of T701 provides +35 volts, unregulated, to the pedal switches. The voltage is half-wave rectified by D712, and filtered by the pi network consisting of C708, R710, and C709. R711 serves as a bleeder resistor.

## SECTION III DISASSEMBLY

**3-1. GENERAL.**—This section contains disassembly instructions for the R-100 organ. Removal of parts is described in disassembly sequence. Removal techniques which are obvious are not discussed. Where replacement of an assembly is required, disconnect associated wiring before beginning removal operations. In all cases, reassembly is accomplished by reversing the disassembly procedure.

**3-2. REMOVAL OF ORGAN TOP ASSEMBLY.**—The organ top is to be removed with the Rhythm II chassis and the music light assembly attached. Prepare for removal by disconnecting P802 at the rear of the Rhythm II housing, and P801, the music light connector (see Figure 4-7). To loosen the top, unscrew two screws from the underside of the rear top rail. Lift the top assembly at the front. It is held in place by two friction catches, one in each of the decorative wooden blocks above the tab groups at the left and right of the organ. As soon as the catches are released, the top can be lifted clear of the organ.

**3-3 REMOVAL OF DECORATIVE WOODEN BLOCKS.**—The decorative wooden blocks must be removed for access to the tab switches underneath. The blocks themselves are held to the control panel by one friction catch at the front of each. Lift the block at the front. Be careful not to bend locating pins in each end of the block.

**3-4. REMOVAL OF CONTROL ASSEMBLY.**—The control assembly may be removed entirely, or in three sections; left, right, and center.

### CAUTION

When removing manuals, control assembly, or any of its parts, protect wooden cheeks with cardboard or other suitable material to prevent scratching. Also, protect painted parts, as directed in the following, to prevent scratching.

To remove the entire control assembly, proceed according to the following:

- a. Remove three round head screws from top of stop switch base; two at right end (front view), one at left.
- b. For access to the fourth round head screw, pull knobs from Reiteration control assembly; then loosen Reiteration control assembly by removing the hexagon nut which fastens the potentiometer assembly to the panel. Swing Reiteration Control assembly aside, then remove fourth screw.
- c. Disconnect plug P200 on Reiteration control assembly (See Figure 4-7), and lift out control assembly.

To remove right hand (front view) control section, proceed according to the following:

- a. Remove four slotted hexagon head screws from bottom of section.
- b. Lift section slightly and insert protective cardboard or other suitable substance between section and stop switch base.
- c. Remove two slotted hexagon head screws which fasten section to center section.
- d. Before lifting right hand section:
  1. Insert protective sheet between sections.
  2. Disconnect or remove power switch and pilot lamp.

Removal of left hand control section is accomplished in a manner similar to the right hand section. Observe all protective procedures. Disconnect P200 as directed above.

To remove center control section, proceed according to the following:

- a. Loosen, but do not remove, four screws which fasten right hand section. Protect stop switch base and organ cheek.
- b. Remove two screws at each end which fasten center section to end sections. Place protective material between sections. Lift out center section.

**3-5. REMOVAL OF UPPER MANUAL.**—To remove upper manual, first remove screws from lower manual cover (at front of organ) and allow cover to hang by the phone jack wires. Loosen one cable clamp to provide sufficient slack. Then proceed according to the following:

- a. Remove large 1/4-20 hexagon head screw from underneath manual at right end (Figure 3-1).
- b. Remove two 1/4-20 hexagon head screws from underneath manual at left end (Figure 3-2).
- c. Remove 1/4-20 hexagon head screws from ends of upper manual support brackets at rear (Figure 4-7).
- d. If complete removal of manual is not required, support manual on wooden blocks for access to required parts.

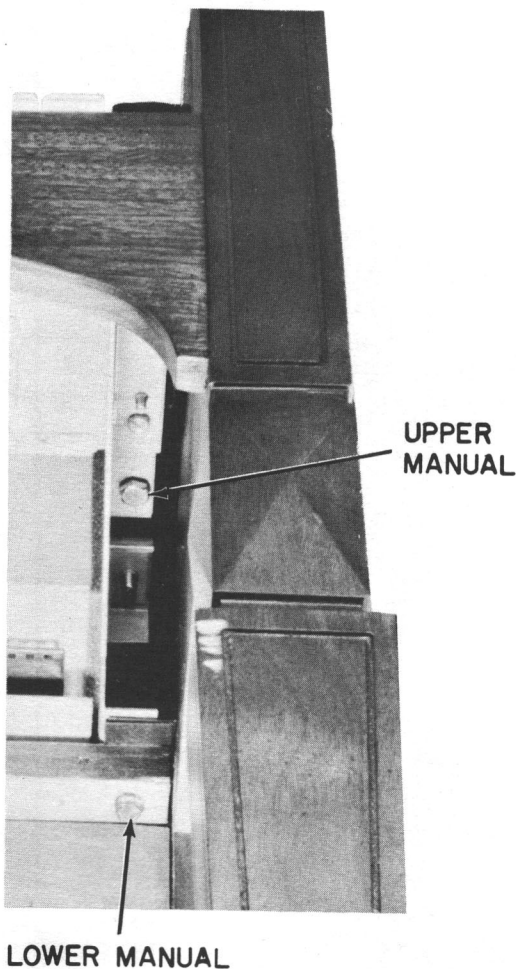

Figure 3-1. Location of Upper Manual Attaching Screw, Right Front

**3-6. REMOVAL OF LOWER MANUAL.**—To remove the lower manual:

- a. Remove three 1/4-20 hexagon head screws, one at right end and two at

left end, from underside of shelf in front of baffle. See Figures 3-1 and 3-2.

- b. Remove two similar screws from underside of shelf behind baffle.
- c. Loosen (do not remove) five hexagon head screws on rear of organ front rail. Lift manual.

**3-7. REMOVAL OF PEDAL SWITCH ASSEMBLY.**

—To remove the pedal switch assembly, first remove the pedal clavier. Next, at rear of organ, open cable ties to provide slack in pedal switch cabling. Then remove two hexagon head screws, one at each end, from the vertical surface of the angle-iron switch rail. Pull switch assembly forward until clear of organ.

**3-8. REMOVAL OF LESLIE UNIT.**—To remove the Leslie unit, disconnect P703 (See Figure 4-6), then remove two screws at top of unit, and one at bottom, which secure the unit in place. Grasp unit at top, and slide toward rear of organ on its tracks until it is clear of console. Note that the track at left (rear view) is dadoed into the organ cheek, while the other track is formed metal.

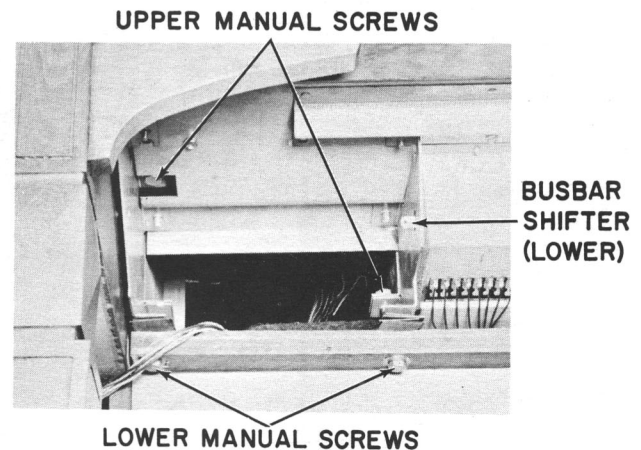

Figure 3-2. Location of Upper Manual Attaching Screws, Left Front

**3-9. REMOVAL OF LESLIE TWO-SPEED MOTOR.**

—To remove the motor assembly from the Leslie unit, proceed according to the following:

- a. Push six-pin connector plug through hole in side of wooden Leslie housing.
- b. Disconnect contact from bottom of Mercotac. Remove staple which holds red and black signal wires.
- c. Remove drive belt from motor pulley.

- d. Remove two wing nuts, lock washers, and flat washers which secure motor assembly in place.
- e. Lift motor assembly off angle bracket on which it hangs. Entire motor assembly can now be moved clear of unit.

### 3-10. SMALL MOTOR DISASSEMBLY.

- a. After removing two-speed motor assembly from the cabinet, detach the small motor and its mounting bracket from the "U" brackets by unscrewing the four mounting bracket screws.
- b. Remove the nuts and washers attaching small motor to its mounting bracket. (See Figure 3-3.) Remove lower adjustment nut from the small motor adjustment screw. (See Figure 3-3.)
- c. Separate small motor from its mounting bracket. Small motor is now ready for cleaning and lubrication.

### 3-11. LARGE MOTOR DISASSEMBLY.

- a. Remove rim drive pulley assembly from the "U" bracket end of the large motor shaft using a 3/32 Allen wrench to loosen the pulley set screw. (See Figure 3-3.)
- b. Mark "U" bracket and corresponding point on the end bell of the large motor before performing step c. This permits correct realignment of the "U" bracket and the large motor during reassembly.
- c. Remove the three screws attaching "U" bracket to the motor and detach it. Large motor is now ready for cleaning and lubrication.

### 3-12. REASSEMBLY OF LARGE AND SMALL MOTOR.—

- a. Reverse disassembly procedures for each motor, observing the following:
  1. Replace the neoprene "O" ring of the rim drive pulley if it is excessively worn. If rough spots exist on the "O" ring, twist it until the outer edge is smooth.
  2. When installing rim drive pulley on the large motor shaft, put it on as far as it will go; then back it off 1/16th inch.
  3. Be sure to align rim drive pulley set screw with the FLAT side of the large motor shaft; then tighten pulley in place.
- b. After reassembly is completed, clean

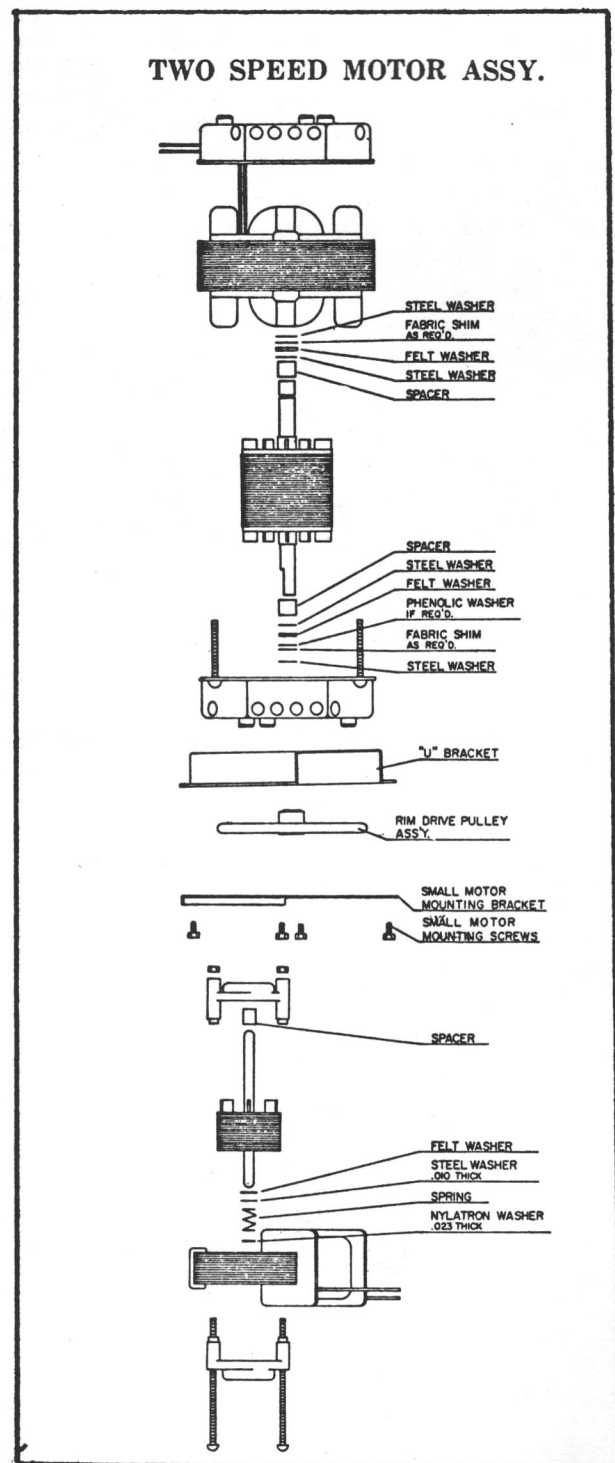

Figure 3-3. Leslie Two-Speed Motor Assembly

all moving parts thoroughly with solvent. Then replace motor assembly in the cabinet by reversing the motor removal procedure.

- c. Before adjusting the rotonsonic drum drive belt, set small motor shaft tension as outlined below.

### 3-13. SMALL MOTOR SHAFT OPERATION AND ADJUSTMENT.—

The small motor drives the shaft of the large motor at slow speed through the rim drive pulley. (See Figure

4-4.) The armature of the small motor is spring-loaded, withdrawing from the rim drive pulley when the small motor is not operating. Whenever the organ is operating with the LESLIE FAST tab in the "up" position, the small motor is activated. The magnetic field created in the small motor laminations forces its shaft into contact with the rim drive pulley to drive the speaker rotor at its "slow" speed. To adjust the contact between the small motor shaft and the rim drive pulley, proceed according to the following:

- a. Be sure LESLIE FAST tab is not depressed.
- b. Loosen the contact adjustment nuts on the small motor until small motor shaft no longer touches the rim drive pulley. (See Figure 4-4.)
- c. Grasp speaker rotor to prevent it from turning.
- d. Slowly tighten the adjustment nuts until the small motor forces the pulley to turn (slip) under the drive belt. (Drive belt must be in proper adjustment. See Paragraph 4-11.)

**NOTE**

Avoid excessive pressure on rim drive pulley.

## SECTION IV MAINTENANCE

**4-1. GENERAL.**—This section contains performance standards information, periodic preventive maintenance schedules, peculiar replacement techniques, and practical service suggestions.

**4-2. PERFORMANCE STANDARDS.**—The performance of the organ should be checked and adjusted in accordance with Table 4-1.

- a. **EQUIPMENT REQUIRED.** — VTVM, Millivolt Commander Model 870, or equivalent. Oscilloscope, Tel-equipment Type S54, or equivalent.
- b. **PRELIMINARY INSTRUCTIONS.**—
  1. **MAIN CHANNEL** measurements to be made with meter connected to green wire on bass speaker and ground. **DO NOT DISCONNECT ANY SPEAKER.**
  2. **LESLIE CHANNEL** measurements to be made with meter connected to pins 24 and 25 of Power Amplifier P. W. B. 124-000162.
  3. Expression pedal at maximum; all tablets in up (off) position; all drawbars pushed in, except as directed for individual steps.
  4. Keys, pedals, and drawbars are called out by number, beginning at left ends of manuals or pedal claviers.

**4-3. LUBRICATION.**—The tone generator and its drive motor should be lubricated once a year **ONLY**. Do not over-lubricate. Use only the special oil supplied by Hammond Organ Co. To lubricate the tone generator, pour approximately 2/10 oz. of oil into each of the two oil cups atop the generator. Pour sufficient oil into each of the motor oiling tubes to fill the tubes. See Figure 4-7.

The two Leslie motors should be lubricated once a year; more frequently if the unit is used several hours per day. Use a good grade of light sewing machine oil. Do not over-lubricate. To determine whether oiling is necessary, press a clean, dry screw-

driver against the felt pads surrounding the motor bearings (two in each motor, Figure 4-4). If oil is transferred to the screwdriver, the bearings should *not* be oiled.

**4-4. REPLACEMENT OF CONTROL TAB.**—In the R-100 organ there are seven separate switch assemblies which comprise the control assembly. When tab replacement is necessary, it is required to work on only the particular assembly containing the tab to be replaced. To replace a tab, remove external parts of console as required for access (see Section III) and proceed according to the following:

- a. Remove black Phillips screws which fasten switch assembly to control panel.
- b. At rear of each switch, remove screws which fasten switch to assembly frame.
- c. Remove black spring clip from end of tab pivot rod (see Figure 4-1).
- d. Lift switch assembly from frame so that pivot rod can be moved. Note positions of any spring clips fastened between tabs. These clips must be returned to original positions when work is completed.
- e. Drive pivot rod as far as possible with a small, light hammer. Then use a 1/8-inch steel rod (another pivot rod, if available) to drive rod through tab to be replaced. When pivot rod has been driven just beyond tab, pull back driving rod sufficiently to permit removal of tab. Remove tab.

### NOTE

In some instances, it may be necessary to loosen and lift adjacent switch assembly to provide space for movement of pivot rod.

- f. Move switch to approximately midpoint of its travel. Insert new tab, making certain that groove in actuating end of tab engages tab tensioning spring in switch frame. See Figure 4-1.



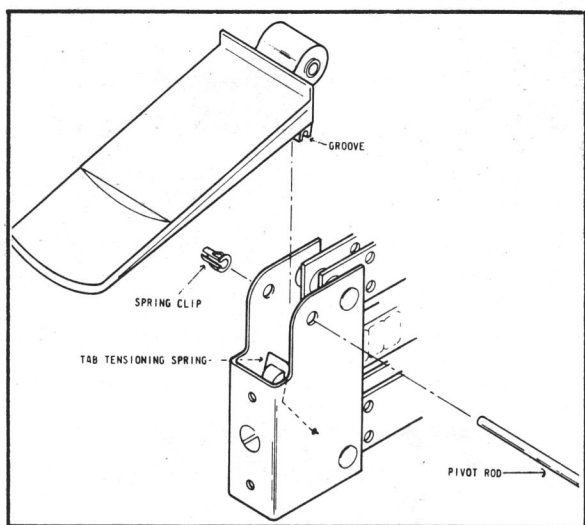

Figure 4-1. Control Tab Replacement

g. Align new tab with holes for pivot rod, and insert driving rod to retain tab temporarily. Drive original pivot rod through tab. Continue driving pivot rod until it has been returned to its original position. Driving rod will drop out.

h. Reattach spring clip removed from end of pivot rod. Return other spring clips, if present, to their original locations.

i. Reseat switch assembly in assembly frame. Reattach screws removed in Steps a and b.

**4-5. REPLACEMENT OF UPPER MANUAL PLAYING KEY.**—To remove an upper manual key, disassemble organ sufficiently for access to upper manual. See Section III. Then proceed according to the following:

- a. To remove a black key, loosen (do not remove) its mounting screw. Disengage key from screw and lift out key.
- b. To remove a white key, loosen its mounting screw and those of adjacent black keys. Disengage black keys from screws, then lift out white key.
- c. Attach new key by reversing removal procedure.

**4-6. REPLACEMENT OF LOWER MANUAL PLAYING KEY.**—To replace a lower manual key, disassemble organ sufficiently for access to lower manual. See Section III. Then proceed according to the following:

- a. Remove organ top assembly. Do not remove control assembly. Loosen and raise upper manual as instructed in Section III, but with control assembly attached.

- b. All key replacement operations are the same as for upper manual keys.

**4-7. REPLACEMENT OF DRAWBAR OR KNOB.**—To replace a drawbar or drawbar knob, the entire drawbar and knob assembly must be removed. Proceed according to the following:

- a. Push drawbar in to limit. Support back end of drawbar from underneath, and remove screw which holds insulator and drawbar to drawbar contact.
- b. Hold contact at rear. Pull drawbar slider and knob assembly out at front. Slider, knob, or both can be replaced easily.
- c. When reinserting slider and knob assembly, be sure studs in insulator engage holes in slider properly.

**4-8. REPLACEMENT OF DRAWBAR ASSEMBLY.**—To replace an entire drawbar assembly, proceed according to the following:

- a. Remove screws which fasten left and right control sections to stop switch base, but do not remove screws which fasten end sections to center section. See Section III.
- b. Tilt controls back for access to drawbars and contacts.

**4-9. REPLACEMENT OF MUSIC ILLUMINATOR LAMP(S).**—To replace one or more of the music illuminator lamps, remove four screws on underside of illuminator assembly (See Figure 4-2). Swing cover of illuminator up for access to lamps (See Figure 4-3).

**4-10. LESLIE MOTOR CLEANING AND LUBRICATION.**—Complete cleaning and lubrication are required when motors have been allowed to run dry or become dirty. It is not necessary to completely disassemble the motors for proper cleaning. A thorough cleaning job can be done with compressed air or a vacuum hose after following motor disassembly procedures given in Paragraphs 3-10 and 3-11. If the motors must be disassembled completely, smooth the large motor shafts with crocus cloth or light filing *before* removing large motor end bells. This will prevent damage to the large motor bearings. Also, mark one edge of the large motor end bell and its corresponding lamination to assure proper reassembly of the motor. Carefully note the

**Table 4-1. Performance Check and Adjustment Procedures, R-100.**

STEP	TEST CHANNEL	DEPRESS TAB(S)	DRAWBAR OR REGISTRATION	PLAY KEY(S) NO. (S)	ADJUST	METER (or other) INDICATION
1	MAIN	DRAWBARS & PERCUSSION	Upper Manual No. 4	25	Level (R427) on P.W.B. 124-000161 (Tone (R407) on P.W.B. 124-000161 should be at midpoint of travel)	0.9V
2	MAIN	As above	Upper Manual No. 9	48	TONE (R407) on P.W.B. 124-000161	480 mv
3	Repeat Step 1, but with Expression Pedal at Minimum					
4	LESLIE	DRAWBARS & PERCUSSION LESLIE ON UPPER	Upper Manual No. 4	25	LESLIE level (R447) on P.W.B. 124-000161	1.7V
5	LESLIE	As above	Upper manual No. 9	48	Leslie TONE control (R435) on P.W.B. 124-000161	900 mv
6	Repeat Step 4, but with Expression Pedal at Minimum					
7a.	LESLIE	DRAWBARS & PERCUSSION LESLIE ON REVERB	Upper manual 000 607 080	13, 14, 15, 16, 17	REVERB LEVEL (R273) on 117-000003	1.4V
b.	LESLIE	DRAWBARS & PERCUSSION LESLIE ON REVERB I	As above	As above	NONE	350mv $\pm$ 1db
c.	LESLIE	As above but REVERB II instead of REVERB I	As above	As above	NONE	880mv $\pm$ 1db
d.	LESLIE	Same as 7a	All upper manual	None	NONE	Hum level 10mv maximum
8a.	MAIN	DRAWBARS & PERCUSSION BANJO	NONE	25, 29, 32	(Disconnect red plug from Percussion Reiteration Driver chassis 128-000001) PERCUSSION LEVEL control (R113) on Percussion Amplifier 117-000001 Reconnect plug after reading.	5.3V

b.	MAIN	As above	NONE	25, 29, 32	(Reconnect red plug.) PERCUSSION CUTOFF control (R112) on Percussion amplifier 117-000001	Signal decays to almost zero
9	MAIN	Disconnect red Reiteration Drive plug and green Main Percussion plug. Ground blue jumper in brown Alternate Percussion plug. Depress MARIMBA and REITERATE tabs and play keys 25, 29, & 32. Turn the Alternate Percussion Level control (R313 on 117-000002) until output reads 1.25V. Set Alternate Percussion Cutoff control (R311 on 117-000002) until signal decays to almost zero. Remove ground from blue jumper. Reconnect red and green plugs. Set REITERATION RATE control to minimum. Play keys 25, 29, & 32. Note the high and low alternate percussion effect. If alternate reiteration times are not equal, delay control (R323 on 117-000002) may require slight adjustment.				
10	MAIN	DRAWBARS & PERCUSSION HARP SUSTAIN	NONE	13, 15, 17	HARP LEVEL (R530) on Harp Pre-amplifier P.W.B. 124-000165	1.8V
11a.	MAIN	CYMBAL PEDAL	NONE	Any pedal repeatedly at 5 strokes per second	CYMBAL LEVEL control (R917) on P.W.B. 124-000020	Maximum swing 4.5V $\pm$ 3db
b.	MAIN	As above	NONE	Any pedal (hold down)	CYMBAL SUSTAIN control (R913) on P.W.B. 124-000020	Maximum swing 4.5V $\pm$ 2db Note If sound is harsh (distorted) decrease to 4.0V maximum
12a.	MAIN	NONE	Pedal Drawbar No. 1	Pedal no. 13	NONE	4.0V $\pm$ 3db
b.	MAIN	NONE	Pedal Drawbar No. 2	Pedal no. 13	Pedal 8' level control (R615) on P.W.B. 124-000137	1.8V
13	MAIN	NONE	NONE	NONE	Music Rack Light "on"	30mv maximum (Hum level)
14	LESLIE	NONE	NONE	NONE	As above	30mv maximum (Hum level)
15	MAIN	Rhythm SOUND	NONE (All Rhythm buttons "off")	NONE	NONE	50mv maximum (Hum level)
16	MAIN	As above	BASS DRUM on Rhythm selector	NONE	Rhythm TEMPO and VOLUME maximum	25V to 35V P-P (Oscilloscope)

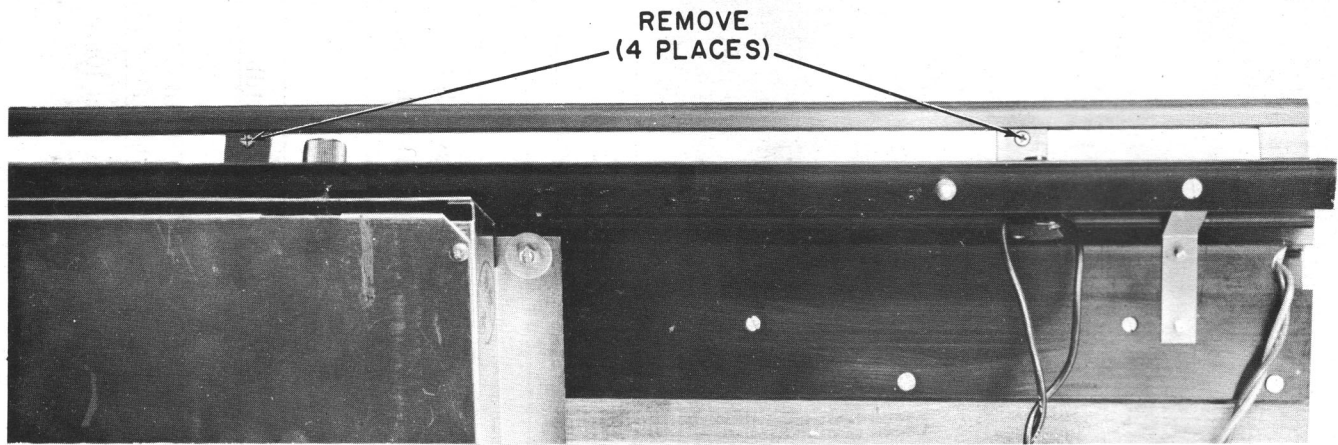

Figure 4-2. Underside of Illuminator

relationship between the field laminations and rotor (armature). Reversing the laminations causes reversed motor rotation. To clean and lubricate, proceed according to the following:

- a. After disassembling motors as previously outlined, remove dust and dirt from end bells of the large motor with compressed air or a vacuum hose. If necessary, clean small motor in the same manner.
- b. Clean all accessible parts with solvent. Allow motors to dry.
- c. Apply enough sewing or other light machine oil to soak the bearings felts of each motor. (See "Oil Hole" and "Oil Felt" points on Fig. 4-4.) Don't add more oil than these felts will readily absorb. This completes cleaning and lubrication of the two-speed motor assembly.

**4-11. LESLIE DRIVE BELT ADJUSTMENT.**—The rotor drive belt should be adjusted so that the motor pulley slips slightly on starting, the rotor reaching full speed in about 15 seconds. If it does not, loosen the motor mounting wing nut, pull the motor away from the drum until the rotor drive belt becomes taut, and gently release the motor. Tighten motor mounting wing nut with motor in this position. Re-check adjustment and repeat this procedure if necessary.

**4-12. MAINTENANCE OF LESLIE ROTARY CONTACT (MERCOTAC).**—The Mercotac is a noiseless two-circuit rotary contact assembly providing the electrical connection for the 6 x 9 speaker in the rotonic drum. It uses mercury as its contact medium to avoid the noise usually produced by sliding contacts. If the Mercotac is jarred or inverted, mercury may be dislodged from

its well at the contact's base. The speaker in the rotonic drum will then become noisy or inoperative.

- a. Mercotac Removal.—
  1. Remove the plastic cap assembly from the rotary contact by pulling straight up.
  2. Twist and pull rotary contact off the rotonic drum shaft.
- b. Checking the Two Circuit Rotary Contact.—
  1. While holding the rotary contact in an upright position, spin the upper center section three or four times.

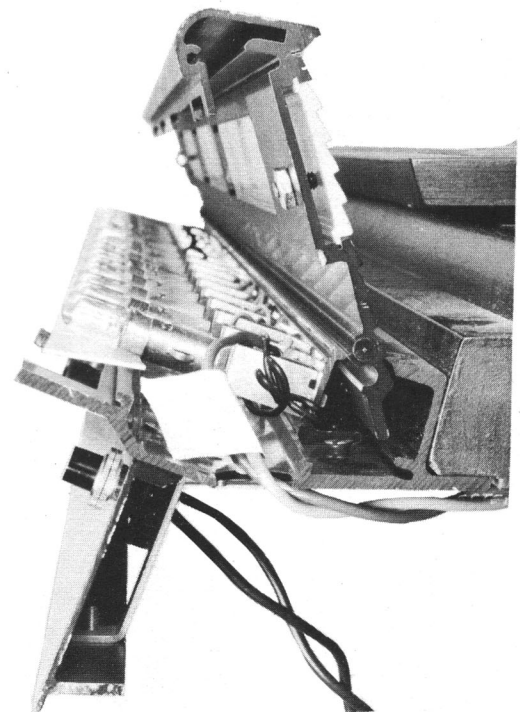

Figure 4-3. Illuminator, Cover Open

2. Using an ohmmeter, check for complete continuity between top

and bottom center contacts; then top and bottom outer contacts. (See Fig. 4-5.) Ohmmeter should read less than 1 ohm.

3. Check for no continuity (infinite resistance) between the center and outer contacts. (See Fig. 4-5.) If continuity is observed and spinning does not clear the contact, reseal the mercury as you would clear a fever thermometer. Hold the rotary contact with the fingertips, the funnel shaped end pointing away from the palm of the hand. Then apply centrifugal force, swinging the arm downward with a final wrist snap. If this does not clear the contact, it is probably defective and should be replaced.

c. Attaching Two Circuit Rotary Contact.—

#### NOTE

A defective contact should be replaced. Carefully seat the contact on the shaft of the rotonic drum. Make certain the arrow on the contact points toward the drum. (See Fig. 4-5.) Press the contact onto the shaft.

#### WARNING

Do not attempt to disassemble or heat Mercotac. High heat could vaporize the mercury. Mercury vapor is highly poisonous.

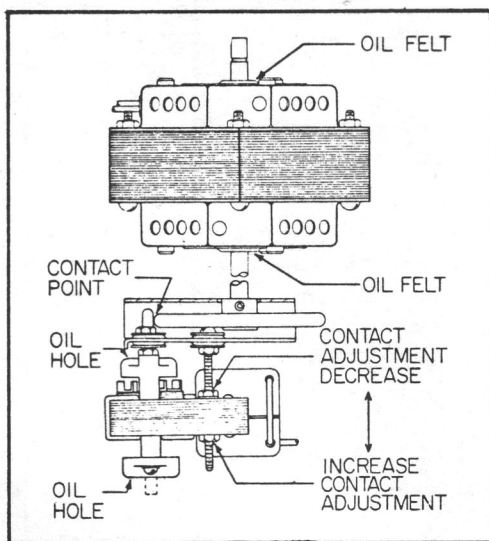

Figure 4-4. Leslie Motor Lubrication and Adjustments

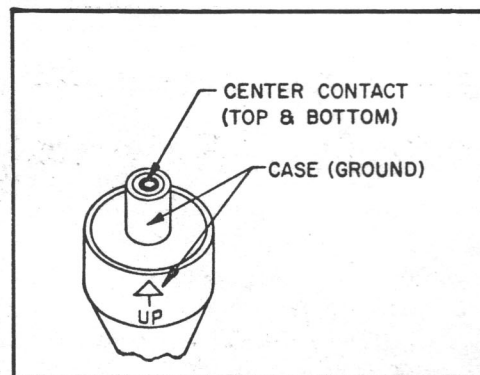

Figure 4-5. Mercotac

**4-13. PRACTICAL SERVICE SUGGESTIONS.**—The following paragraphs describe techniques to be used in tracing and correcting possible malfunctions.

**4-14. ORGAN DOES NOT PLAY.**—Be sure power switch is “on.” Push music light switch. If lights do not go on, check power wiring, line cord, wall outlet. If music lights operate, check organ power switch.

**4-15. ONE KEY DOES NOT PLAY OR A HARMONIC IS MISSING.**—The cause of these malfunctions may be a dirty key contact, a broken connection, or a “dead” note in the generator. The following steps will aid in isolating the specific cause.

- a. Ordinarily only one of the several frequencies used on the key will be missing. This can be determined by holding a key and operating each drawbar for the corresponding manual, observing on which drawbar the key fails to play. Reference to Table 2-2 will tell which frequency number is missing.
- b. Determine whether the same frequency is missing where it is required on other keys of the same manual. Consult Table 2-2 for key/drawbar combinations using the same frequency. If the frequency is missing from only one key, a dirty key contact is the probable cause. In some cases the contact can be cleared by striking the key 15 or 20 times in a rapid staccato manner to loosen the dirt. If this is not effective, move the busbar shifter for the corresponding manual. For locations of busbar shifters see Figure 3-2. Moving the shifter will slide the busbars endwise to present a clean contact surface. In extreme cases it may be necessary to hold down the faulty key while shifting the busbars.

- c. If the frequency is missing on all keys of one manual but not on the other manual, look for a break in the cable connecting one manual to the other.
- d. If the frequency is missing on both manuals, check the manual-to-generator cable or the generator itself.
- e. The output of any single frequency on the tone generator may be checked by connecting a clip lead from any drawbar to the generator terminal in question. Pull out drawbar. See Figure 2-3 for locations of frequencies on generator terminals. If the generator is all right, the note will play loudly.

### CAUTION

Never test the tone generator with an outside source of current such as a continuity meter, as serious damage may result to the sensitive filter transformers and permanent magnets. By the above method, all necessary tests of the tone generator may be made with the current supplied by the generator itself.

- f. If the note fails to play, try touching the clip to the input side of the filter coil (not the grounded tap) and the input side of the filter condenser (Figure 2-3) in order to check these parts. Disconnect the condenser to eliminate the possibility of a grounded transformer. If the signal is still missing at the magnet coil terminal, it means that the tone wheel is not turning, the coil is defective, or the magnet is not properly adjusted.
- g. If the tone wheel is not turning, the frequency of the other wheel on the same shaft will also be missing (with the exception of a few wheels which are alone). On the generator magnet location diagram, (Figure 2-2), the two frequencies whose numbers are connected by a dotted line are on the same shaft. The wheels may also be checked by raising the generator and observing them. Each wheel is located directly behind its magnet, shown in Figure 2-2.
- h. If the magnet coil is defective, the generator must be returned to the factory, as replacement of a coil necessitates dismantling the entire generator.
- i. It is possible, although unlikely, that

the magnet may have become loose and moved sufficiently far from the wheel to make the note inaudible. It may be adjusted as described in the following paragraph.

### 4-16. ONE NOTE IS WEAK.—

- a. Trace the note, as described in the preceding section, to see whether weakness is due to dirty contact, poor connection, defective filter, or reduced output of magnet coil. Check at each point by comparing intensities with higher and lower frequency numbers.
- b. It is possible that one or more notes may be acoustically weak, due to the room and the furnishings, although the actual signal level is equal to that of adjacent notes. This can be checked by reading voltages of the various notes on an output meter connected to green wire on bass speaker and ground.
- c. Each magnet is set at the factory, with the set screw partially loosened, while observing an output meter. Experience has shown that the magnets seldom need adjustment and that setting them without proper equipment involves danger of damaging both magnet and wheel.

### CAUTION

When making adjustment, do not allow magnet to touch wheel.

- 4-17. ONE PEDAL DOES NOT PLAY.—**A missing pedal note can be traced to pedal switch contacts, sine wave amplifier, pedal keyer, or to the generator. Before checking other circuits, be sure the missing frequency (16' or 8', applicable) is being supplied by the generator. See Paragraph 4-5, e. Also check wiring to generator. If generator output and wiring are satisfactory, check for +35V approximately at pin 9 of the corresponding keyer when the pedal is depressed. See Figure 5-3. If no voltage is present, check wiring to pedal switch and the switch itself. If keying voltage is present, release pedal and jumper pins 1 and 2 of 16' keyer or pins 1 and 8 of 8' keyer, as applicable. See Figure 5-3. If note sounds, keyer printed network is defective. Replace. If note does not sound, fault is in the corresponding sine wave amplifier or the coupling capacitor. Check and replace

the amplifier printed network or capacitor, as required.

**4-18. HARP CIRCUIT CIPHERS.**—There are 49 harp effect keyers, starting at C2 (playing key 13) of the upper manual, and ending at key 61. These harp keyers will be referred to as numbers 1 through 49 for the sake of simplicity, although they do not correspond to the generator frequencies used to produce the harp effect, nor to the frequency numbering system. Locate the harp keyer number by starting at either the high end of the keyboard, or C2 (key 13), whichever is closest to the pitch of the cipher. Depress the HARP SUSTAIN tablet and count the number of keys between the starting point and the key which zero beats, in pitch, with the cipher.

Example: The fifteenth key above C2 (key 13) zero beats in pitch, with the cipher. C2 (key 13) is Harp Keyer #1. One plus 15 = 16. Therefore Harp Keyer #16 is at fault. Conversely, if key #5 (counting down from key 61) zero beats, in pitch, with the cipher, Harp Keyer #44 is at fault. (49 minus 5 = 44.)

Position Harp Assembly so that all terminals are easily viewed, and so that the shielded cables are at the bottom left of the harp frame.

The Harp Keyers are numbered from top to bottom with the 49th keyer the bottom-most of the group of 5 keyers on the left-hand printed wiring board. Keyer #1 is at top right of the frame. See Figure 2-5.

There are two terminal posts for each keyer. The one on the left side of the P.W.B. is the signal input—the one on the right—keying. All wires to signal input terminals are of one color. Two colors are alternated in the keying cabling. No specific colors are given, since they may vary.

Use a jumper with alligator clips at each end, and ground the signal input terminal of the suspect keyer to the generator frame. The cipher should now stop.

Next, unwind the wire-wrap to the keying terminal of the suspect keyer and check for voltage between the disconnected wire and ground. There should be zero volts with no key depressed. If voltage is present (approx. 100 V DC), this indicates an internal manual short between the Brush/

Cymbal keying and Harp keying busses. In most cases, no voltage will be read and the transistor in the keyer circuit may be replaced.

Insure that all removed wires are *soldered* back on.

**4-19. BRUSH DOES NOT SOUND (See Figures 5-1 and 5-5).**—If the Brush does not sound when the BRUSH LOWER tab is depressed, and a lower manual key is played, the fault could be in one of the following: keying transistor Q901, tab switch contacts or wiring, playing key contact, D801, C805.

To isolate the fault, check the circuit as outlined below.

- a. If the sound is missing from one key only, check key contact and 220K resistor at keying bus. If sound is missing from all keys, check further.
- b. Connect an oscilloscope to pin 1 of Brush and Cymbal board 124-000020. Set vertical response for 0.2 v/cm; sweep for 2ms/cm. With BRUSH LOWER tab depressed, waveform (keying pulse) shown in Figure 5-5 should be seen each time a lower manual key is played.
- c. If the pulse is present, the fault is probably in Q901, the keying transistor.
- d. If the pulse is not present, check tab switch contacts. Check C805 for short. With no key depressed there should be approximately 550 mv D. C. at pin 1 of board 124-000020.
- e. If DC voltage is missing check D801 for open condition. Check +22V input to D801.
- f. If Brush is heard when playing one key, and is silent when key is held down and other lower manual keys are played, check dressing of 220K on key being held. The bus side of the resistor may be shorted to ground.

**4-20. CYMBAL DOES NOT SOUND. (See Figures 5-1 and 5-5).**—If the Cymbal does not sound when the CYMBAL PEDAL tab is depressed, and a pedal is played, the fault could be in one of the following: Pedal switch contacts, tab switch contacts or wiring.

- a. Check for +6V at pin 6 of Brush and Cymbal board 124-000020 when a pedal is depressed. If voltage is miss-

ing, check tab switch and associated wiring.

- b. If Cymbal is missing from only one pedal, check pedal switch contacts.

**4-21. NO CYMBAL OR BRUSH.**—If checks of paragraphs 4-19 and 4-20 do not reveal source of malfunction, the Cymbal/Brush board circuitry must be checked.

**4-22. HARMONIC MISSING (UPPER MANUAL).**—To check for a missing harmonic, interconnections between keys, tabs and drawbars must be checked. To locate the missing harmonic, so that further search can be localized, proceed according to the following:

- a. Depress upper manual DRAWBARS AND PERCUSSION tab.
- b. Depress CHIMES tab and play upper manual key No. 25, holding down the key after the voice decays. While holding the key down, pull each of the nine upper manual drawbars, one at a time. Each drawbar should produce one of the harmonics. If any of the drawbars fails to produce a tone, the contacts associated with that drawbar and the tab should be checked.

The third through sixth drawbars in the group of nine are connected to their associated switches by means of color-coded wires. Check all switch contacts connected with wire of the same color as that connected to the drawbar.

If no sound is produced by the first, second or ninth drawbar, check connections at P803, and at the switch actuated by the DRAWBARS & PERCUSSION tab. The same checks apply to the remaining drawbars, if examination of the color-coded connections does not reveal the source of trouble.

Also, check primaries of T101, Figure 5-1 for continuity.

- c. Repeat above, depressing four remaining percussion tabs, one at a time.

**4-23. PRESET VOICING.**—Each of the organ preset voices should have a distinctive sound, corresponding to a specific drawbar registration. If any of the voices does not sound normal, check in the following manner.

Refer to Figure 5-1. Above each of the tabs, its corresponding drawbar registration is indicated. In order to check a preset, set up its registration on the drawbars for the manual being checked. Play a C-E-G chord on the manual, using the preset tab being checked. Listen carefully to the tone quality. Depress the DRAWBARS tab and repeat the C-E-G chord. The tone quality should be unchanged.

If the sounds are not identical, look for misadjusted tab switch contacts.

**4-24. HUM.**—

- a. A loud 60 Hz or 120 Hz hum in the speaker may come from some nearby electrical appliance. It may be picked up by the matching transformer, or the console wiring. It may be eliminated by moving either the console or the appliance.
- b. Any other 60 Hz or 120 Hz hum must originate within the console and can generally be eliminated by replacing one or more of the electrolytic condensers in the power supply.

**4-25. PARTS LOCATION.**—Figures 4-6 through 4-8 serve as a guide to the locations of parts in the organ.



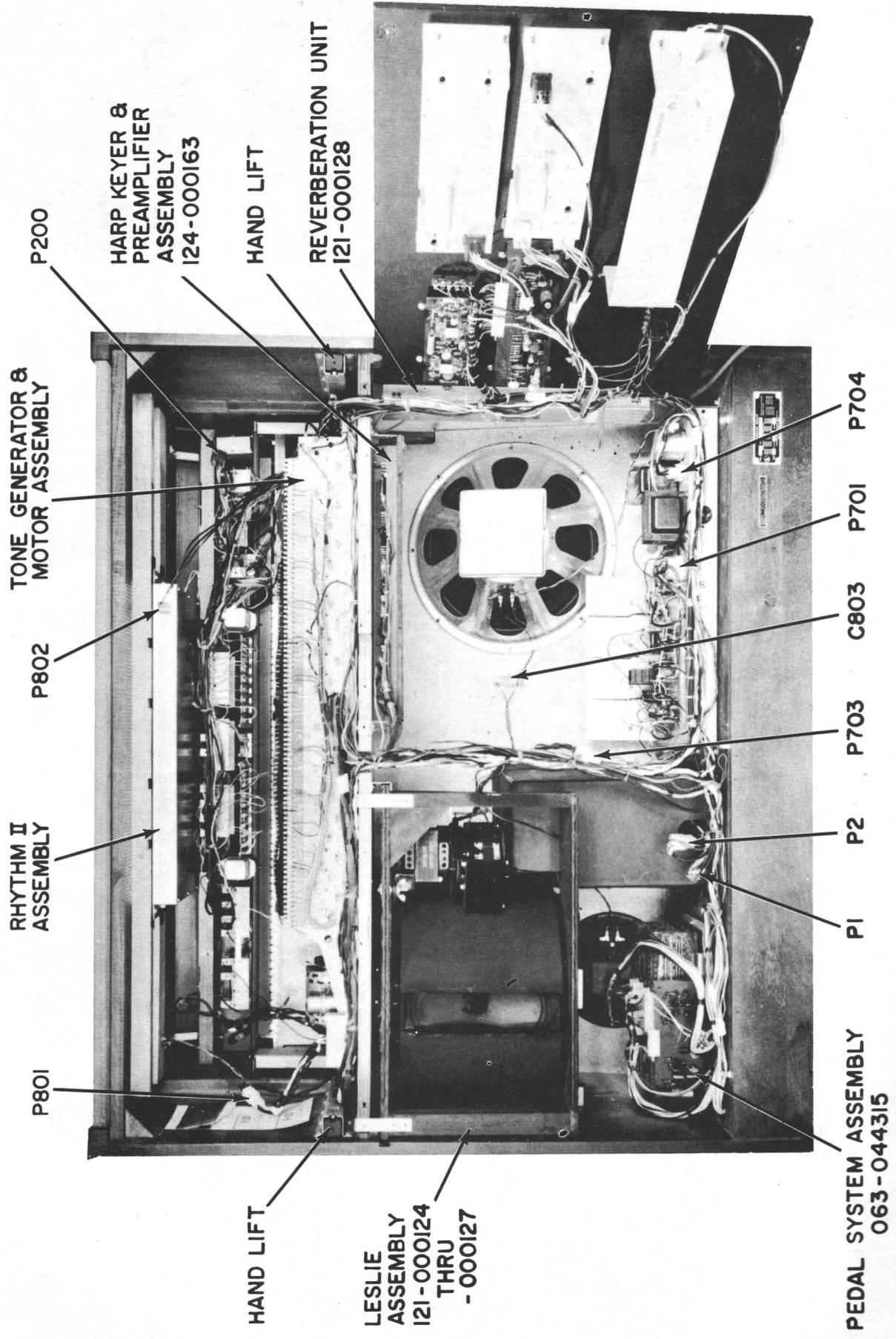

Figure 4-6. Parts Identification, Rear of Console

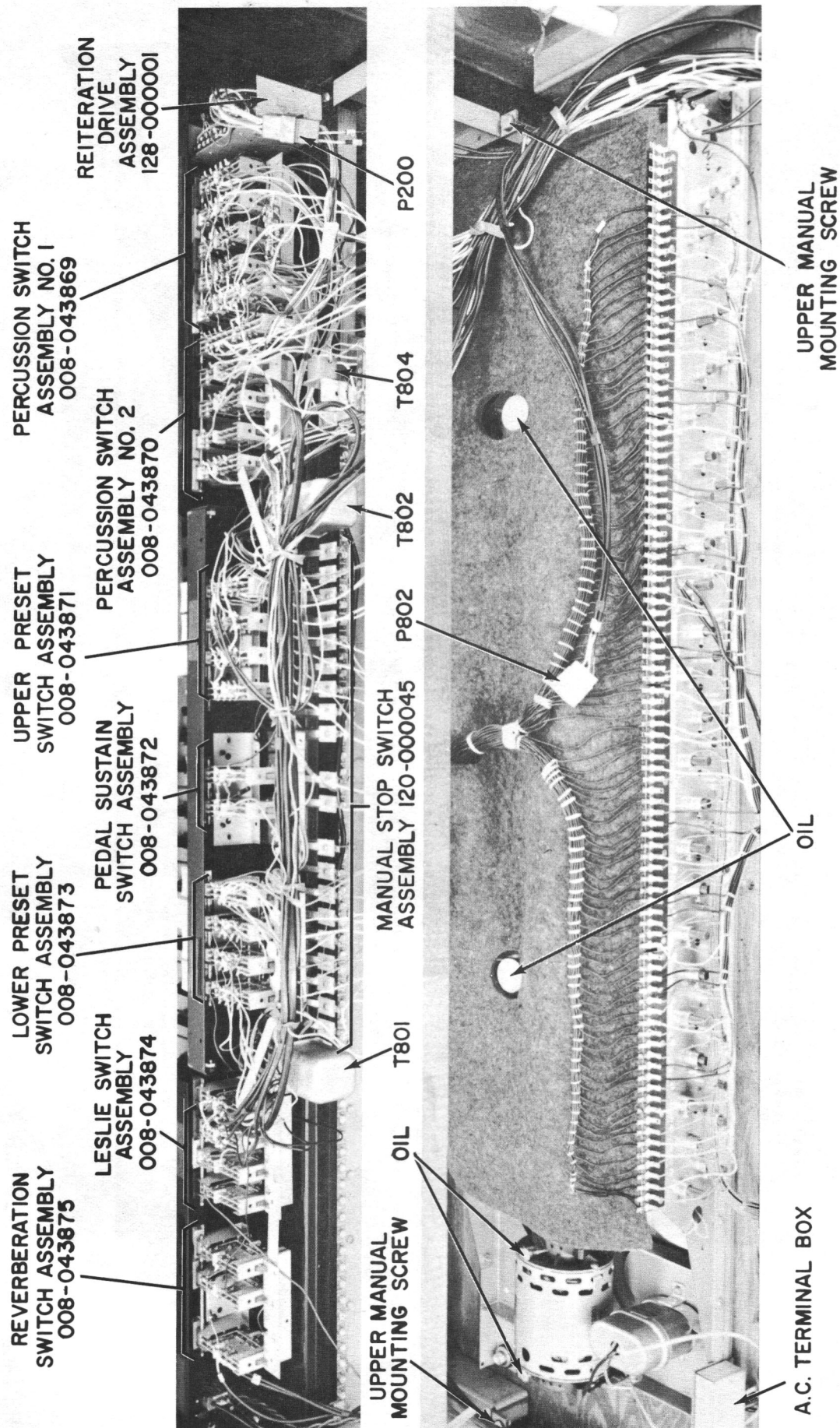

Figure 4-7. Parts Identification and Lubrication Points, Rear of Console

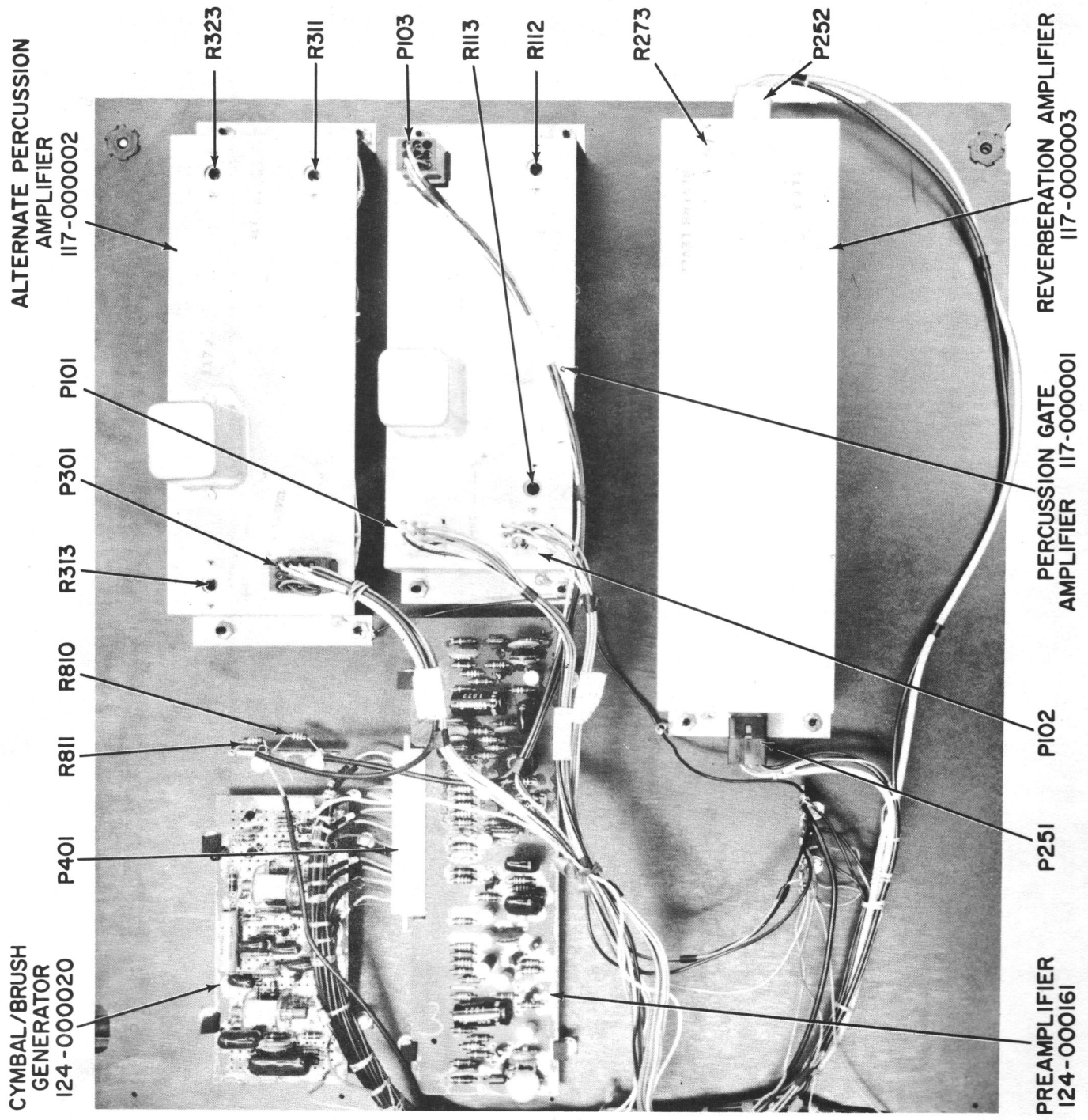

Figure 4-8. Parts Identification, Fold-Out Panel



## SECTION V DIAGRAMS

- 5-1. GENERAL.** – This section contains schematic diagrams to illustrate the text and provide information necessary to proper organ servicing.

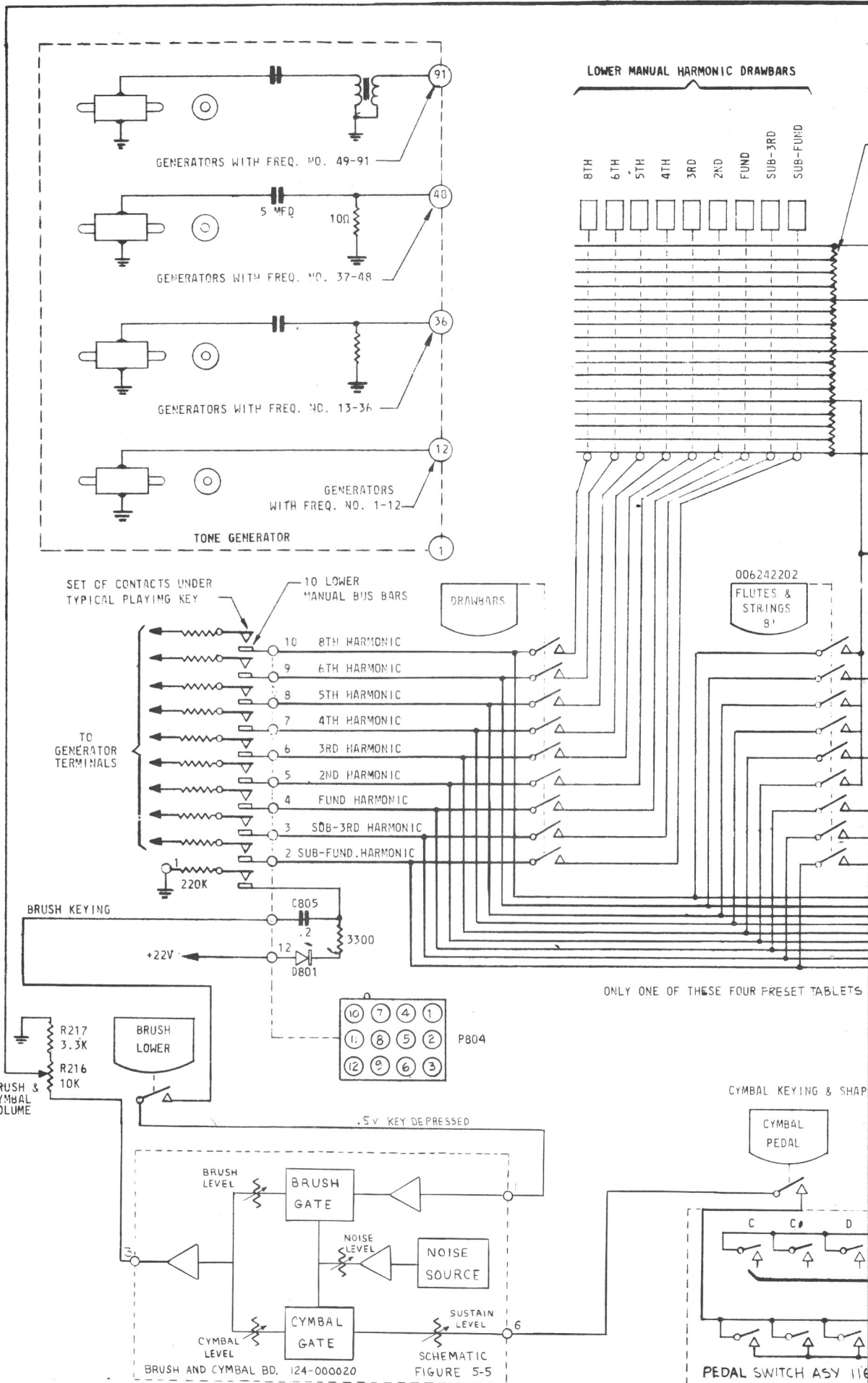
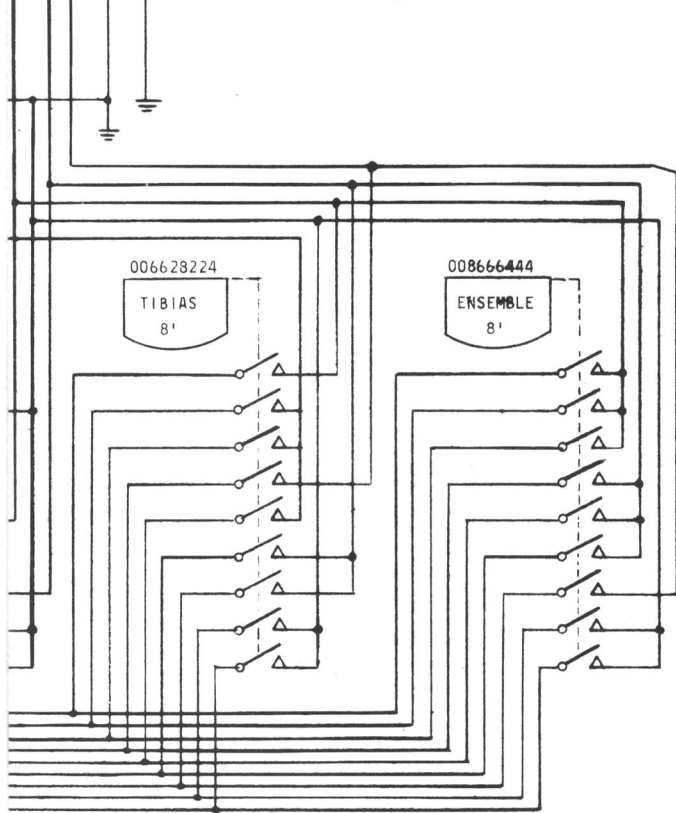
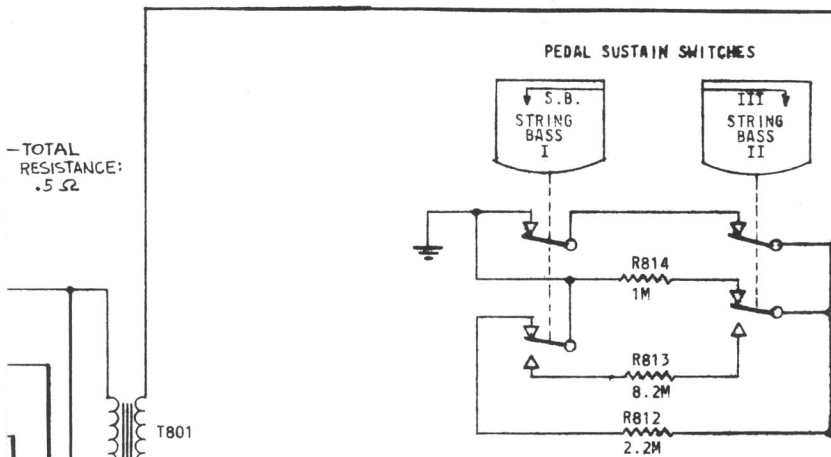

Figure 5-1. R-100 Organ, Schematic Diagram, Sheet 1 of 3

CYMBAL SIGNAL →



CAN BE DEPRESSED AT ONE TIME

FROM GENERATOR  
FREQUENCIES  
1 THRU 37  
VIA  
P601 AND P602

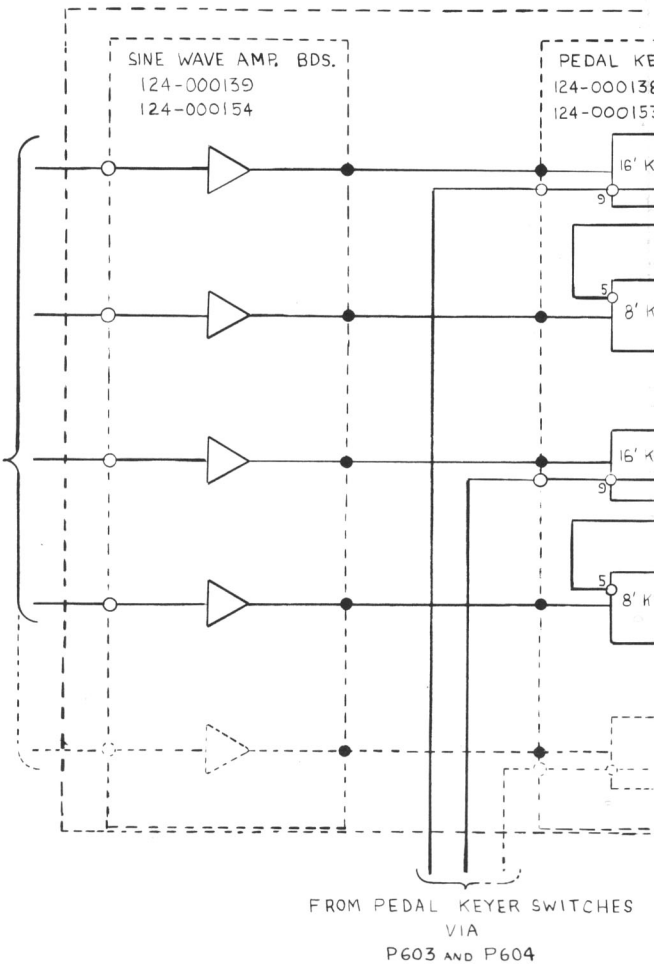

ING

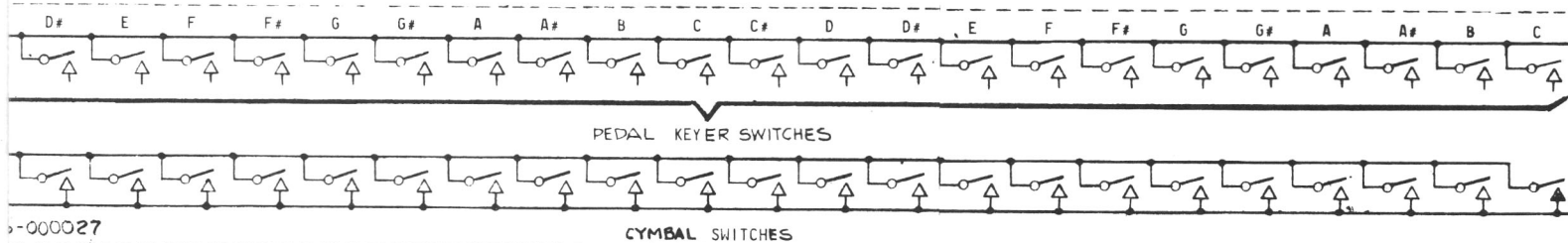

TO SWELL PEDAL BD.  
124-00046 PIN 10

TO ON LOWER  
TABLET

SEE SHEET 3 OF 3

R800  
120K

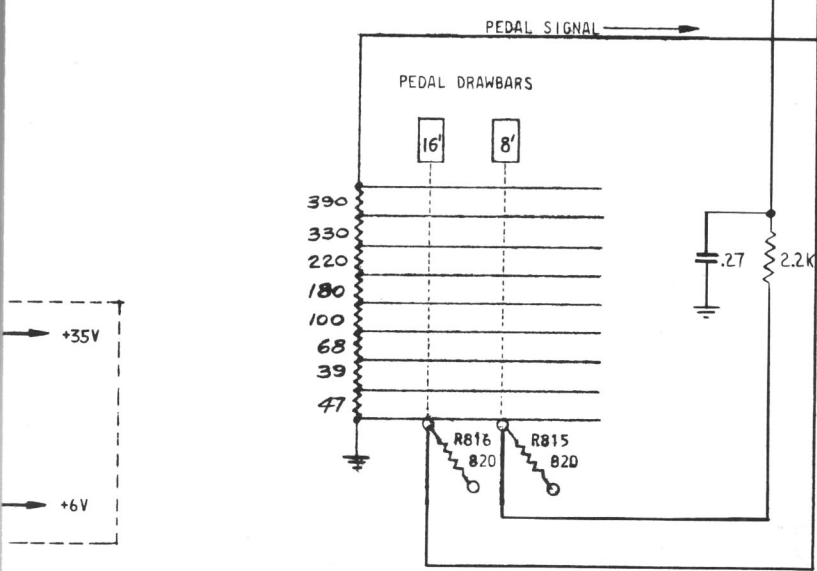
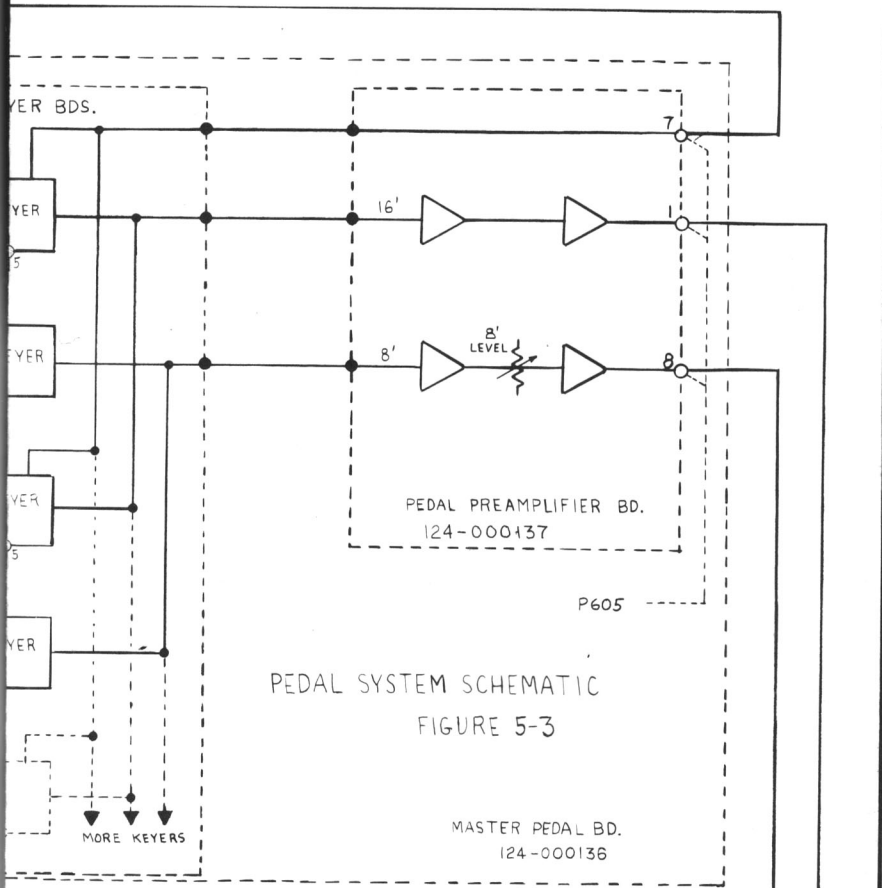



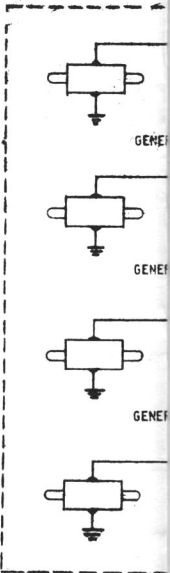

12 UPPER MANUA

SET OF CONTACTS  
TYPICAL PLAYING

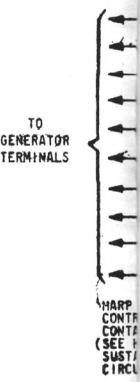

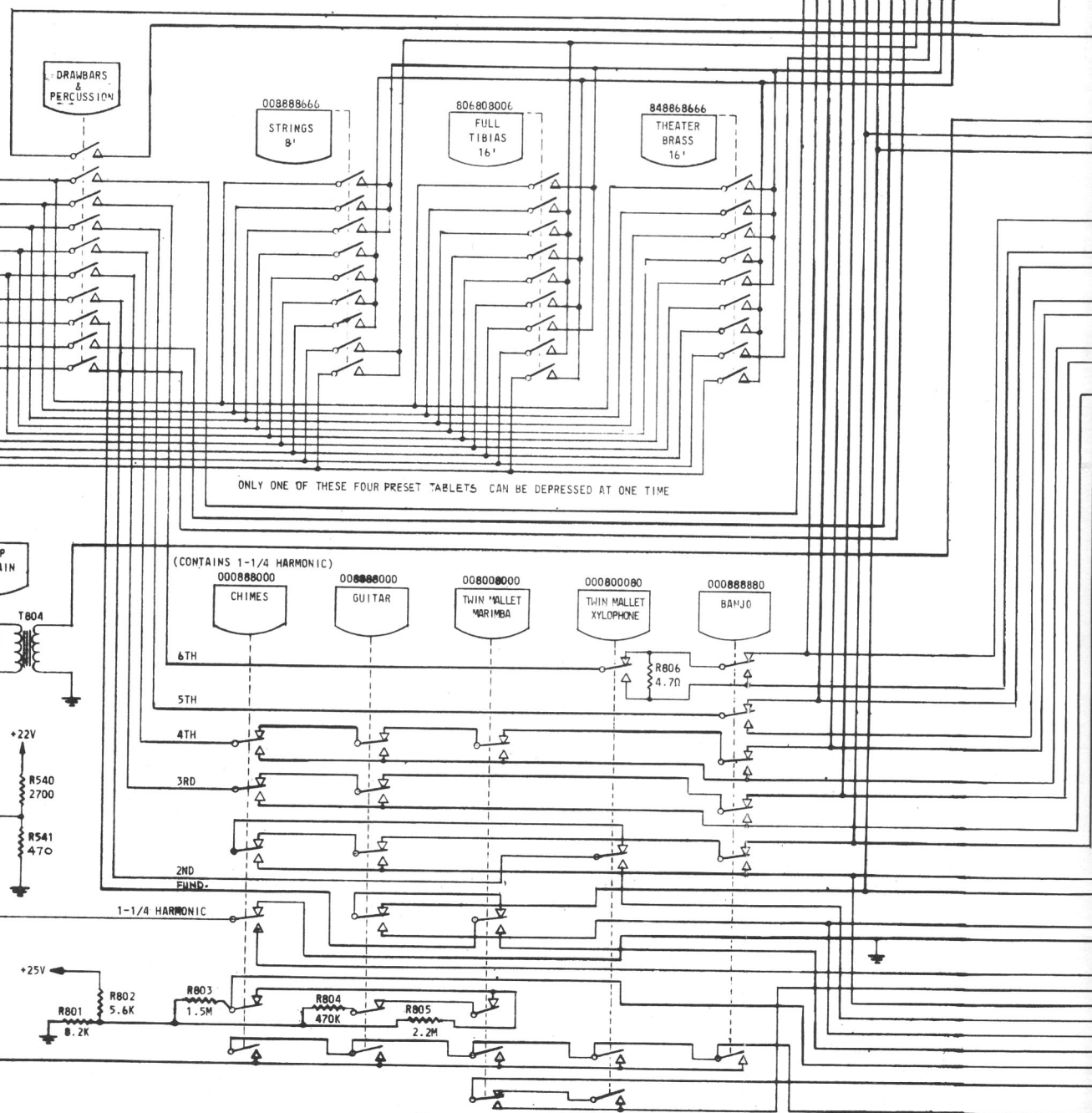
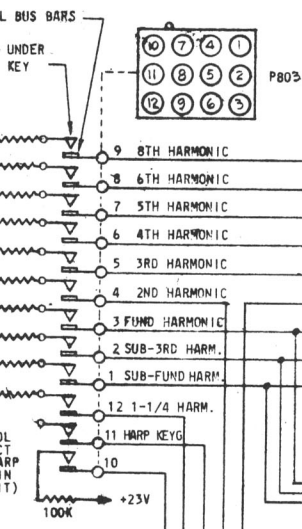
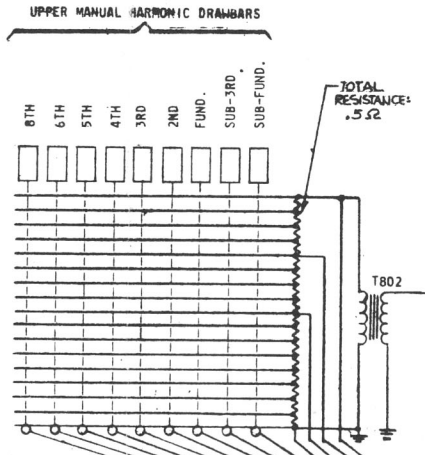
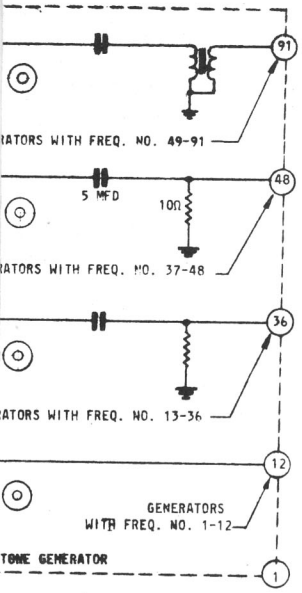

ARMONIC DRAWBARS

3RD  
2ND  
FUND.  
SUB-3RD  
SUB-FUND.

TOTAL RESISTANCE: .5 Ω

T802

FROM TONE GENERATOR  
FREQUENCIES 37-85



HARP KEYING FROM  
UPPER MANUAL

NON SUSTAIN HARP SIGNAL

HARP SUSTAIN KEYS  
BOARD ASSEMBLY  
124-000183

FIG. 5-24

NOTES:

1. UNLESS OTHERWISE SPECIFIED:
  - (a) ALL RESISTORS
  - (b) ALL CAPACITORS
2. SYMBOL  DEMO
3. SYMBOL  DEMO
4. SYMBOL  DEMO
5. COMPONENTS NUMBERED 1 THROUGH 12
6. A.C. VOLTAGES (R.M.S.)
7. ALL INDICATED D.C.
8. EXTERNAL VIEW

R811  
270K

R810  
270K

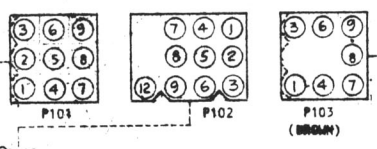

PERCUSSION AMPLIFIER  
117-000001

FIG. 5-8

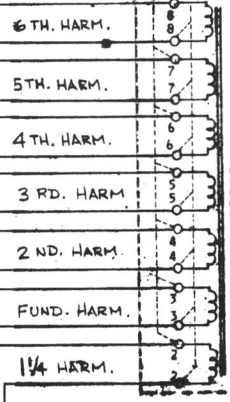

PERC. GATE CONTROL

PERC. LEVEL

PERC. CUTOFF

REITERATE

2ND

FUND.

+25V

TO PERC. DECAY RESISTORS

REIT. OUTPUT

REITERATION ON

REIT. D.C. KEYING

LEGATO D.C. KEYING

NOT USED

NON-REITERATION

D.C. KEYING

+25V

12

8

9

7

5

1

2

3

4

RATE CONTROL

PERCUSSION

TO LESLIE ON UPPER SWITCH  
 TO ADD LESLIE SWITCH  
 SEE SHEET 3

- NOTES:
- UNLESS OTHERWISE SPECIFIED:  
 (a) ALL RESISTORS 1/2 WATT WITH THEIR RESISTANCE VALUES IN OHMS,  $\pm 10\%$ .  
 (b) ALL CAPACITORS WITH DECIMAL VALUES IN MICROFARADS.
  - SYMBOL  $\textcircled{7}$  DENOTES NUMBERED PIN ON P.W. BOARD.
  - SYMBOL  $\textcircled{2}$  DENOTES NUMBERED PIN IN PLUG OR RECEPTACLE.
  - SYMBOL  $\nabla 7$  DENOTES NUMBERED PIN IN STRAIGHT ON CONNECTOR.
  - COMPONENTS NUMBERED 0 THRU 99 ARE LOCATED IN THE SWELL PEDAL, POWER AMPLIFIER AND ACTIVE FILTERS.  
 COMPONENTS NUMBERED 100 THRU 199 ARE LOCATED IN THE PERCUSSION AMP. CIRCUIT.  
 COMPONENTS NUMBERED 200 THRU 249 ARE LOCATED IN THE PERCUSSION & REIT. CIRCUITS.  
 COMPONENTS NUMBERED 250 THRU 299 ARE LOCATED IN THE REVERB. AMP. CIRCUIT.  
 COMPONENTS NUMBERED 300 THRU 399 ARE LOCATED IN THE ALTERNATE PERC. BD. CIRCUIT.  
 COMPONENTS NUMBERED 400 THRU 499 ARE LOCATED IN THE PREAMPLIFIER CIRCUIT.  
 COMPONENTS NUMBERED 500 THRU 599 ARE LOCATED IN THE HARP CIRCUIT.  
 COMPONENTS NUMBERED 600 THRU 699 ARE LOCATED IN THE PEDAL SYSTEM CIRCUITS.  
 COMPONENTS NUMBERED 700 THRU 799 ARE LOCATED IN THE POWER SUPPLY (PART OF AMPLIFIER CHASSIS.)  
 COMPONENTS NUMBERED 800 THRU 899 ARE LOCATED IN THE CONTROL & MISC. CIRCUITS.  
 COMPONENTS NUMBERED 900 THRU 999 ARE LOCATED IN THE BRUSH & CYMBAL CIRCUITS.
  - A.C. VOLTAGES (R.M.S.) MEASURED WITH EXPRESSION PEDAL IN MAX. POSITION.
  - ALL INDICATED D.C. VOLTAGES ARE MEASURED TO GROUND, USING A V.T.V.M.
  - EXTERNAL VIEW OF ALL PLUGS AND RECEPTACLES SHOWN.

KEYERS  
 ASSEMBLY  
 163  
 -24

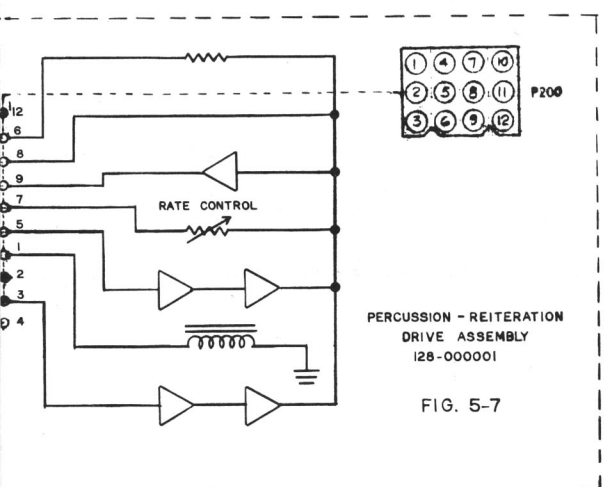
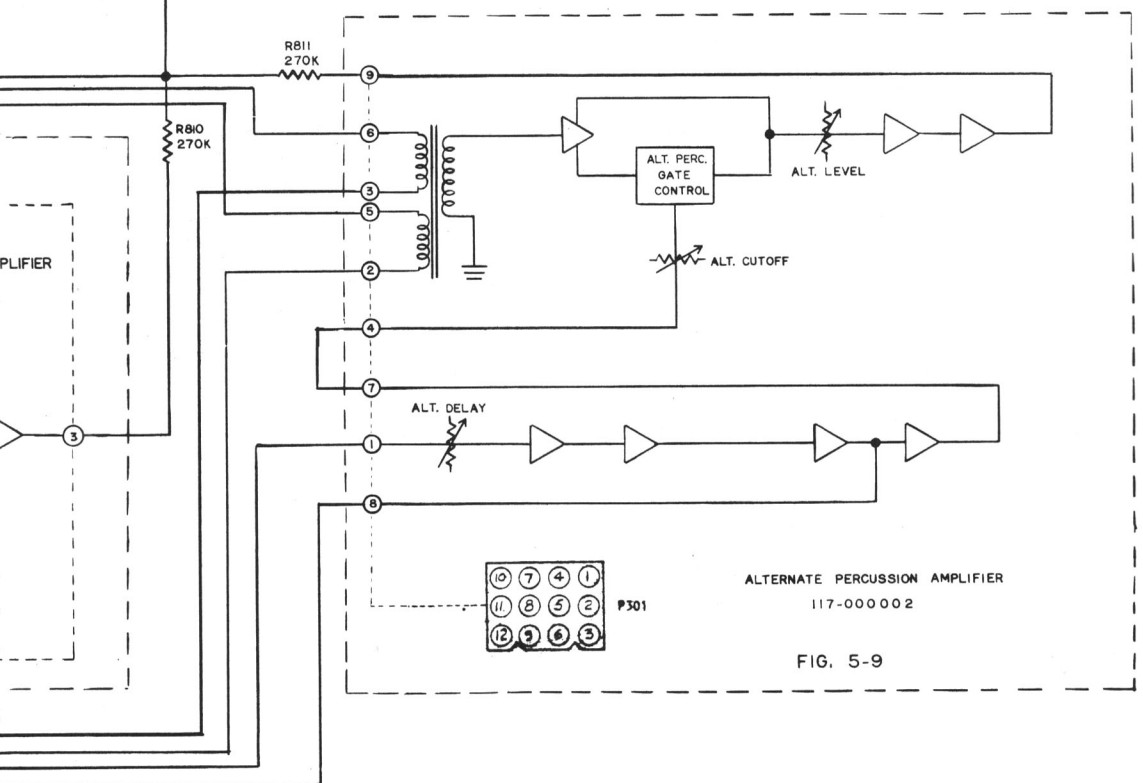
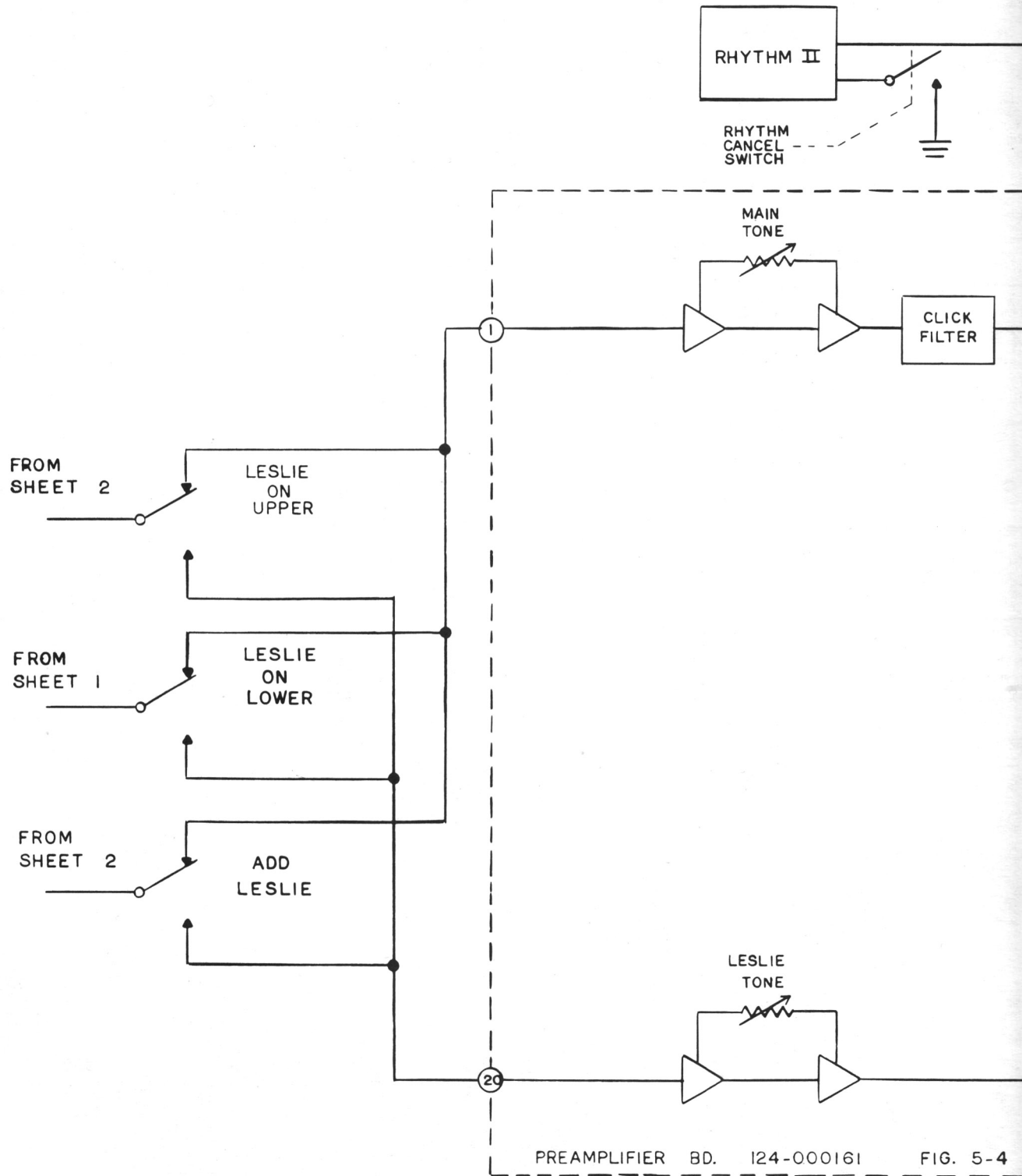
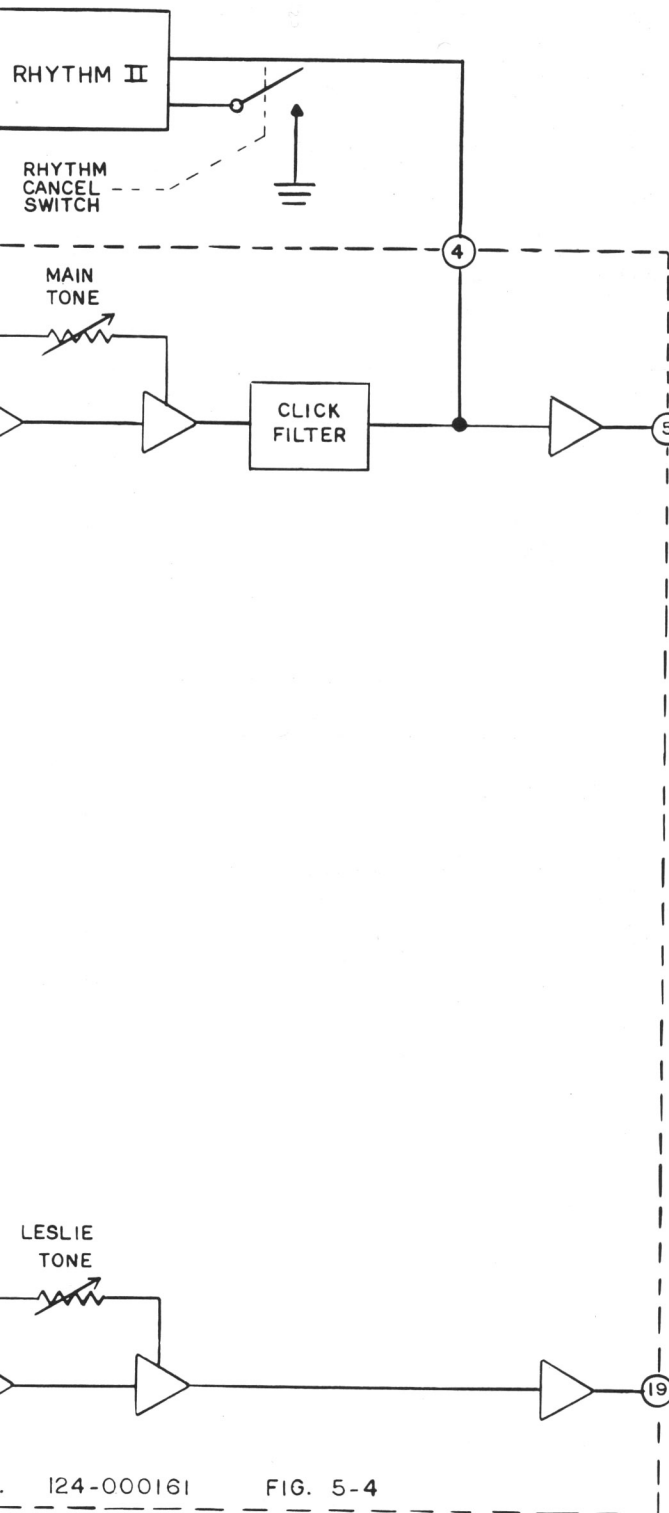

Figure 5-1. P







124-000161 FIG. 5-4

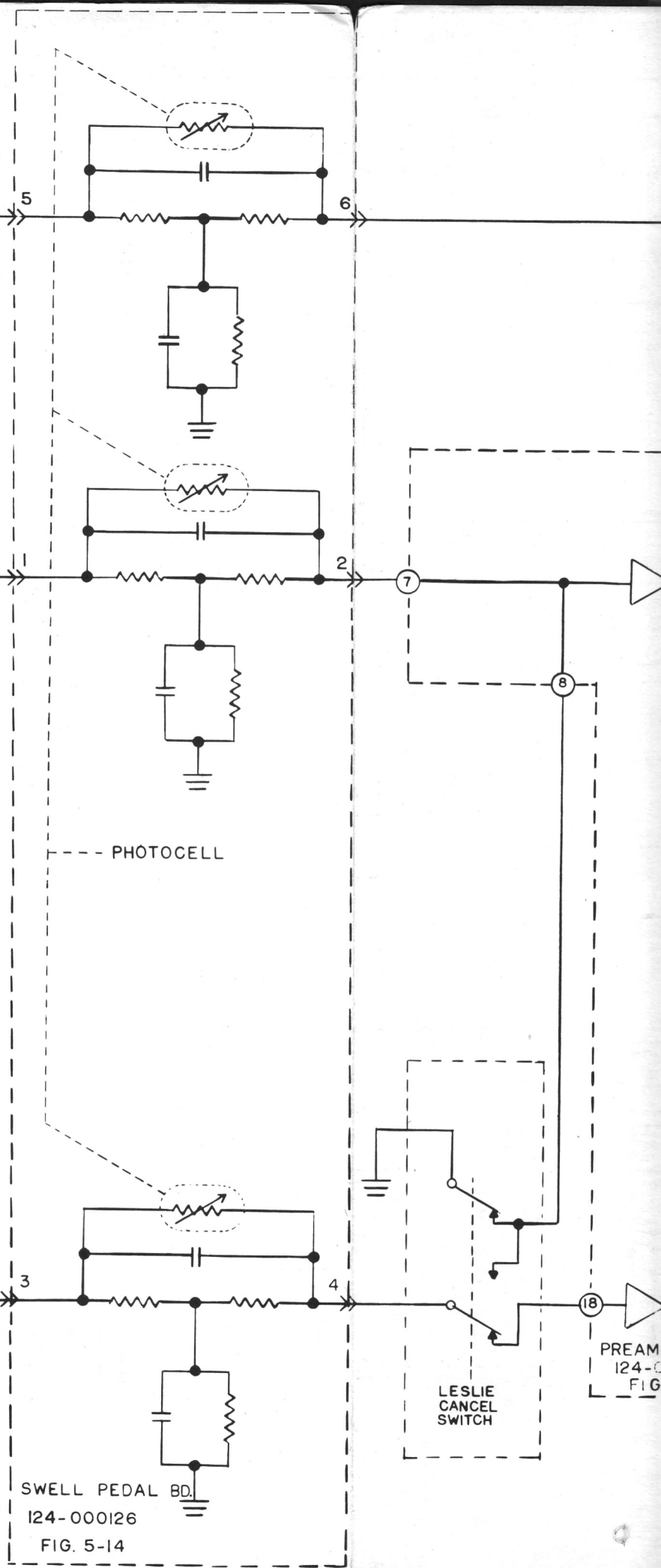

SWELL PEDAL BD.  
124-000126  
FIG. 5-14

PREAM  
124-0  
FIG

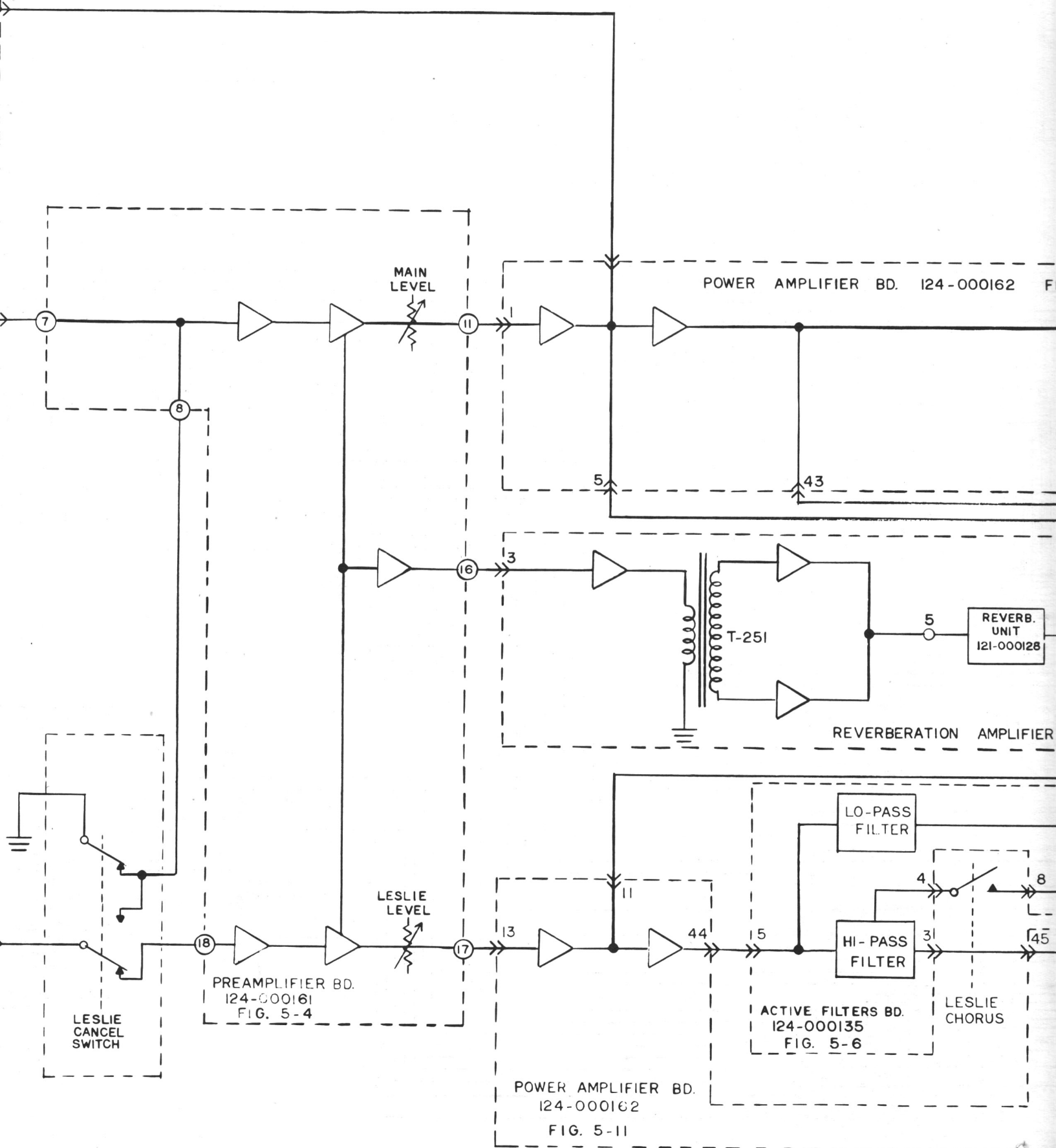



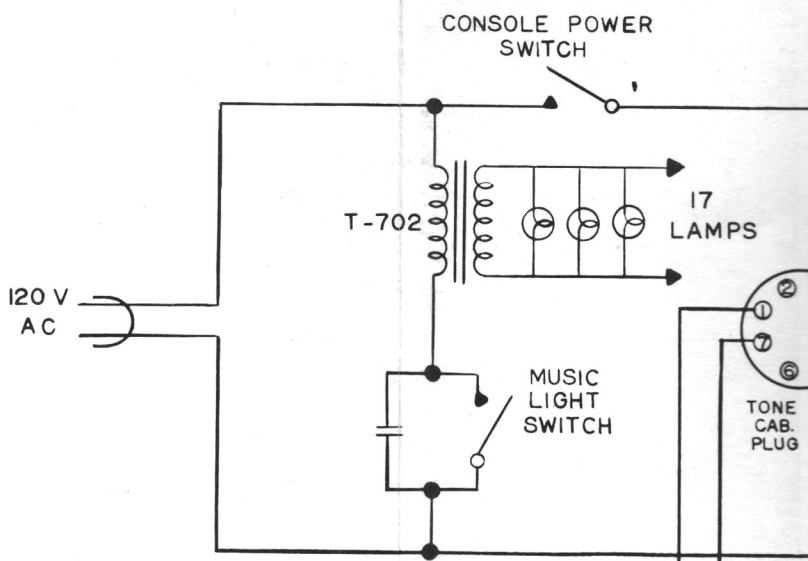

AMPLIFIER BD. 124-000162 FIG. 5-11

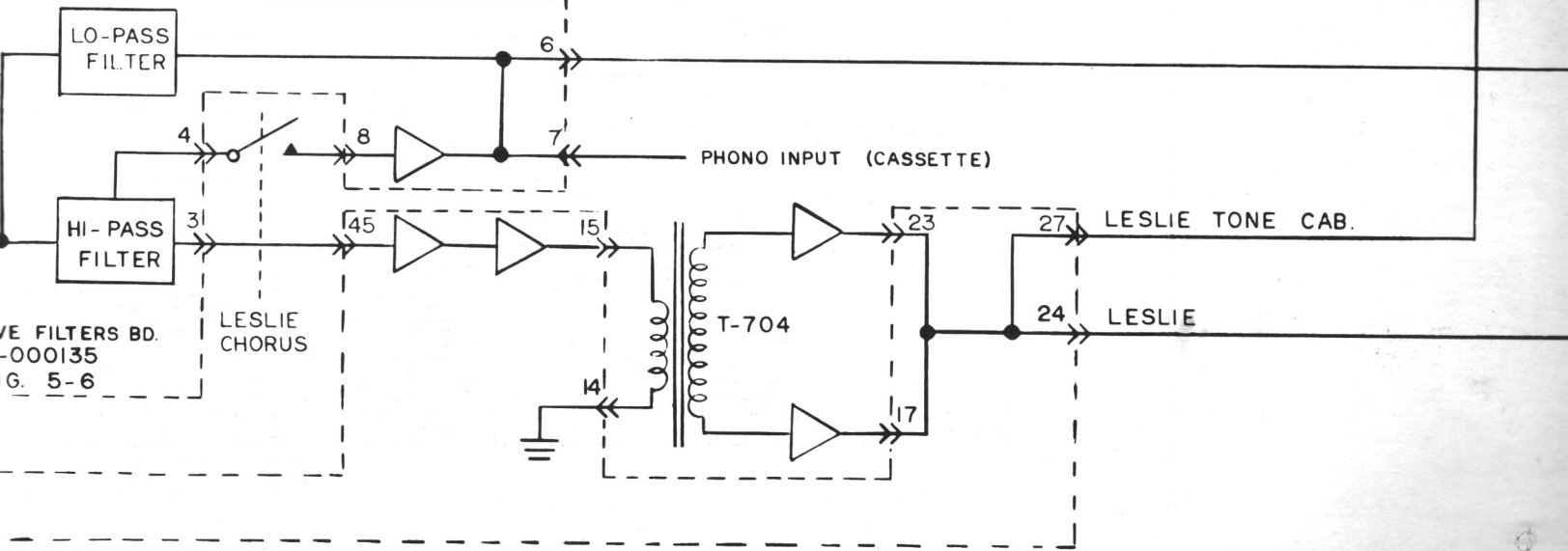
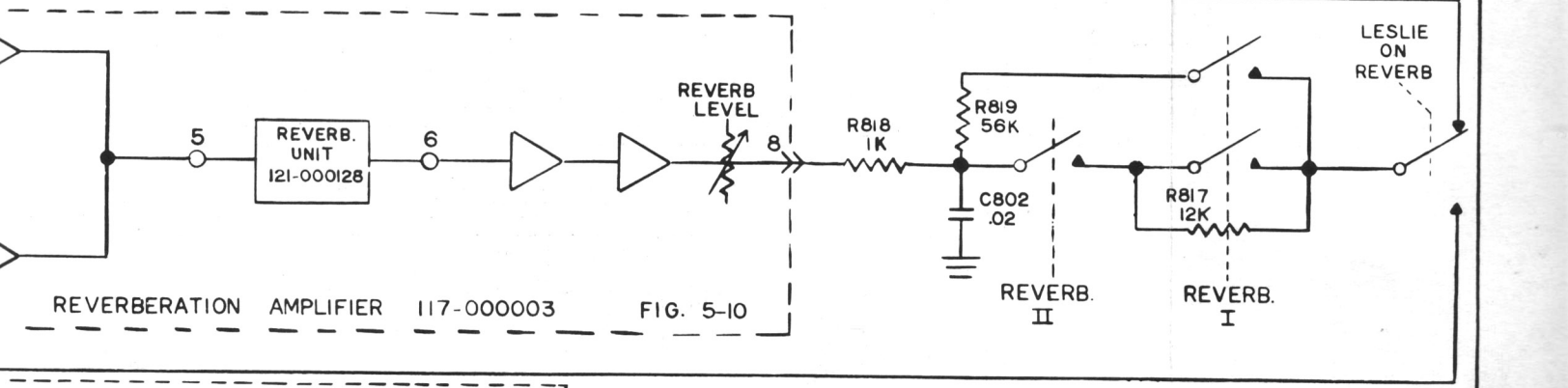
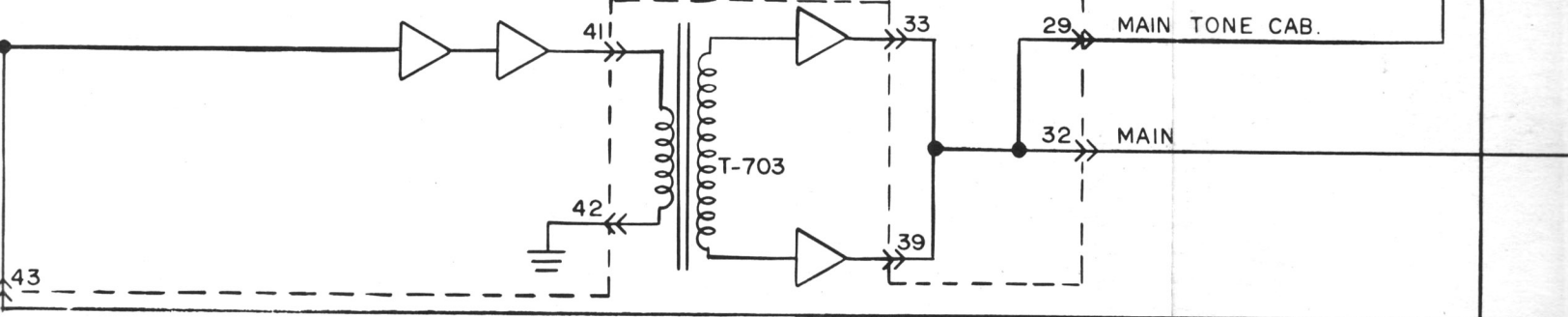

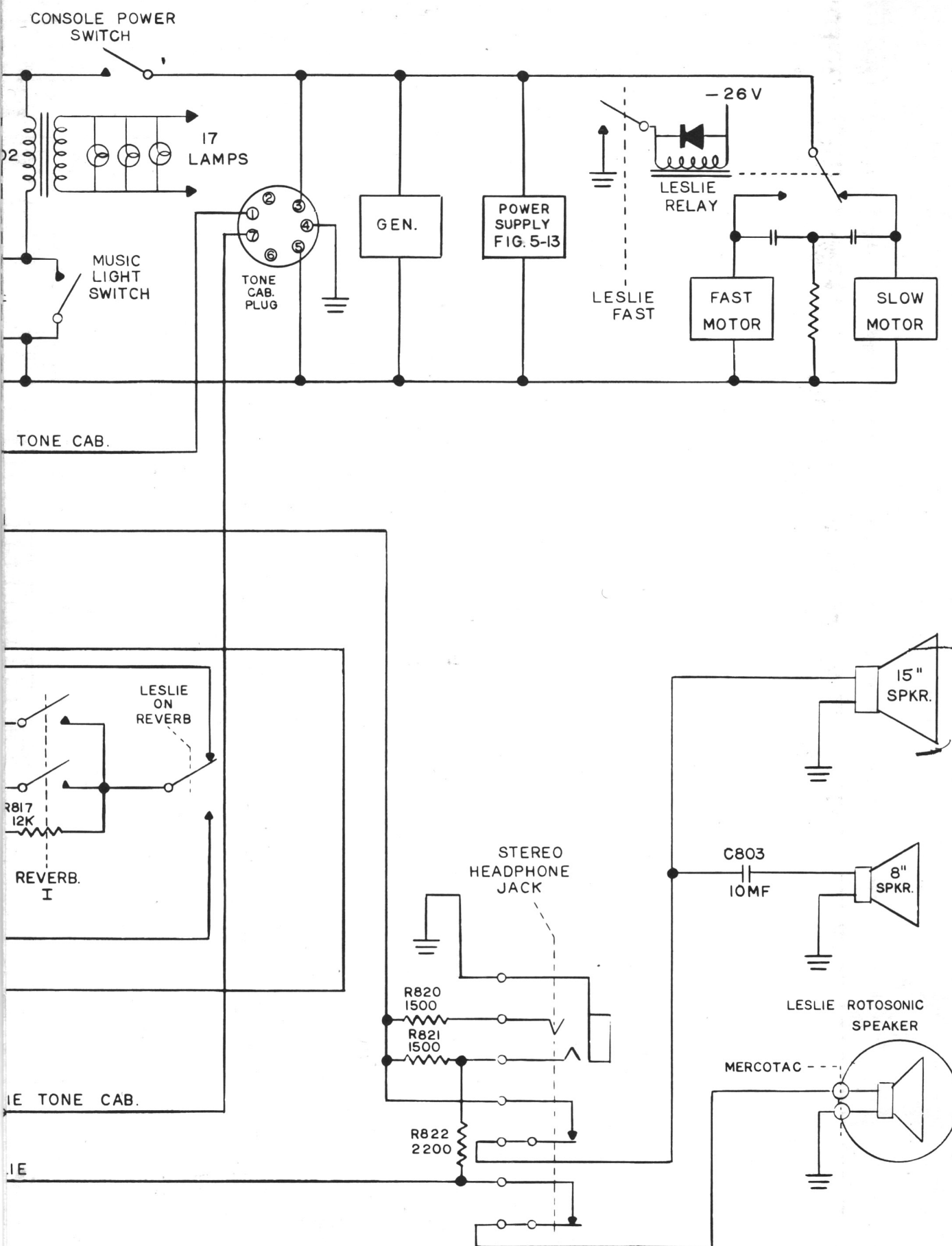

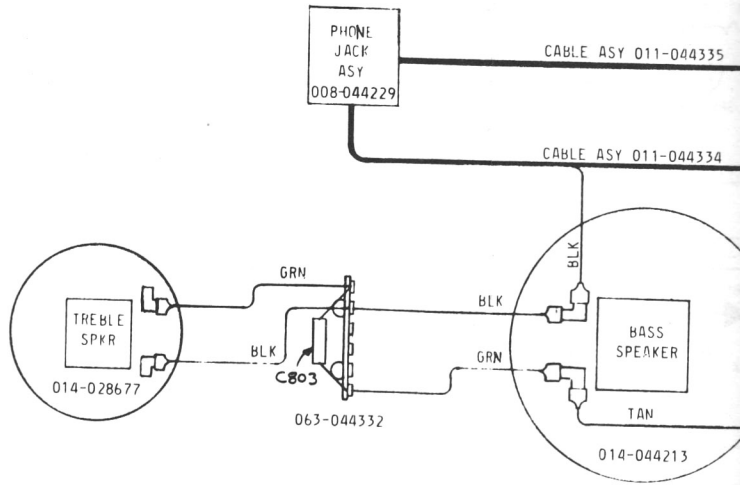

SPEAKER ASY (ROTARY TREMOLO)  
121-000124 THRU  
121-000127

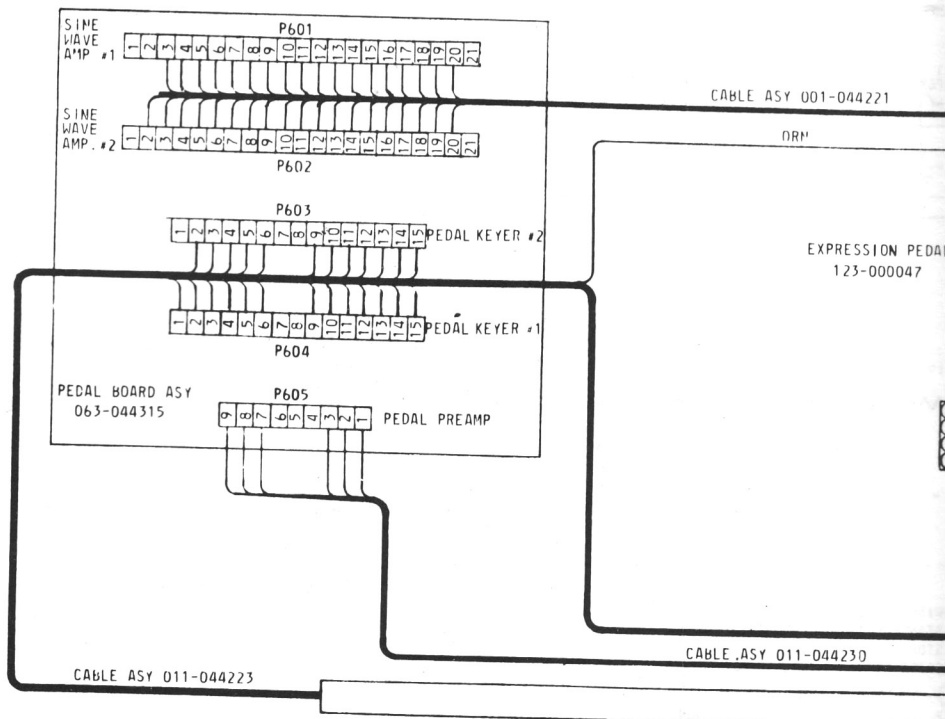

TO 011-044230  
CABLE ASY.

BLK  
FROM PUR. SUP.  
CABLE PIN #8

011-044482 (WIRE & C.N. A.Y.)

WHT/BRN

CABLE ASY 011-044335

CABLE ASY 011-044334

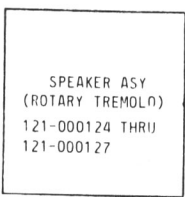
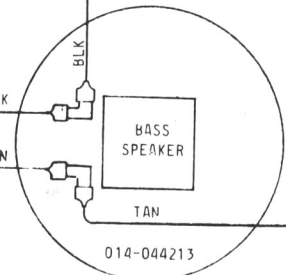

CABLE ASY 011-044329  
CABLE ASY 011-044297  
CABLE ASY 011-044221  
CABLE ASY 011-044230  
CABLE ASY 011-044338  
ORN

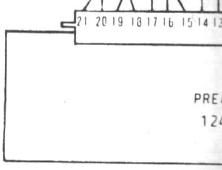
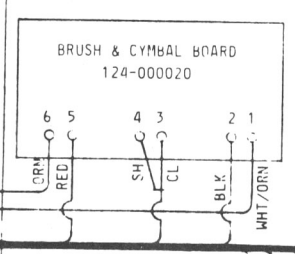
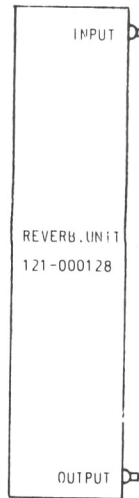

CABLE ASY 001-044221

ORN

EXPRESSION PEDAL  
123-000047

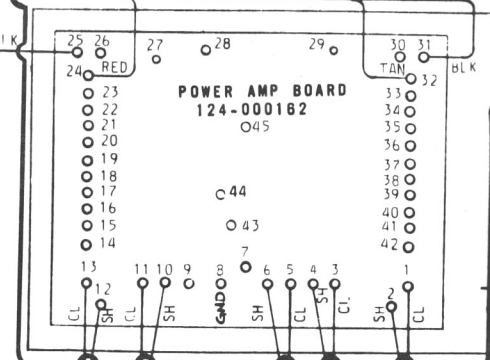
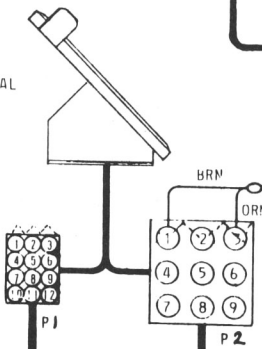

CABLE ASY 011-044297

CABLE ASY 011-044329

CABLE ASY 011-044223

RED

CABLE ASY 011-044230

PEDAL SWITCH ASY 116-000027

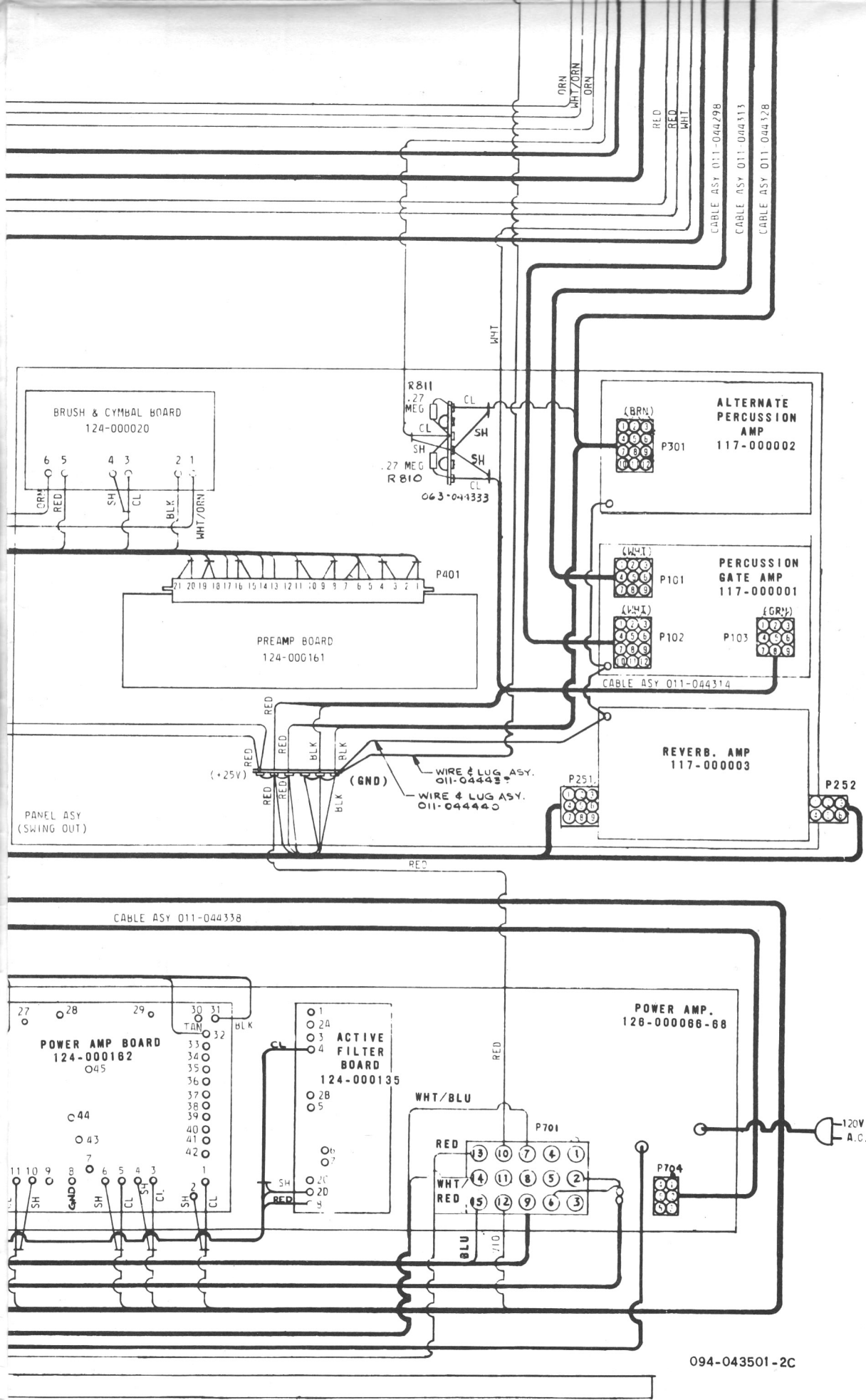

094-043501-2C

Figure



011-044345 CABLE ASY

P801

PILOT LIGHT

ON-OFF SWITCH

BRN  
BRN

BLK  
BLK

LESLIE ON REVERB

REVERB II

REVERB I

LESLIE FAST

LESLIE CHORUS

LESLIE ON LOWER

LESLIE ON UPPER

21 23 22

11

BLU

CABLE ASY 011-044338

CABLE ASY 011-044329

CABLE ASY 011-043502

68 69 85 46 45 FREQ. NO 37  
UPPER MANUAL  
WHT/RED

FREQ. NO. 91  
LOWER MANUAL

GRA YEL BLK RED GEN. MOTOR TONE GENERATOR

GRA BLU YEL

BLK

CABLE ASY 011-044297

CABLE ASY 011-044237

CABLE ASY 011-043502

TO 011-044230  
CABLE ASY.





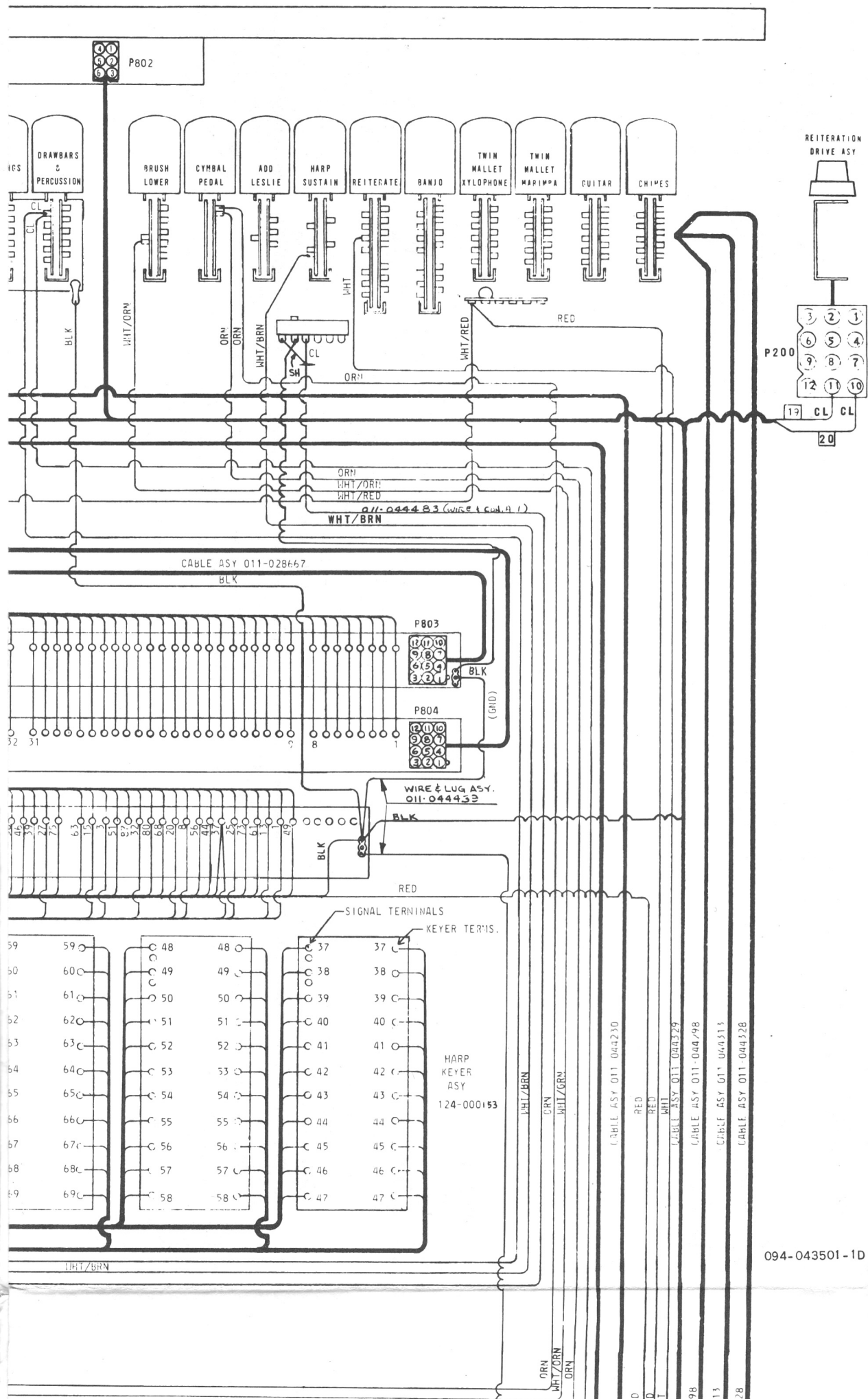

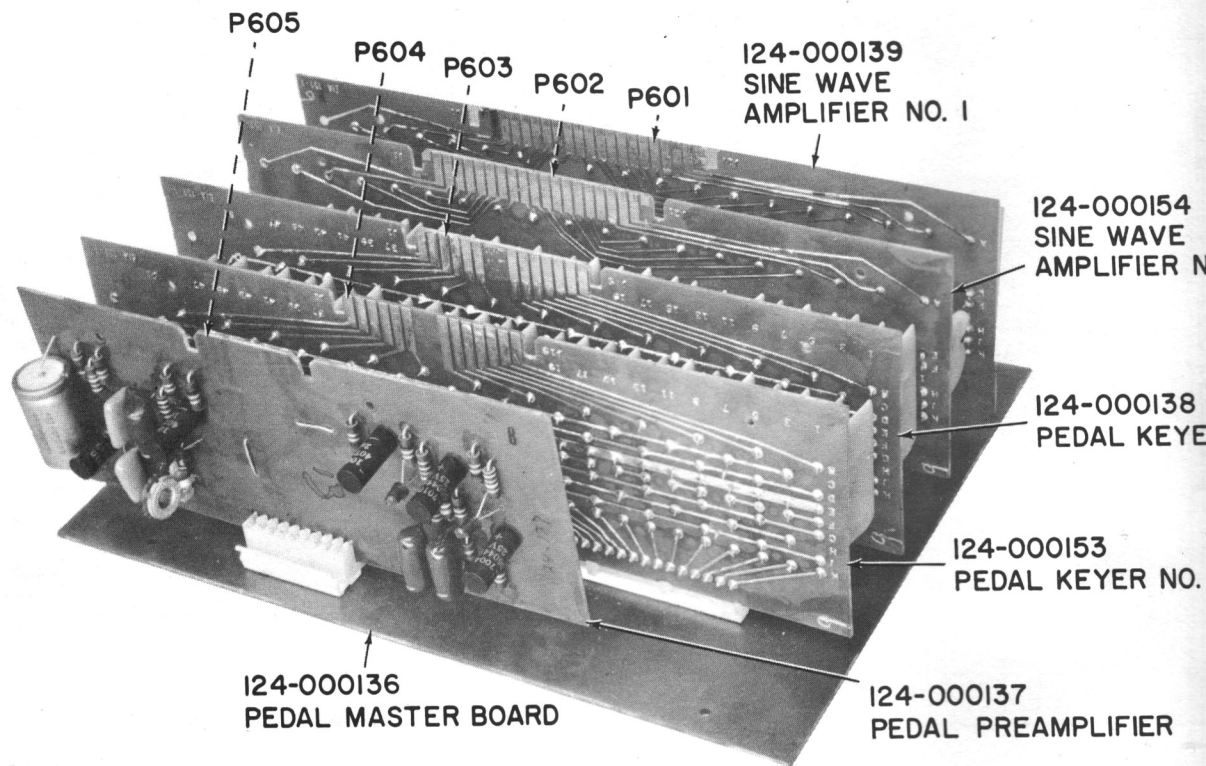
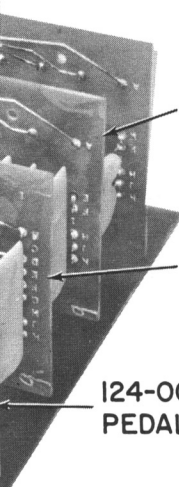

Figure 5-3. Pedal System, Board Layouts and Schematic Diagram

0139  
SINE WAVE  
AMPLIFIER NO. 1



124-000154  
SINE WAVE  
AMPLIFIER NO. 2

124-000138  
PEDAL KEYSER NO. 1

124-000153  
PEDAL KEYSER NO. 2

124-000137  
PEDAL PREAMPLIFIER

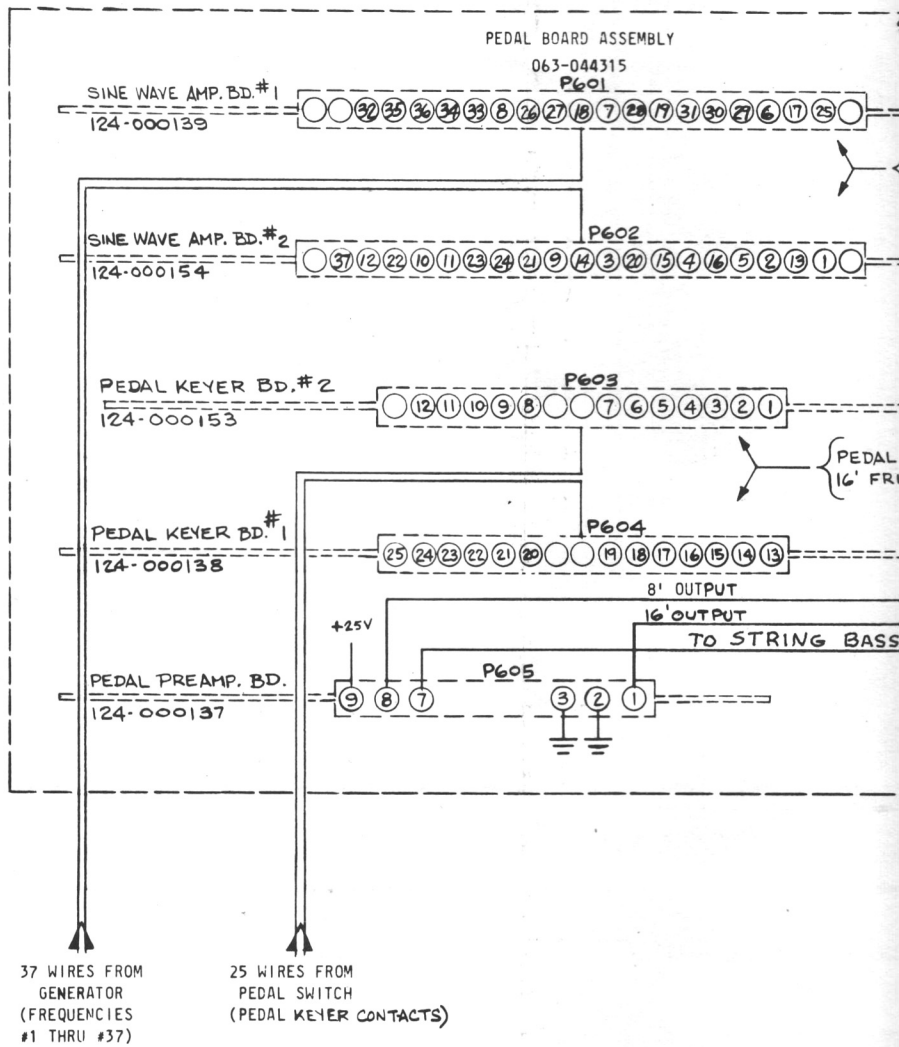



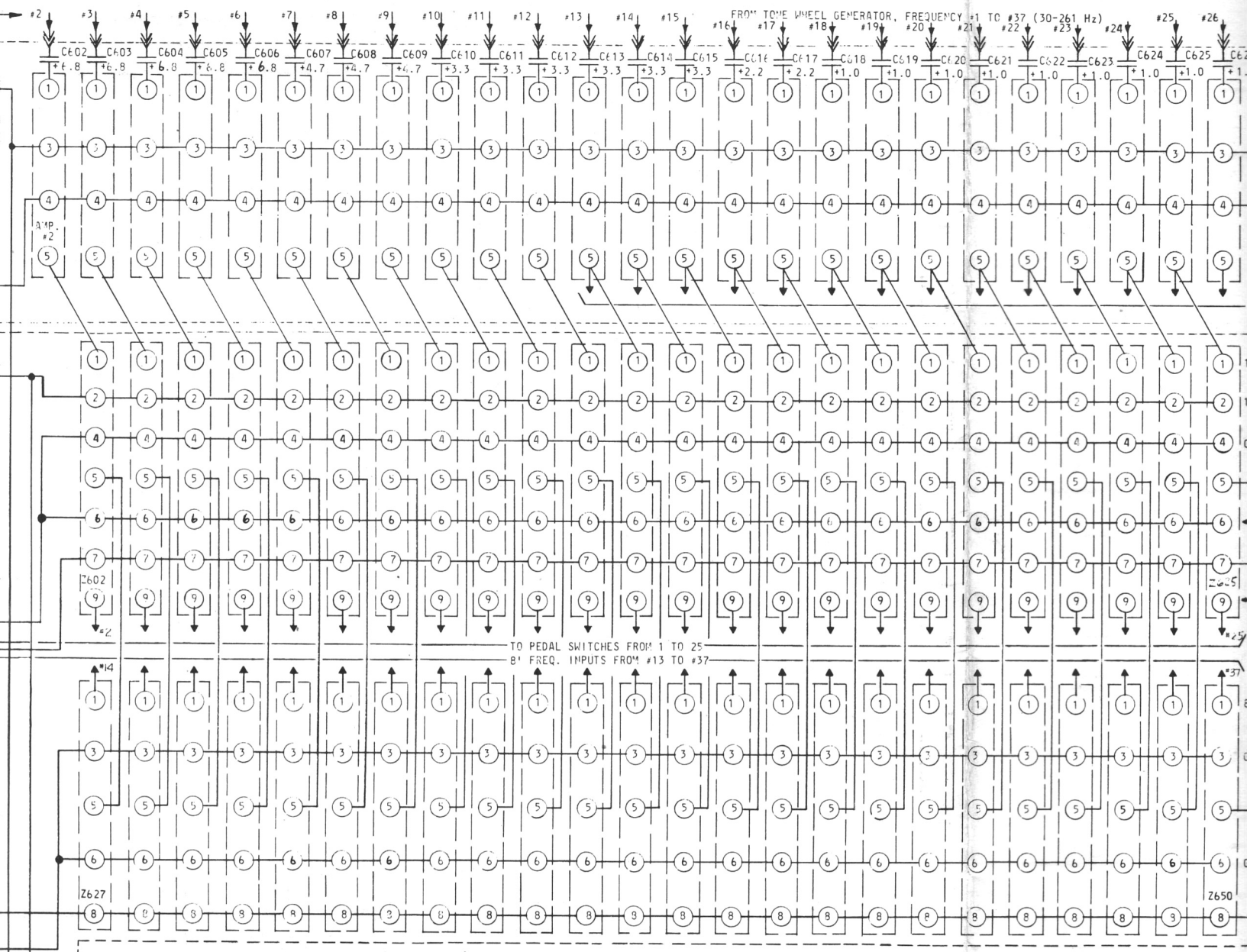

TO PEDAL SWITCHES FROM 1 TO 25  
8' FREQ. INPUTS FROM #13 TO #37

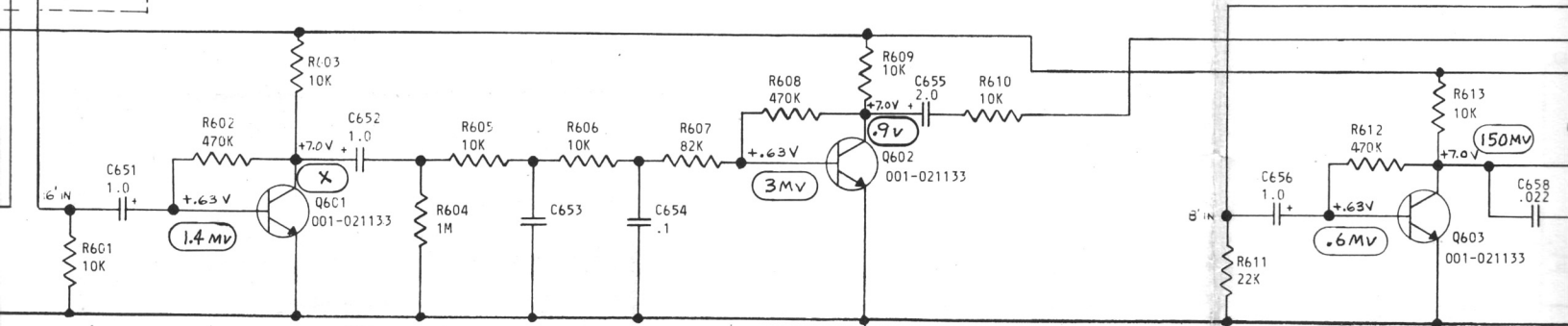

PRINTED WIRING BOARD ASY. 124-00137 (PEDAL PREAMPLIFIER)

X - METER LOADING -  
OSCILLATION OCCURS

094-044401

D.  
ED NETWORK.  
IGHT OF CONNECTOR.  
PRESSED

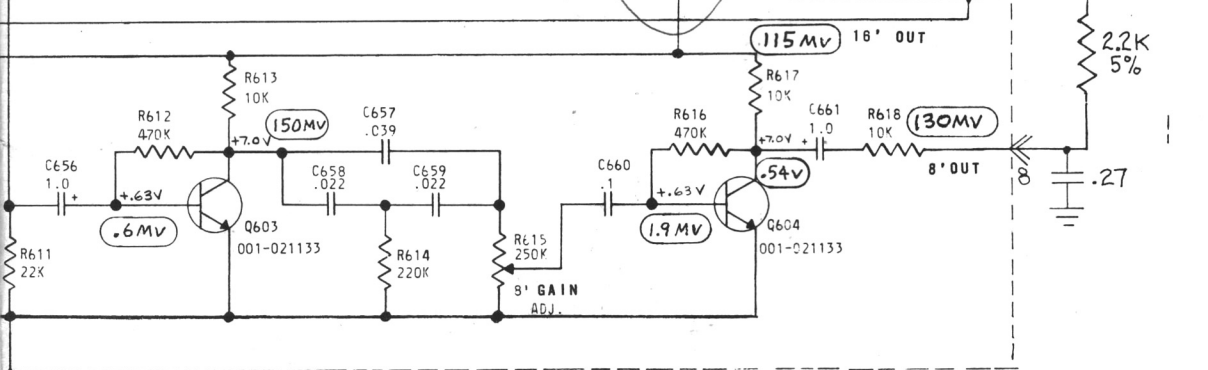
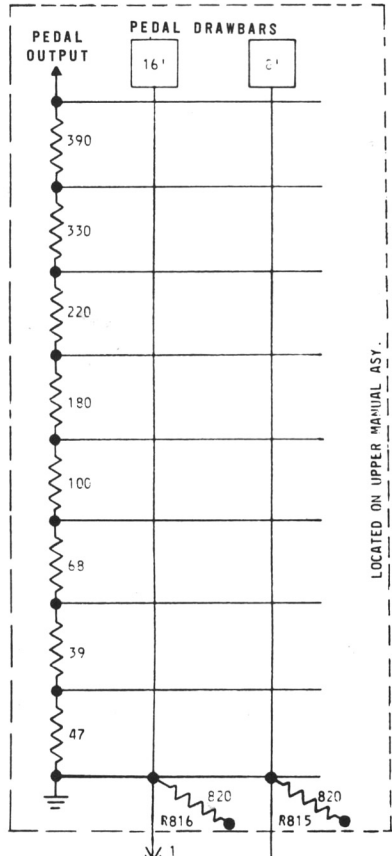
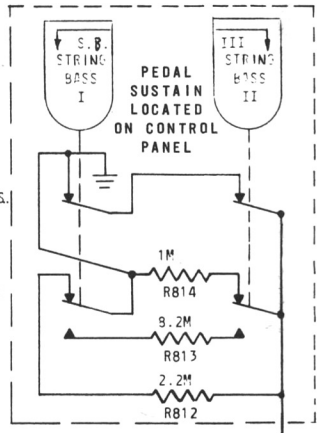
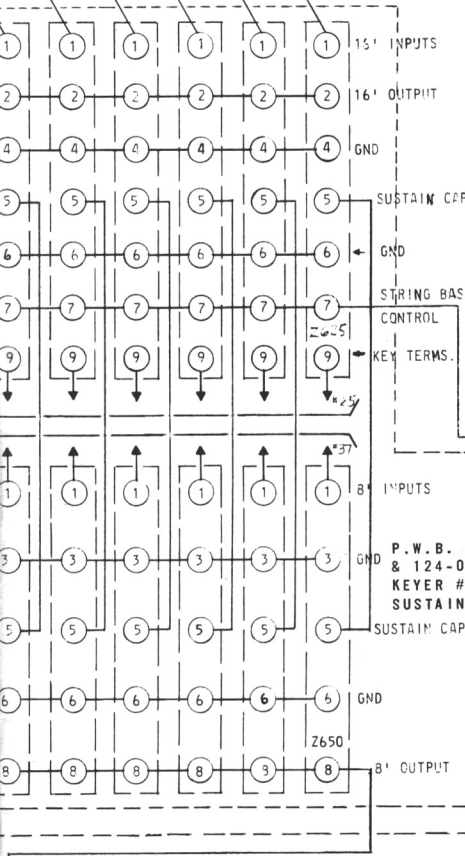
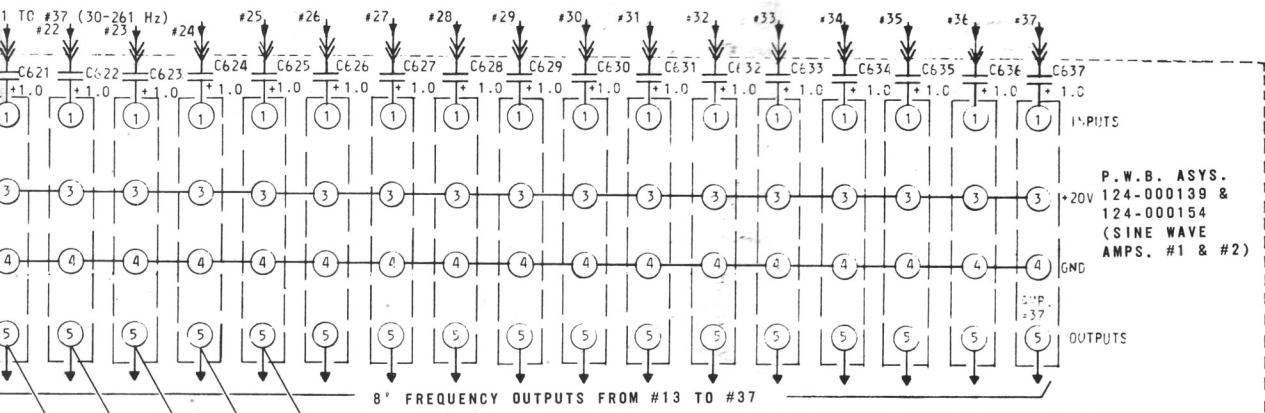

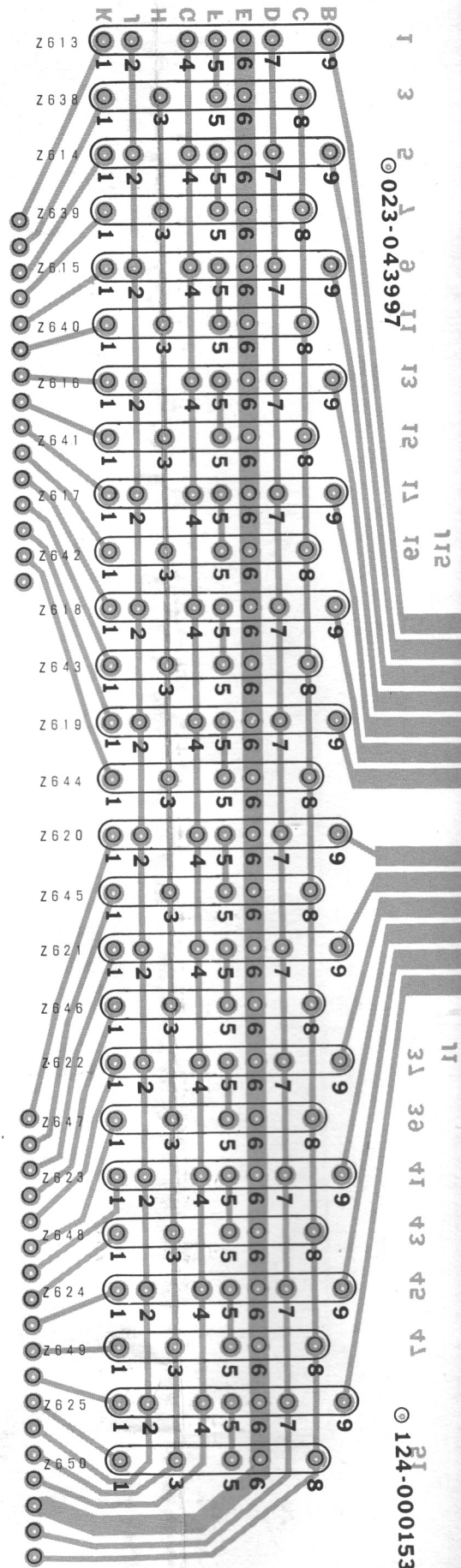
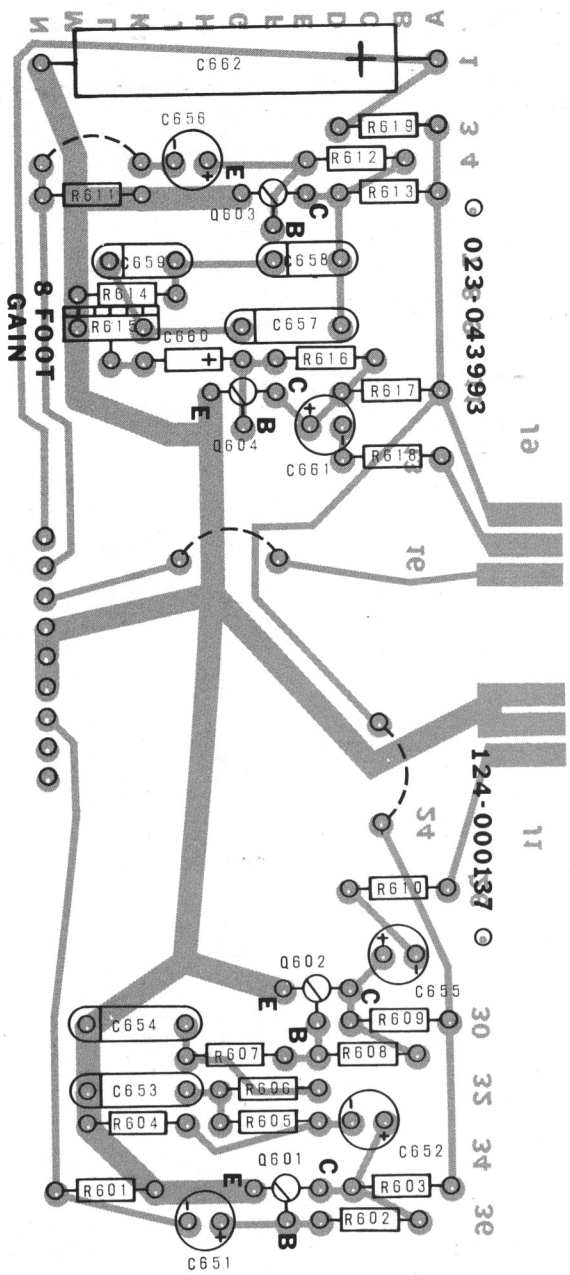

1 3 2 023-043997

31 30 41 43 42 41

© 124-000153





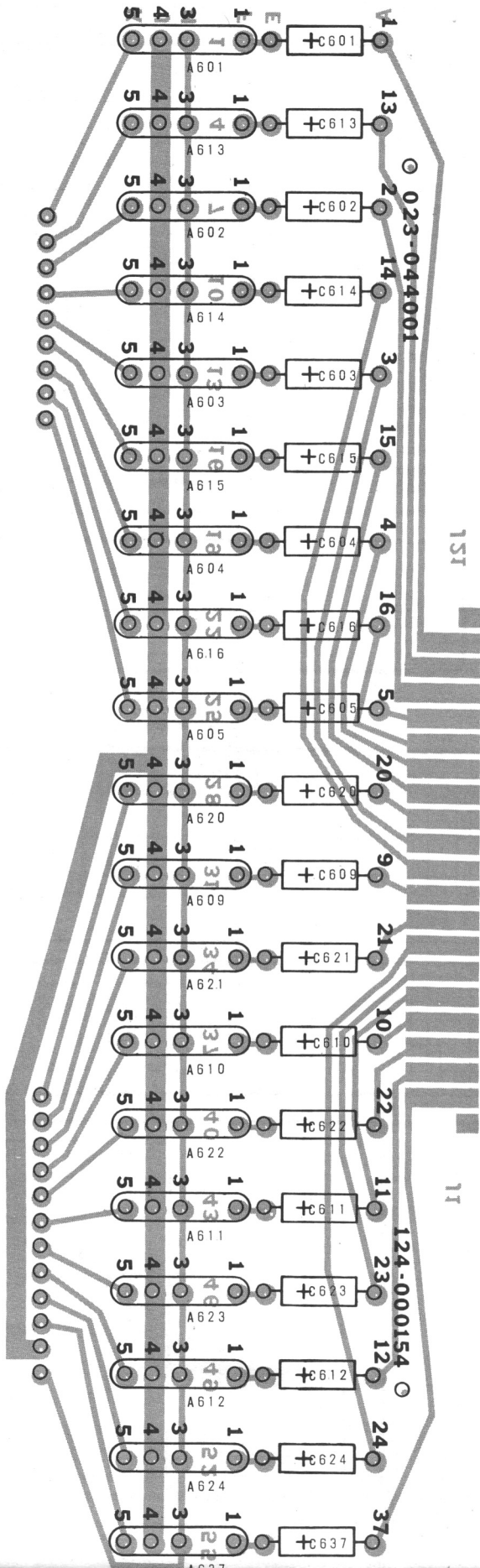
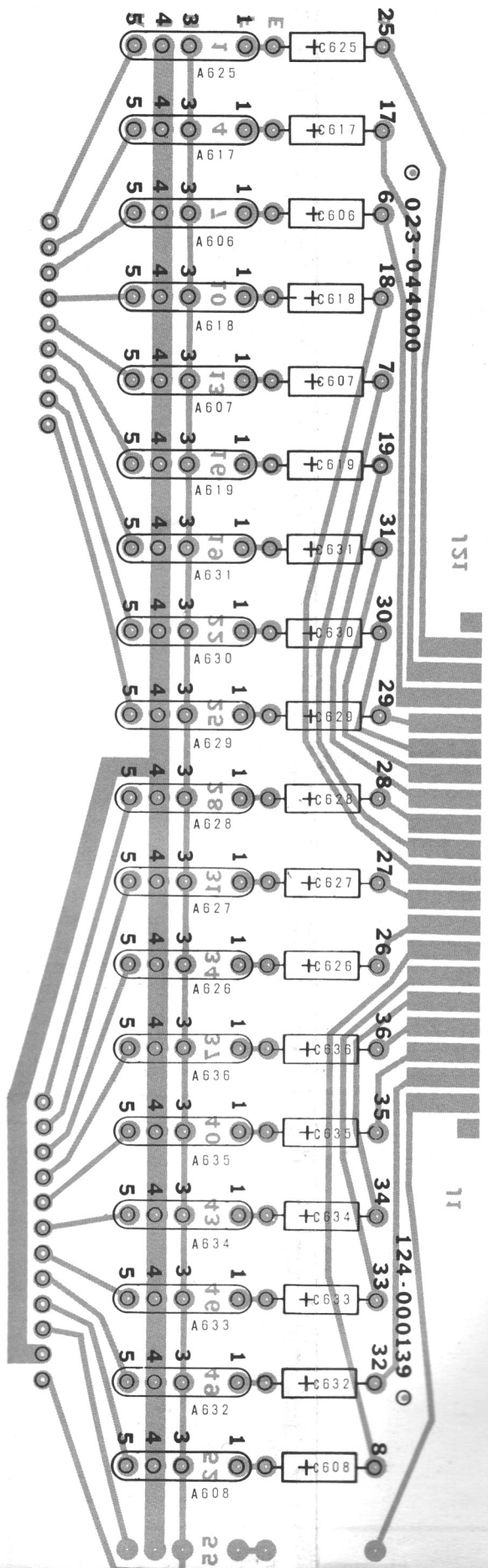

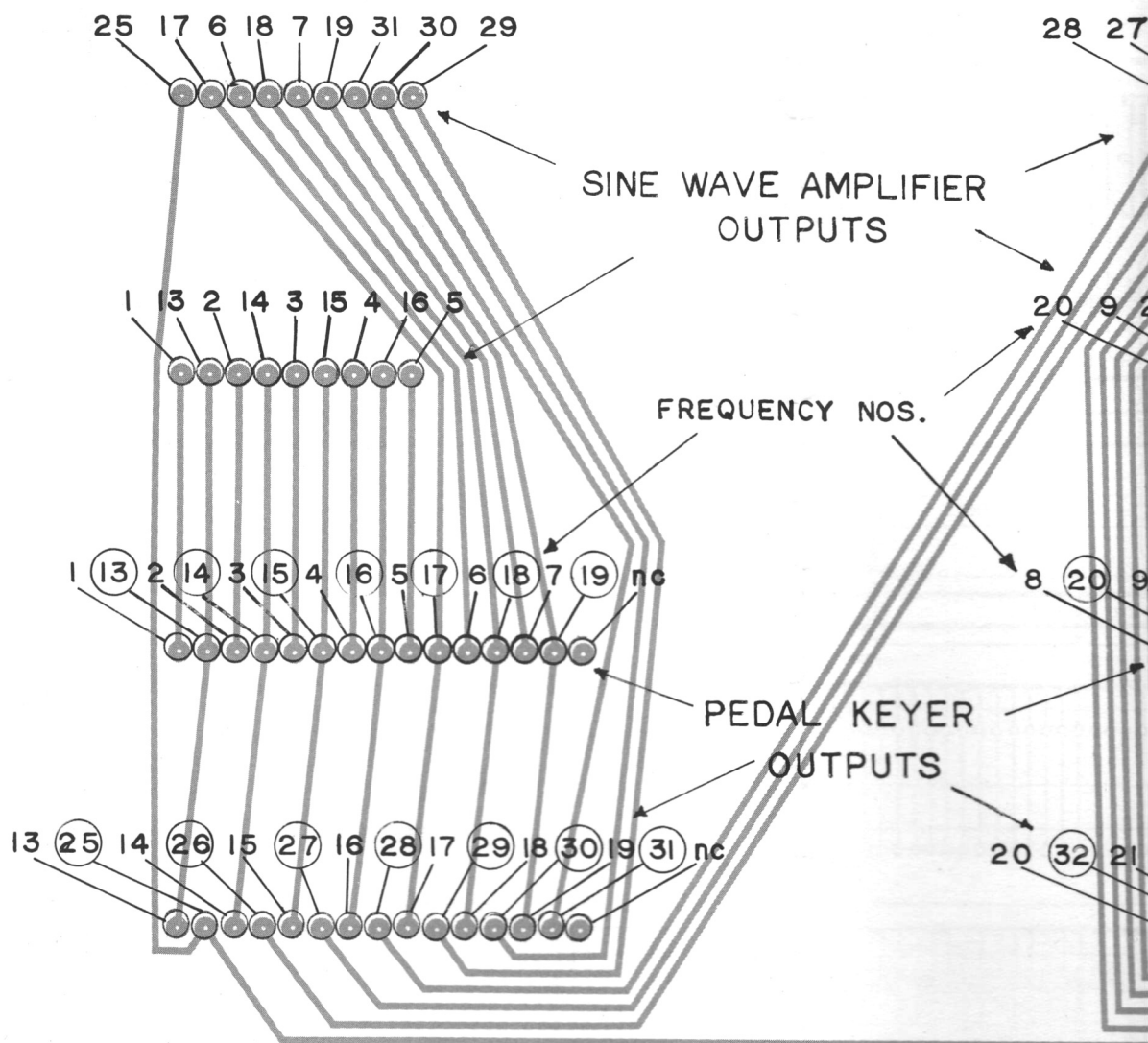
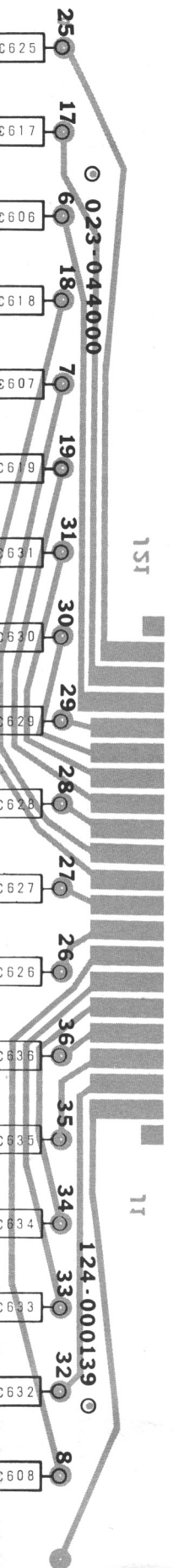

- INDICATES 8' KEYS
- x OUTPUT OF 16' KEYS
- xx TO STRING BASS II SWITCH
- xxx OUTPUT OF 8' KEYS

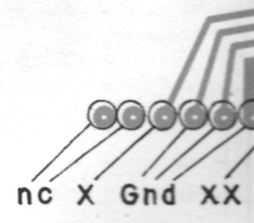

NOTE: COPPER PATTERN AS VIEWED FROM ETCHED SIDE OF BOARD

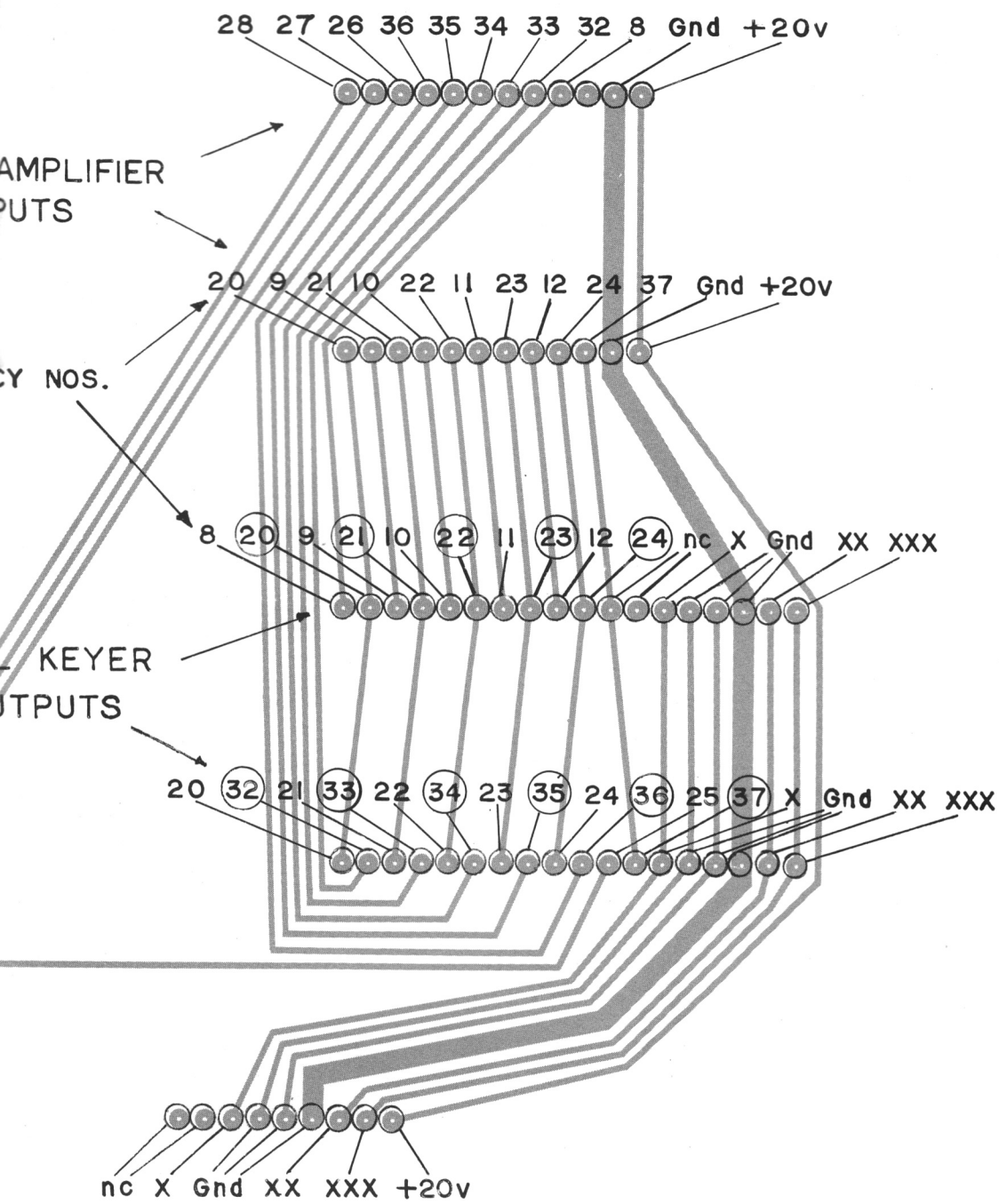

ERN AS VIEWED  
SIDE OF BOARD

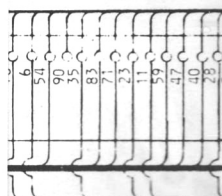
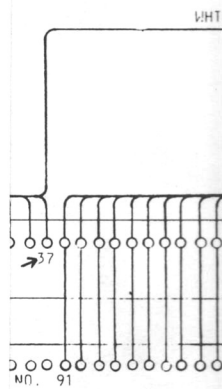
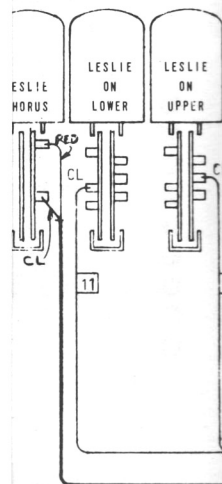

BLK

AS# 011-044237

AS# 011-043502

TO 011-044230  
CABLE ASY.

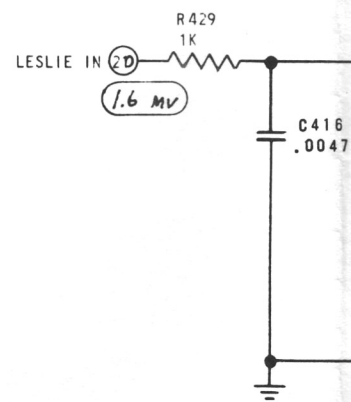
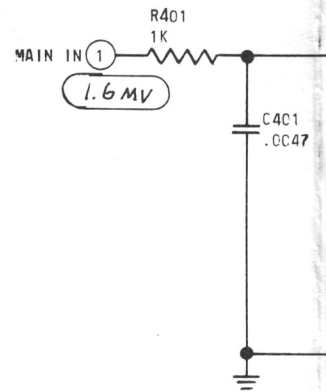
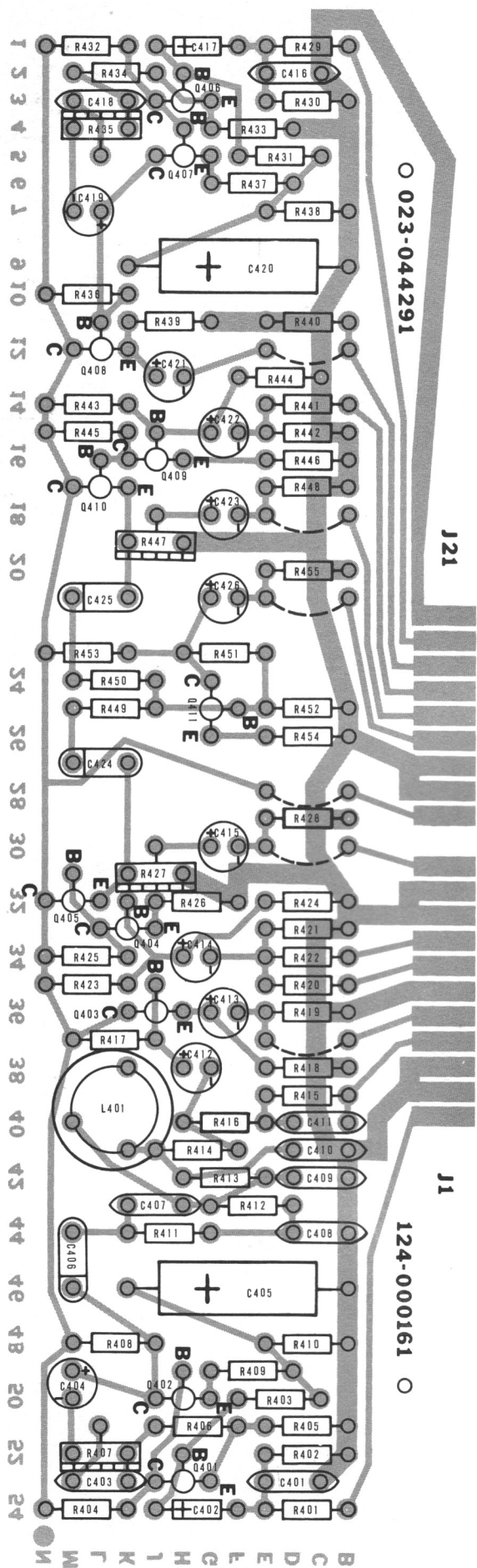

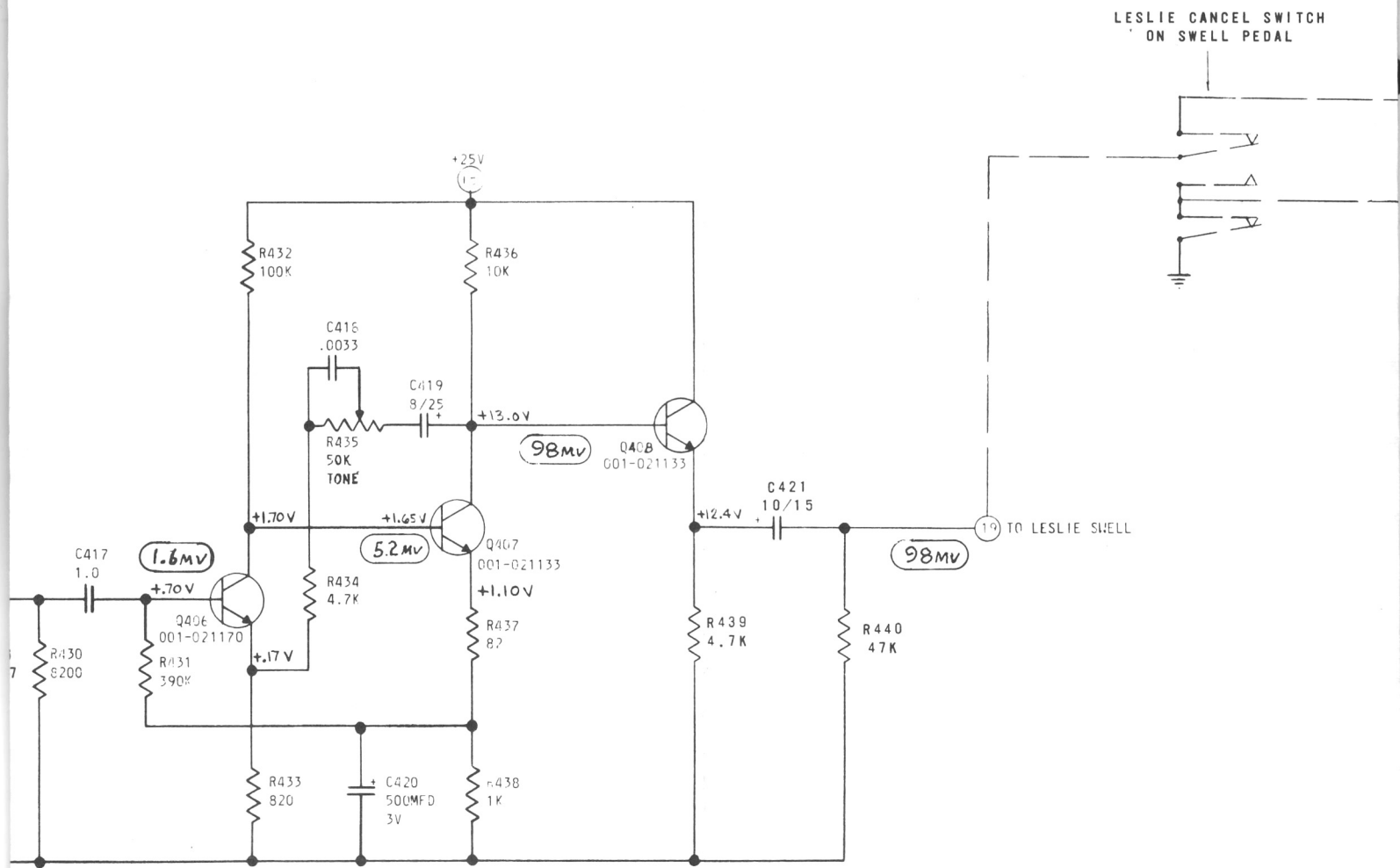
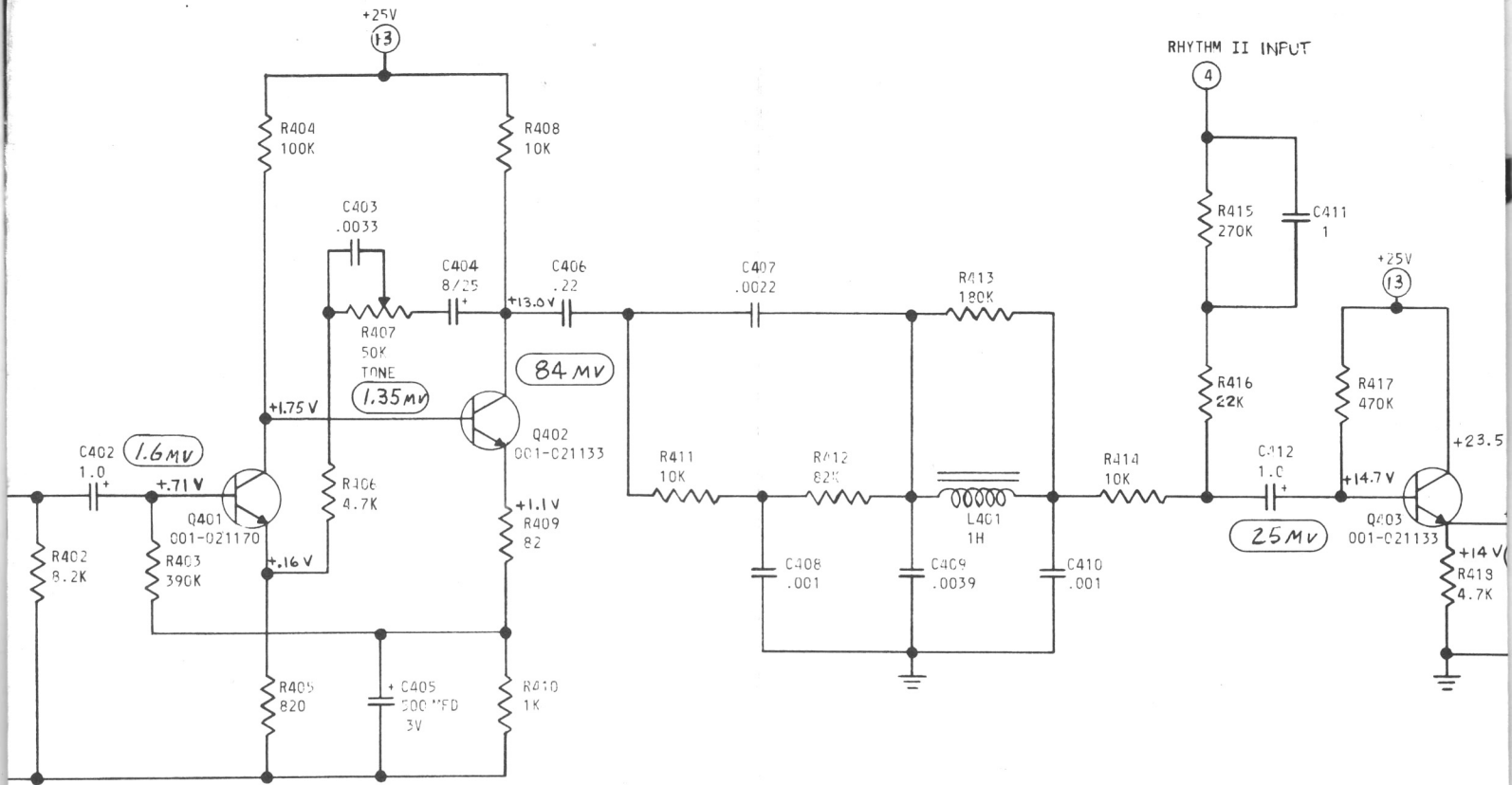



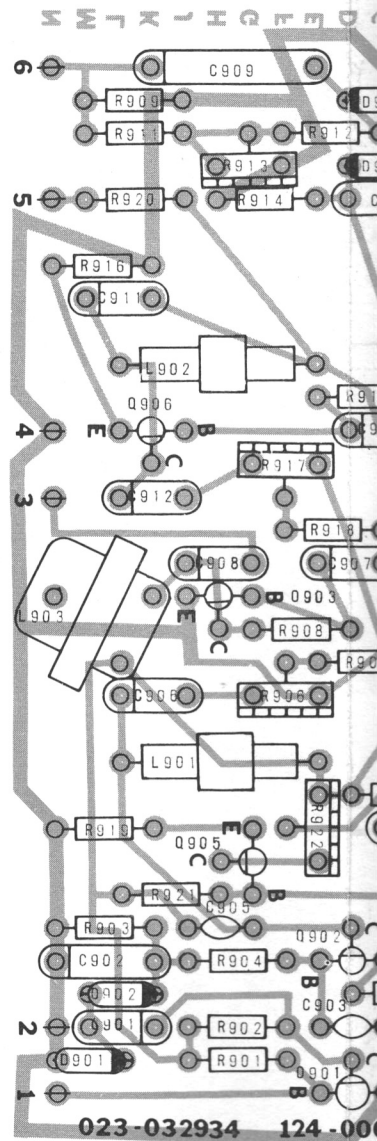
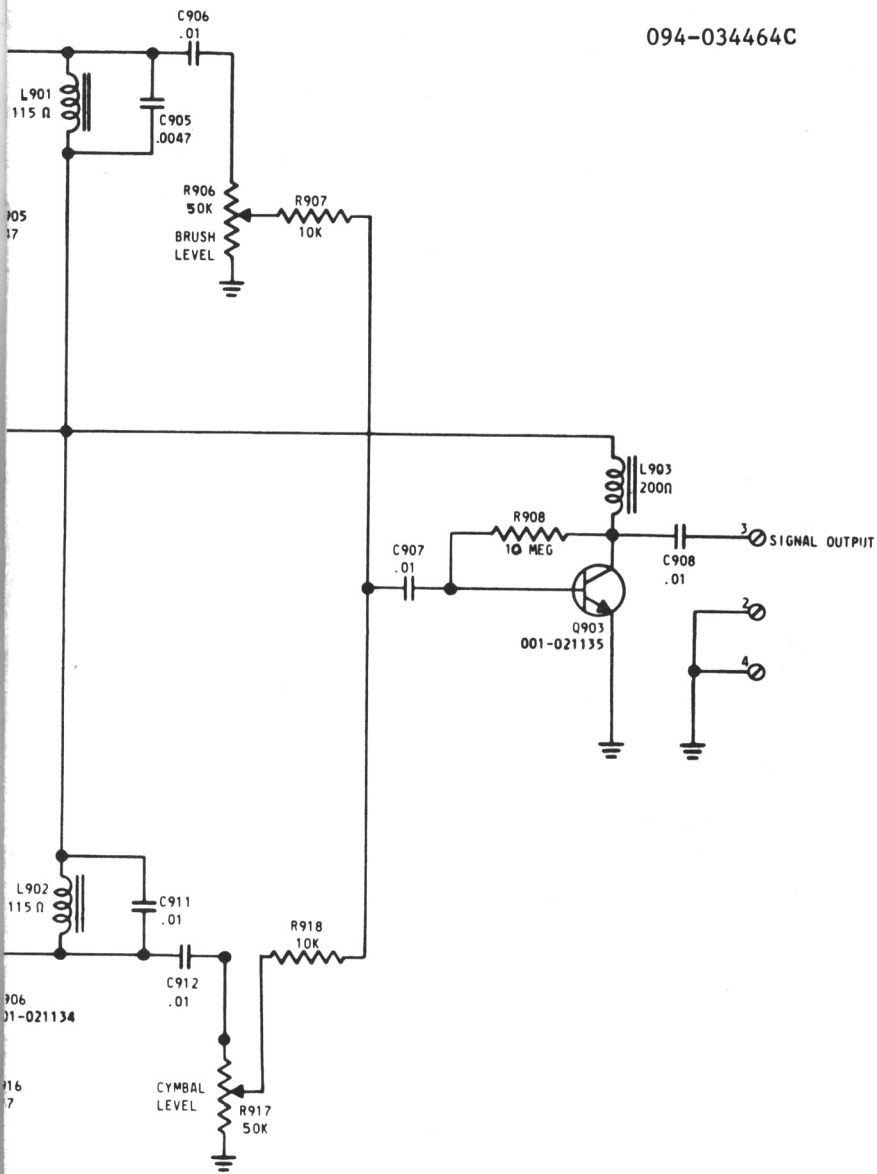

Figure 5-5. Cymbal/Brush Generator, Layout and Schematic Diagram





094-034464C



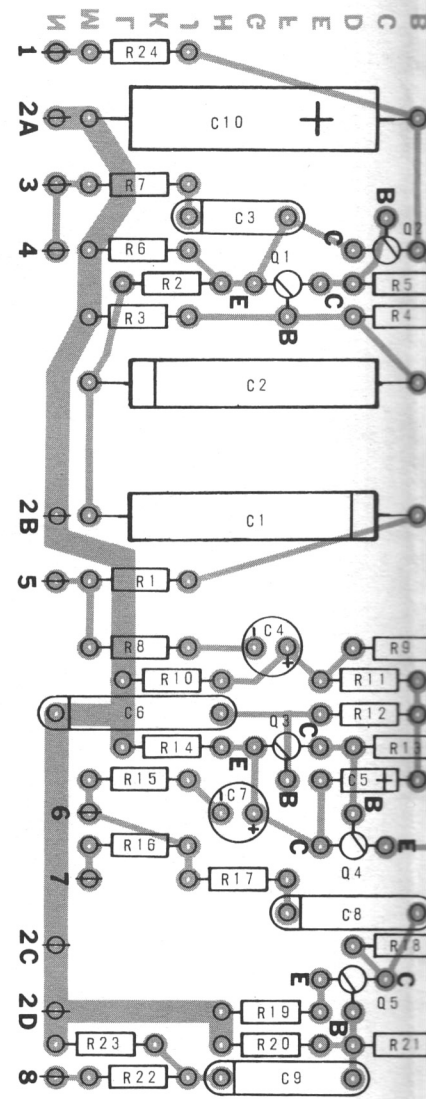

1  
 3  
 2060238043978  
 12 11 1a 1a ST 124-090135 5a 3135

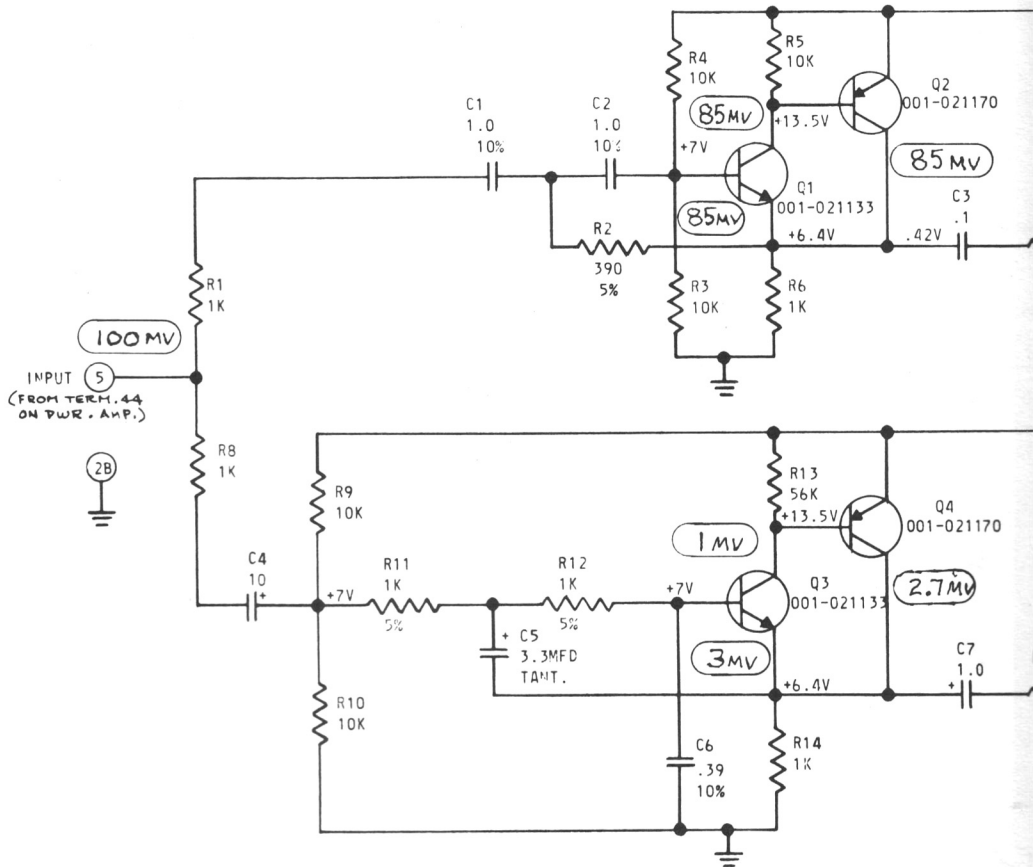

NOTES:

1. UNLESS OTHERWISE SPECIFIED:
  - a. ALL RESISTANCE VALUES IN OHMS 10%.
  - b. ALL RESISTORS 1/2 WATT.
  - c. ALL CAPACITORS WITH DECIMAL VALUES IN MFD.
2. (7) DENOTES NUMBERED PINS ON P.W. BOARD.
3. (O) RMS VOLTAGES TAKEN WITH DB#4 KEY 25 DEPRESSED AND LESLIE ON UPPER
4. (□) STEP 3 PLUS LESLIE CHORUS

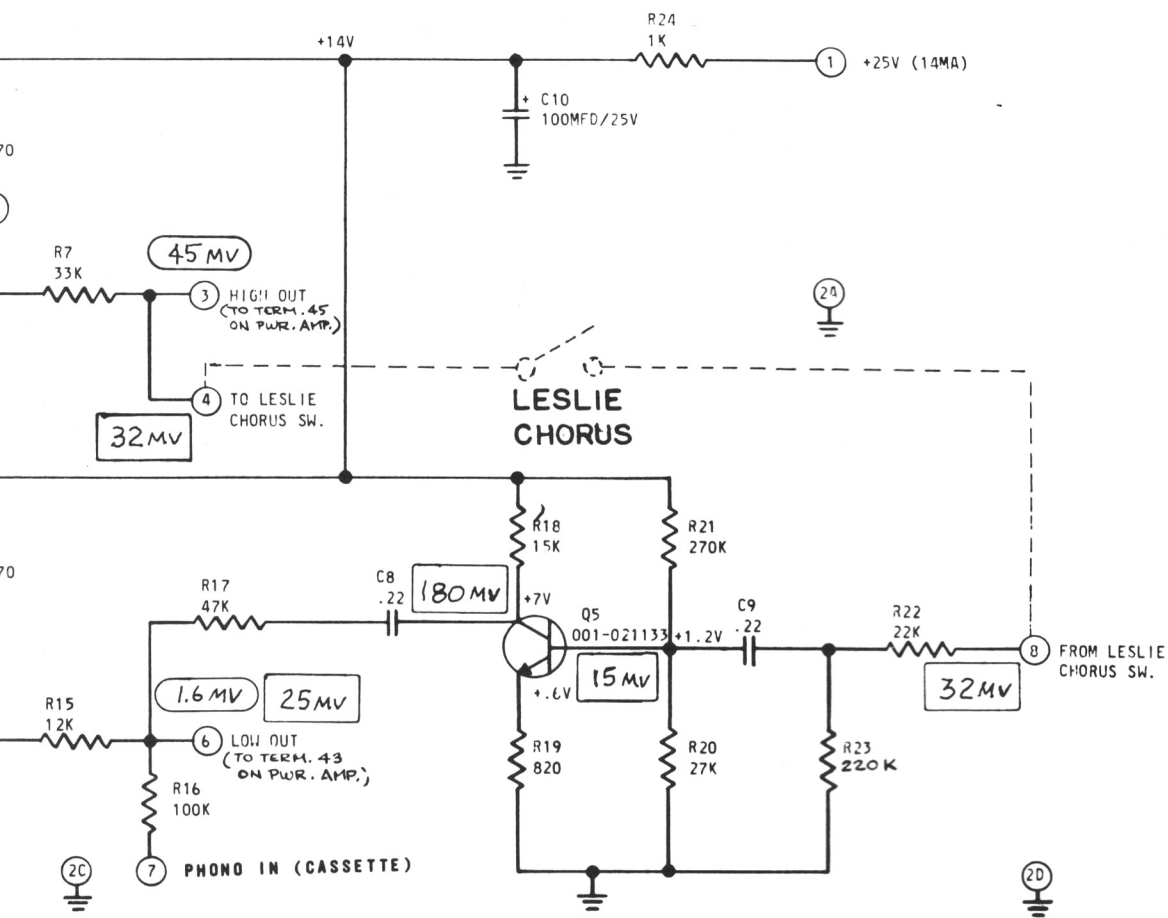

094-044246B

Figure 5-6. Active Filters, Layout and Schematic Diagram

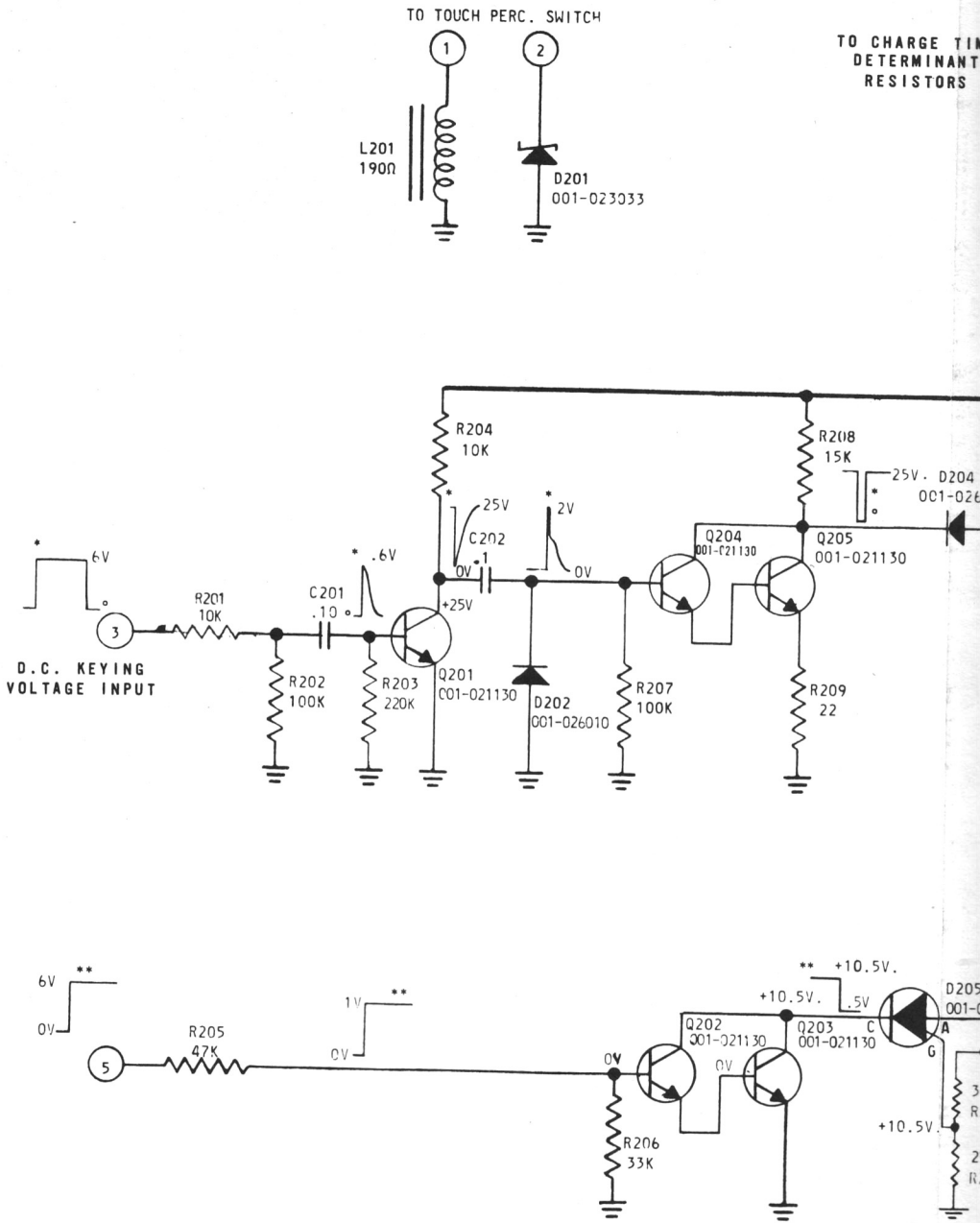

**NOTES:**

1. (5) SYMBOL DENOTES TERMINAL IN PLUG
2. UNLESS OTHERWISE SPECIFIED:  
 ALL RESISTORS ARE IN OHMS,  $\pm 10\%$ , 1/2 WATT;  
 ALL CAPACITORS ARE IN MICROFARADS.  
 \* PULSES DURING PERCUSSION MODE  
 \*\* PULSES DURING REITERATION MODE

Figure 5-7. Percussion and Reiteration Driver, Layout and Schematic Diagram

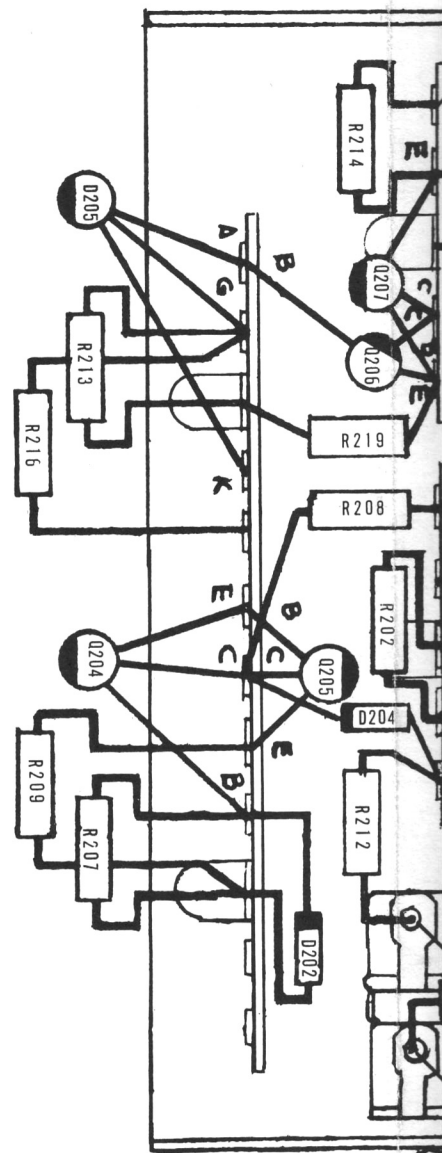
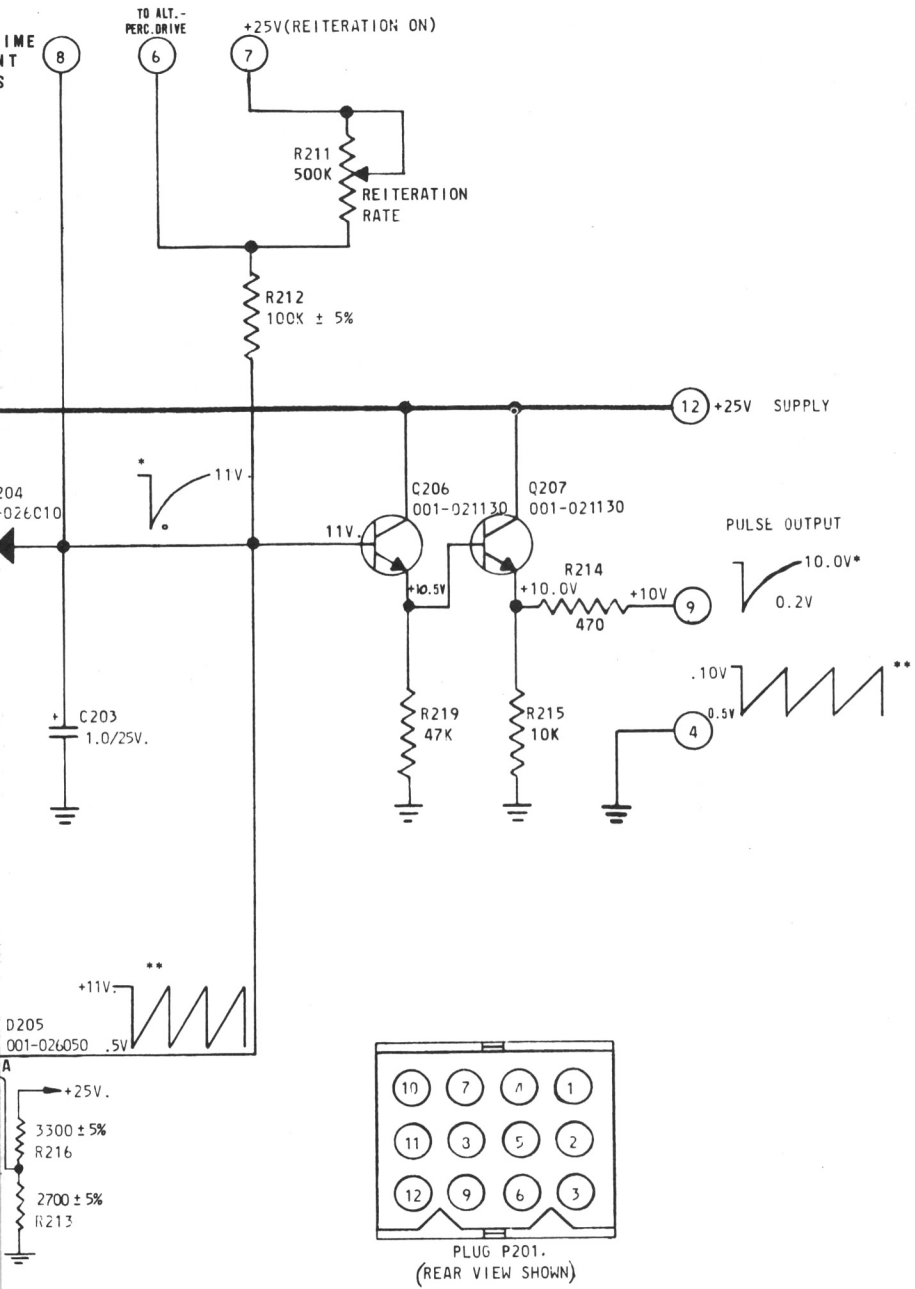

094-034460A

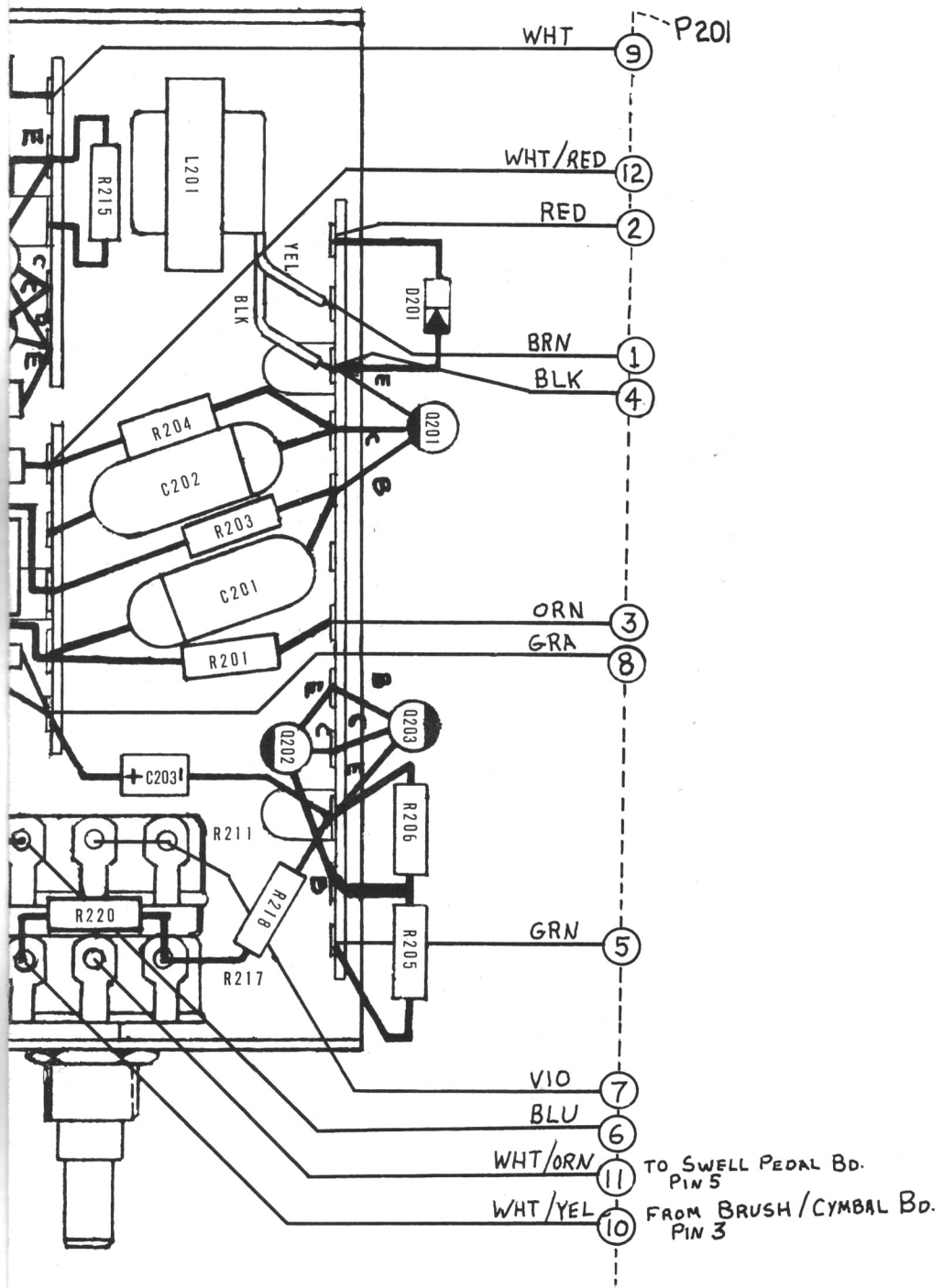

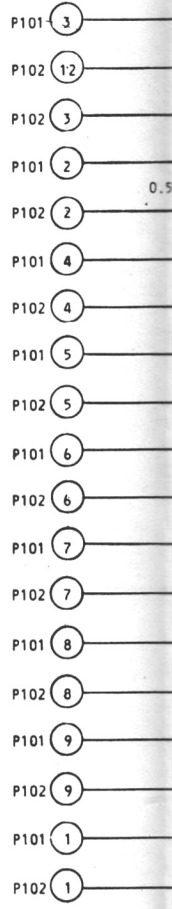
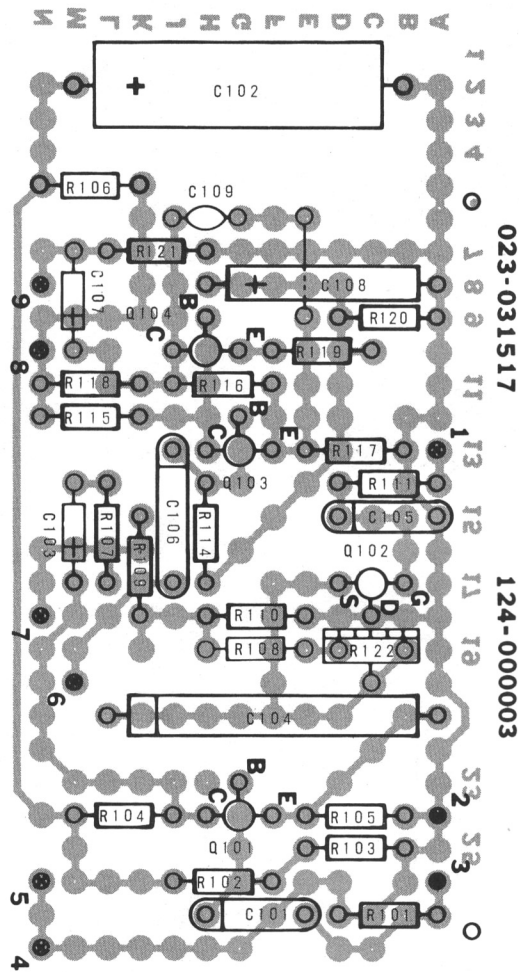

SIGNAL INPUT

D.C. DRIVE INPUT

- NOTES:
1. (3) SYMBOL DENOTES TERMINAL IN PL
  2. (⊗) SYMBOL DENOTES TERMINAL ON PR
  3. UNLESS OTHERWISE SPECIFIED:  
ALL RESISTORS ARE IN OHMS, ±  
ALL CAPACITORS ARE IN MICROFA
  4. \*AC VOLTAGES DEPEND ON R<sub>DS</sub> OF Q 102



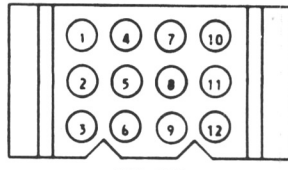
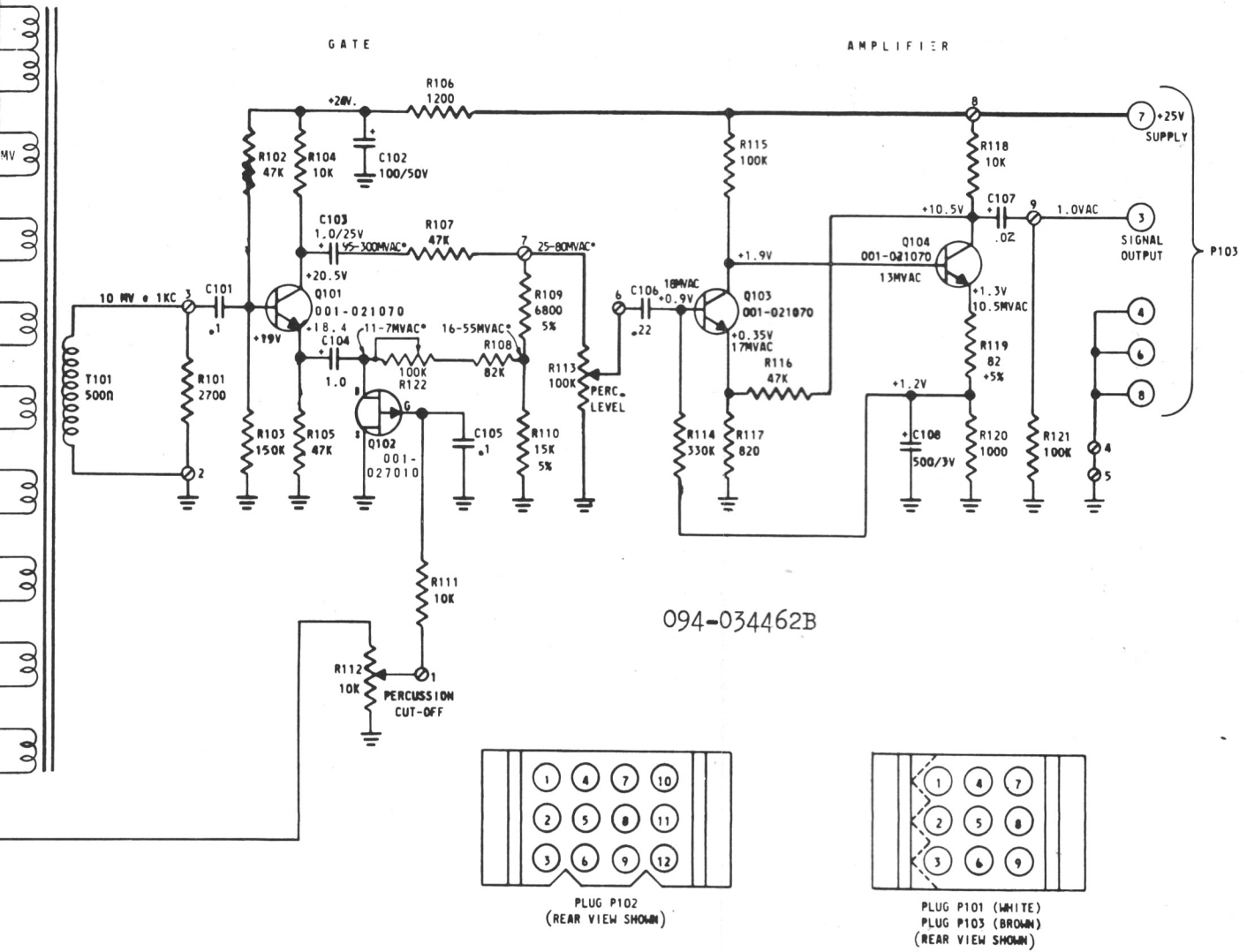

PLUG P102  
(REAR VIEW SHOWN)

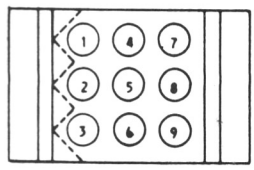

PLUG P101 (WHITE)  
PLUG P103 (BROWN)  
(REAR VIEW SHOWN)

UG.  
PRINTED WIRING BOARD.  
10%, 1/2 WATT;  
GRADS  
F.E.T.

Figure 5-8. Percussion Gate Amplifier, Board Layout and Schematic Diagram

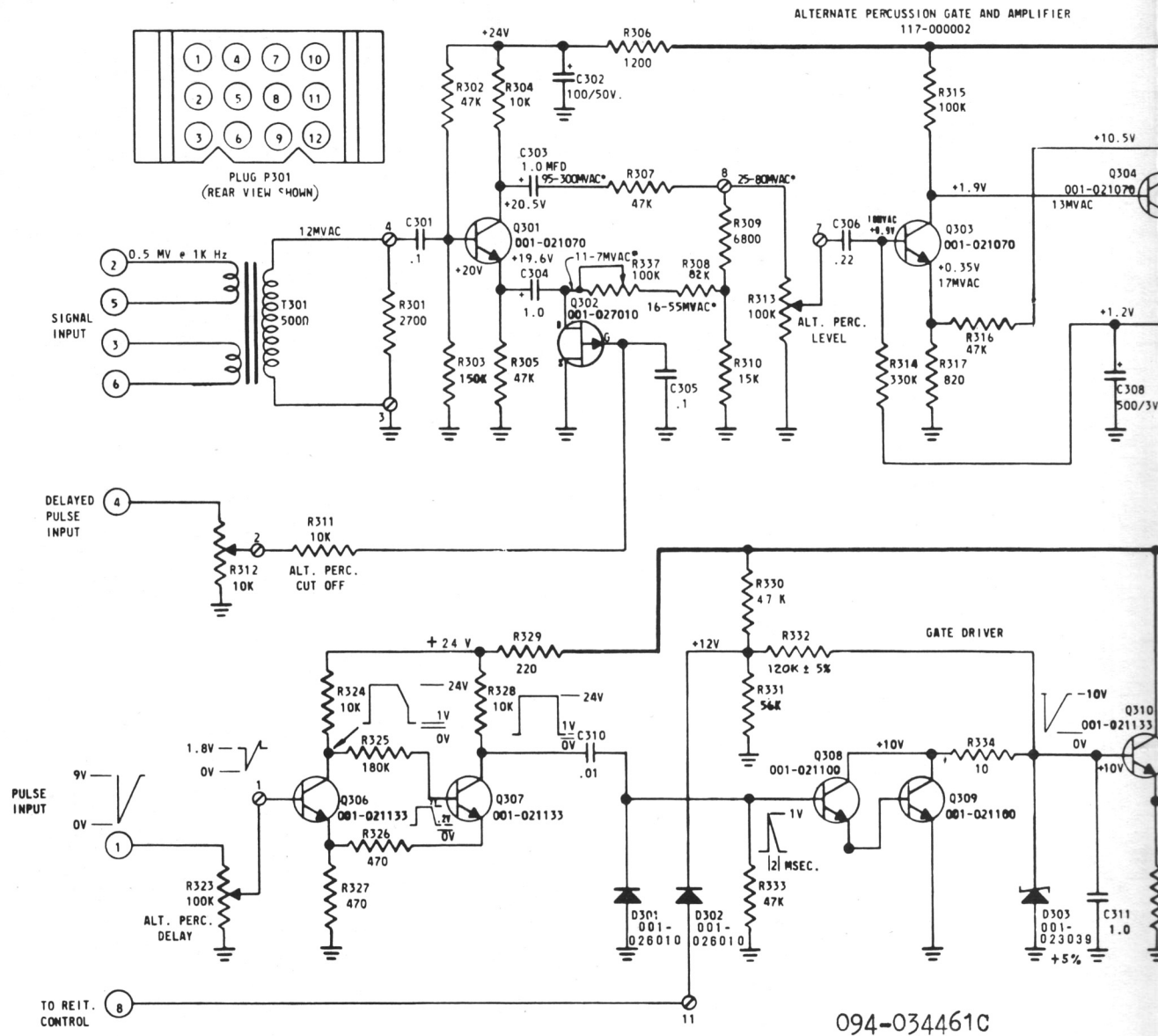

NOTES:

1. (B) SYMBOL DENOTES TERMINAL IN PLUG.
2. (O) SYMBOL DENOTES TERMINAL ON PRINTED WIRING BOARD.
3. UNLESS OTHERWISE SPECIFIED:  
ALL RESISTORS ARE IN OHMS,  $\pm 10\%$ , 1/2 WATT;  
ALL CAPACITORS ARE IN MICROFARADS
4. \* A.C. VOLTAGES DEPEND ON R<sub>1</sub> OF Q302, F.E.T.

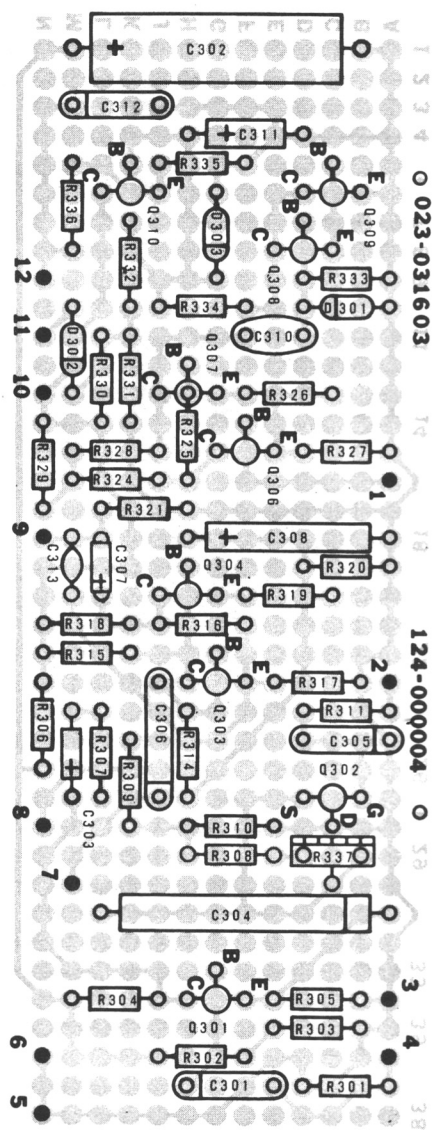
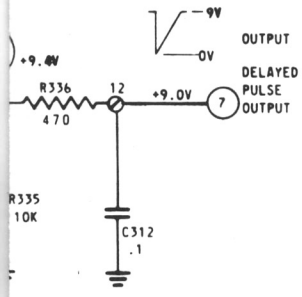
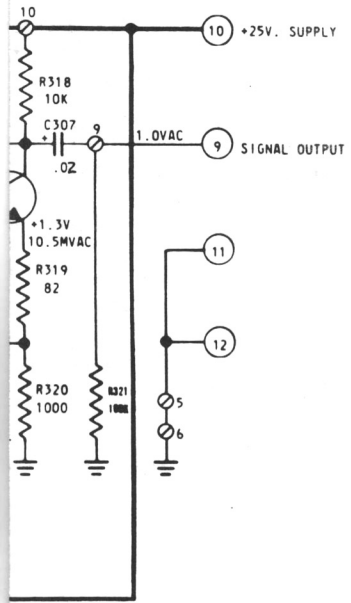

124-000004

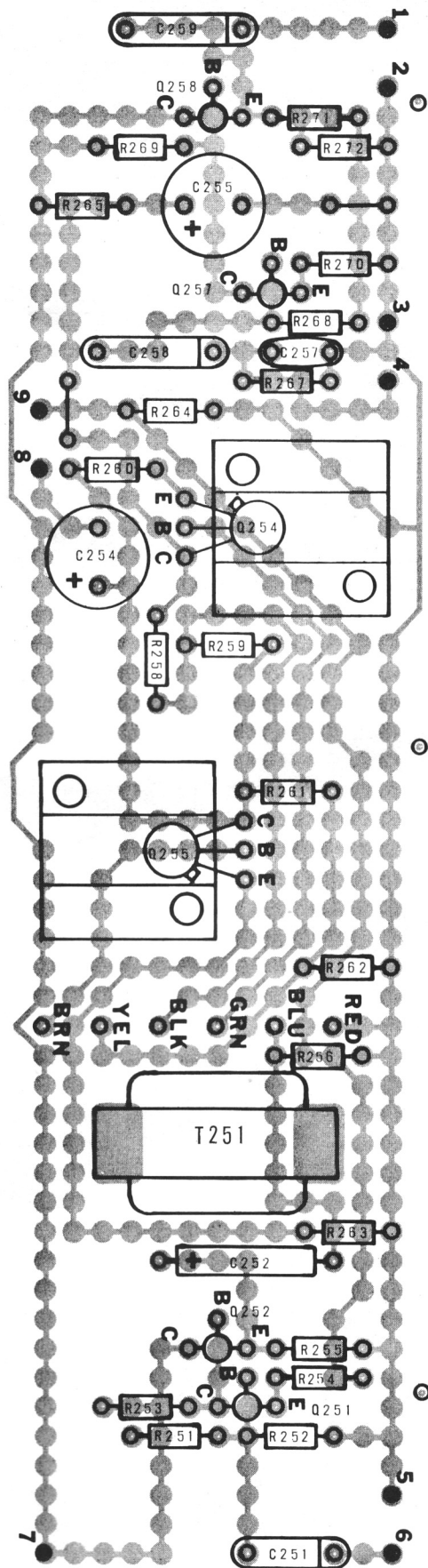

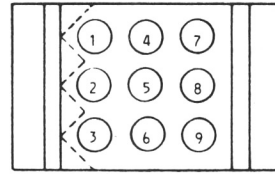

PLUG P251  
(REAR VIEW SHOWN)

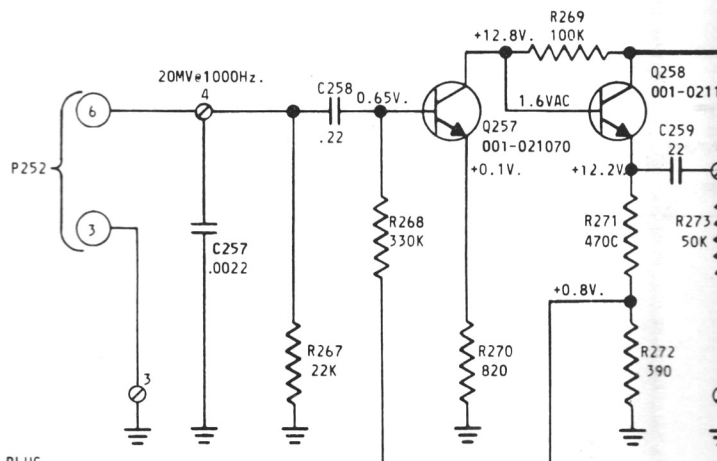
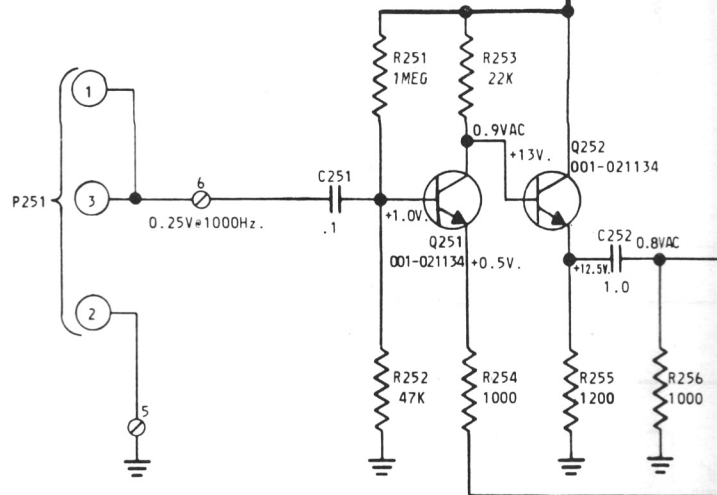

NOTES:

1. (3) SYMBOL DENOTES TERMINAL IN PLUG.
2. (⊗) SYMBOL DENOTES TERMINAL ON PRINTED WIRING BOARD.
3. UNLESS OTHERWISE SPECIFIED:  
ALL RESISTORS ARE IN OHMS, ± 10%, 1/2 WATT;  
ALL CAPACITORS ARE IN MICROFARADS.

094 -034456B

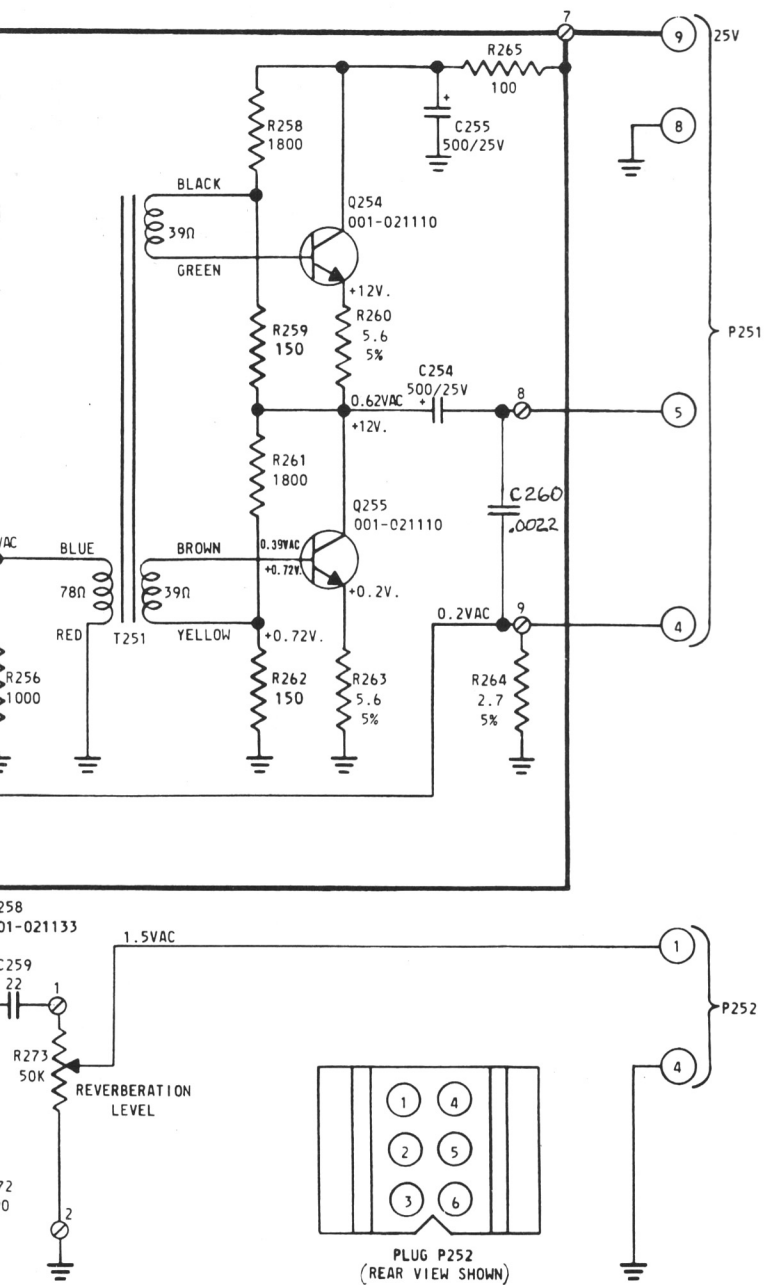
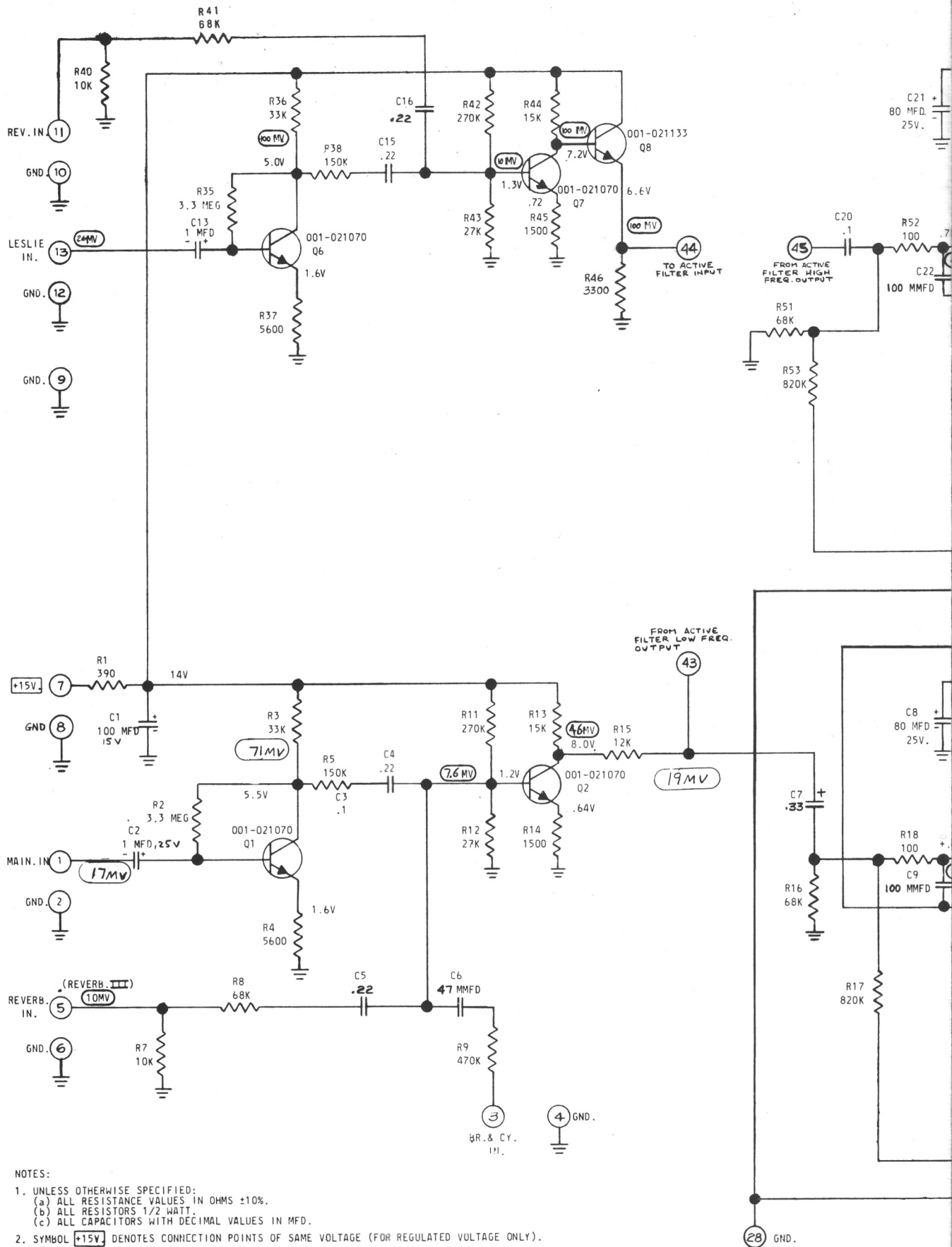

Figure 5-10. Reverberation Amplifier, Layout and Schematic Diagram



NOTES:

1. UNLESS OTHERWISE SPECIFIED:
  - (a) ALL RESISTANCE VALUES IN OHMS  $\pm 10\%$ .
  - (b) ALL RESISTORS 1/2 WATT.
  - (c) ALL CAPACITORS WITH DECIMAL VALUES IN MFD.
2. SYMBOL **+15V** DENOTES CONNECTION POINTS OF SAME VOLTAGE (FOR REGULATED VOLTAGE ONLY).
3. **7** DENOTES PIN NUMBERS.
4. COMPONENTS ENCLOSED BY DASH LINES ARE SHOWN FOR CLARITY ONLY AND ARE NOT MOUNTED ON BOARD ASSEMBLY.

5. DENOTES A.C. VOLTAGE.
6. ALL A.C. VOLTAGES TAKEN WITH 4'DRAWBAR AND KEY 25 DEPRESSED.

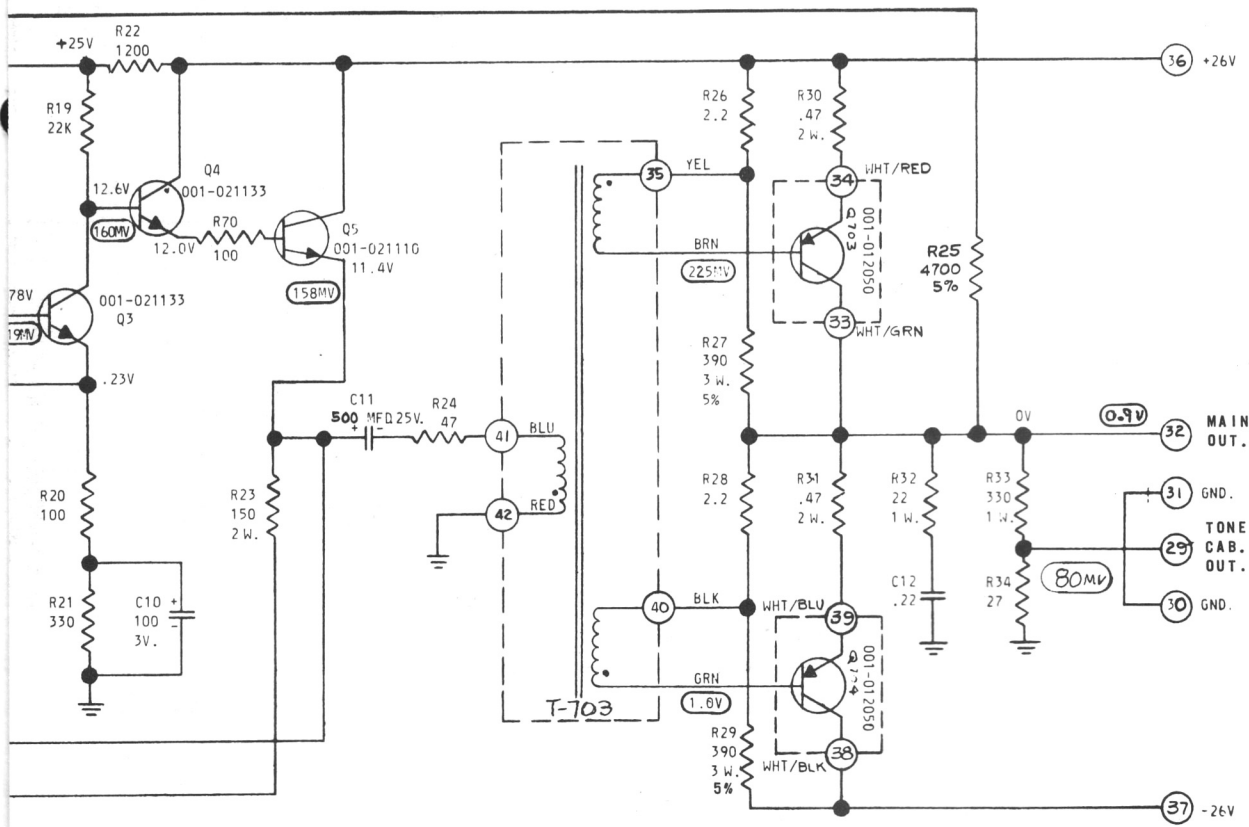
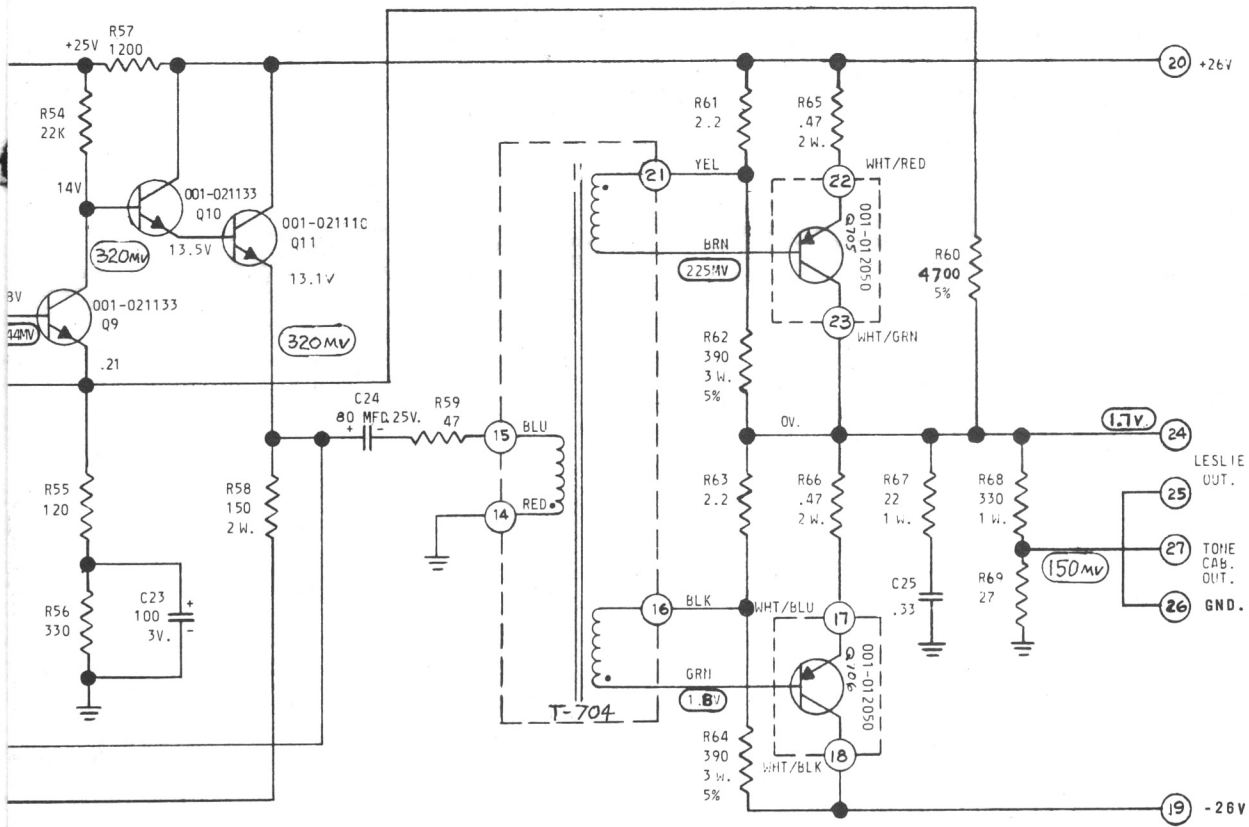

094-044320B

GND  
 25  
 LESLIE  
 OUT. 2  
 WHT-  
 GRN. 2  
 WHT-  
 RED 2  
 YEL. 2  
 GRA.  
 +25V. 2  
 VIO.  
 -25V. 2  
 WHT-  
 BLK. 1  
 WHT-  
 BLU. 1  
 BLK. 1  
 BLU. 1  
 RED 1  
 LESLIE  
 IN. 1



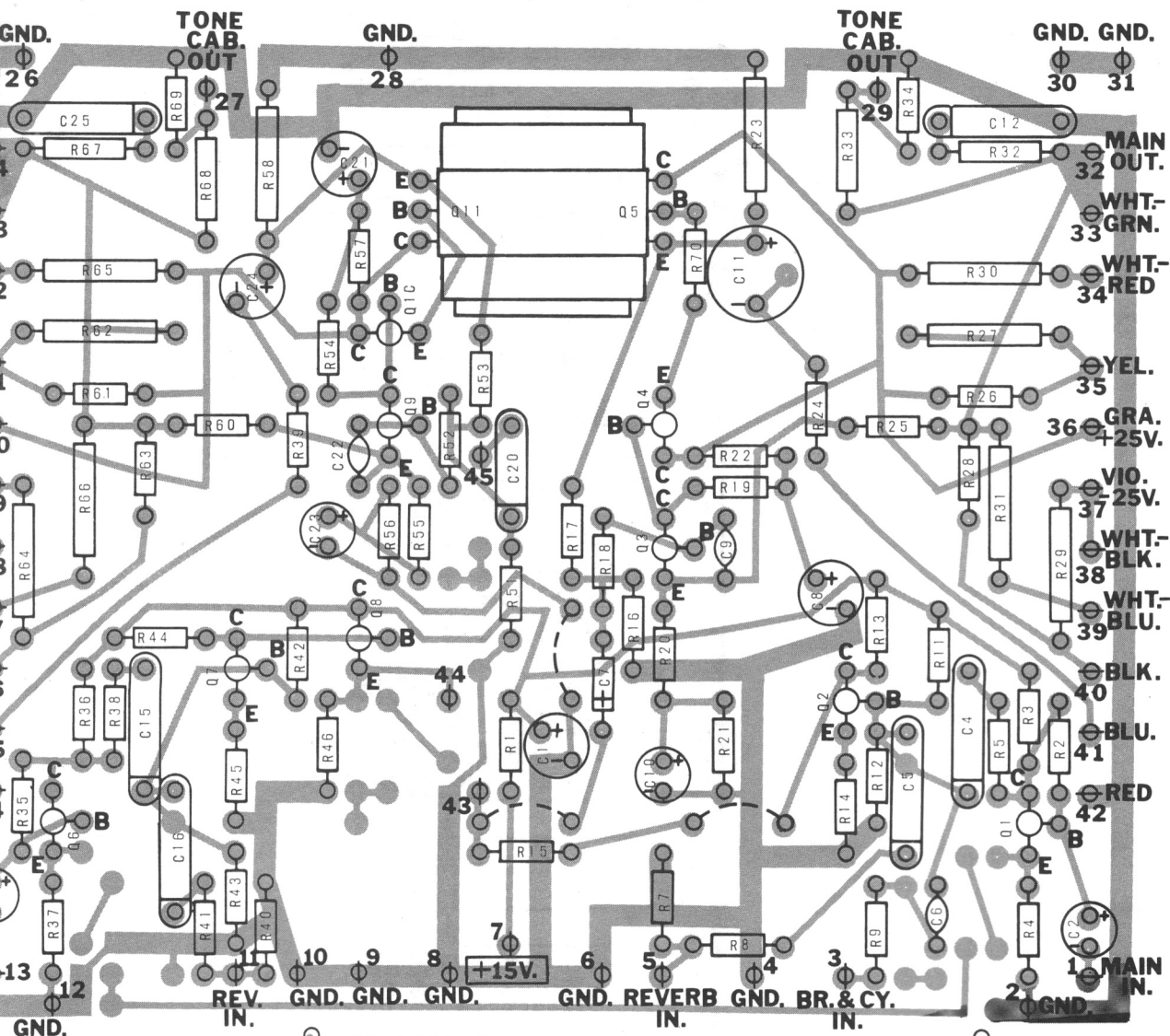

© 023-041224

124-000162

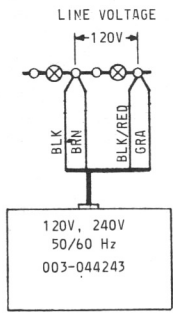

FOR 126-000067

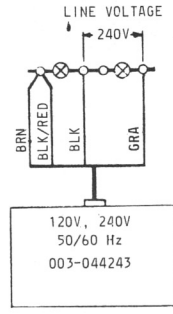

FOR 126-000068

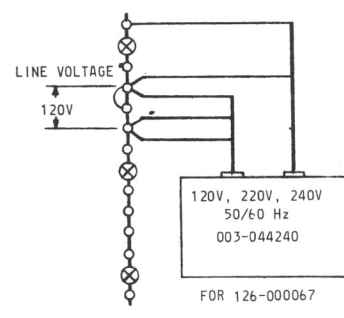
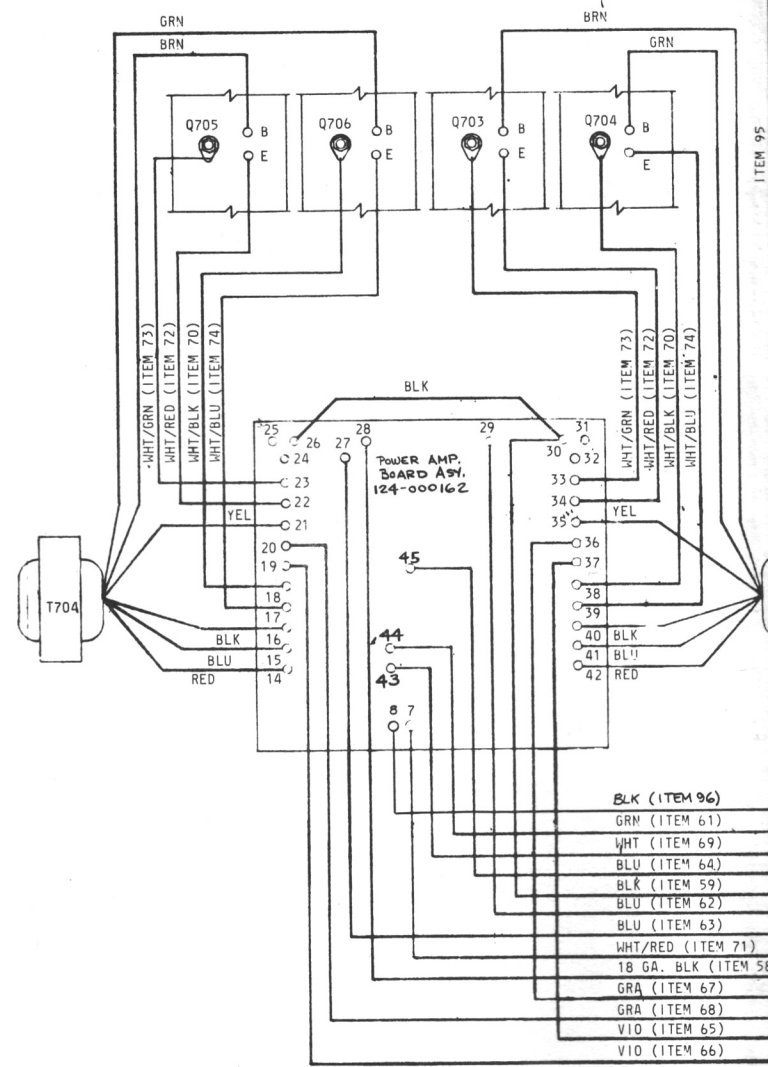

FOR 126-000067

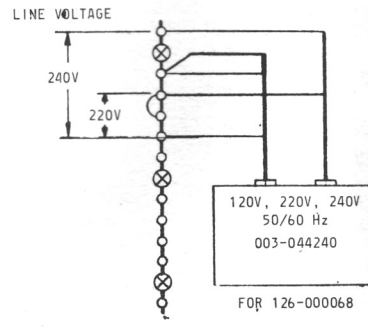

FOR 126-000068

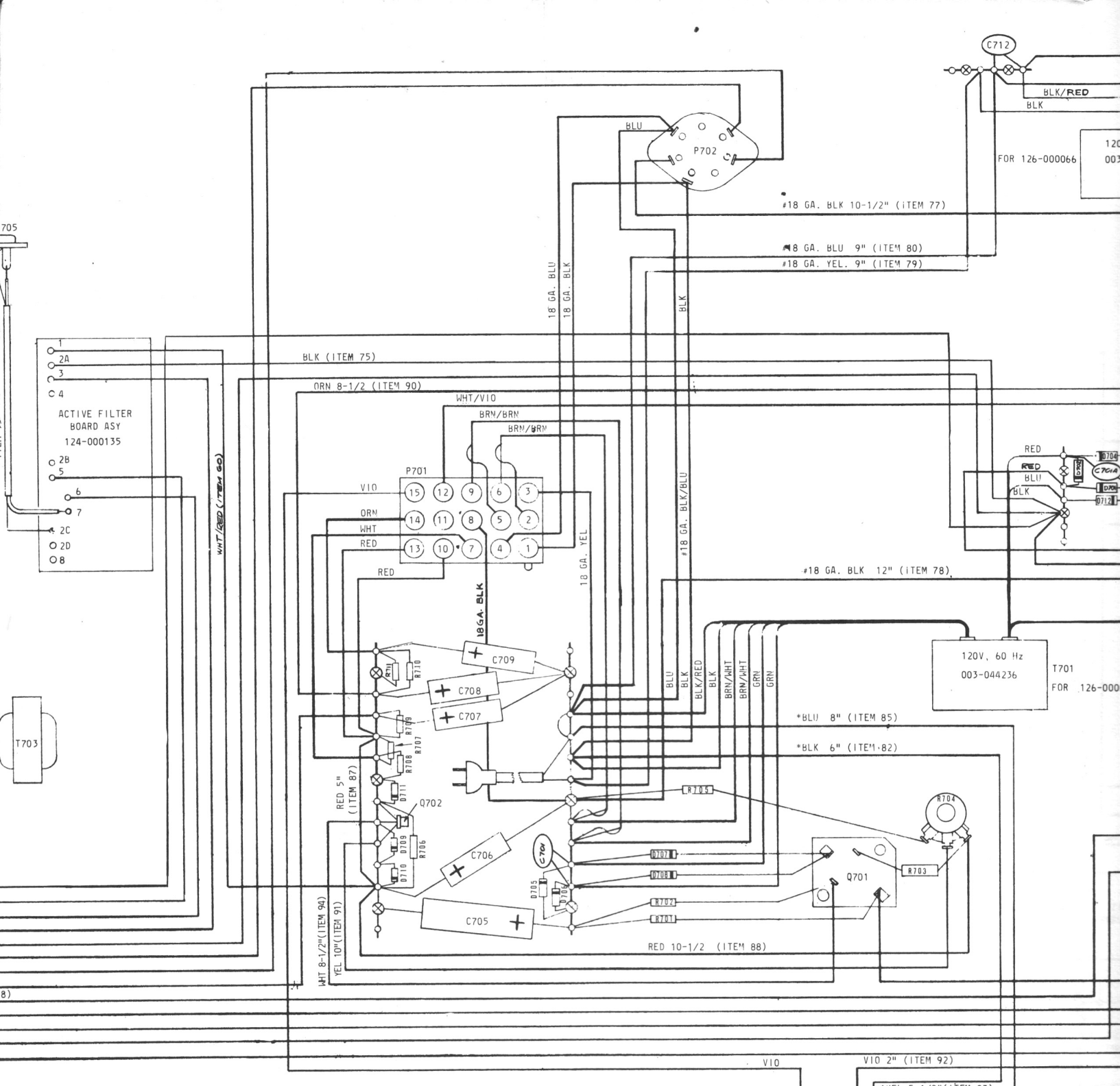

NOTES:

1. 126-000066 AS SHOWN.
2. POWER TRANSFORMER PRIMARY LEAD LOCATIONS ON 126-000067 & 126-000068 DIFFER FROM 126-000066: SEE DETAIL VIEW FOR CORRECT WIRING.
3. MAINTAIN COMPONENT LEAD LENGTHS AS SHORT AS POSSIBLE ON THIS TERMINAL STRIP.
4. WIRES MARKED \* TO BE #22 GA. 1/32 THK. INSULATED WIRE (CAT. 255)

SEE NOTE

T701

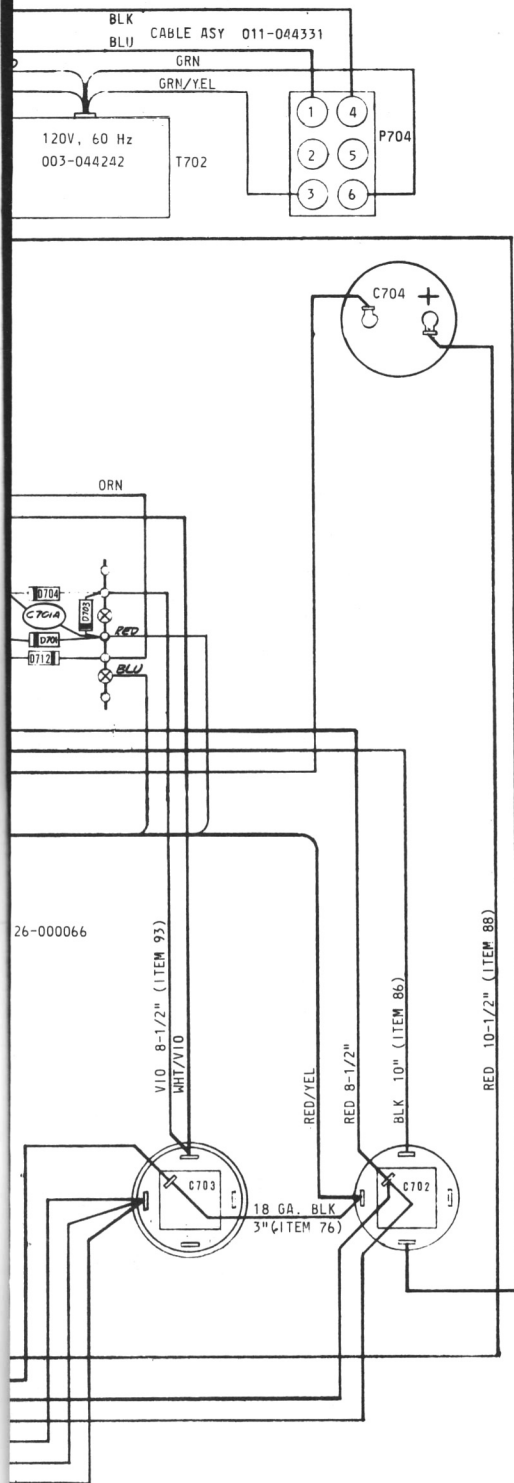

SEE NOTE 3

Figure 5-12. Power Amplifier, Chassis Wiring Diagram

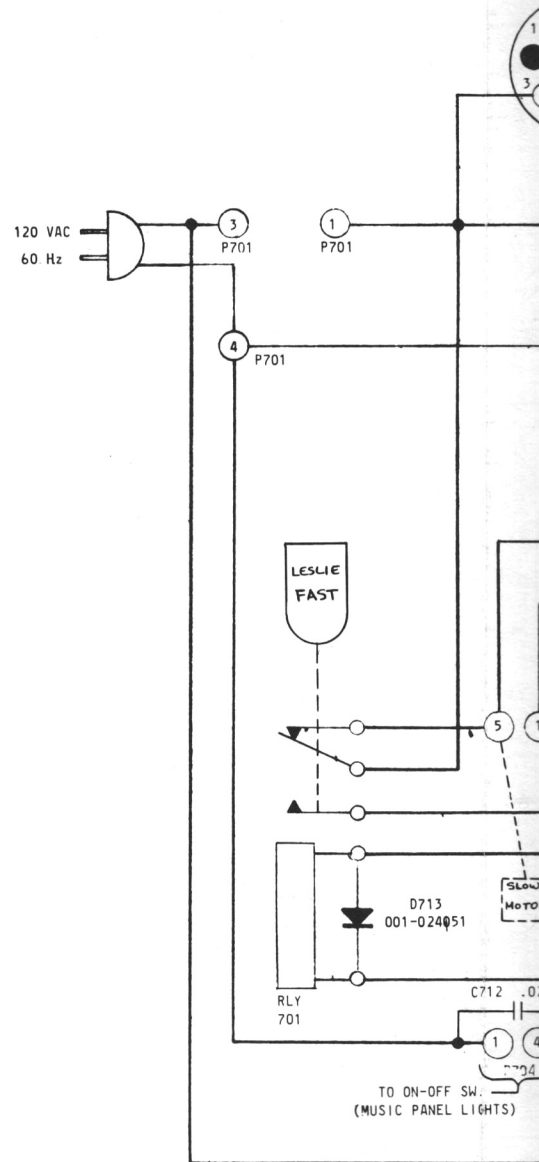

- NOTES:
- UNLESS OTHERWISE SPECIFIED:
  - (a) ALL RESISTANCE VALUES IN OHMS.
  - (b) ALL RESISTORS ARE 1/2 WATT,  $\pm 10\%$ .
  - (c) ALL CAPACITOR VALUES ARE IN MFD.
2. SYMBOL DENOTES CONNECTION POINTS OF SAME VOLTAGE (FOR
  3. SYMBOL DENOTES PIN NUMBERS ON PRINTED WIRING BOARDS.
  4. SYMBOL DENOTES PINS ON PLUGS.
  5. ALL PLUG VIEWS (P701, P702, P703 & P 704) SHOWN FROM MAT

Figure 5-13. Power Supply, Schematic Diagram

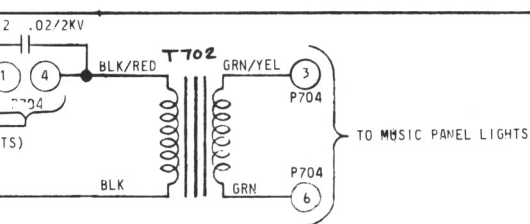
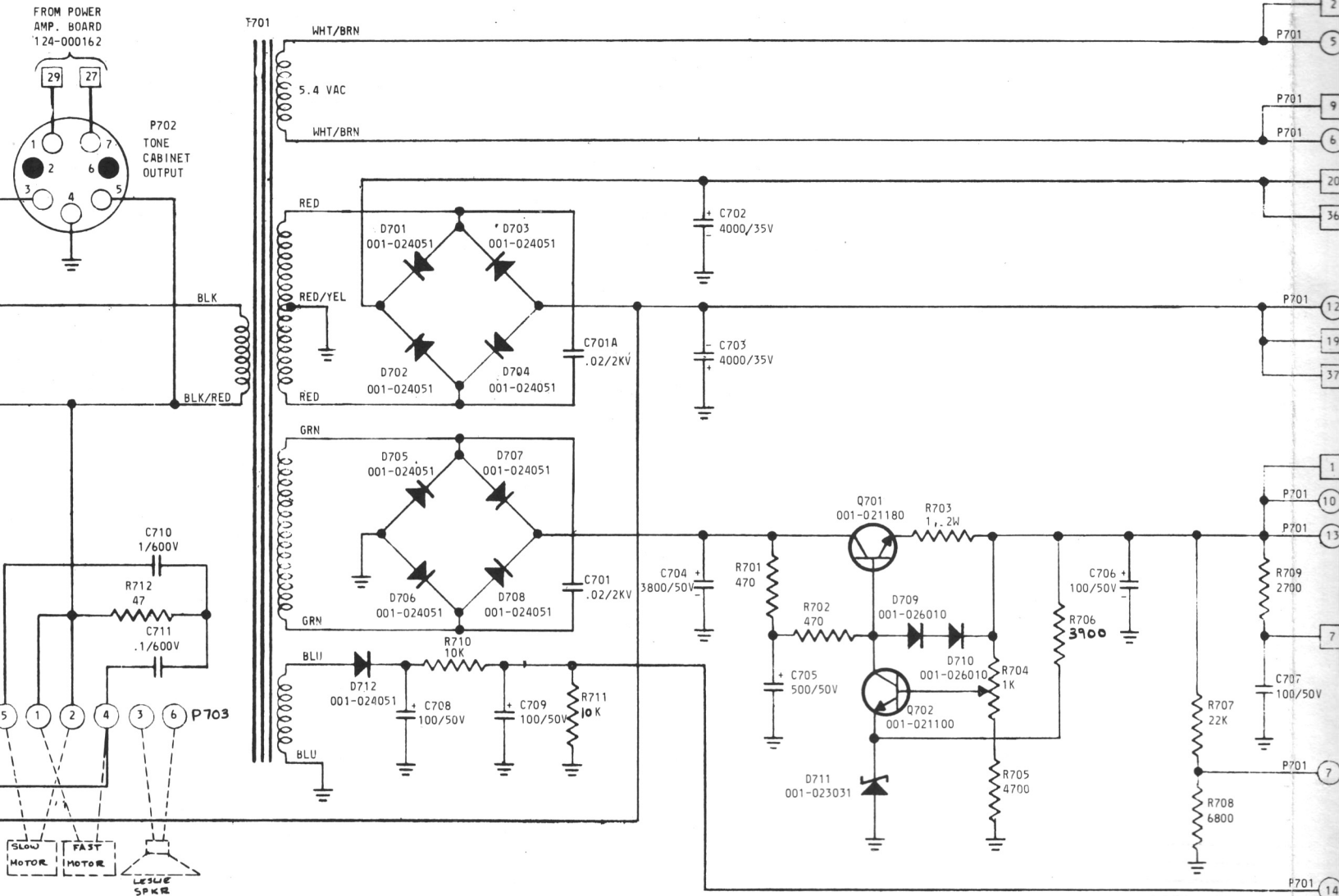

GE (FOR REGULATED VOLTAGES ONLY).  
BOARDS.

FROM MATING PLUG END.

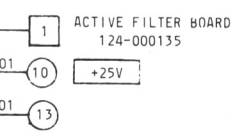
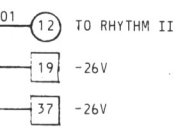
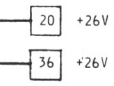

INDEX RIB

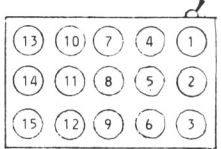

P701 (POWER VOLTAGES)

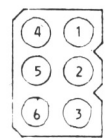

P703 (LESLIE)

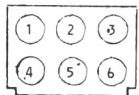

P704 (MUSIC LIGHT)

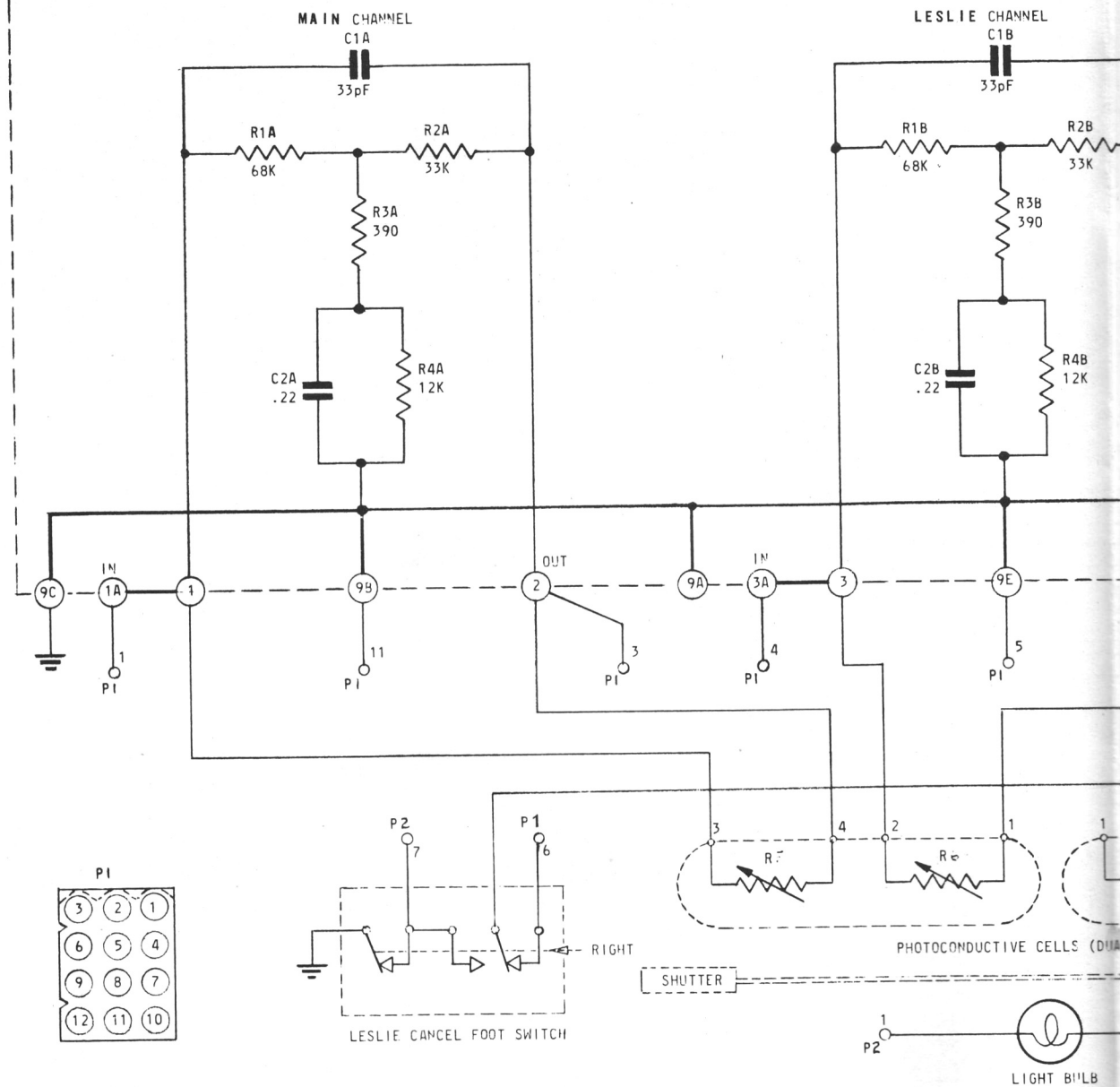

NOTES:



1. UNLESS OTHERWISE SPECIFIED:
  - a. ALL RESISTORS 1/2 WATT.
  - b. ALL RESISTANCE VALUES IN OHMS,  $\pm 10\%$ .
  - c. ALL CAPACITORS WITH DECIMAL VALUES IN MF.
2. SYMBOL  DENOTES NUMBERED PIN IN PLUG OR RECEPTACLE.
3. SYMBOL  DENOTES NUMBERED PIN ON P.W. BOARD.

Figure 5-14. Swell Pe



PEDAL)

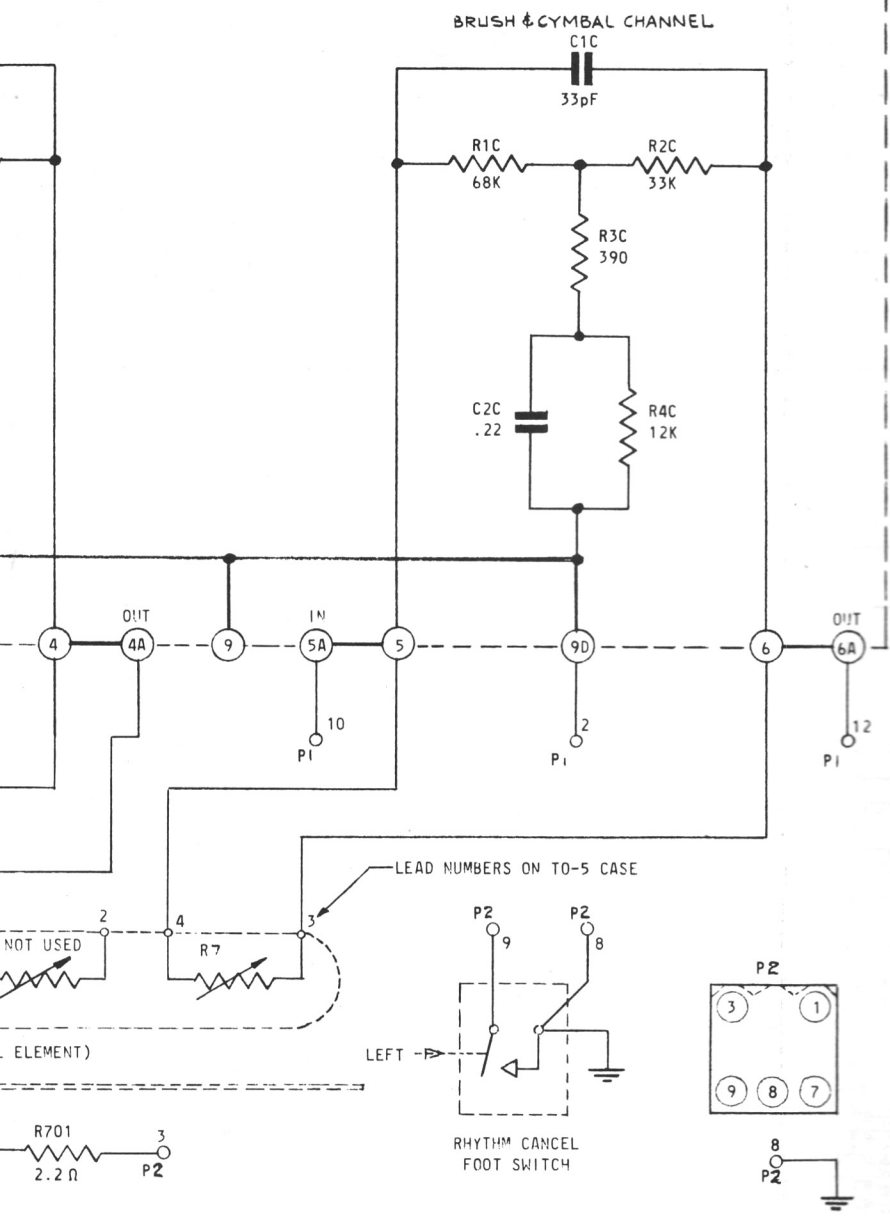

094-044400

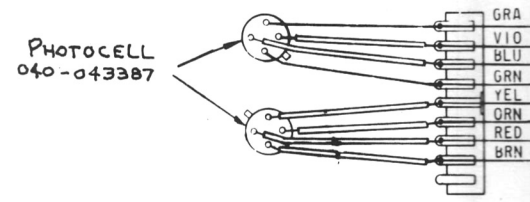

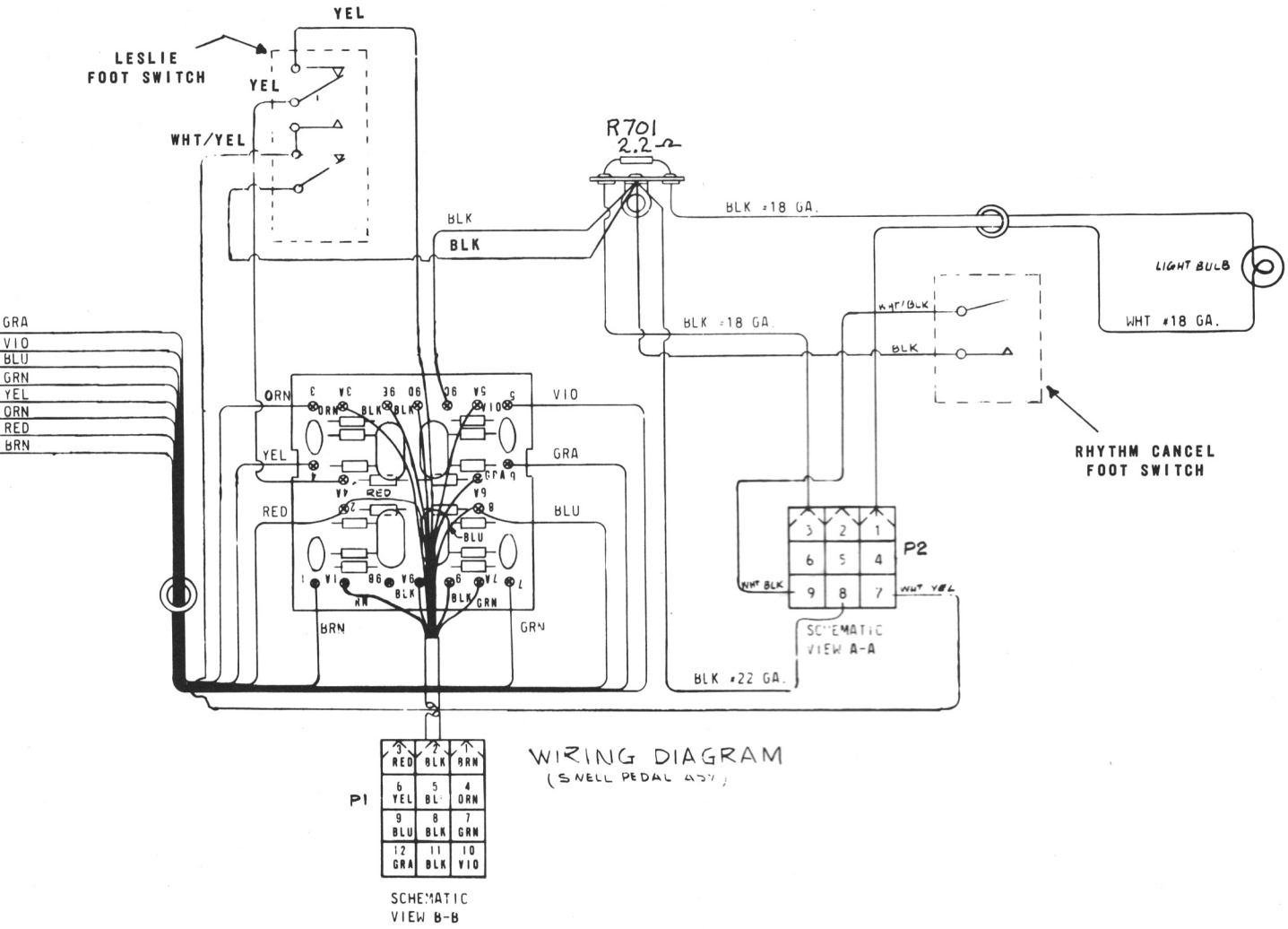

Figure 5-15. Swell Pedal, Wiring Diagram

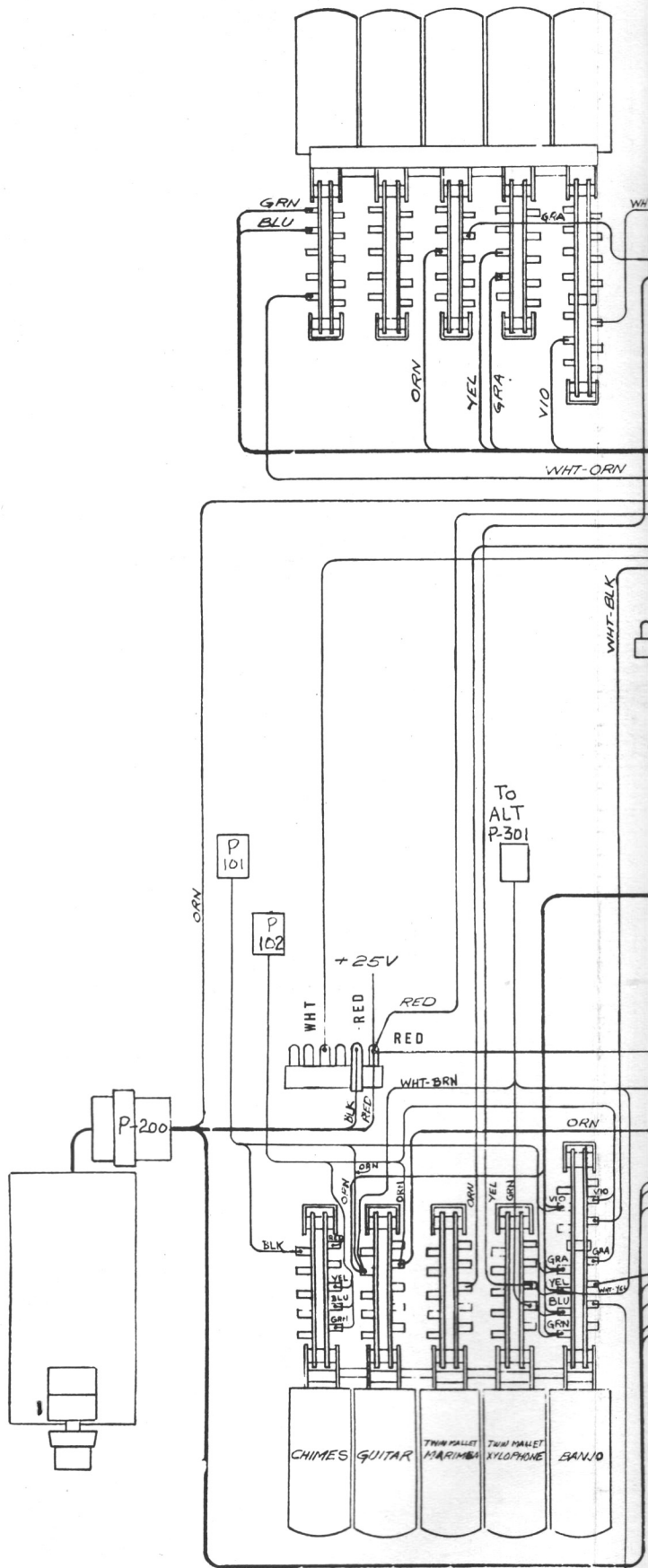
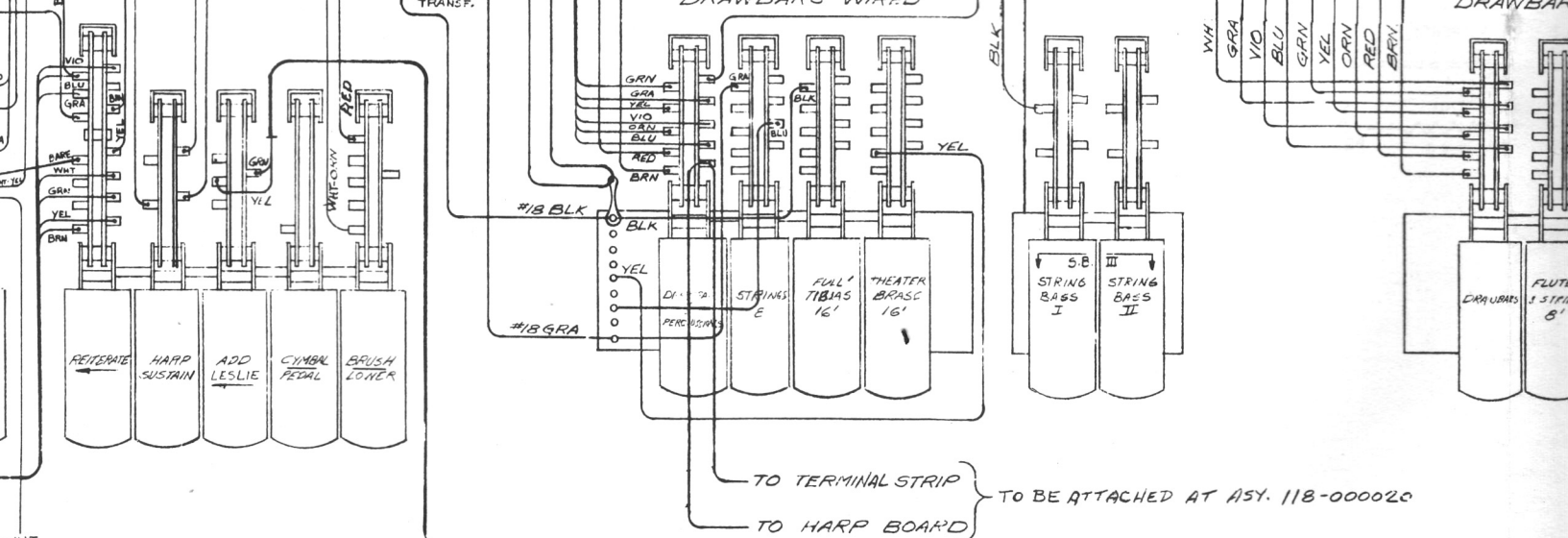
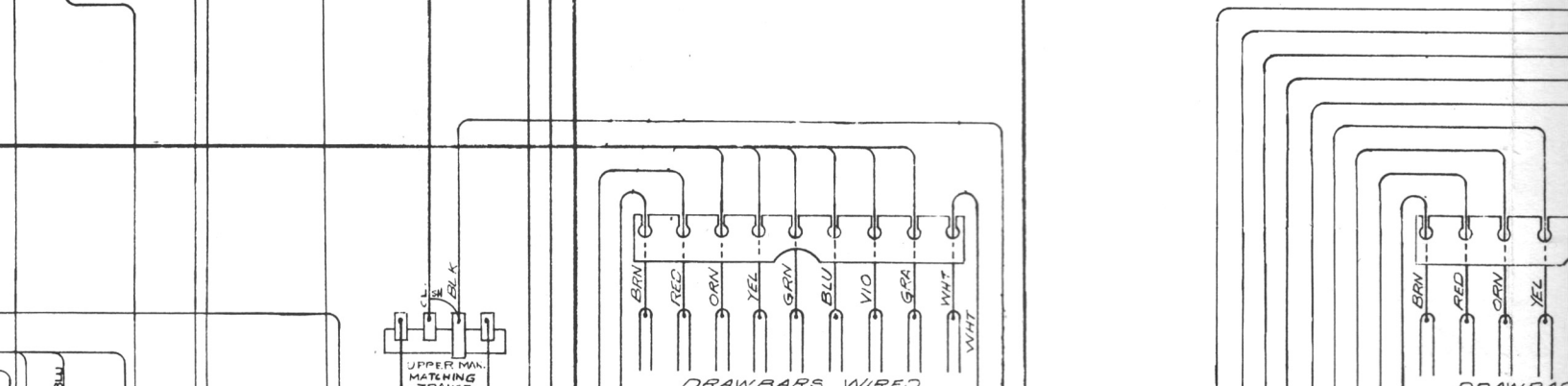
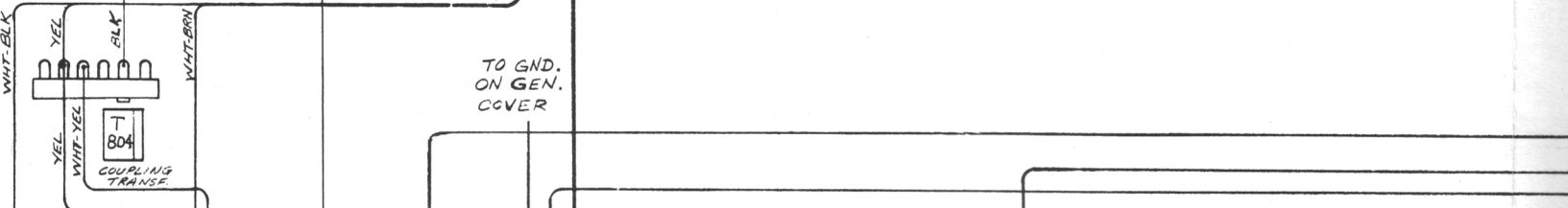
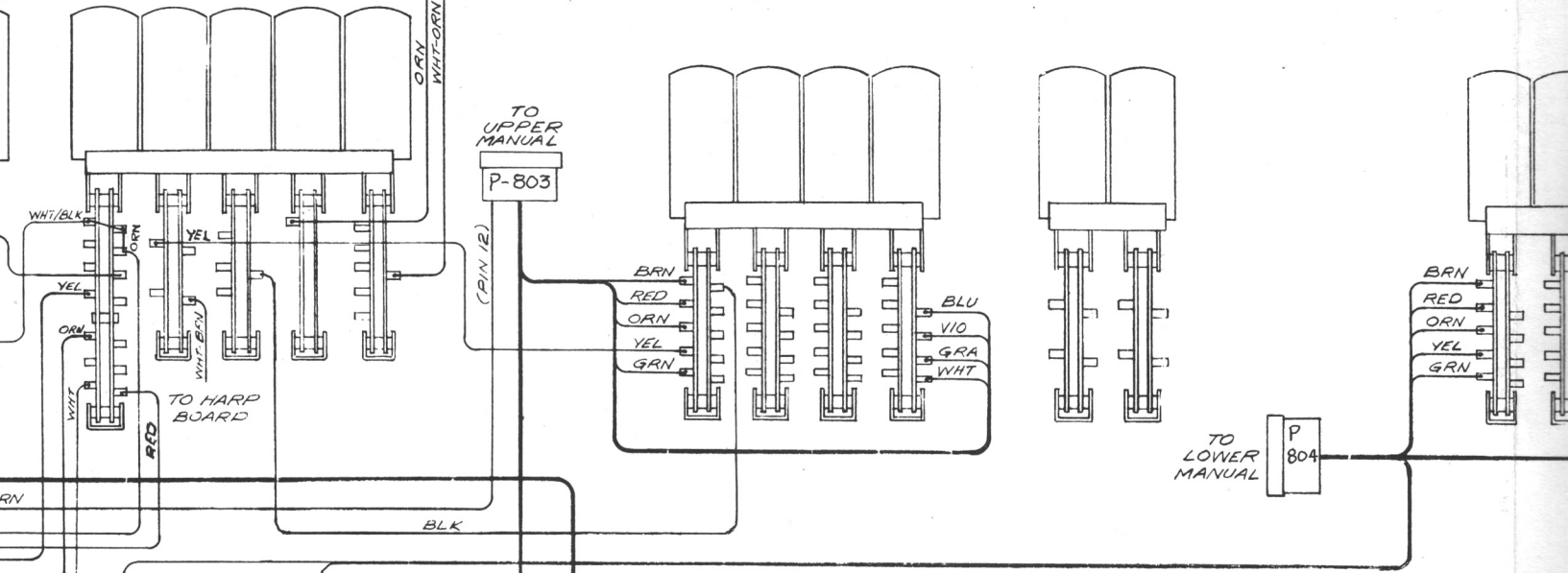

Figure 5-16. Control Panel Wiring Diagram

TO BRUSH &  
CYMBAL BOARD

BOTTOM VIEW  
OF LOWER LUGS ON SWITCHES



TOP VIEW  
OF UPPER LUGS ON SWITCHES

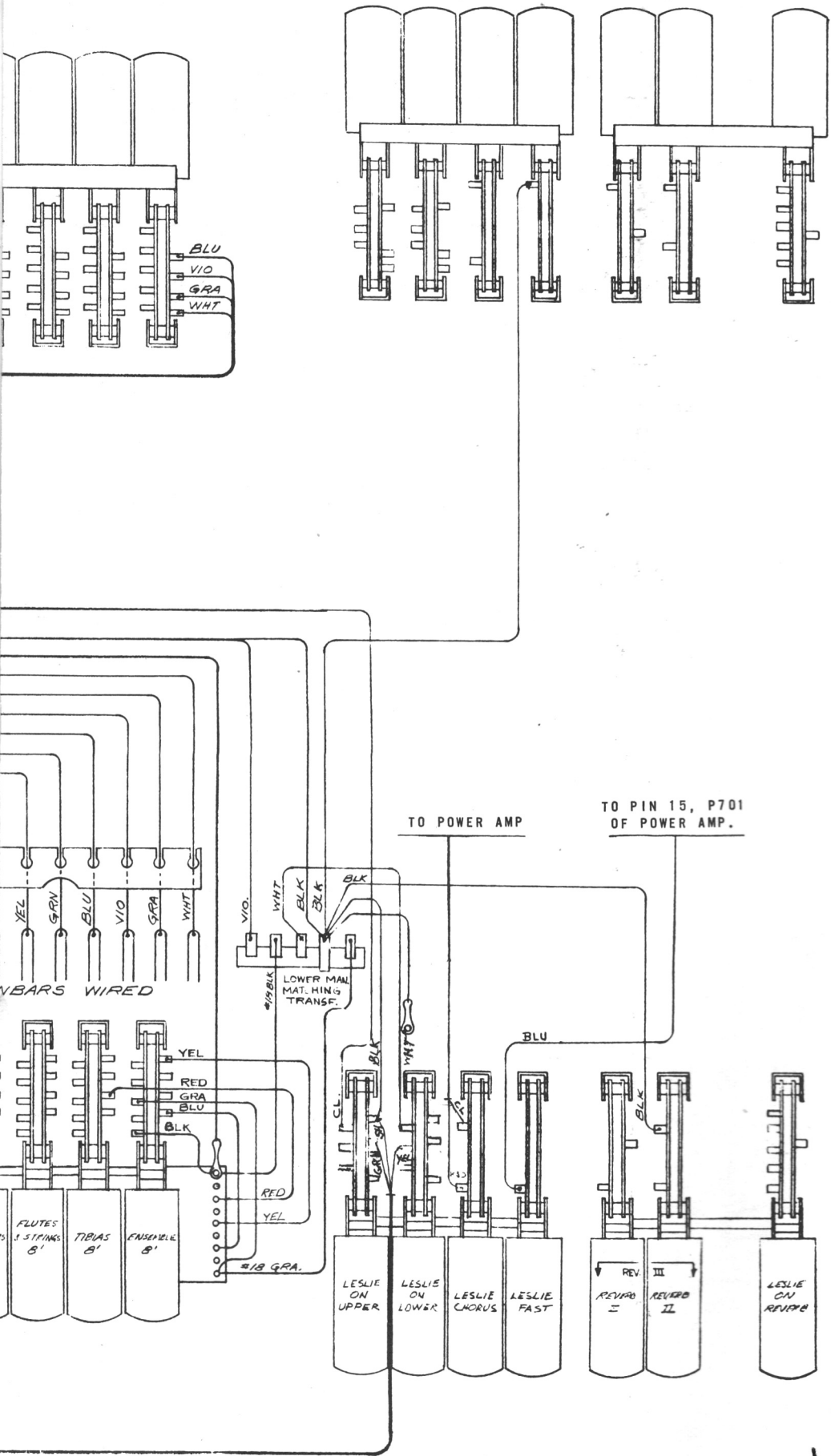

TOP VIEW

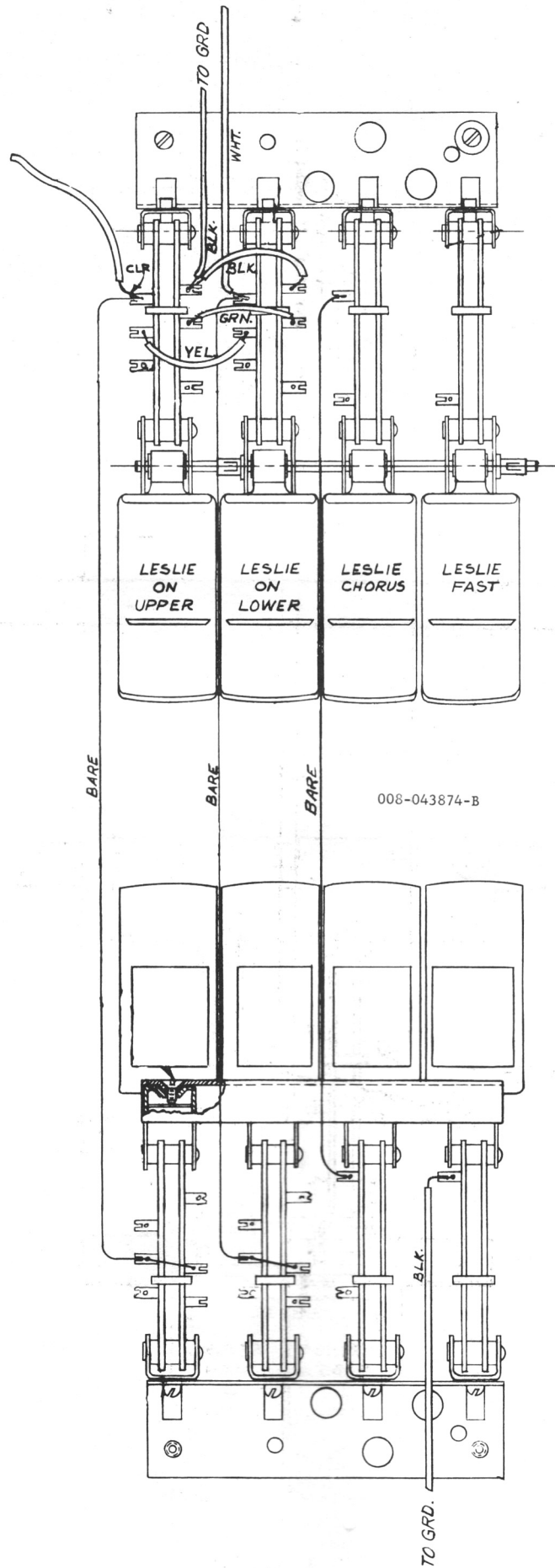

BOTTOM VIEW

Figure 5-17. Leslie Switch Assembly, Wiring Diagram

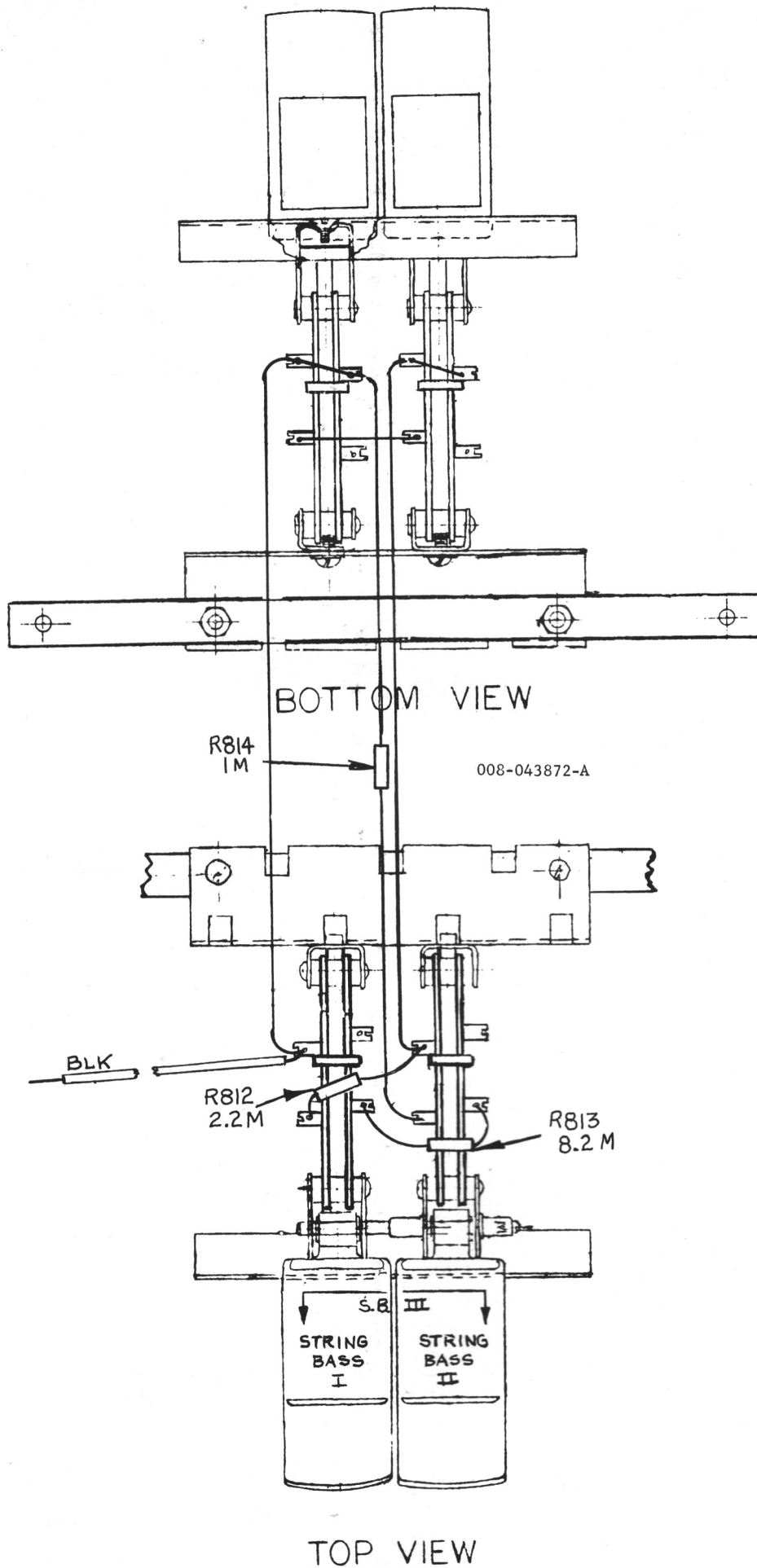

Figure 5-18. Pedal Sustain Switch Assembly, Wiring Diagram

008-043869-A

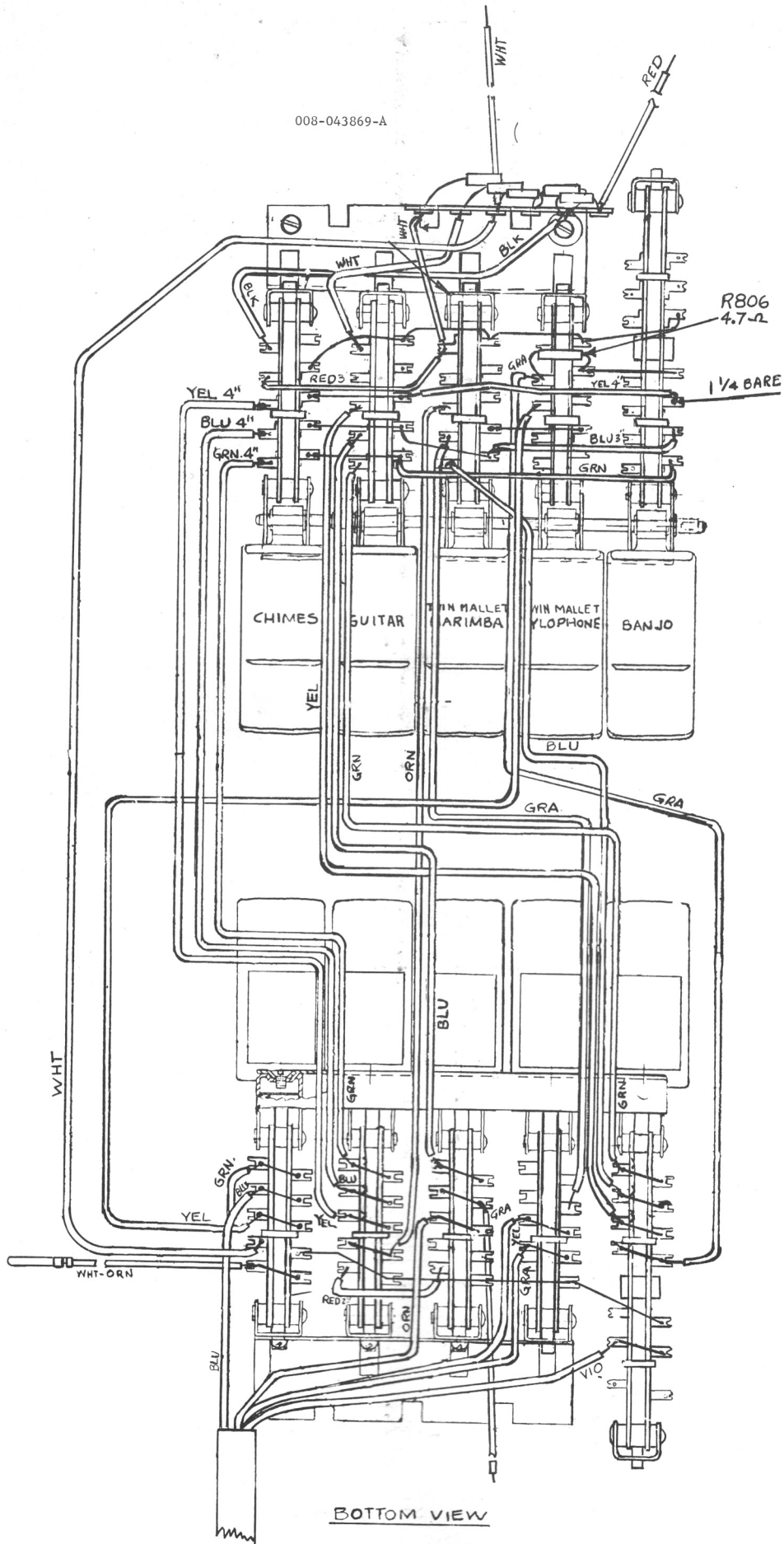
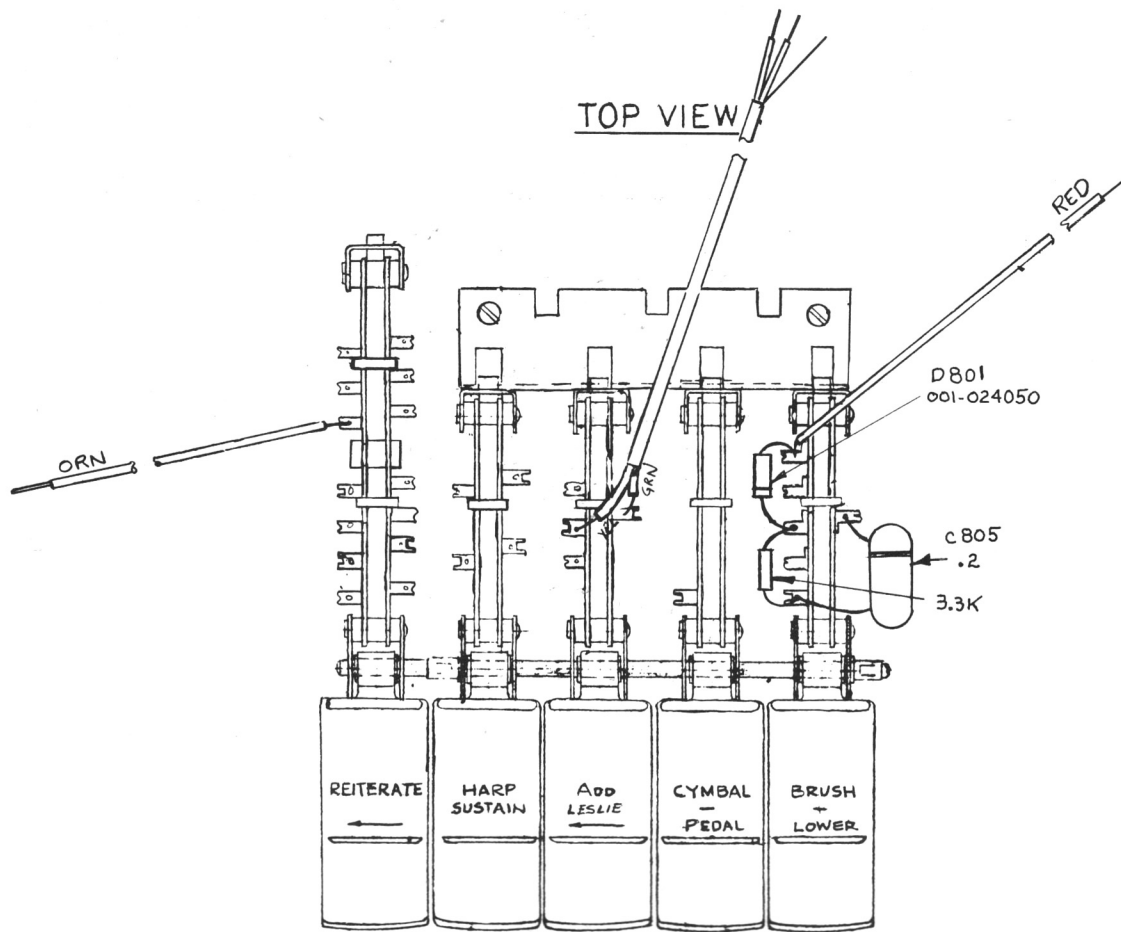

Figure 5-19. Percussion Switch Assembly No. 1, Wiring Diagram





008-043870-B

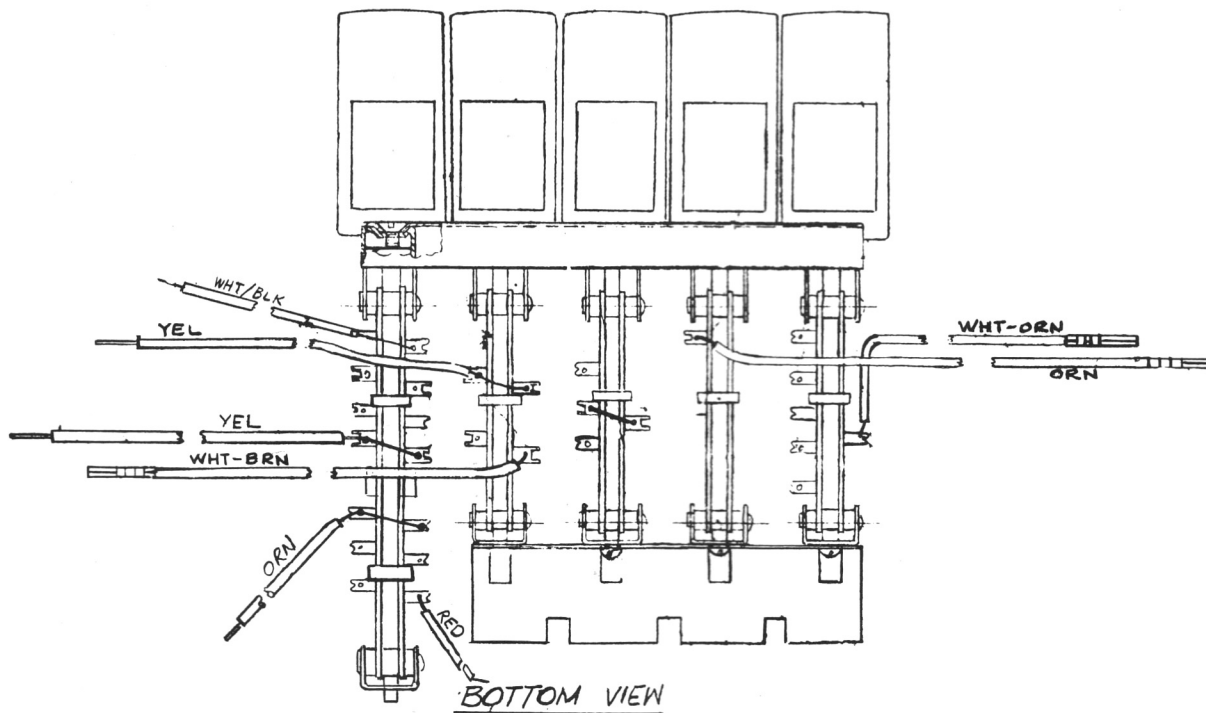
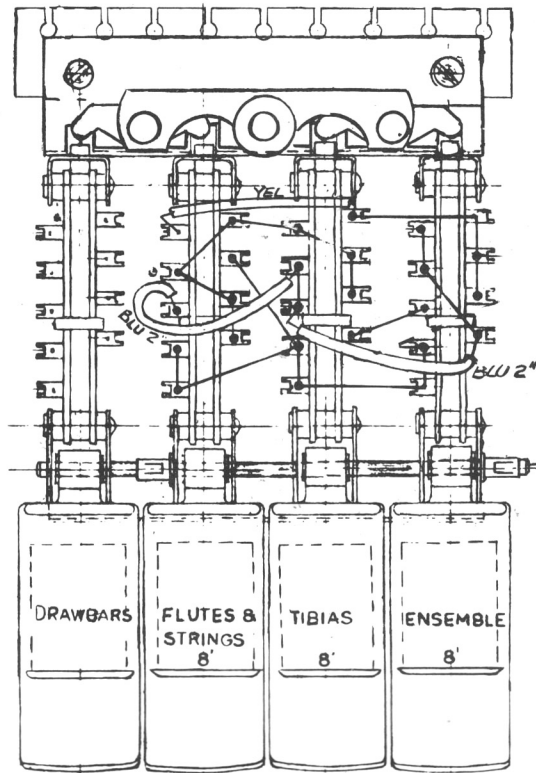
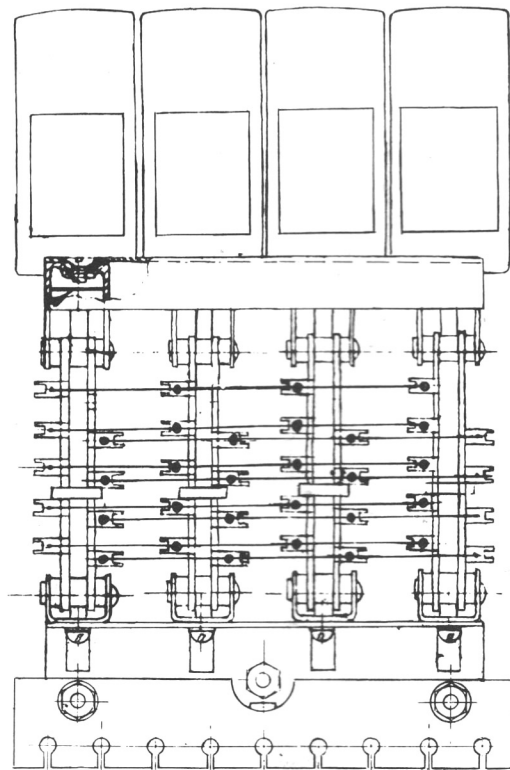

Figure 5-20. Percussion Switch Assembly No. 2, Wiring Diagram

TOP VIEW



008-043873-A



BOTTOM VIEW

Figure 5-21. Lower Preset Switch Assembly, Wiring Diagram

TOP VIEW

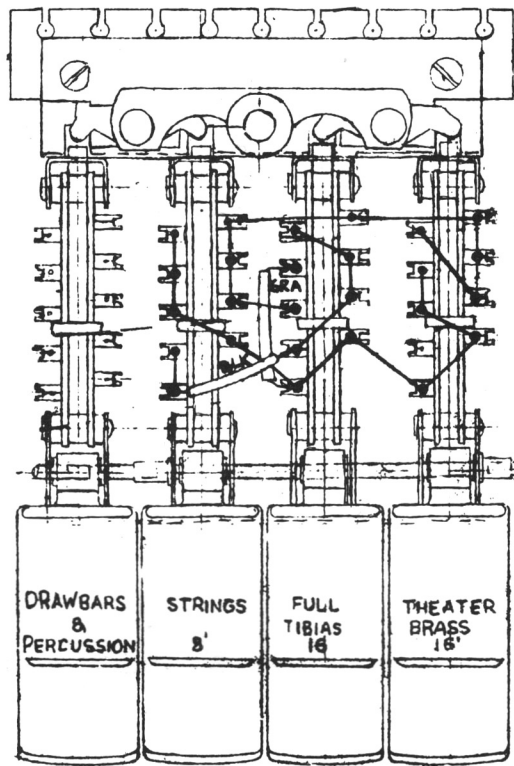

008-043871-B

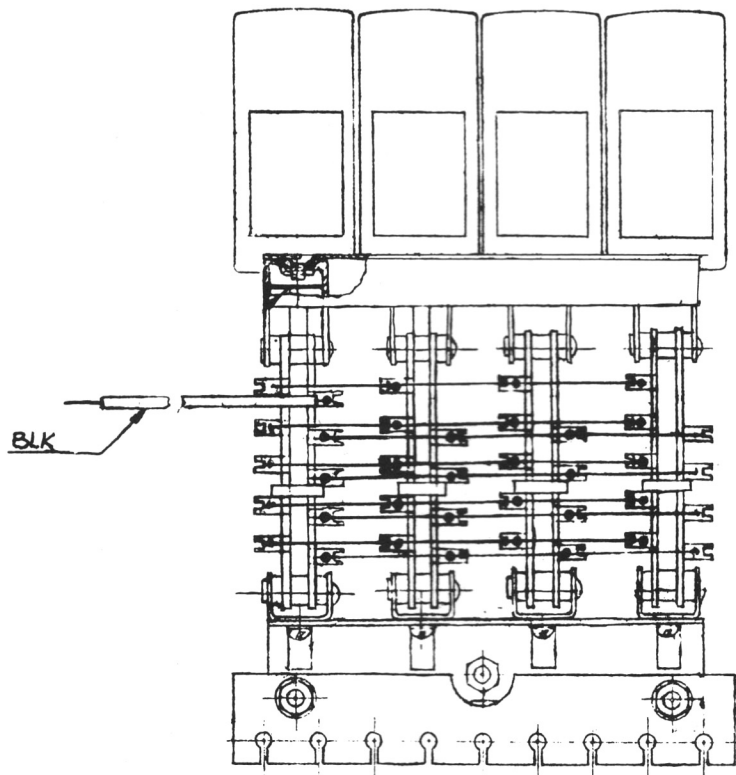

BOTTOM VIEW

Figure 5-22. Upper Preset Switch Assembly, Wiring Diagram

TOP VIEW

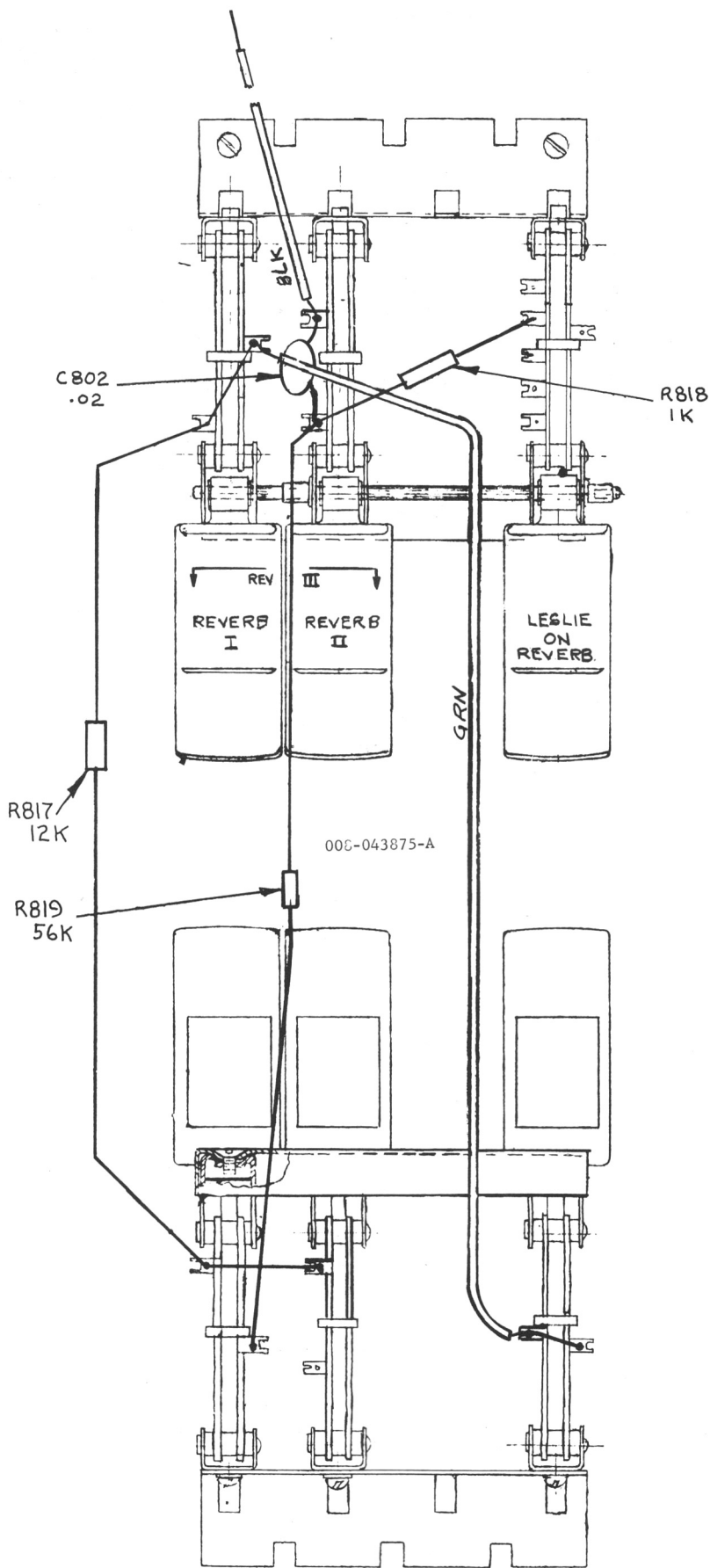

BOTTOM VIEW

Figure 5-23. Reverb Switch Assembly, Wiring Diagram

Figure 5-24. Harp Keyer and Preampfier, Schematic Diagram

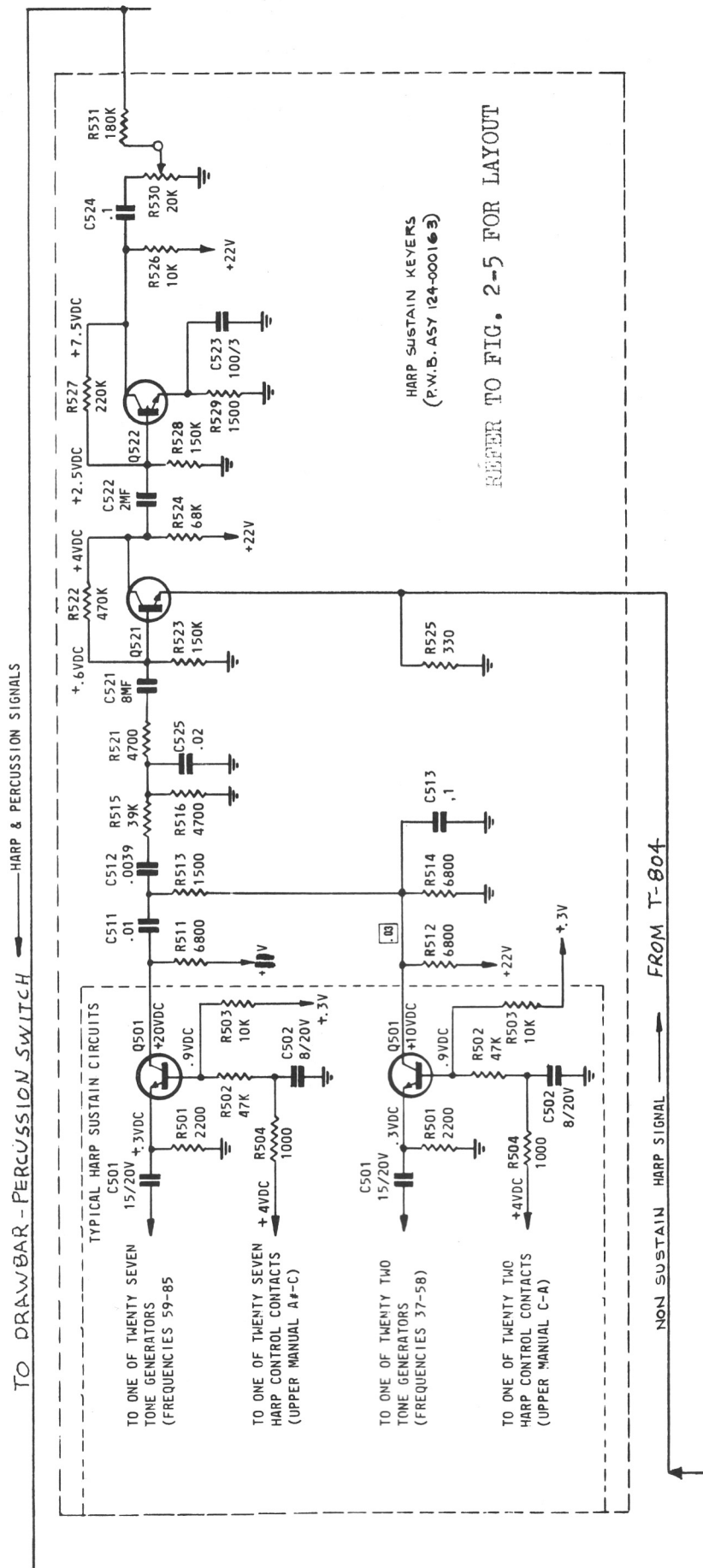

# SECTION VI PARTS LIST

## INDEX

	<i>Page</i>	
<b>CONTROL PANEL ASSEMBLY</b> .....	6-3	
Control Switch Base & Support Assembly .....	6-3	
Manual Stop Switch Assembly (Drawbars) .....	6-3	
Control Switch Assemblies .....	6-3	
<b>LOWER MANUAL ASSEMBLY</b> .....	6-6	
<b>UPPER MANUAL ASSEMBLY</b> .....	6-6	
Playing Key .....	6-6	
End Blocks .....	6-6	
<b>GENERATOR &amp; MOTOR ASSEMBLY</b> .....	6-6	
<b>PRINTED WIRING BOARDS</b> .....	6-6	
Preamplifier Board Assembly	124-000161 .....	6-6
Cymbal/Brush Board Assembly	124-000020 .....	6-7
Power Amplifier Board Assembly (Mounted on Power Amplifier)	124-000162 .....	6-8
Active Filters Board Assembly (Mounted on Power Amplifier)	124-000135 .....	6-9
Harp Sustain Keyer Assembly	124-000163 .....	6-9
Harp Keyer Board Assemblies	124-000046/47 .....	6-9
Harp Keyer & Preamplifier Board Assembly	124-000165 .....	6-9
Pedal Board Assembly 063-044315		6-10
Sine Wave Amplifier Board Assembly No. 1	124-000139 .....	6-10
Sine Wave Amplifier Board Assembly No.2	124-000154 .....	6-10
Pedal Keyer Board Assembly No.1	124-000138 .....	6-10
Pedal Keyer Board Assembly No.2	124-000153 .....	6-10
Pedal Preamplifier Board Assembly	124-000137 .....	6-11
Pedal Master Board	124-000136 .....	6-11
Percussion Gate Amplifier Board Assembly	124-000003 (P/O 117-000001) .....	6-11
Alternate Percussion Gate Amplifier Board Assembly	124-000004 (P/O 117-000002) .....	6-12
Reverberation Amplifier Board Assembly	124-000007 (P/O 117-000003) .....	6-12
Swell Pedal Board Assembly	124-000126 .....	6-14
<b>PERCUSSION GATE AMPLIFIER ASSEMBLY</b>	117-000001 .....	6-11
<b>ALTERNATE PERCUSSION GATE AMPLIFIER ASSEMBLY</b>	117-000002 .....	6-12
<b>REVERBERATION AMPLIFIER ASSEMBLY</b>	117-000003 .....	6-12
<b>PERCUSSION &amp; REITERATION DRIVE ASSEMBLY</b>	128-000001 .....	6-13
<b>POWER AMPLIFIER ASSEMBLY</b>	126-000066 .....	6-14
<b>WOODWORK</b> .....	6-14	

	<i>Page</i>
<b>MISCELLANEOUS</b> .....	6-15
Swell Pedal Assembly .....	6-15
Leslie Speaker Assembly .....	6-15
Speakers .....	6-15
Music Illuminator Assembly .....	6-15
 <b>LESLIE TREMOLO UNIT</b> .....	 6-15

## CONTROL PANEL ASSEMBLY 120-000044

Control Switch Base and Support Assembly	061-043485
Control Panel Assembly (Left Hand)	061-030592
Control Panel Assembly (Center)	061-043488
Control Panel Assembly (Right Hand)	061-043486
Matching Transformer and Bracket Assembly-Upper Manual (T802)	003-043908
Matching Transformer and Bracket Assembly-Lower Manual (T801)	003-043909
Percussion and Reiteration Driver Assembly	128-000001
Lampholder Assembly	016-034444
Pilot Light Lens	016-031454
Felt Washer	042-020820
Push On Clip (For Lens)	013-031468
Pilot Lamp	016-022885
Plastic Cap (Black)	025-024968
Hex Nut	999-001208
Shakeproof Lockwasher } For Mounting Reit. Chassis	999-000848
Knob (Brush and Cymbal Control)	031-025912
Knob (Reiteration Rate)	031-025911
Manual Stop Switch Assembly (Complete Drawbar Assembly)	120-000045
Manual Stop Switch Assembly (Upper Only)	120-000017
Manual Stop Switch Assembly (Lower Only)	120-000018
Mounting Block Assembly (Pedal Only)	063-043506
Contact Spring Assembly	012-033222
Drawbar Stop	025-040198
Stop Slide Insulator	036-032553
Stop Slide	028-032049
Stop Channel	025-027829
#4-24 x 3/8 Round Head Screw (Drawbar Knob Mounting)	901-030514
Screw (Drawbar Stop Mounting)	846-010414
Stamped Stop Knob Brown 16'	031-034331
Stamped Stop Knob Black 16'	031-034332
Stamped Stop Knob Ivory 8'	031-034333
Stamped Stop Knob Brown 8'	031-034334
Stamped Stop Knob Black 8'	031-034335
Stamped Stop Knob Brown 5 1/3'	031-034337
Stamped Stop Knob Ivory 4'	031-034338
Stamped Stop Knob Black 2 2/3'	031-034339
Stamped Stop Knob Ivory 2'	031-034340
Stamped Stop Knob Black 1 3/5'	031-034341
Stamped Stop Knob Black 1 1/3'	031-034342
Stamped Stop Knob Ivory 1'	031-034343
Harp Coupling Transformer Assembly T804	003-028651
Mounting Bracket	062-030006
Coil and Bobbin	003-030075
Cup Core (Ferrite)	024-022427
Ferrite Washer	024-022451
Spring	012-041491
Truss Head Machine Screw (For Mounting Switch Assemblies) (Black Phillips Head)	845-070318

## PERCUSSION SWITCH ASSEMBLY #1

008-043869

Switch Panel and Bracket Assembly (Chimes, Marimba, Xylophone, Guitar)	008-027668
Switch Panel and Bracket Assembly (Banjo)	008-030047
Control Tab CHIMES	031-034629
Control Tab GUITAR	031-034619
Control Tab MARIMBA TWIN MALLET	031-034631
Control Tab XYLOPHONE TWIN MALLET	031-034632
Control Tab BANJO	031-034620
Tubular Clip	013-028002



Shaft			020-037239
Limit Spacer			044-030602
Mounting Bracket			035-024351
Flat Head Machine Screw			839-040214
Lever Mounting Bracket			035-024335
Sems Round Head Machine Screw			821-040314
Over Center Spring			012-038938
Resistor	4.7 $\Omega$	R806	600-021561
Resistor	5600 $\Omega$	R802	600-020671
Resistor	8200 $\Omega$	R801	600-020711
Resistor	470K	R804	600-021131
Resistor	1.5Meg	R803	600-021251
Resistor	2.2Meg	R805	600-021291

#### PERCUSSION SWITCH ASSEMBLY #2

008-043870

Switch Panel and Bracket Assembly (Reiterate)			008-030047
Switch Panel and Bracket Assembly (Harp Sustain)			008-027679
Switch Panel and Bracket Assembly (Add Leslie)			008-027678
Switch Panel and Bracket Assembly (Cymbal-Pedal)			008-027671
SWitch Panel and Bracket Assembly (Brush-Lower)			008-027670
Control Tab	REITERATE		031-034639
Control Tab	HARP SUSTAIN		031-034624
Control Tab	ADD LESLIE		031-043461
Control Tab	CYMBAL-PEDAL		031-037542
Control Tab	BRUSH-LOWER		031-037543
Tubular Clip			013-028002
Shaft			020-037239
Mounting Bracket			035-024351
Limit Spacer			044-030602
Over Center Spring			012-038938
Capacitor, Mylar	.2 mfd	C805	413-010292
Resistor	3300 $\Omega$		600-020611
Diode	D801		001-024050
Flat Head Machine Screw			839-040214
Round Head Machine Screw			821-040314

#### UPPER PRESET SWITCH ASSEMBLY 008-043871

Switch Panel and Bracket Assembly (Drawbar-Percussion)			008-027667
Switch Panel and Bracket Assembly (Strings 8', Full Tibias 16' Theater Brass 16')			008-027674
Control Tab	DRAWBAR AND PERCUSSION		031-037524
Control Tab	STRINGS 8'		031-043448
Control Tab	FULL TIBIAS 16'		031-037526
Control Tab	THEATER BRASS 16'		031-043449
Canceling Linkage Assembly			060-037190
Mounting Bracket			035-024205
Lever Mounting Bracket			035-024335
Tubular Clip			013-028002
Shaft			020-037238
Wire Guide			045-030169
Over Center Spring			012-038938
Limit Spacer			044-030602
Flat Head Machine Screw			839-040214
Sems Round Head Machine Screw (Switch Mounting)			821-040314
Sems Round Head Machine Screw (Cancel Bracket Mounting)			821-040714

#### PEDAL SUSTAIN SWITCH ASSEMBLY 008-043872

Switch Panel and Bracket Assembly (String Bass I & II)			008-027679
Control Tab	STRING BASS I		031-034633

Control Tab	STRING BASS II	031-034634
Mounting Bracket		035-024205
Shaft		020-037240
Tubular Clip		013-028002
Lever Mounting Bracket		035-024335
Limit Spacer		044-030602
Flat Head Machine Screw		839-040214
Round Head Machine Screw		821-040314
Over Center Spring		012-038938
Resistor	1Meg R814	600-021211
Resistor	2.2Meg R812	600-021291
Resistor	8.2Meg R813	600-021431

#### LOWER PRESET SWITCH ASSEMBLY 008-043873

Switch Panel and Bracket Assembly (All 4 Same)		008-027674
Control Tab	DRAWBARS	031-037530
Control Tab	FLUTES / STRINGS 8'	031-043452
Control Tab	TIBIAS 8'	031-037532
Control Tab	ENSEMBLE 8'	031-043453
Cancel Linkage Assembly		060-037190
Mounting Bracket		036-024205
Lever Mounting Bracket		035-024335
Tubular Clip		013-028002
Shaft		020-037238
Wire Guide		045-030169
Round Head Machine Screw		821-040314
Flat Head Machine Screw		839-040214
Limit Spacer		044-030602
Over Center Spring		012-038938

#### LESLIE SWITCH ASSEMBLY 008-043874

Switch Panel and Bracket Assembly (On Upper and On Lower)		008-034548
Switch Panel and Bracket Assembly (Leslie Chorus)		008-027672
Switch Panel and Bracket Assembly (Leslie Fast)		008-027671
Control Tab	LESLIE ON UPPER	031-043462
Control Tab	LESLIE ON LOWER	031-043463
Control Tab	LESLIE CHORUS	031-043464
Control Tab	LESLIE FAST	031-043465
Mounting Bracket		035-024205
Lever Mounting Bracket		035-024335
Tubular Clip		013-028002
Shaft		020-037238
Limit Spacer		044-030602
Round Head Machine Screw		821-040314
Flat Head Machine Screw		821-040214
Over Center Spring		012-038938

#### REVERBERATION SWITCH ASSEMBLY 008-043875

Switch Panel and Bracket Assembly (Reverb I)		008-027670
Switch Panel and Bracket Assembly (Reverb II)		008-027673
Switch Panel and Bracket Assembly (Leslie on Reverb)		008-027672
Control Tab	REVERB I	031-034637
Control Tab	REVERB II	031-034638
Control Tab	LESLIE ON REVERB	031-043450
Mounting Bracket		035-024205
Lever Mounting Bracket		035-024335
Shaft		020-037238
Limit Spacer		044-030602

Tubular Clip				013-028002
Over Center Spring				012-038938
Flat Head Screw				839-040214
Round Head Screw				821-040314
Resistor	12K	R817		600-020751
Resistor	56K	R819		600-020911
Resistor	1K	R818		600-020491
Capacitor Ceramic	.02 mfd	C802		425-010572

**LOWER MANUAL ASSEMBLY 119-000050**

**UPPER MANUAL ASSEMBLY 119-000051**

Left Hand End Block				025-043984
Right Hand End Block				025-035707
Bracket and Key Channel Assembly (All Same)				060-033392
Sharp Key (Black)				025-032672
Natural Key (Ivory)	"C"			025-042279
Natural Key (Ivory)	"D"			025-042280
Natural Key (Ivory)	"E"			025-042281
Natural Key (Ivory)	"F"			025-042282
Natural Key (Ivory)	"G"			025-042283
Natural Key (Ivory)	"A"			025-042284
Natural Key (Ivory)	"B"			025-042285
Natural Key (Ivory)	"CX" (Last Key on Manual)			025-042286
Key Comb 12 Keys				057-037989
Key Comb 13 Keys				057-037990
Screw (For Mounting Keys to Channel)				850-000002

**GENERATOR AND MOTOR ASSEMBLY**

Generator Assembly	120v	60Hz			112-000040
Generator Assembly	120v	50Hz			112-000041
Generator Assembly	220v	60Hz			112-000042
Generator Assembly	220v	50Hz			112-000043
Synchronous Motor	120v	60Hz			021-033801
Synchronous Motor	120v	50Hz			021-033802
Synchronous Motor	220v	60Hz			021-033803
Synchronous Motor	220v	50Hz			021-033804
Motor Capacitor	120v	60Hz			499-033806
Motor Capacitor	120v	60Hz	or	120v 50Hz	499-033807
Motor Capacitor	220v	60Hz	or	220v 50Hz	499-033805
Generator Cover Assembly					115-000001
Terminal Panel Assembly (AC Panel With GY. BL. YEL.)					006-024326
Motor Mounting Bracket					035-027354
Capacitor Clamp					013-024313
Motor Clamp					013-024427
Motor Coupling Spring					012-029132
Motor Coupler					017-024242
Insulator Strip (AC Panel)					036-024328
Post (For Mounting Cover)					044-031434
Terminal Cover					041-022076
Oval End Cap (Motor Capacitor)					041-024838

**PREAMPLIFIER BOARD ASSEMBLY 124-000161**

Printed Wiring Board					023-044291
Resistor	82Ω	R409,437			600-220231
Resistor	820Ω	R405, 433			600-220471
Resistor	1000Ω	R401, 410, 424, 438, 454			600-220491
Resistor	1500Ω	R426, 446			600-220531

Resistor	4700Ω	R406, 418, 434, 439	600-220651
Resistor	8200Ω	R402, 430	600-220711
Resistor	10K	R408, 411, 414, 436, 453	600-220731
Resistor	15K	R425, 445	600-220771
Resistor	22K	R416, 424, 444	600-220811
Resistor	33K	R449	600-220851
Resistor	47K	R419, 428, 440, 448	600-220891
Resistor	56K	R452	600-220911
Resistor	68K	R450	600-220931
Resistor	82K	R412	600-220951
Resistor	100K	R420, 424, 432, 441, 455	600-220971
Resistor	180K	R413	600-221031
Resistor	220K	R451	600-221051
Resistor	270K	R415, 423, 443	600-221071
Resistor	330K	R422	600-221091
Resistor	390K	R 431, 433	600-221111
Resistor	470K	R417, 421, 442	600-221131
Capacitor Mylar	.1mfd	C411	412-110522
Capacitor Mylar	.22mfd	C406, 407, 425	412-110532
Capacitor Ceramic	.001mfd	C408, 410	426-010502
Capacitor Ceramic	.0022mfd	C407	426-010582
Capacitor Ceramic	.0033mfd	C403, 418	426-010622
Capacitor Ceramic	.0039mfd	C409	426-010642
Capacitor Ceramic	.0047mfd	C401, 416	426-010662
Capacitor Tantalum	1mfd 25v	C402, 417	414-040092
Capacitor Electrolytic	1mfd 25v	C412, 414, 422	407-060449
Capacitor Electrolytic	8mfd 25v	C404, 419, 426	407-060419
Capacitor Electrolytic	10mfd 15v	C413, 415, 421, 423	407-040429
Capacitor Electrolytic	500mfd 3v	C405, 420	407-010279
Potentiometer	5K	R427, 447	676-000011
Potentiometer	50K	R407, 435	676-000019
Transistor	Q401, 404, 406, 409		001-021070
Transistor	Q 402, 403, 405, 407, 408, 410, 411		001-021133
Master Oscillator Coil	1000mh	L401	003-043232

#### CYMBAL/BRUSH BOARD ASSEMBLY 124-000020

Printed Wiring Board			023-032934
Pin Connector			007-028499
Resistor	47Ω	R905, 916	600-020171
Resistor	390Ω	R920	600-020391
Resistor	10K	R907, 918	600-020731
Resistor	100K	R902, 909	600-020971
Resistor	220K	R911	600-021051
Resistor	1Meg	R901, 910, 912, 914	600-021211
Resistor	2.2Meg	R908	600-021291
Resistor	3.3Meg	R904	600-021331
Resistor	3.9Meg	R903	600-021351
Resistor	5.6Meg	R915	600-021391
Resistor	150Ω	R919	600-020291
Resistor	6.8Meg	R921	600-021411
Capacitor, Mylar	.01mfd 100v	C901, 904, 906, 907, 908, 911, 912, 914	413-110072
Capacitor, Mylar	.1mfd 100v	C910	413-110142
Capacitor, Mylar	.33mfd 100v	C909	413-110172
Capacitor, Mylar	.05mfd 100v	C902	413-110212
Capacitor, Disc	.00068mfd	C903	426-010462
Capacitor, Disc	.0047mfd	C905	426-010663
Capacitor, Electrolytic	80mfd 25v	C913	407-060259
Potentiometer	50K	R906, 917	676-000019

Potentiometer	250K	R913	676-000027
Potentiometer	20K	R922	676-000015
Coil Assembly	L901, 902		003-030753
Filter Choke Assembly	L903		003-027183
Diode	D901, 902, 904, 905		001-026010
Transistor	Q901		001-021133
Transistor	Q902, 905, 906		001-021134
Transistor	Q903		001-021135
Noise Transistor	Q904 (Clip Collector Lead)		001-021211

### POWER AMPLIFIER BOARD ASSEMBLY 124-000162

Printed Wiring Board			023-041224
Pin (P.W. Board)			007-028499
Resistor	2.2 $\Omega$	R26, 28, 61, 63	600-021521
Resistor	27 $\Omega$	R34, 69	600-020111
Resistor	47 $\Omega$	R24, 59	600-020171
Resistor	100 $\Omega$	R18, 20, 52, 70	600-020251
Resistor	330 $\Omega$	R21, 56	600-020371
Resistor	390 $\Omega$	R1	600-020391
Resistor	1200 $\Omega$	R22, 57	600-020511
Resistor	3300 $\Omega$	R46	600-020611
Resistor	4700 $\Omega$ 5%	R25, 60	600-020652
Resistor	5600	R4, 37	600-020671
Resistor	10K	R7, 40	600-020731
Resistor	12K	R15	600-020751
Resistor	15K	R13, 44	600-020771
Resistor	22K	R19, 54	600-020811
Resistor	27K	R12, 43	600-020831
Resistor	33K	R3, 36	600-020851
Resistor	68K	R8, 16, 41, 51	600-020931
Resistor	150K	R5, 38	600-021011
Resistor	270K	R11, 42	600-021071
Resistor	470K	R9	600-021131
Resistor	820K	R17, 53	600-021191
Resistor	3.3Meg	R2, 35	600-021331
Resistor	1500 $\Omega$	R14, 45	600-020531
Resistor	22 $\Omega$ 1Watt	R32, 67	600-030091
Resistor	330 $\Omega$ 1Watt	R33, 68	600-030371
Resistor	120 $\Omega$ 1Watt	R55	600-020271
Resistor	.47 $\Omega$ 2Watt	R30, 31, 65, 66	600-040021
Resistor	150 $\Omega$ 2Watt	R23, 58	600-040041
Resistor	390 $\Omega$ 5% 3Watt	R27, 29, 62, 64	600-050092
Capacitor Ceramic	47pf	C6	426-010172
Capacitor Ceramic	100pf	C9, C22	426-010252
Capacitor Mylar	.33mfd	C25	412-110552
Capacitor Mylar	.1mfd	C20	412-110142
Capacitor Mylar	.22mfd	C4, 5, 12, 15, 16	413-110162
Capacitor Tantalum	.33mfd	C7	414-040042
Capacitor Electrolytic	1mfd 25v	C2, 13	407-060449
Capacitor Electrolytic	100mfd 3v	C10, 23	407-010369
Capacitor Electrolytic	800mfd 25v	C8, 21, 24	407-060289
Capacitor Electrolytic	100mfd 15v	C1	407-040299
Capacitor Electrolytic	500mfd 25v	C11	407-060399
Transistor	Q1, 2, 6, 7		001-021070
Transistor	Q3, 4, 8, 9, 10		001-021133
Transistor	Q5, 11		001-021110
Heat Sink			041-028952

**ACTIVE FILTERS BOARD ASSEMBLY 124-000135**

Printed Wiring Board			023-043978
Pin (P.W. Board)			007-028499
Resistor	390Ω	R2	600-220391
Resistor	820Ω	R19	600-220471
Resistor	1000Ω	R1, 6, 8, 11, 12, 14, 24	600-220491
Resistor	10K	R3, 4, 5, 9, 10	600-220731
Resistor	12K	R15	600-220751
Resistor	15K	R18	600-220771
Resistor	22K	R22	600-220811
Resistor	27K	R20	600-220831
Resistor	33K	R7	600-220851
Resistor	47K	R17	600-220891
Resistor	56K	R13	600-220911
Resistor	100K	R16	600-220971
Resistor	220K	R23	600-221051
Resistor	270K	R21	600-221071
Capacitor Mylar	1mfd	C1, 2	406-010292
Capacitor Mylar	.22mfd	C8, 9	413-110162
Capacitor Mylar	.39mfd	C6	413-110382
Capacitor Mylar	.1mfd	C3	413-110142
Capacitor Electrolytic	1mfd	25v C7	407-060449
Capacitor Tantalum	3.3mfd	10v C5	414-240122
Capacitor Electrolytic	10mfd	15v C4	407-040429
Capacitor Electrolytic	100mfd	50v C10	407-080069
Transistor	Q1, 3, 5		001-021133
Transistor	Q2, 4		001-021172

**HARP SUSTAIN KEYSER ASSEMBLY 124-000163**

Harp Keyer Board Assembly (2 Used)			124-000046
Printed Wiring Board			023-039576
Pin (PWB)			007-028499
Resistor	47K	R502	600-220891
Resistor	1K	R504	600-220491
Resistor	10K	R503	600-220731
Resistor	2.2K	R501	600-220571
Capacitor Electrolytic	15mfd	20v C501, 502	407-050169
Transistor	Q501		001-021133
Harp Keyer Board Assembly (2 Used)			124-000047
Printed Wiring Board			023-039576
Pin (PWB)			007-028499
Resistor	47K	R502	600-220891
Resistor	1K	R504	600-220491
Resistor	10K	R503	600-220731
Resistor	2.2K	R501	600-220571
Capacitor Electrolytic	15mfd	20v C501	407-050169
Capacitor Electrolytic	8mfd	25v C502	407-060129
Transistor	Q501		001-021133
Harp Keyer and Preamp Board Assembly			124-000165
Printed Wiring Board			023-039579
Resistor	330Ω	R525	600-020371
Resistor	470Ω	R541	600-020411
Resistor	1K	R504	600-020491
Resistor	1.5K	R513, 529	600-020531
Resistor	2.2K	R501	600-020571
Resistor	4.7K	R516, 521	600-020651
Resistor	6.8K	R511, 512, 514	600-020691
Resistor	10K	R503, 526	600-020731

Resistor	39K	R515	600-020871
Resistor	47K	R502	600-020891
Resistor	68K	R524	600-020931
Resistor	150K	R523, 528	600-021011
Resistor	180K	R531	600-021031
Resistor	220K	R527	600-021051
Resistor	470K	R522	600-021131
Resistor	2.7K	R517, 540	600-020592
Resistor	33Ω	R518	600-020132
Capacitor Mylar	.068mfd	C521	406-010122
Capacitor Mylar	.1mfd	C513, 524	406-010142
Capacitor Mylar	.01mfd	C511	413-110072
Capacitor Mylar	.02mfd	C525	406-010182
Capacitor Electrolytic	100mfd	3v C523	407-010029
Capacitor Electrolytic	2mfd	25v C522	407-060109
Capacitor Electrolytic	8mfd	25v C502	407-060129
Capacitor Electrolytic	15mfd	20v C501	407-050169
Capacitor Ceramic	3900pf	C512	425-010642
Potentiometer (Harp Level)	20K	R530	676-000015
Transistor	Q501, 521, 522		001-021133

**PEDAL BOARD ASSEMBLY 063-044315**

**SINE WAVE AMPLIFIER BOARD ASSEMBLY NO. 1 124-000139**

Printed Wiring Board			023-044000
Connector and Terminal Assembly (6 pin)			005-043888
Connector and Terminal Assembly (3 pin)			005-043889
Printed Network (Sine Wave Amplifier)			058-043890
Capacitor Tantalum	1mfd	25v C618, 619, 625, 626, 627, C628, 629, 630, 631, 632, 633, 634, 635, 636	414-040092
Capacitor Tantalum	6.8mfd	10v C606	414-020142
Capacitor Tantalum	2.2mfd	10v C617	414-020112
Capacitor Tantalum	4.7mfd	10v C607, 608	414-020132

**SINE WAVE AMPLIFIER BOARD ASSEMBLY NO. 2 124-000154**

Printed Wiring Board			023-044001
Connector and Terminal Assembly (6 pin)			005-043888
Connector and Terminal Assembly (3 pin)			005-043889
Printed Network (Sine Wave Amplifier)			058-043890
Capacitor Tantalum	1mfd	25v C620, 621, 622, 623, 624, 637	414-040092
Capacitor Tantalum	3.3mfd	10v C610, 611, 612, 613, 614, 615	414-020122
Capacitor Tantalum	4.7mfd	10v C609	414-020132
Capacitor Tantalum	6.8mfd	10v C601, 602, 603, 604, 605	414-020142
Capacitor Tantalum	2.2mfd	10v C616	411-020112

**PEDAL KEYS BOARD ASSEMBLY NO. 1 124-000138**

Printed Wiring Board			023-043997
Connector and Terminal Assembly (6 pin)			005-043888
Connector and Terminal Assembly (3 pin)			005-043889
Printed Network 16'			058-043892
Printed Network 8'			058-044216

**PEDAL KEYS BOARD ASSEMBLY NO. 2 124-000153**

Printed Wiring Board			023-043997
Connector and Terminal (6 pin)			005-043888
Connector and Terminal Assembly (3 pin)			005-043889
Printed Network 16'			058-043892
Printed Network 8'			058-044214
Printed Network 8'			058-044215

**PEDAL PREAMPLIFIER BOARD ASSEMBLY 124-000137**

Printed Wiring Board			023-043993
Connector and Terminal Assembly (6 pin)			005-043888
Connector and Terminal Assembly (3 pin)			005-043889
Potentiometer	R615	250K	676-000027
Resistor	82Ω	R619	600-220231
Resistor	10K	R601, 603, 605, 606, 609, 610, 613, 617, 618	600-220731
Resistor	22K	R611	600-220811
Resistor	82K	R607	600-220951
Resistor	220K	R614	600-221051
Resistor	407K	R602, 608, 612, 616	600-221131
Resistor	1Meg	R604	600-221211
Capacitor Electrolytic	1mfd 25v	C651, 652, 656, 661	407-060449
Capacitor Electrolytic	2mfd 25v	C655	407-060479
Capacitor Electrolytic	500mfd	30v C662	407-070159
Capacitor Tantalum	.1mfd	25v C660	414-040012
Capacitor Mylar	.1mfd	C653, 654	413-110142
Capacitor Mylar	.039mfd	C657	413-110332
Capacitor Polyester	.022mfd	C658, 659	412-110482
Transistor	Q601, 602, 603, 604		001-021133

**MASTER PEDAL BOARD ASSEMBLY 124-000136**

Friction Lockwasher Assembly ( 9 pin)	005-043885
Friction Lockwasher Assembly (12 pin)	005-043886
Friction Lockwasher Assembly (15 pin)	005-043887

**NOTE:** Friction lockwashers are the female plug connectors mounted to master board. These plugs are to be changed in the near future. The numbers for replacement purposes are:

( 9 pin)	005-044532
(12 pin)	005-044533
(15 pin)	005-044534

**PERCUSSION GATE AMPLIFIER ASSEMBLY 117-000001**

Chassis Pan		041-031510
Percussion Transformer and Plug Assembly	T101	063-038635
Wire and Plug Assembly	P103	011-031564
Mounting Clip (For PW Board)		025-031671
Potentiometer	100K R113	676-000105
Potentiometer	10K R112	676-000143
Percussion Gate Amplifier Board Assembly		124-000003
Printed Wiring Board and Pin Assembly		023-031523
Capacitor Mylar	1mfd 100v C104	420-010113
Capacitor Mylar	.02mfd 100v C107	413-010312
Capacitor Electrolytic	100mfd 50v C102	407-080069
Capacitor Electrolytic	500mfd 5v C108	407-010279
Capacitor Mylar	.1mfd 100v C101, 105	413-110142
Capacitor Mylar	.22mfd 100v C106	413-110162
Capacitor Tantalum	.1mfd 25v C103	414-040092
Resistor	820Ω R117	600-020471
Resistor	1K R120	600-020491
Resistor	1.2K R106	600-020511
Resistor	2.7K R101	600-020591
Resistor	6.8K R109	600-020691
Resistor	10K R104, 111, 118	600-020731



Resistor	15K	R110	600-020771
Resistor	47K	R102, 105, 107, 116	600-020891
Resistor	100K	R115, 121	600-020971
Resistor	82K	R108	600-020951
Resistor	150K	R103	600-021011
Resistor	330K	R114	600-021091
Resistor	82Ω 5%	R119	600-020232
Potentiometer	100K	R132	676-000023
Transistor	Q101, 103, 104		001-021070
Field Effect Transistor	Q102		001-027010

#### ALTERNATE PERCUSSION GATE AMPLIFIER ASSEMBLY 117-000002

Chassis Pan				041-031592
Two Primary Matching Transformer		T301		003-031605
Plug and Wire Harness Assembly				011-043670
Mounting Clips (PWB)				025-031671
Potentiometer	100K	R313, 323		676-000105
Potentiometer	10K	R312		676-000143
Alternate Percussion Gate AMP Board Assembly				124-000004
Printed Wiring Board and Pin Assembly				023-031604
Capacitor Mylar	1mfd	100v	C304	420-010113
Capacitor Electrolytic	100mfd	50v	C302	407-080069
Capacitor Electrolytic	500mfd	3v	C308	407-010279
Capacitor Mylar	.1mfd	100v	C301, 305, 312	413-010142
Capacitor Mylar	.22mfd	100v	C306	413-010162
Capacitor Tantalum	1mfd	25v	C303	414-040242
Capacitor Ceramic	.01mfd	500v	C310	425-010752
Capacitor Mylar	.02mfd	100v	C307	413-010312
Capacitor Tantalum	1mfd	25v	C311	414-040092
Resistor	10Ω	R334		600-020011
Resistor	82Ω	R319		600-020031
Resistor	220Ω	R329		600-020331
Resistor	470Ω	R326, 327, 336		600-020411
Resistor	820Ω	R317		600-020471
Resistor	1K	R320		600-020491
Resistor	1.2K	R306		600-020511
Resistor	2.7K	R301		600-020591
Resistor	6.8K	R309		600-020691
Resistor	10K	R304, 311, 318, 324, 328		600-020731
Resistor	56K	R331		600-020911
Resistor	15K	R310		600-020771
Resistor	47K	R302, 305, 307, 316, 333, 338		600-020891
Resistor	100K	R315, 321		600-020971
Resistor	82K	R308		600-020951
Resistor	180K	R325		600-020131
Resistor	150K	R303		600-021011
Resistor	330K	R314		600-021091
Resistor	120K 5%	R332		600-020992
Zener Diode	1Watt	10Volt	5% D303	001-023039
Diode (Silicon)	D301, 302			001-026010
Transistor	Q301, 303, 304			001-021070
Transistor	Q308, 309			001-021100
Transistor	Q305, 307, 310			001-021133
Field Effect Transistor	Q302			001-027010

#### REVERBERATION AMPLIFIER ASSEMBLY 117-000003

Chassis Pan				041-031306
Wire and Plug Assembly		P252		011-031524

Wire and Plug Assembly	P251			011-031525
Mounting Clip (For PW Board)				025-031671
Potentiometer	50K	R273		676-000103
Capacitor	.0022mf	C260 (Mounted Between Pins 8 & 9)		425-010582
Reverberation Amplifier Board Assembly				124-000007
Printed Wiring Board and Pin Assembly				023-031522
Capacitor Electrolytic	1mfd	25v	C252	407-060119
Capacitor Electrolytic	500mfd	25v	C254, 255	407-060399
Capacitor Mylar	.1mfd	100v	C251	413-110142
Capacitor Mylar	.22mfd	100v	C258, 259	413-110162
Capacitor Ceramic	2200pf	500v	C257	425-010582
Resistor	12 $\Omega$	R265		600-020031
Resistor	150 $\Omega$ 5%	R259, 262		600-020292
Resistor	390 $\Omega$	R272		600-020391
Resistor	820 $\Omega$	R270		600-020471
Resistor	1K	R254, 256		600-020491
Resistor	1.2K	R255		600-020511
Resistor	1.8K 5%	R258, 261		600-020522
Resistor	4.7K	R271		600-020651
Resistor	22K	R253, 267		600-020811
Resistor	47K	R252		600-020891
Resistor	100K	R269		600-020971
Resistor	330K	R268		600-021091
Resistor	1Meg	R251		600-021211
Resistor	2.7 $\Omega$	R264		600-021531
Resistor	5.6 $\Omega$	R260, 263		600-021571
Transformer Assembly	T251			003-030865
Heat Sink				041-028952
Transistor	Q257			001-021070
Transistor	Q254, 255			001-021111
Transistor	Q258			001-021133
Transistor	Q251, 252			001-021134

#### PERCUSSION AND REITERATION DRIVE ASSEMBLY 128-000001

Chassis Pan				041-031549
Miniature Terminal Strip Assembly	5 Lug			006-031552
Miniature Terminal Strip Assembly	12 Lug			006-031553
Filter Choke Assembly	L201			003-037670
Potentiometer (Dual Construction)	R217, 218 Dual	500K		676-000267
Shake Proof Lockwasher				999-000801
Capacitor	.1mfd		C201	413-010142
Capacitor Tantalum	1mfd	25v	C203	414-040092
Resistor	3300 $\Omega$	5%	R216	600-020612
Resistor	22 $\Omega$		R209	600-020091
Resistor	470 $\Omega$		R214	600-020411
Resistor	2700 $\Omega$	5%	R213	600-020592
Resistor	3300 $\Omega$		R218 (Part of Brush and Cymbal Circuit)	600-020611
Resistor	10K		R201, 204, 215	600-020731
Resistor	15K		R208	600-020771
Resistor	33K		R206	600-020851
Resistor	47K		R205, 219, 220 (On Control for Brush and Cymbal)	600-020891
Resistor	100K		R202, 207	600-020971
Resistor	220K		R203	600-021051
Resistor	100K	5%	R212	600-020972
Transistor	Q201, 202, 203, 204, 205, 206, 207			001-021135
Silicon Control Switch	D205			001-026050
Zener Diode	D201			001-023033
Diode	D202, 204			001-026010
Wire and Plug Assembly				011-031555

**POWER AMPLIFIER ASSEMBLY 126-000066**

Chassis Assembly Riveted				009-043894
Transistor Heat Sink (For output Transistors)				041-041056
AC Cord and Plug Assembly				011-033233
Strain Relief (For AC Cord)				013-034994
Teflon Insulators (For Heat Sinks)				036-032018
Power Transformer and Pin Assembly T-702 (120v 60Hz Music Light)				003-044242
Power Transformer and Pin Assembly (120v/240v 50-60Hz Music Light)				003-044243
Power Transformer	120v 60Hz	T-701		003-044236
Power Transformer	120/220v 50/60Hz			003-044240
Transformer	T703	Main Channel		003-030905
Transformer	T704	Leslie Channel		003-042899
Power Transistor (4 used in Output)				001-012050
Silicon Compound (Apply to Power Transistors)				097-029624
Insulator (For Mounting Power Transistors)				036-030552
Relay (For Leslie)				003-031191
Relay Insulator				036-031018
Potentiometer	1K	R704		676-000107
Silicon Rectifier	D701 thru D708, D712, 713			001-024051
Diode Zener	22volts 10%	D711		001-023031
Diode	D709, 710			001-026010
Capacitor Electrolytic	3800mfd 50v	C704		450-080040
Capacitor Electrolytic	4000mfd 35v	C702		450-010081
Capacitor Electrolytic	4000mfd 35v (Sleeve)	C703		450-010082
Capacitor Electrolytic	100mfd 50v	C706, 707, 708, 709		407-080069
Capacitor Electrolytic	500mfd 40v	C705		407-090329
Capacitor Paper Mylar	.1mfd 600v	C710, 711		419-040052
Capacitor Ceramic	.02mfd 1000v	C701, 701A, 712		425-020770
Resistor Wire Wound	1 Ohm 2Watt	R703		601-040092
Resistor	470Ω	R701, R702		600-020411
Resistor	2700Ω	R709		600-020591
Resistor	3900Ω	R706		600-020631
Resistor	47Ω	R712		600-020171
Resistor	4700Ω	R705		600-020651
Resistor	6800Ω	R708		600-020691
Resistor	10K	R710, 711		600-020731
Resistor	22K	R707		600-020811
Power Transistor Regulator	Q701			001-021180
Transistor	Q702			001-021100
Power Amplifier Board Assembly				124-000162
Active Filters Board Assembly				124-000135

**SWELL PEDAL BOARD ASSEMBLY 124-000126**

Printed Wiring Board				023-043029
Miniature Pin Terminal (20 Used)				007-031196
Resistor	12K	R4, 4A, 4B, 4C		600-220751
Resistor	68K	R1, 1A, 1B, 1C		600-220931
Resistor	33K	R2, 2A, 2B, 2C		600-220851
Resistor	390Ω	R3, 3A, 3B, 3C		600-220391
Capacitor	.22mfd	C2, 2A, 2B, 2C		412-110532
Capacitor Ceramic	33pf	C1, 1A, 1B, 1C		426-010132

**WOODWORK**

Cabinet Assembly	R-124			111-000118
Cabinet Assembly	R-182			111-000117
Cabinet Assembly	R-195			111-000120
Case Assembly	R-124			050-001900
Case Assembly	R-182			050-001800

Case Assembly	R-195	050-002200
Top Panel	R-124	050-001934
Top Panel	R-182	050-001835
Top Panel	R-195	050-002220
Music Panel	R-124	050-001943
Music Panel	R-182	050-001839
Music Panel	R-195	050-002223
Rear Cover	R-124, R-182, R-195	056-043949
Baffle and Grille Cloth	R-124	052-043931
Baffle and Grille Cloth	R-182	052-043933
Baffle and Grille Cloth	R-195	052-043934
Bench Assembly	R-124	152-000050
Bench Assembly	R-182	152-000049
Pedal Keyboard Assembly	R-182, 124, 195	153-000017
Swing Out Wood Panel		050-001856
Harp Keyer Rack		050-040261

### MISCELLANEOUS

Rotary Tremolo Assembly	120/60	121-000124
Rotary Tremolo Assembly	120/50	121-000125
Rotary Tremolo Assembly	220/50	121-000127
Bass Speaker 15"	4.0 Ohms	014-044213
Treble Speaker 8"	8.0 Ohms	014-028677
Hand Lift Assembly		060-043865
Phone Jack Assembly (Stereo)		008-044229
Pedal Switch Assembly		116-000027
Pedal Switch (25 Used)		008-030134
Reverb Unit Assembly		121-000128
Swell Pedal Assembly		116-000027
Photocell Housing Cover		025-032483
Shutter		041-043035
Photoconductive Cell (2 Used)		040-043387
Diffuser		016-030153
Light Bulb Socket and Pin Assembly		016-038542
Light Bulb (For Swell Pedal)		016-031748
Printed Wiring Board Assembly		124-000126
Top Cover Assembly (Rhythm II and Music Light)	R-124	125-000057
Top Cover Assembly (Rhythm II and Music Light)	R-182	125-000058
Top Cover Assembly (Rhythm II and Music Light)	R-195	125-000059
Lamp Holder (17 Used)		016-042766
Lamps (17 Used)	14v	016-031749
Rhythm II Unit		125-000049
Lens (Music Lamp) Upper Lens		026-043744
Diffuser Lens Lower Lens		016-043749
Tempo Knob		031-042578
Embossed Logo		038-025935
Capacitor (Crossover Network)	C803 10mfd 50vNP	407-080269

### LESLIE TREMOLO UNIT (See Figure 6-1.)

Drive Belt, 60Hz	011700
Z Bracket, Stabilizing	014324
Motor Pulley, 50Hz	014704
Mercotac Rotary Contact	015941
Dual Contact - Mercotac	015958
Plug Housing, 6 Circuit Molex, Natural	023259
Contact, Insert, Male	023309
Motor Pulley, 60Hz	024307
Screw, Machine, 10-24 x 3/8", Round Head	025460

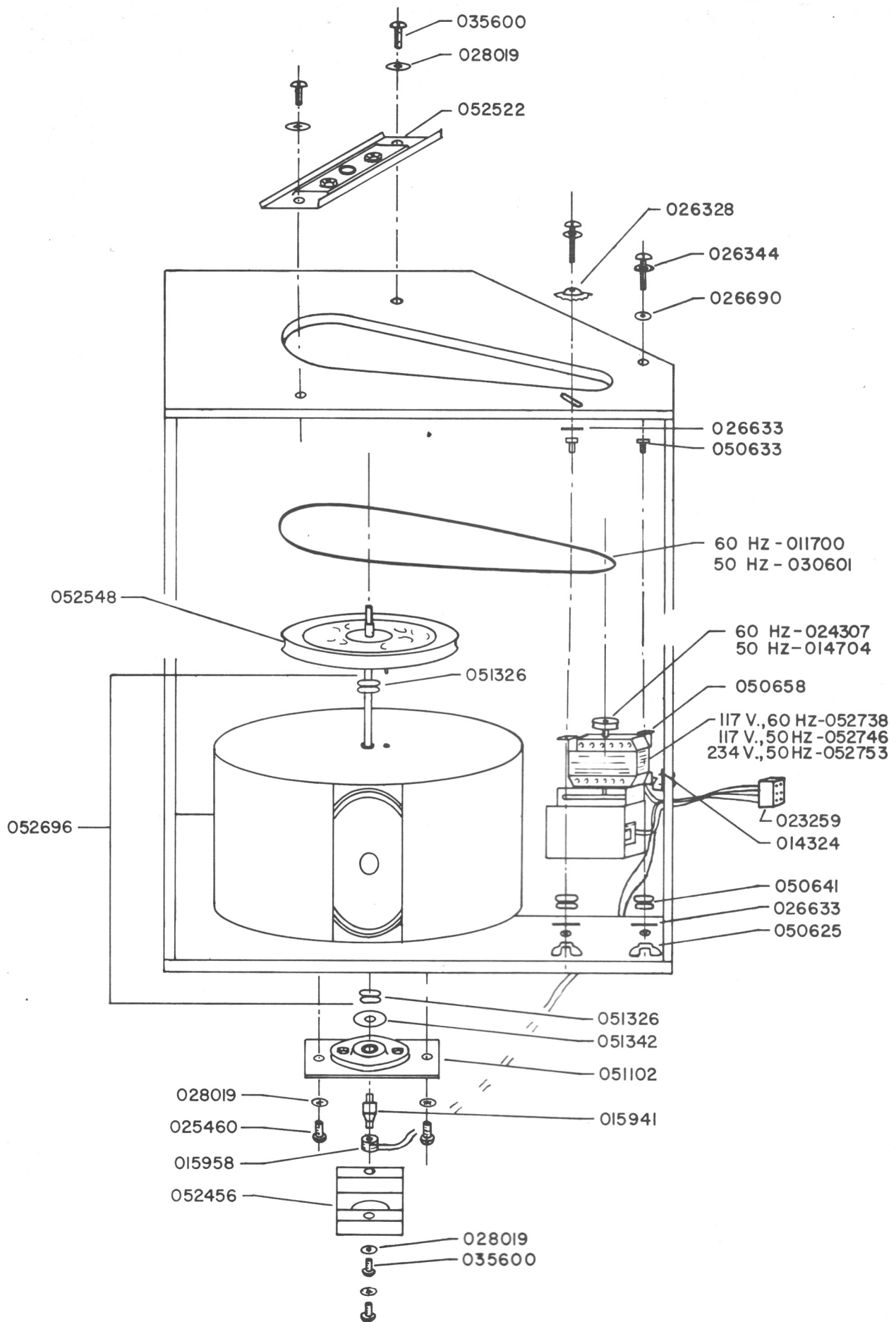

Figure 6-1. Location of Parts in Leslie Rotary Unit

Lockwasher, Domed, 1/4" x 1-1/8" x .040"	026328
Flat Washer, #10	026633
Screw, Machine, 10-24 x 1 1/2", Round Hd w/Int. Lockwasher	026344
Flat Washer, #10	026690
Lockwasher, Internal, #10	028019
Drive Belt, 50Hz	030601
Screw, Machine, 10-24 x 5/8", Round Head	035600
Wing Nut, 10-24	050625
Bushing, Shoulder	050633
Grommet, Z Motor Mount Bracket	050641
Z Motor Mount Bracket	050658
Bearing Assembly, Lower	051102
Drum Grommet	051326
Flat Washer, 5/16" x 7/8" x 5/64"	051342
Protective Bracket, Mercotac	052456
Bearing Assembly, Upper	052522
Shaft and Pulley Assembly	052548
Drum Assembly, w/ 6"x9", 8 Ohm Speaker	052696
Two Speed Motor Assembly, 117V, 60Hz	052738
Two Speed Motor Assembly, 117V, 50Hz	052746
Two Speed Motor Assembly, 234V, 50Hz	052753

