

# SERVICE MANUAL



## HAMMOND X-2 COMBO ORGAN

Create tone textures and sound with this new Hammond combo-size synthesis tonebar organ. It's ultra-light, compact and flexible. The X-2 can be used as a table-top organ, or placed on top of another organ and played through that organ's amp. Or it can be placed on its legs, hooked up to its swell (expression) pedal, plugged into an amplifier, and used as a separate instrument. The organ is tuneable: a single knob controls the pitch of all the notes simultaneously.

- One keyboard, 49 notes.
- Variable Pitch Control (Tuning).
- Nine harmonic tonebars.
- Synthesis Percussion with touch control.
- Four percussion harmonic tabs plus slow/fast decay and loud/soft tabs.
- Tibia and Brass Presets.
- Vibrato (3 degrees) and Delay Vibrato.
- Volume Control.
- Swell (Expression) Pedal.

SPECIFICATIONS: Weight: 44 lbs. • Dimensions: With legs: 34¼" W., 37" H., 23½" D.  
• Without legs: 34¼" W., 8" H., 18½" D.  
• Power Source: 115V, 60 cycle AC  
• Accessories: Legs, Swell (Expression) Pedal.

## **PRODUCT SERVICE**

For product service, contact nearest authorized Hammond Service Center or write to: Manager, Product Service, Hammond Organ Company, 4200 West Diversey Avenue, Chicago, Illinois 60639.

Parts are also Available by Contacting Product Service as Mentioned Above.

### **IMPORTANT:**

Always supply model designation and serial number when writing.

# TABLE OF CONTENTS

## SECTION I — HOW THE ORGAN OPERATES

1-1	General	1-1
1-2	Cabinetry	1-1
1-3	Tone Source	1-1
1-4	Manuals	1-1
1-5	Tone Bars	1-1
1-6	Presets	1-1
1-7	Percussion	1-1
1-8	Soft/Percussion/Loud	1-1
1-9	Vibrato	1-1
1-10	Delay Vibrato	1-2
1-11	Tuning Control	1-2
1-12	Volume	1-2
1-13	Brilliance	1-2
1-14	Expression Pedal	1-2

## SECTION II — DISASSEMBLY AND MAINTENANCE

2-1	General	2-1
2-2	Top Cover	2-1
2-3	Potentiometer	2-1
2-4	Rocker Tabs	2-1
2-5	Power Switch	2-1
2-6	Control Panel Assembly	2-1
2-7	Tone Bar Assembly	2-1
2-8	Front Strip	2-1
2-9	Printed Wiring Boards	2-1
2-10	Power Supply Assembly	2-1
2-11	Manual Assembly	2-1
2-12	Manual Keys	2-2
2-13	End Blocks	2-2
2-14	Expression Pedal	2-2

## MAINTENANCE AND SERVICE HINTS

2-17	Test and Adjustment Procedures	2-3
	Test and Adjustment Procedures	2-4

## SECTION III — DIAGRAMS AND TEXT

3-1	General	3-1
-----	---------	-----

## LIST OF ILLUSTRATIONS

Figure		
3-1	Console Logic Diagram	3- 2
3-2	M.D.D. Generator Board Schematic Layout and Theory (228-19213)	3- 3
3-3	M.D.D. Buffer Board Schematic Layout and Theory (223-35341)	3- 4
3-4	Divider, Layout and Theory (229-20317)	3- 5
3-5	Divider Board Schematic (229-20317)	3- 6
3-6	Mix Tone Board, Schematic Layout and Theory (232-11206)	3- 7
3-7	Pre Amp Board, Schematic Layout and Theory (219-51211)	3- 8
3-8	Percussion Board, Schematic Layout and Theory (223-35246)	3- 9
3-9	Power Supply Unit, Schematic and Layout (105-08205 & 224-14211)	3-10

## SECTION IV-ILLUSTRATED PARTS LIST

4-1	Index	4-1
-----	-------	-----



# SECTION I. HOW THE ORGAN OPERATES

## X-2 17050K

### 1-1 GENERAL

This section contains a brief description of the various sections of the instrument.

### 1-2 CABINETY.

The case work is wood frame and panels. The outer side is coated with vinyl leather. It has a leather-made handle for carrying, and a removal key cover.

### 1-3 TONE SOURCE

The 17050K utilizes the single master oscillator with the multi-derivative divider (MDD) system. The twelve I.C.'s mounted on the 229-20217 (DV-4A) Divider Board provide the division of outputs.

### 1-4 MANUAL

A 49-note Manual has ten contacts switched to ten common bus bars under each key. One of these contacts switches voltage for control of Percussion and Delay Vibrato, while the others switch signals from Tone Source directly.

### 1-5 TONE BARS

Tone Bars carry the footage markings and produce a variety of tones and loudness.

### 1-6 PRESETS

The two Presets (Rocker Tabs) may be used to select pre-set tones or Tone Bars. The presets have the following Tone Bar structure.

Preset	Tone Bars
Tibia	80 6808 006
Brass	84 8868 666

### 1-7 PERCUSSION

Percussion is switched on by the Rocker Tabs, which are SECOND HARMONIC, THIRD HARM., FOURTH HARMONIC and FIFTH HARMONIC, and each footage of the pitch corresponds to 4', 2 2/3', 2', and 1 3/5' of Tone Bars. Percussion only operates in Tone Bar settings (Preset off). It has two decay times, approximately 1.5 seconds (Slow) and 90 msec. (Fast).

### 1-8 SOFT/PERCUSSION/LOUD

This tab varies the Percussion's level. Loud is about 6 dB louder than Soft.

### 1-9 VIBRATO

A Master Oscillator Vibrato offers three widths at one speed which affects all voices.

Vibrato II is wider than I. The two tabs are additive, with the Vibrato being widest when both on. Vibrato rate is  $6.6 \pm 0.2$  Hz.

#### **1-10 DELAY VIBRATO**

When a key is played, Vibrato is delayed for approximately one second.

#### **1-11 TUNING CONTROL**

This knob is used for tuning the organ to other instruments. When the scale is in the center position, it is a normal pitch. Turn clockwise to raise the pitch, and counter clockwise to lower pitch.

#### **1-12 VOLUME**

This knob controls the overall volume of the organ soft to loud, and its variable range is about 30 dB.

#### **1-13 BRILLIANCE**

This tab has no effect up to 1000 Hertz, then gradually attains a slope of 6 dB per octave and alters the response about 8 dB at 5 KHz.

#### **1-14 EXPRESSION PEDAL**

The assembly is made of steel frame. The attenuator is a variable resistor.

The variable range is about 30 dB at 1000 Hz. In minimum position, its response is such that the level boosts about 6 dB at low (60 Hz) and high (8 KHz) frequencies.

## SECTION II. DISASSEMBLY AND MAINTENANCE

### 2-1 GENERAL

This section contains instructions for removal of specific assemblies of the organ. It is a step thru procedure and reassembly is in a reverse procedure. The removal of some sub-assemblies and unplugging connectors or unsolder is obvious. These will not be discussed.

### 2-2 TOP COVER

- A. Locate and loosen two (2) bronze screws from under side (bottom) of manual and case section. See figure 2-1 for location.
- B. Swing up top cover.

### 2-3 POTENTIOMETERS (Tuning & Volume)

- A. To remove from top side of cover, loosen small set screws in knob and remove knobs.
- B. Swing up top cover and from under side remove four (4) screws fastening potentiometers and bracket to top cover.
- C. With bracket loose, remove hex nut securing potentiometer to top cover. Reverse procedure for re-assembly.

### 2-4 ROCKER TABS (Removal)

- A. Remove five (5) screws mounting rocker tab assembly to top cover.
- B. With assembly loose, remove top and bottom screw of associated rocker tab switch. Tab and switch will lift out.

### 2-5 POWER SWITCH

- A. From under side of top cover, remove two (2) screws fastening fiber cover to switch assembly.
- B. Remove screw mounting switch to bracket. Switch now loose.

### 2-6 CONTROL PANEL ASSEMBLY

- A. With top cover raised, remove six (6) truss head screws mounting control panel to top cover assembly.
- B. Carefully lower control panel, avoid marring or damaging.

### 2-7 TONE BAR ASSEMBLY

With control panel lowered as in Step 2-6, remove four (4) screws mounting tone bar assembly to control panel. reassemble in reverse procedure.

### 2-8 FRONT STRIP

- A. Proceed as in Steps 2-2 and 2-6.
- B. Remove screws fastening front strip to top cover. Reverse procedure to reassemble.

### 2-9 PRINTED WIRING BOARDS

- A. (Under control panel)-To remove board, depress tab projection of plastic locking stud and lift carefully each corner of board. Replace by pressing down each corner of board against plastic stud which locks board into place.
- B. (Other Boards) Remove screws at each corner of board.

### 2-10 POWER SUPPLY ASSEMBLY

- A. Caution: Remove A.C. plug from outlet.
- B. Remove cover by removing two wood screws and two hex nuts securing cover remove cover.
- C. Remove long bronze screw by removing double hex nuts.
- D. Remove two (2) hex nuts mounting power chassis to case. Carefully lift out power supply assembly.

### 2-11 MANUAL ASSEMBLY

- A. See Figure 2-1 for location. Remove four (4) 1" long bronze screws for under side of manual and case section.
- B. Carefully lift manual and tilt back.

**2-12 TO REPLACE MANUAL KEYS**

- A. Follow Steps 2-2 and 2-11.
- B. Remove several locking springs holding plastic covered rod in area of key to be replaced.
- C. Remove key spring from rear of key channel.
- D. Lift rear of key channel slightly and in a forward motion. Carefully remove key and channel assembly from manual. In the removal of sharp (black) keys, it will be necessary to remove neighboring keys. Reassemble in reverse procedure.

NOTE-Key contact adjustment can be made by turning most forward screw on key and channel assembly in or out.

**2-13 END BLOCKS**

- A. Follow Steps 2-2 and 2-11.
- B. Remove screw, a wood screw at the rear of the end block.
- C. Remove another screw located under end block. Remove block.

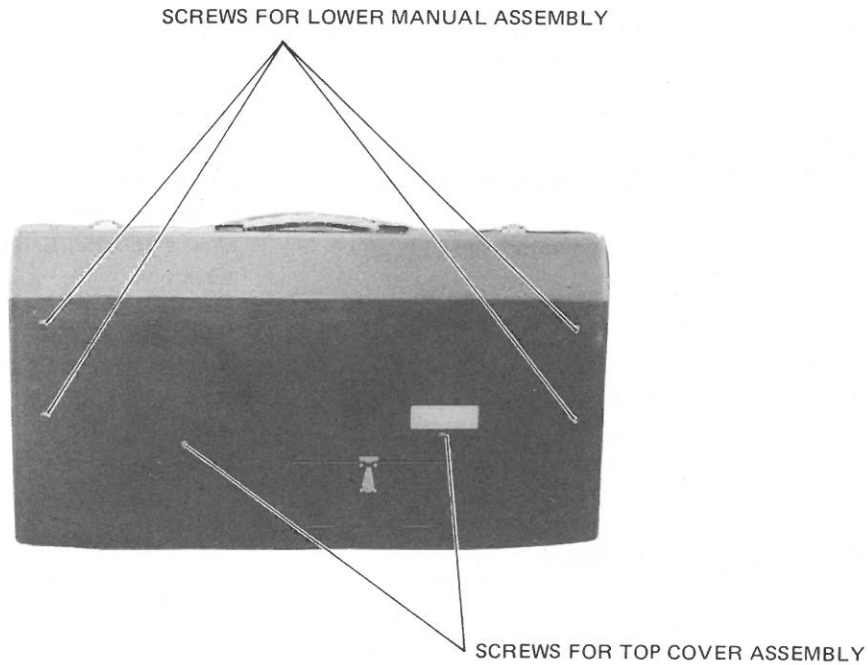

**2-14 EXPRESSION PEDAL ASSEMBLY**

- A. To remove pedal from the metal base. Rubber mat of pedal can be removed by lifting edges of mat. Mat will lift and peel off.
- B. With mat removed, remove four (4) screws holding metal pedal to base section and separate.

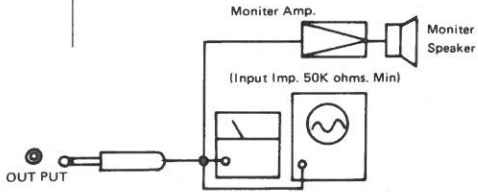
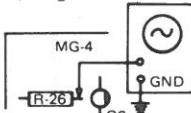

**FIGURE 2-1. BOTTOM VIEW**

TEST AND ADJUSTMENT PROCEDURES . . . MODEL 17050K

STEP	TEST & TEST POINT	DEPRESS TAB OR EXTEND TONE BAR	PLAY KEYS	ADJUST	OSCILLOSCOPE OR OTHER INDICATION
1	<p>PREPARATION</p> <p>Connect out put Terminal as Fig. 1</p> <p>Disconnect Expression Pedal until Indication</p>				 <p>Fig. 1</p>
2	<p>POWER SUPPLY</p> <p>(a) Terminals on PS-21 Board</p>			<p>GND-P1 (GRN) -13.5 ~ -14.5V D.C</p> <p>GND-P4 (BLU) -25.1 ~ -27.8V D.C</p> <p>GND-P6 (RED) +27 ~ +35 V D.C</p> <p>GND-P5 (ORN) +1.8 ~ +2.2 V D.C</p> <p>Note. ( ): Wire Color</p>	
3	<p>TUNING, SCALE, and VIBRATO OUT PUT</p> <p>(a)</p>	<p>(a) 1' Tone Bar Tuning Cont. Knob: Center</p> <p>(b) Tuning Knob: Max. (# Mark)</p> <p>(c) Tuning Knob: Min. (b Mark)</p>	<p>Key 46 (Highest "A")</p>	<p>(a) MG-4 Coil</p>	<p>7040 ± 10 Hz</p> <p>7400 to 7600 Hz</p> <p>6700 to 6900 Hz</p>
4	<p>VIBRATO</p> <p>(a-e) Fig. 2</p>  <p>Fig. 2</p>	<p>(a) Vibrato I &amp; II: ON</p> <p>(b)</p> <p>(c) Vibrato II: ON</p> <p>(d) Vibrato I: ON</p> <p>(e) Delay Vib.: ON</p> <p>Vibrato I &amp; II: ON</p>	<p>Any Key</p>	<p>(a) MG-4 VIB. SPEED</p> <p>(b) MG-4 VIB. DEPTH</p> <p>(e) MG-4 DELAY TIME</p>	<p>T: 152 msec.</p> <p>A: 4.0Vp-p  Fig. 3</p> <p>A: 2.0V ± 0.5V</p> <p>A: 1.0V ± 0.5Vp-p</p> <p>1.5 sec.  Fig. 4</p>
5	<p>OUTPUT LEVEL</p> <p>Out put to Monitor Amp &amp; Indications</p>	<p>Percussion: all OFF</p> <p>Brilliance: ON</p> <p>Preset: OFF</p> <p>(a) Tone Bar 16'</p> <p>(b) Tone Bar 5-1/3'</p> <p>(c) Tone Bar 8'</p> <p>(d) Tone Bar 4'</p> <p>(e) Tone Bar 2-2/3'</p> <p>(f) Tone Bar 2'</p> <p>(g) Tone Bar 1-3/5'</p> <p>(h) Fone Bar 1-1/3'</p> <p>(i) Tone Bar 1'</p> <p>( ) Preset: ON</p> <p>(j) Preset: Tibia</p> <p>(k) Preset: Brass</p>	<p>Key 13, 17, 20 (Chord C, E, G)</p>		<p>55-75 mVrms.</p> <p>57-77</p> <p>63-83</p> <p>40-54</p> <p>37-50</p> <p>32-43</p> <p>26-36</p> <p>26-36</p> <p>23-31</p> <p>73-95</p> <p>87-117</p>

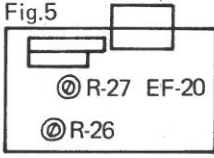
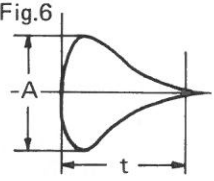
STEP	TEST & TEST POINT	DEPRESS TAB OR EXTEND TONE BAR	PLAY KEYS	ADJUST	OSCILLOSCOPE OR FIG. OTHER INDICATION
6	BRILLIANCE & FREQUENCY CHARACTERISTIC				
(a)	Output	Tone Bar 4' Brilliance OFF → ON	(a) 49 (Highest "C")		0 → +7.0 ± 1.5 dB
(b)		Brilliance OFF	(b) 37		-4.5 ± 1 dB: Note
(c)		Tone Bar 4'	(c) 49		-12 ± 2 dB: Note Note: Key 13 is 0 dB
7	Volume Control Output	Volume Knob Max → Min.			0 → -30 ± 3 dB
8	PERCUSSION Ear & Output	Tone Bar: all Min. Brilliance: ON Second. Harmo.: ON Perc. Soft/Loud → Loud	(a, b) 13		
(a)	Decay	Decay: Slow		Fig.5  EF-20 (R-26)	Fig.6  t: 1500 msec.
(b)	Level	Decay: Fast Decay: Slow Perc.: Soft Perc.: Loud		EF-20 (R-27)	t: 90 msec. Level 'A' is the same as Tone Bar 4' A: 200 ± 30mVpp
9	EXPRESSION Output & Ear				
(a)	Connect Exp. Pedal	Tone Bar 8' Exp. Pedal: Max	(a) 13		Level Drop With Exp. Pedal: 3.0 dB Max.
(b)	Exp. Variable Range	Brilliance: ON Tone Bar: 8'	(b) 13		28-34 dB
10	TOTAL NOISE Output & Ear	Exp. Vol: Max All Tabs: ON (Except Preset & Perc.) Tone Bar: all Max. Tone Bar: all Min.	Key OFF Key ON		.10mVrms Max. .13mVrms Max.



## SECTION III. DIAGRAMS AND TEXT

### 3-1 GENERAL.

This section contains schematic diagrams and text to illustrate and provide information necessary to proper organ servicing.

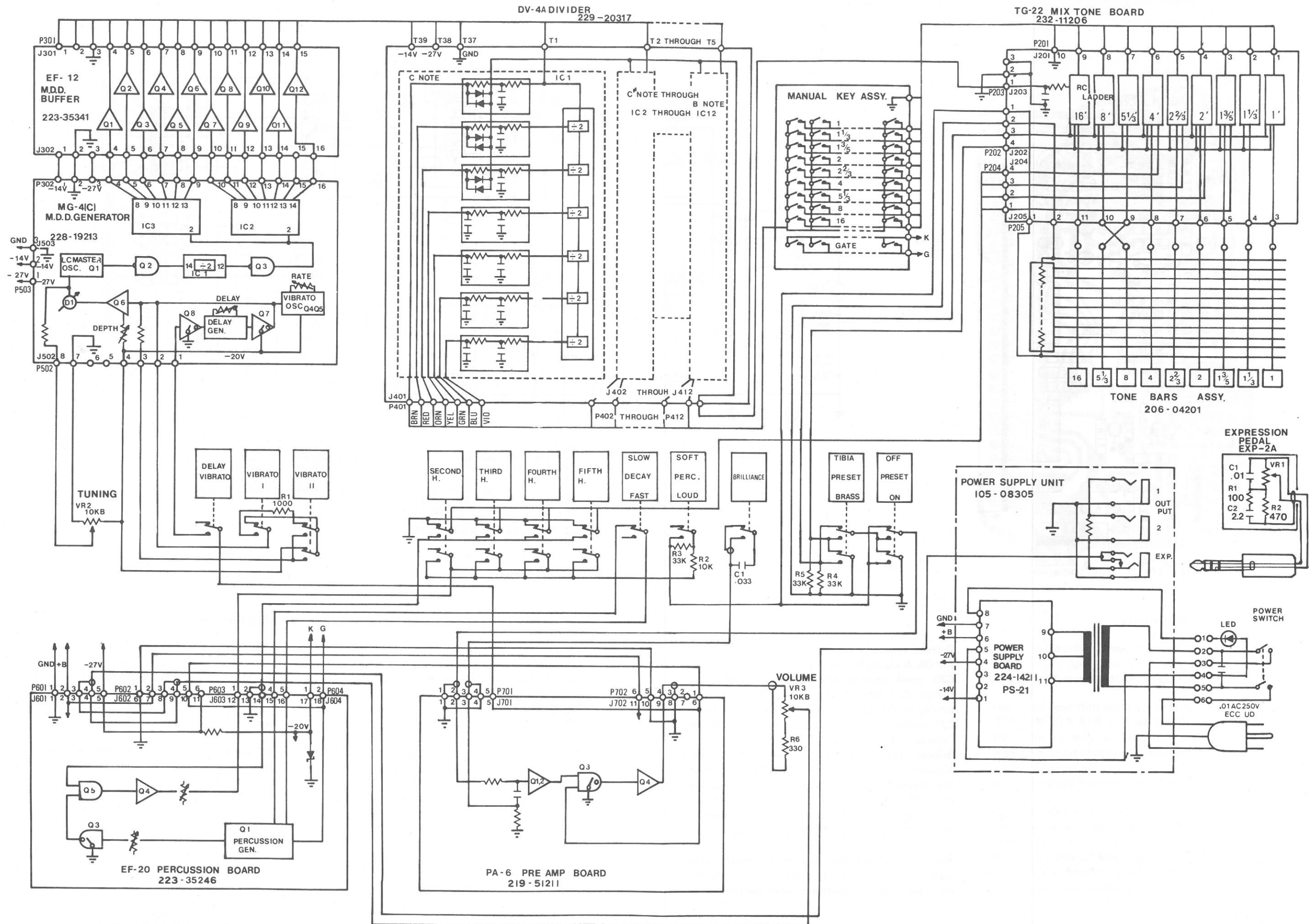
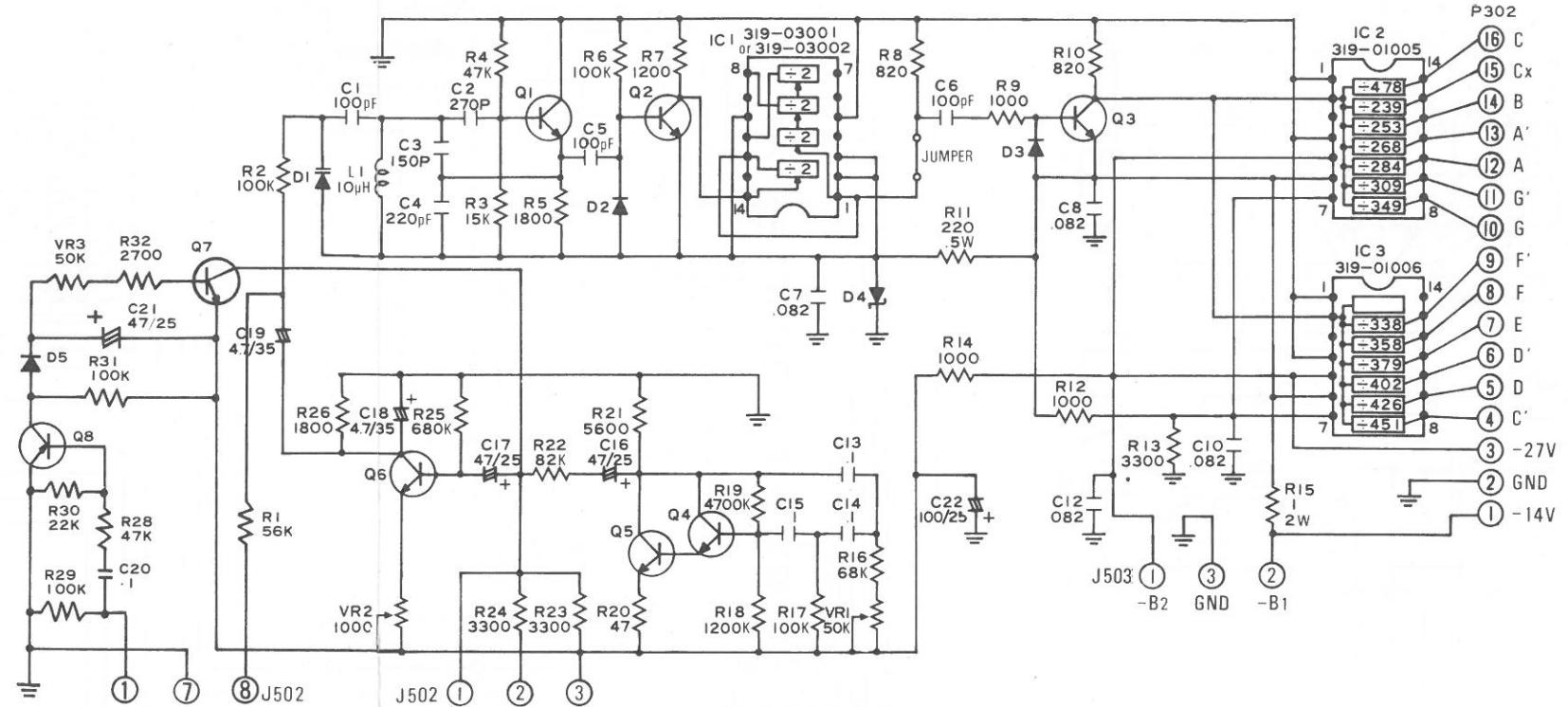
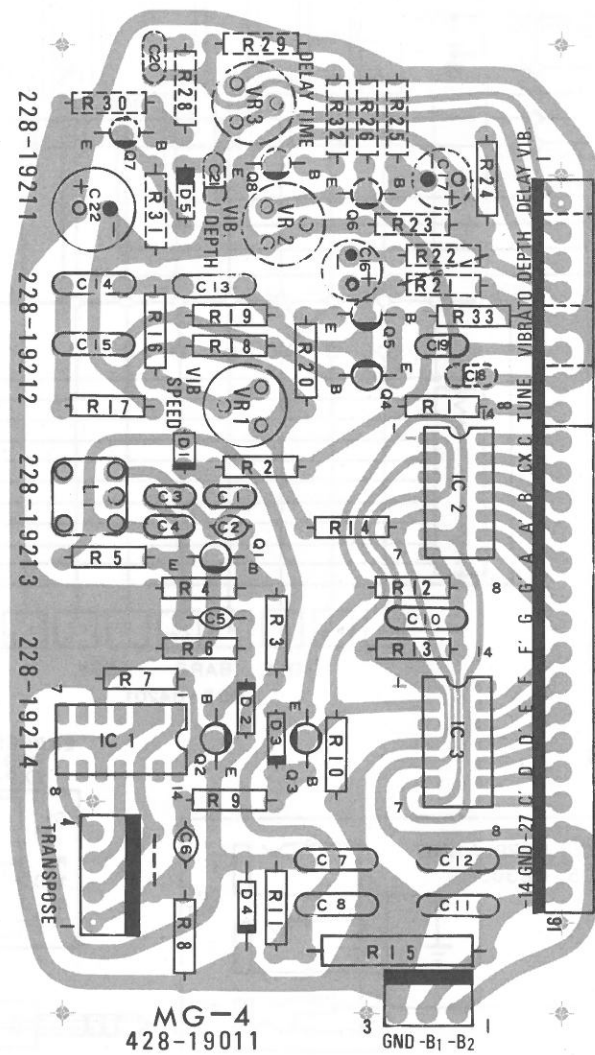

FIGURE 3-1  
LOGIC DIAGRAM 3-2





**\*NOTES**

- 1 IC1 319-03001 DM7493
- IC2 319-01005 MM5832
- IC3 319-01006 MM5833
- D1 306-05001 1S2206
- D2,D3 306-01017 1S2473
- D4 337-06014 RD-5.6EB
- Q1 305-03014 2SC373
- Q2 THROUGH Q6 305-03040 2SC945Q
- Q8 305-01009 2SA7330

- 2 UNLESS OTHERWISE SPECIFIED:  
ALL RESISTORS ARE IN OHMS, ±5%, 1/4WATT.  
ALL CAPACITORS ARE IN MICROFARADS.
- 3 ① SYMBOL DENOTES NUMBERS IN PLUG.

**LC Oscillator With Vibrato**

Assembly MG-4(C) includes a vibrato oscillator, delayed vibrato circuitry, and a high frequency LC oscillator used to drive the MDD generator.

The vibrato oscillator is a phase shift type, comprised of C13, C14, C15, R16, R17, R18, R19, R20, R21, VR1, Q4 and Q5. VR1 is used to adjust the oscillator's frequency. The vibrato signal is coupled through C16, R22, and C17 to the base of transistor Q6, where it is amplified (Its width being controlled by VR-2).

Vibrato may be turned off by connecting J502-2 to -20 volts (J502-4), and may be reduced for "Vibrato I or Vibrato II" by connecting R24 through J502-3 to -20 volts. To achieve a better sine wave the vibrato signal is filtered by C18 and is then coupled to the LC oscillator circuitry by C19.

Delayed vibrato is accomplished by transistors Q7 and Q8. A keying DC signal (-10 volts) is applied to C20, which turns on Q8 for about 10 msec.; this charges C21 through D5 to a ground potential, turning on Q7 for approximately 1.5 seconds (until C21 discharge). When Q7 is turned on, the collector "shorts" the vibrato signal to -27 volts, thus the delayed vibrato time is approximately 1.5 seconds. Adjustment of VR-3 decrease or increase the time of the delayed vibrato. The LC oscillator is comprised of L1, D1, C1, C2, C3, C4, R3, R4, R5, and Q1, and is a Colpitts type. D3, a varicap diode, is used to vary the oscillator's frequency for vibrato and tuning control; as the voltage at the junction of R2, C1, and D1 becomes more negative, the capacitance of the varicap diode increases, and the oscillator frequency decreases. Since the cathode of

the varicap is normally (with no vibrato) at ground potential and the anode is held at -5.6 volts by D4 and R11, the capacitance of the varicap remains constant, and stability of the oscillator is maintained. Capacitor C1 is used to isolate the DC bias on the varicap from the tank circuit. L1, with C3, C4, C1, and the varicap diode oscillate at 4.00048 MHz. R4 and R5 supply a bias voltage for Q1. The oscillator signal is coupled through C5 to buffer amplifier Q2 which drives IC-1. "Tuning" (Potentiometer 10 Kohms) is controlled by varying voltage of J502-8 from zero volt to -20 volts.

**MDD Generator**

IC1 is a signal divider; it is used to insure a square input signal with a 50 per cent duty cycle to drive the MDD IC packages. This divider (IC1) may be driven by the vibratoable oscillator. The -5 volts for this IC is generated by D4 and R11 and bypassed by C7.

IC2 and IC3 are the two frequency generators; IC2 generates frequencies of note "G" through "Cx" and "C". IC3 generates of note "C" through "F". IC1 drives buffer Q3, supplying an 11 volt 2.00024 MHz clock signal for the MDD packages.

FIGURE 3-2  
M.D.D. GENERATOR BOARD  
SCHEMATIC, LAYOUT AND THEORY  
MG-4C (228-19213)

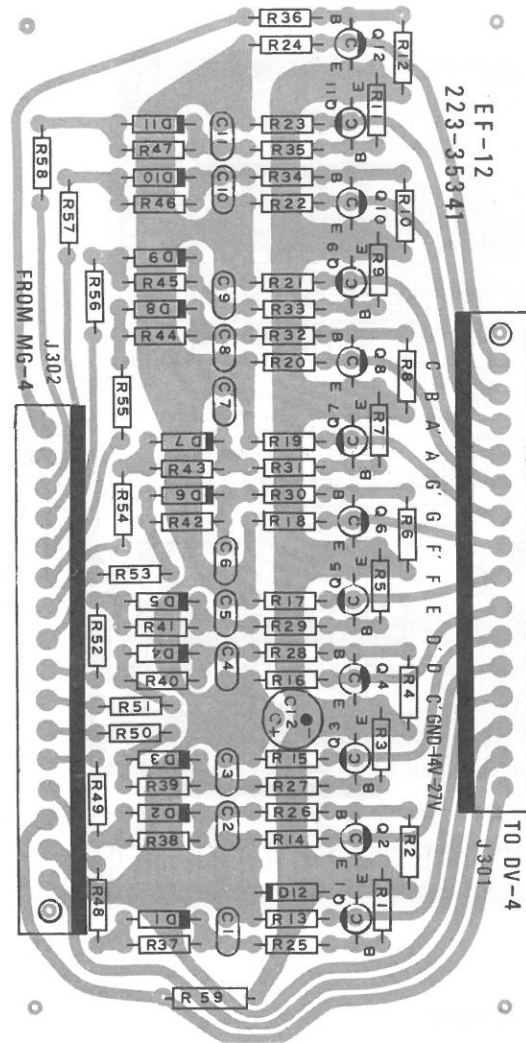

**EF-12 223-35341  
MDD BUFFER BOARD**

This board provides the clocks to drive the DV-4 Board, and which wave form are square and approximately 50% duty cycle.

There are 12 transistors located on this board, which are Q1 through Q12. The inputs of these transistors are connected through RC filters, but the input of Q12 is connected through resistor only, to the connector J302. These input form the MDD Generator Board come on J302 pin 4 through pin 16, but pin 15 is not used. These inputs' wave form are not 50% duty cycle, those are 30%-70% duty cycle, but "C" Note, pin 16, is 50% duty cycle. Those inputs are provided to RC time delay circuits. These time delay circuits provide the

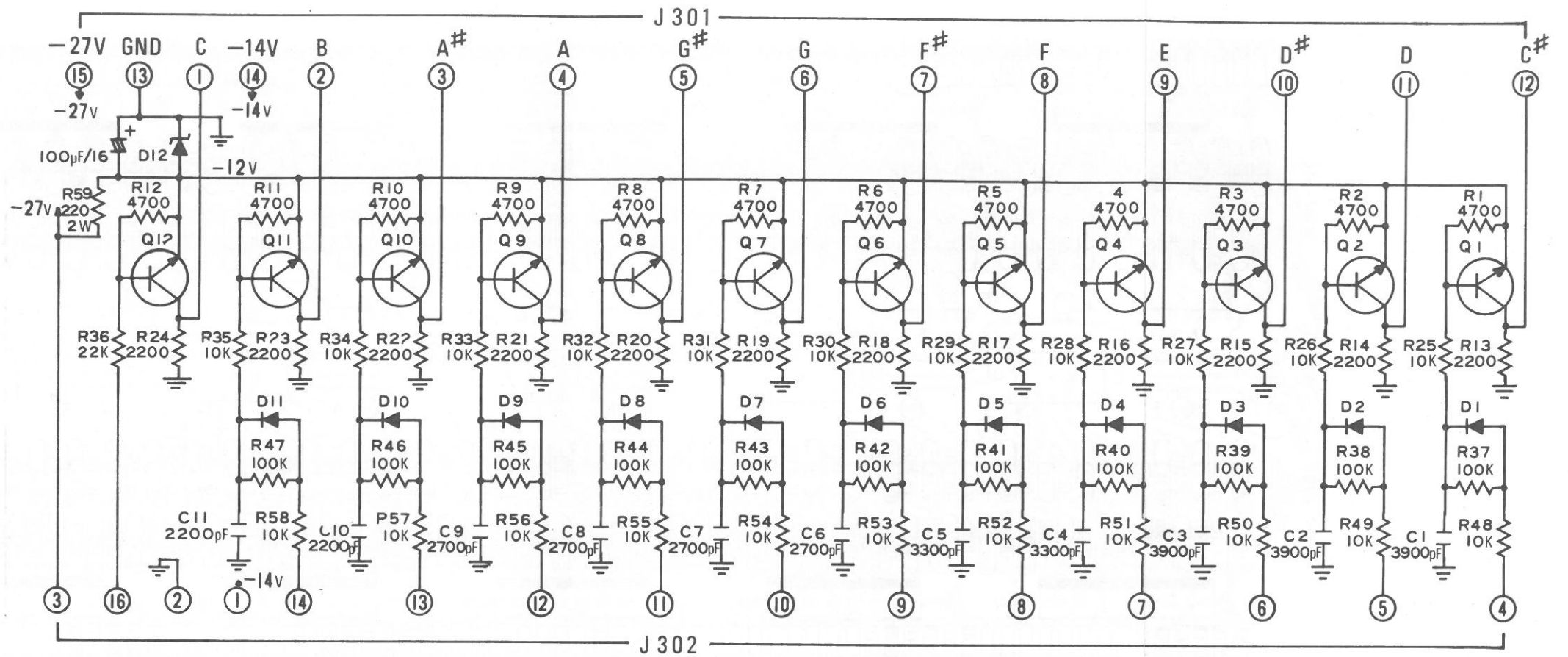

- \*NOTES**
- 1 D1 THROUGH D11 306-01017 1S2473  
D12 337-02005 02Z-12A
  - 2 UNLESS OTHERWISE SPECIFIED:  
ALL RESISTORS ARE IN OHMS. ±5%. 1/4WATT.
  - 3 Ⓛ SYMBOL DENOTES PIN NUMBERS IN PLUG.

223-35341  
223-35241

charge up without time delay, and the discharge down with time delay, and these signals are provided to buffer transistors, which operate inverter, and then these outputs wave form are provided approximately 50% duty cycle. The output of "C" Note is inverted only.

These output come on J301 pin 1 through pin 12, and these signal voltages are approximately 12 volts negative going in amplitude.

The connector J302 is connected to the connector P302 of MG-4 MDD Generator Board, and the connector J301 is connected to T1 through T12, T37, T38, and T39 of DV-4 Divider Generator Board.

FIGURE 3-3  
EF-12 (223-35341)  
M.D.D. BUFFER BOARD  
SCHEMATIC, LAYOUT & THEORY



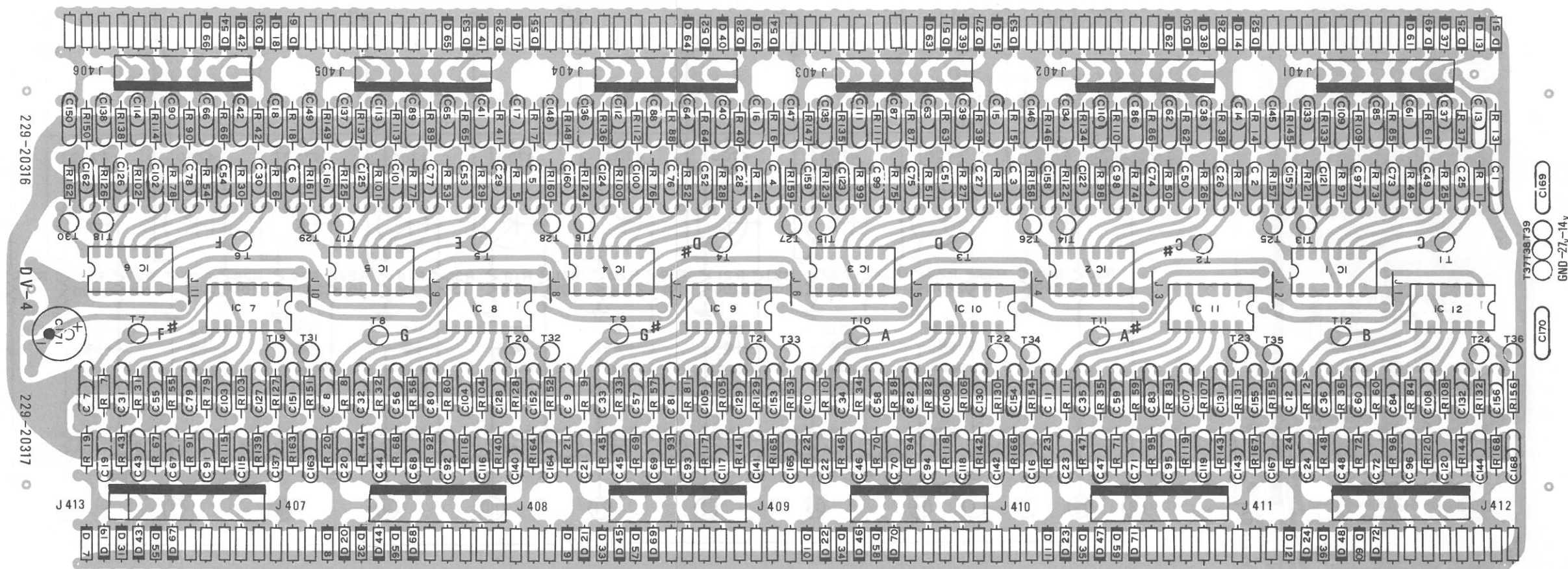

**Frequency Divider and Filter**

Assembly DV-4 contains twelve (12) IC packages and Sine Wave Filters.

These packages contain all circuitry associated with dividing the top octave frequencies actually used in the organ. The IC is a MOS type enclosed in a dual inline package, and it provides six stages of binary division to produce six octave-related outputs of the tone generator. Each output of the IC is connected to a sine wave filter. Three groups of the filters from top octave operate as follows; the square wave from divider is transformed into a triangular wave by CR low pass filter (ex: C1 and R1), and is additionally transformed into similar sine waves by a diode clipper (ex: D1 and D13). Other groups of the filters consist of only CR type with a sloping character of 12 dB per octave (ex: C73, R73, C85, and R85).

A voltage for a common line of diodes, D1 through D72, is smoothed by C171. It is about -6 volts D.C. and is added to bus bars of the keyboard. When this voltage is much different from the mean value for the signal of divider out (over 0.3 volt), a key noise will be loud.

**CAPACITORS**

- .01 C95, 96
- .015 C80 thru 84, 89 thru 94
- .022 C10 thru 12, 75 thru 79, 85 thru 88
- .027 C8, 9, 34 thru 36, 73, 74, 108, 119, 120
- .033 C5 thru 7, 31 thru 33, 104 thru 107, 113 thru 118
- .039 C1 thru 4, 29, 30, 101 thru 103, 112
- .047 C25 thru 28, 98 thru 100, 109 thru 111
- .056 C58 thru 60, 97, 130 thru 132, 141 thru 144
- .068 C55 thru 57, 127, 128, 129, 138 thru 140
- .082 C53, 54, 124 thru 126, 134 thru 137
- .1 C49 thru 52, 121 thru 123, 133, 145 thru 169

**RESISTORS**

- 560 R13 thru 24
- 1000 R37 thru 48, 61 thru 72
- 10K R1 thru 12
- 22K R25 thru 36, 49 thru 60
- 47K R73 thru 84, 86 thru 88, 94, 97 thru 133, 135, 137 thru 141, 143, 144, 151 thru 156, 162, 167, 168
- 56K R85, 89 thru 93, 95, 96, 134, 136, 142, 160, 161, 166
- 68K R158, 159, 165
- 82K R157, 163, 164
- 100K R145 thru 150

\*NOTES All capacitors are in microfarads, ±10%, 50 volts.  
All resistors are in ohms, ±5%, ¼ watt.

FIGURE 3-4  
DV-4A (229-20317)  
DIVIDER BOARD  
LAYOUT & THEORY

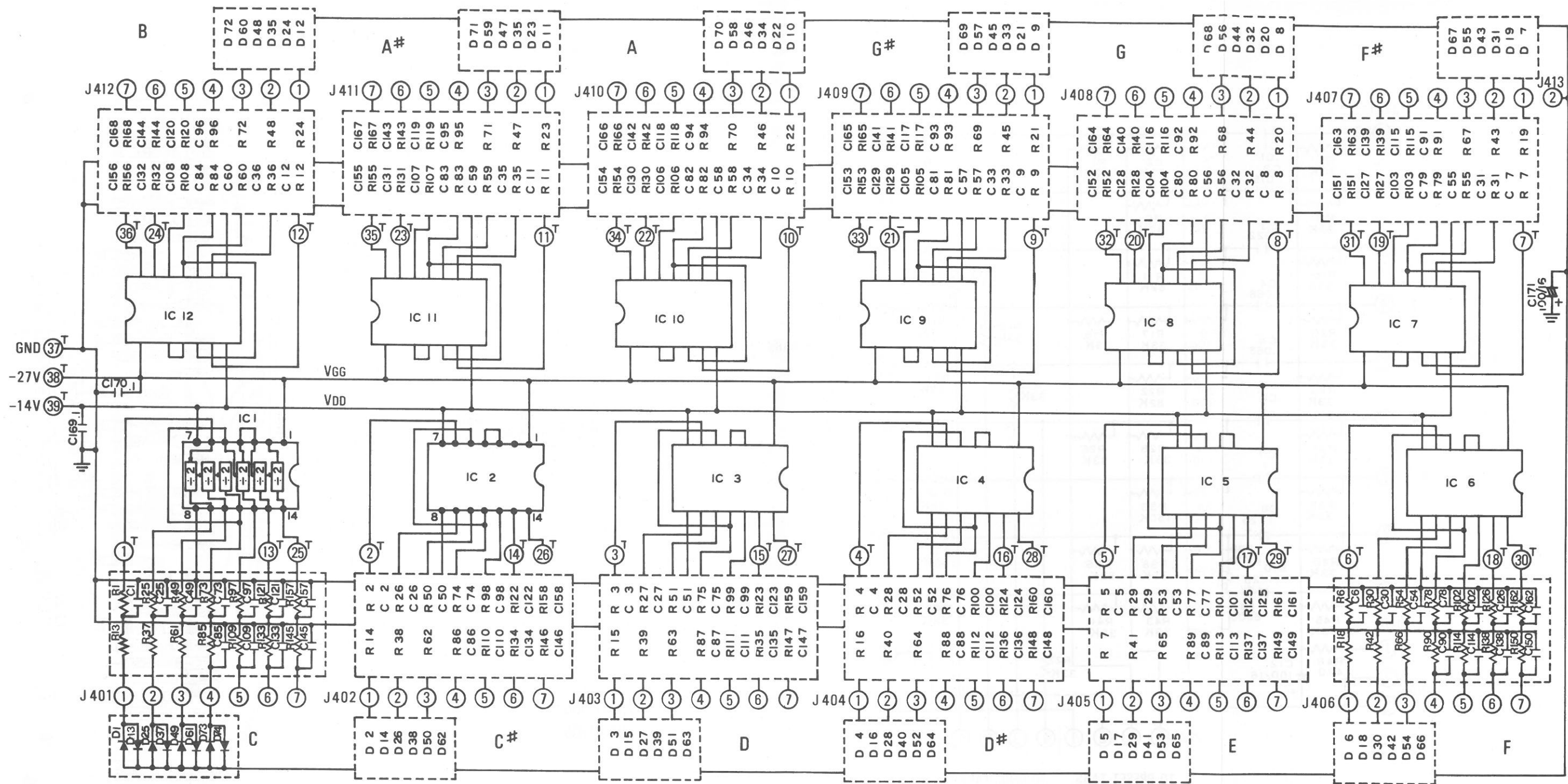

**\* NOTES**

- 1 D2 THROUGH D74 306-01017 1S2473 or 306-01005 1S1555  
IC1 THROUGH IC12, 319-01007 MM5824
- 2 UNLESS OTHERWISE SPECIFIED:  
ALL RESISTORS ARE IN OHMS,  $\pm 5\%$ , 1/4 WATT.  
ALL CAPACITORS ARE IN MICROFARADS, AND  
C1 THROUGH C170 ARE USED MYLAR TYPE,  $\pm 10\%$ .
- 3 (1) SYMBOL DENOTES NUMBERS IN TERMINAL.  
(1) SYMBOL DENOTES NUMBERS IN PLUG.

229-20317  
229-20217

FIGURE 3-5  
DV-4A (229-20317)  
DIVIDER BOARD  
SCHEMATIC

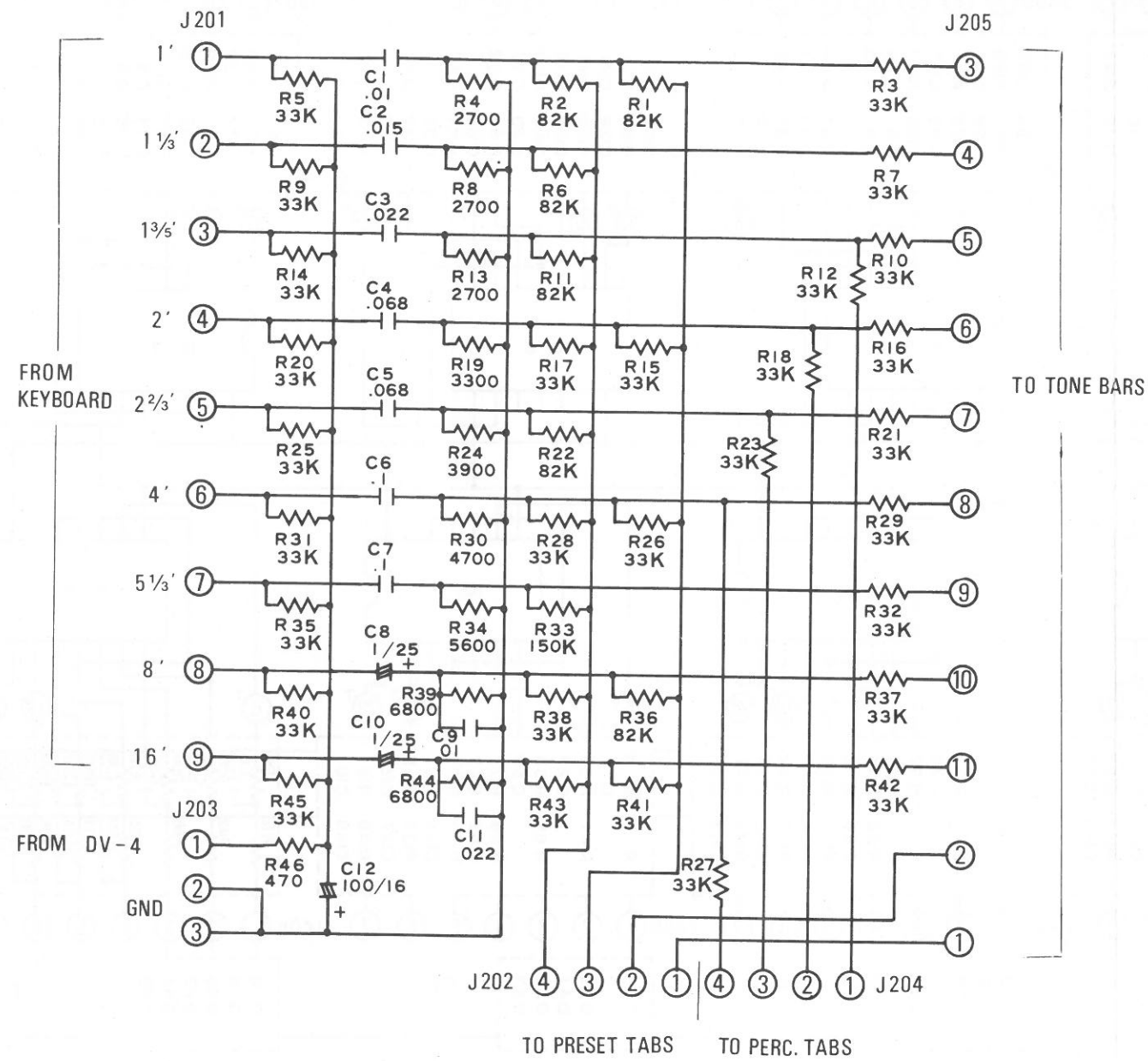

•NOTE  
 ALL RESISTORS ARE IN OHMS ±5%, 1/4WATT,  
 ALL CAPACITORS ARE IN MICROFARADS,  
 AND C8, C10 ARE USED TANTALUM.

232-11306  
 232-11206

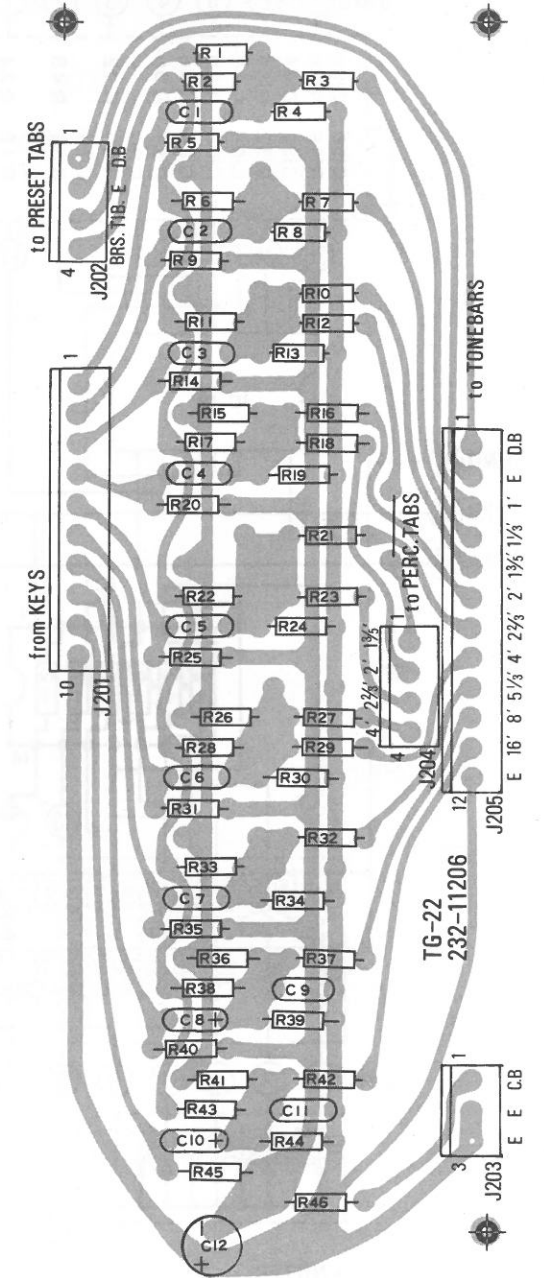

**Mix Tone Board TG-22**

This assembly feeds audio signals from bus bars to Tone Bars and Percussion tabs, or makes the preset tones. A click bias from DV-4(A) appears at J203-1, and is filtered by R46 and C12, then it is fed to each bus bars through R5, 9, 14, 20, 25, 31, 35, 40, 45.

FIGURE 3-6  
 TG-22 (232-11206)  
 MIX TONE BOARD  
 SCHEMATIC, LAYOUT  
 AND THEORY



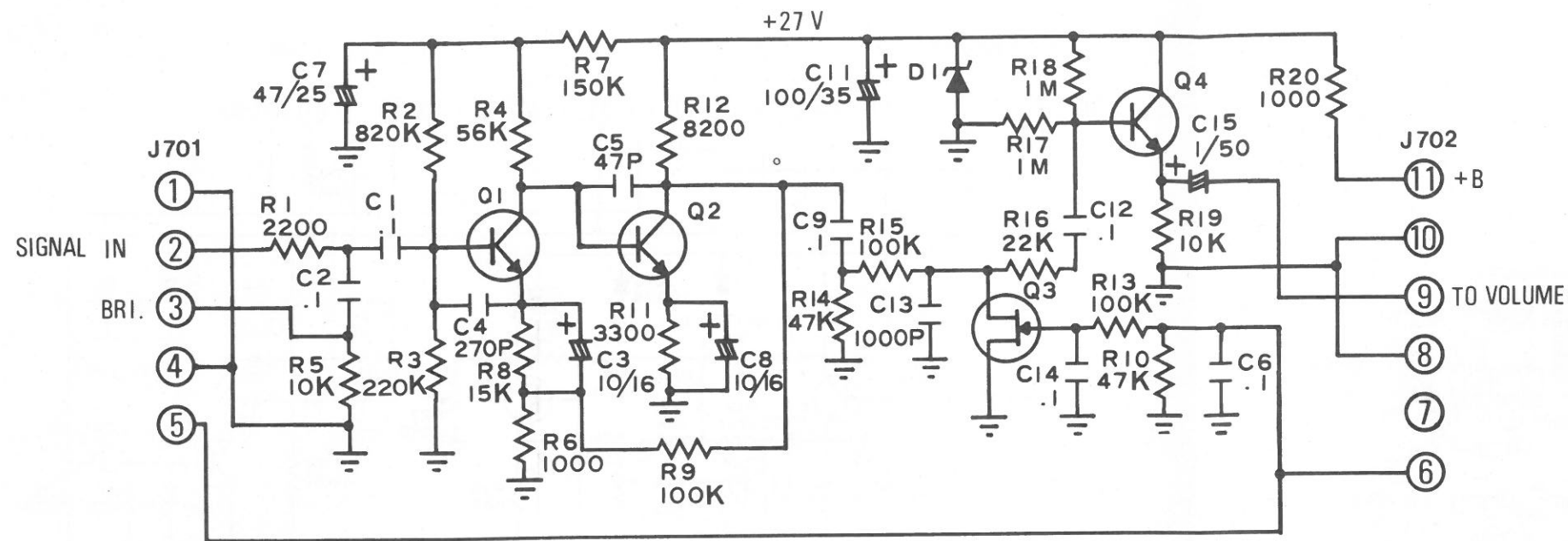

- NOTES
- |           |           |           |
|-----------|-----------|-----------|
| 1 D1, 2 4 | 337-06015 | RD-27EB   |
| Q1        | 305-03023 | 2SC1000GR |
| Q3        | 305-05005 | 2SK30A-D  |
- 2 UNLESS OTHERWISE SPECIFIED:  
 ALL RESISTORS ARE IN OHMS. ±5%. 1/4WATT.  
 ALL CAPACITORS ARE IN MICROFARADS.  
 AND C15 IS USED TANTALUM.

219-51311  
 219-51211

#### Pre Amp Board

This Pre Amp Board assembly has a gate consisting of R15 and Q3 which turns off the signal from the keyboard in keying off condition. An input signal from the preset tabs appears at J701-2 and is amplified about 40 dB by Q1 and Q2. The amplified signal is conducted to the drain (D) of Q3 through C9 and R15. When a manual key is not depressed, a voltage of J702-6 is ground potential, and then Q3 turns on because the Gate of Q3 is at zero bias, therefore the signal is shunted to ground through Q3. When a key is depressed, J702-6 becomes about 10 volts D.C., Q3 is turned off, and the signal appears at J702-9 through an emitter follower Q4.

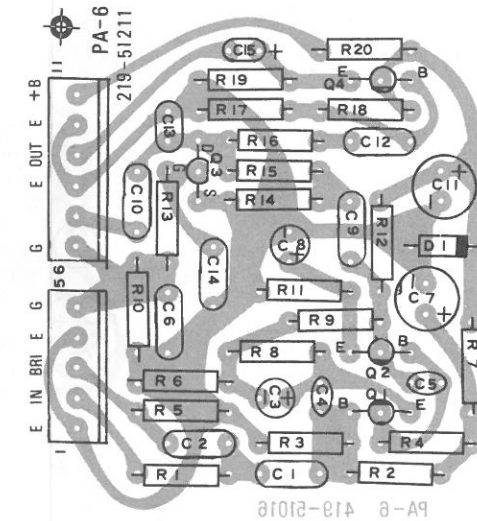
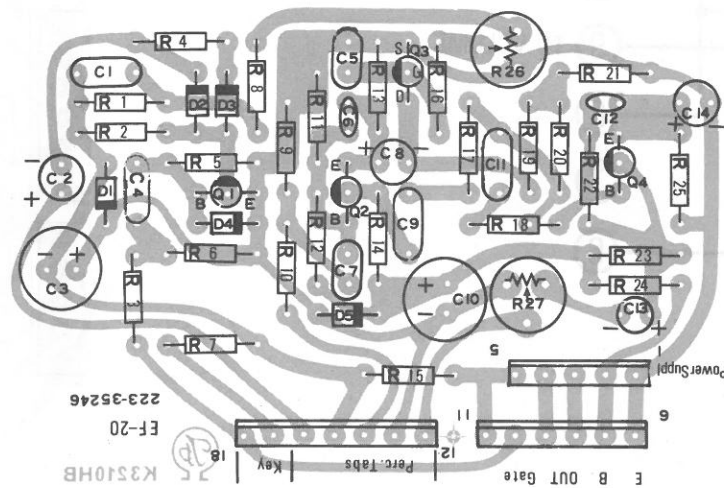

FIGURE 3-7  
 PA-6 (219-51211)  
 PRE AMP BOARD  
 SCHEMATIC, LAYOUT  
 AND THEORY



### Percussion Board EF-20

This assembly consists of amplifiers and modulation circuitry. The former is comprised of Q2, Q4, and the surrounding capacitors and resistor, the latter is comprised of Q1, Q3, D2, D3, D4, C1, C2, C4, C5, R1, R2, R4, R26, etc. The -27 volts supplied from power supply is stepped down to -12 volts by R15 and D1. It is sent through R7 from J604-17, to a manual key switch, and returns to J604-18.

When a key is depressed, the voltage of J604-18 varies from zero to -10 volts, for a instant, a negative pulse is generated at the Base of Q1 by C4 and R5, so Q1 turns on D2 and D3 also turn on; consequently as each cathode of D2 and D3 vary from -12 volts to zero potential, C2 (only "Slow Decay") and C1 are charged to 12 volts, then these begin discharging gradually through R1 and R4 until zero potential. Thus a Percussion pulse is made at cathode of D3, and is fed through R8, potentiometer R26, R16, to the gate of Q3.

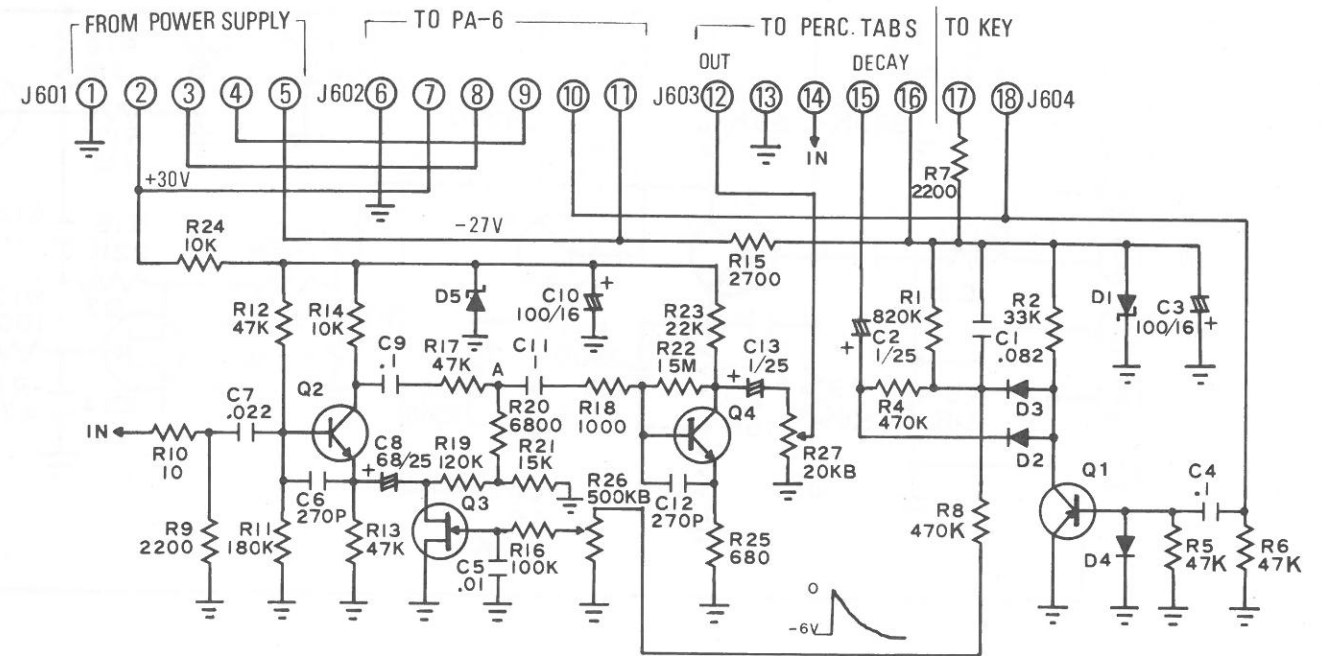

### NOTES

- |               |              |           |
|---------------|--------------|-----------|
| 1 D1          | 337-02005    | 02Z12A    |
| D2 THROUGH D4 | 306-01017    | 1S2473    |
|               | or 306-01005 | 1S1555    |
| D5            | 337-02004    | 02Z8.2A   |
| Q1            | 305-01008    | 2SA7330   |
| Q2,4          | 305-03023    | 2SC1000GR |
| Q3            | 305-05005    | 2SK30A-D  |

### 2 UNLESS OTHERWISE SPECIFIED:

ALL RESISTORS ARE IN OHMS.  $\pm 5\%$  1/4WATT,  
ALL CAPACITORS ARE IN MICROFARADS,  
AND C2, C8, C13, ARE USED TANTALUM.

223-35346  
223-35246

An audio signal from Percussion tabs appears at J603-14, and is fed thru C7 to the base of Q2. Because of unequal emitter and collector loads (R13 and R14), the signal across R13 is in phase with the signal at the base of Q2 and the signal across R14 is 180° shifted in phase. The signals from the collector and emitter of Q2 are mixed thru R17 plus R20, and thru R19 plus R21 in such a way that both appear at point (A) in equal level and out of phase. The result is that both signals cancel each other and there is no output from the gate. This is the condition when the gate is closed.

When the DC voltage from the F.E.T. gate Q3 is removed, that is to say, the moment that the Percussion pulse is fed to the gate, the drain to source resistance becomes very small (a few hundred ohms) and this virtually places C8 in parallel with R13. The result is that the signal at the collector of Q2 increases, because C8 decouples the signal current degeneration in R13. This, in turn unbalances the signal null point at point A and gate has maximum output, or is "open".

A variable DC voltage impressed upon gate Q3 will cause a variable signal output from the gate.

FIGURE 3-8  
EF-20 (223-35246)  
PERCUSSION BOARD  
SCHEMATIC, LAYOUT  
AND THEORY

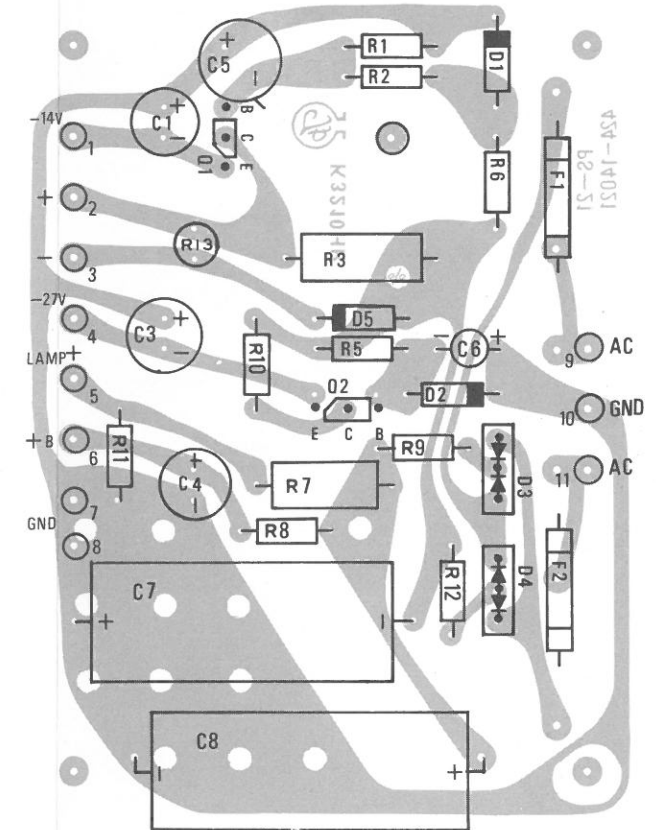
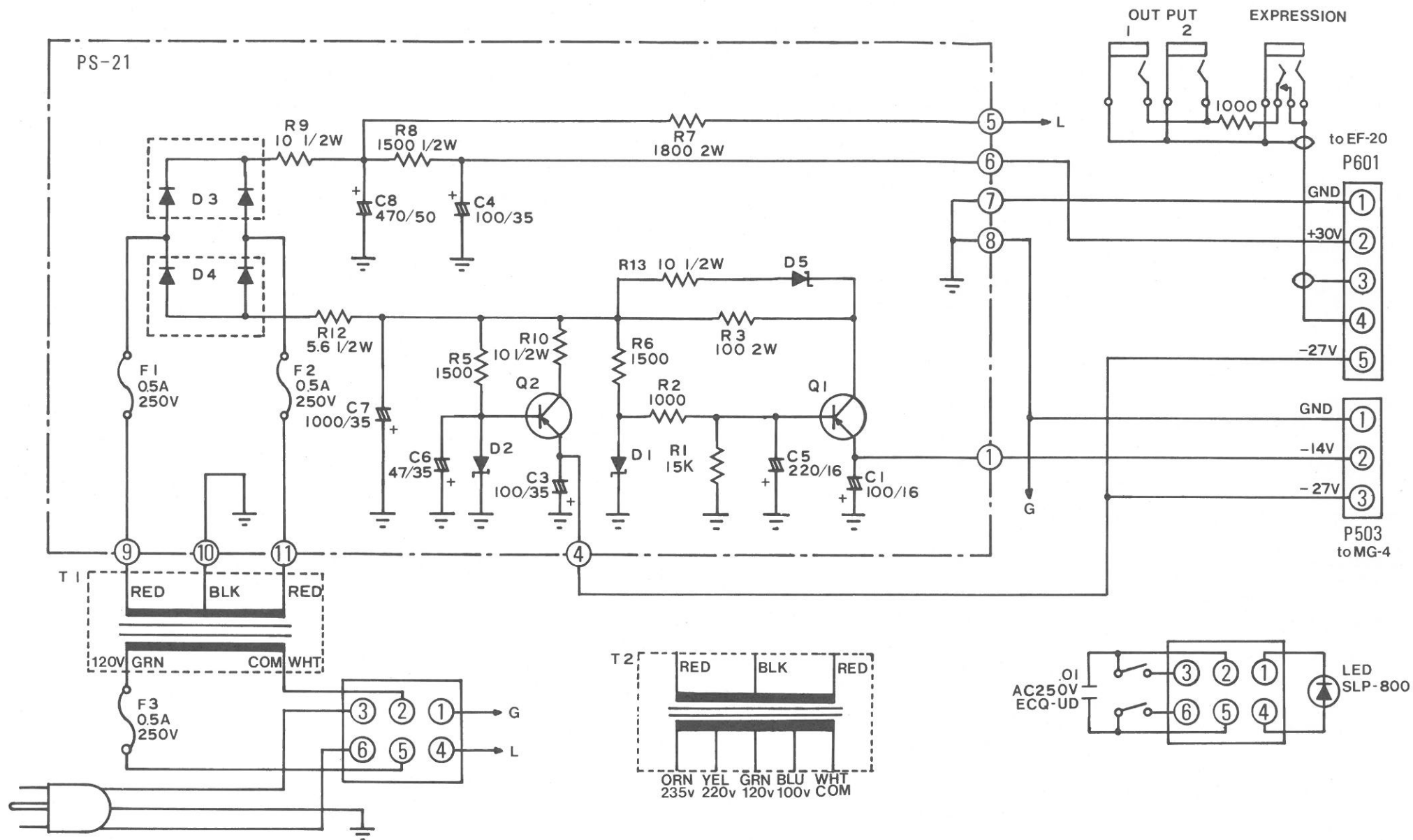

• NOTES

- |          |            |          |                                |
|----------|------------|----------|--------------------------------|
| 1, D1, 5 | 337-06013  | RD-15EC  | 2. UNLESS OTHERWISE SPECIFIED: |
| D2       | 337-06015  | RD-27EB  | ALL RESISTORS ARE IN OHMS,     |
| D3       | 306-01023  | 1B2C1    | ±5%, 1/4 WATTS.                |
| D4       | 306-01024  | 1B2Z1    | ALL CAPACITORS ARE IN MICRO    |
| Q1, 2    | 305-01004  | 2SA699AQ | -FARADS.                       |
| F1, 2, 3 | 301-01010  | MGP UL   | 3. BOXED IN AREA IS PS-21      |
| T1       | 307-01078B | E-06B UL | POWER SUPPLY BOARD             |
| T2       | 307-01077B | E-06B    | 4. T1 IS FOR UL, CSA.          |
|          |            |          | T2 IS FOR THE OTHERS.          |

224-14311  
224-14211

FIGURE 3-9  
POWER SUPPLY UNIT (105-08205)  
PS-21 BOARD (224-14211)  
SCHEMATIC & LAYOUT



## SECTION IV. PARTS LIST

<b>CONSOLE FRONT VIEW</b> .....	<b>4-2</b>	<b>POWER SUPPLY UNIT</b> .....	<b>4-4</b>
MUSIC PANEL ASSEMBLY		PRINTED WIRING BOARD	
CABINET ASSEMBLY		PS-21	
LEFT TABS ASSEMBLY		POWER TRANSFORMER	
RIGHT TABS ASSEMBLY		AC CORD	
TONE BARS ASSEMBLY		JACK	
EXPRESSION ASSEMBLY		FUSE	
CONTROL PANEL		<b>EXPRESSION PEDAL</b> .....	<b>4-4</b>
FRONT STRIP		PEDAL MAT	
PIPE LEGS		POTENTIOMETER	
END BLOCK		CORD ASSEMBLY	
SPACE BOARD		GUM LEG	
KNOB SCREW		<b>MANUAL ASSEMBLY</b> .....	<b>4-5</b>
MANUAL ASSEMBLY		NATURAL KEY ASSEMBLY	
<b>CONSOLE BOTTOM VIEW</b> .....	<b>4-3</b>	SHARP KEY ASSEMBLY	
KEY COVER		L PLATE	
VINYL COVER		BUS BAR	
BOTTOM COVER		RESISTOR	
HAMMOND BADGE		SWITCH COVER	
HANDLE		<b>PRINTED CIRCUIT BOARD PARTS</b> .....	<b>4-6</b>
CATCH CLIP		MDD GENERATOR MG-4(C) .....	4-6
<b>FRONT VIEW – PANEL UP</b> .....	<b>4-3</b>	MDD BUFFER EF-12 .....	4-6
PRINTED CIRCUIT BOARD ASSEMBLIES		DIVIDER GENERATOR DV-4 .....	4-6
MG-4C (MDD GENERATOR)		MIX TONE TG-22 .....	4-6
EF-12 (MDD BUFFER)		PREAMP BOARD PA-6 .....	4-6
DV-4 (DIVIDER GENERATOR)		PERCUSSION BOARD EF-20 .....	4-7
PA-6 (PREAMP)		POWER SUPPLY BOARD PS-21 .....	4-7
TG-22 (MIXTONE)			
EF-20 (PERCUSSION)			
POWER SUPPLY UNIT			
POWER SWITCH			
POTENTIOMETER			
KEY FELT			
PILOT LAMP			
CONNECTORS			

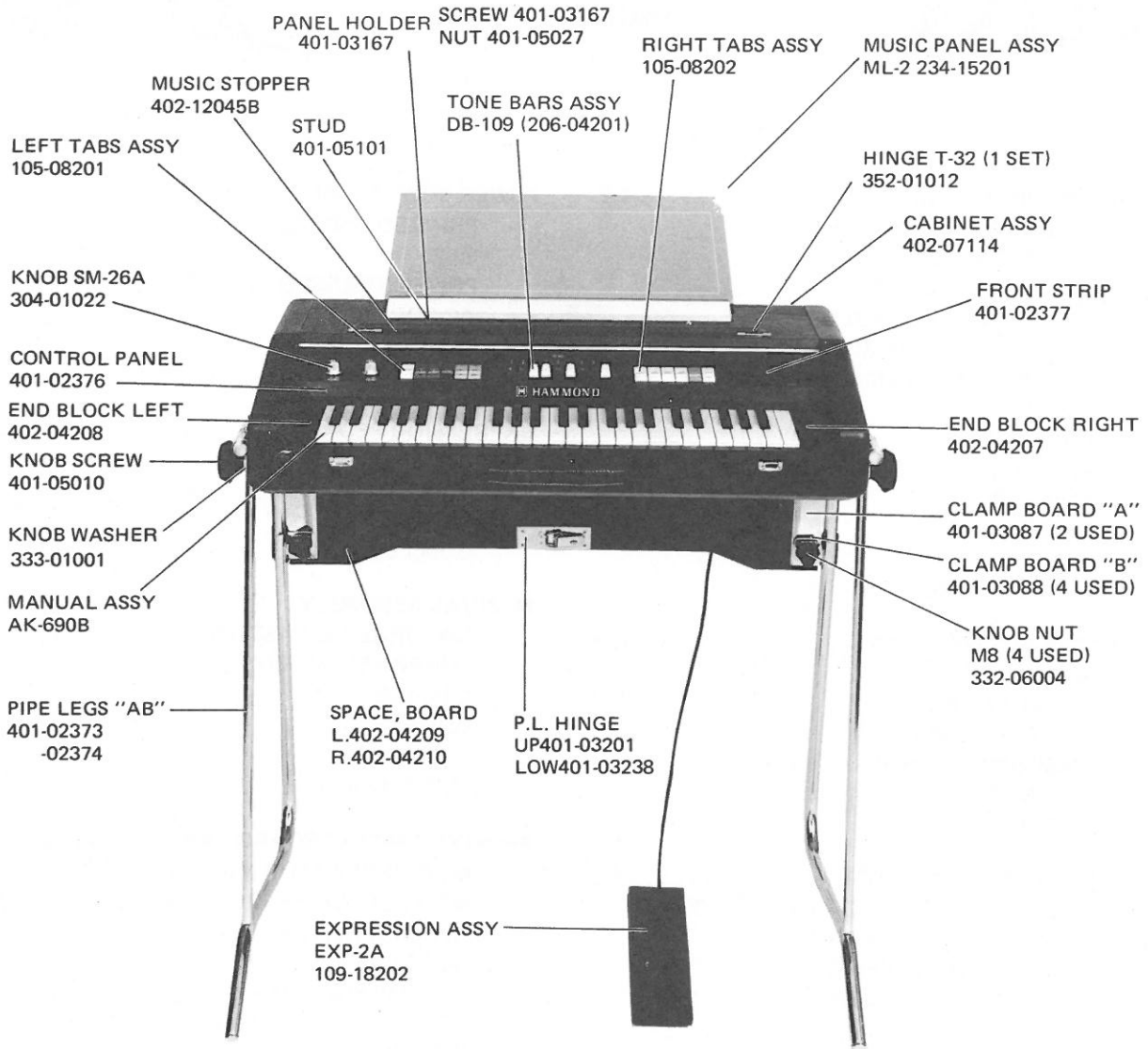

CONOSLE FRONT VIEW

LEFT TABS ASSEMBLY	105-08201	RIGHT TABS ASSEMBLY	105-08202
ROCKER TAB		ROCKER TAB	
BRILLIANCE	247-10018	SECOND HARMONIC	247-10036
VIBRATO I	247-05003	THIRD HARMONIC	247-10037
VIBRATO II	247-05004	FOURTH HARMONIC	247-10039
DELAY VIBRATO	247-08005	FIFTH HARMONIC	247-10040
OFF/PRESET/ON	247-04007	SLOW/DECAY/FAST	247-06019
TIBIA/PRESET/BRASS	247-04008	SOFT/PERC./LOUD	247-10038

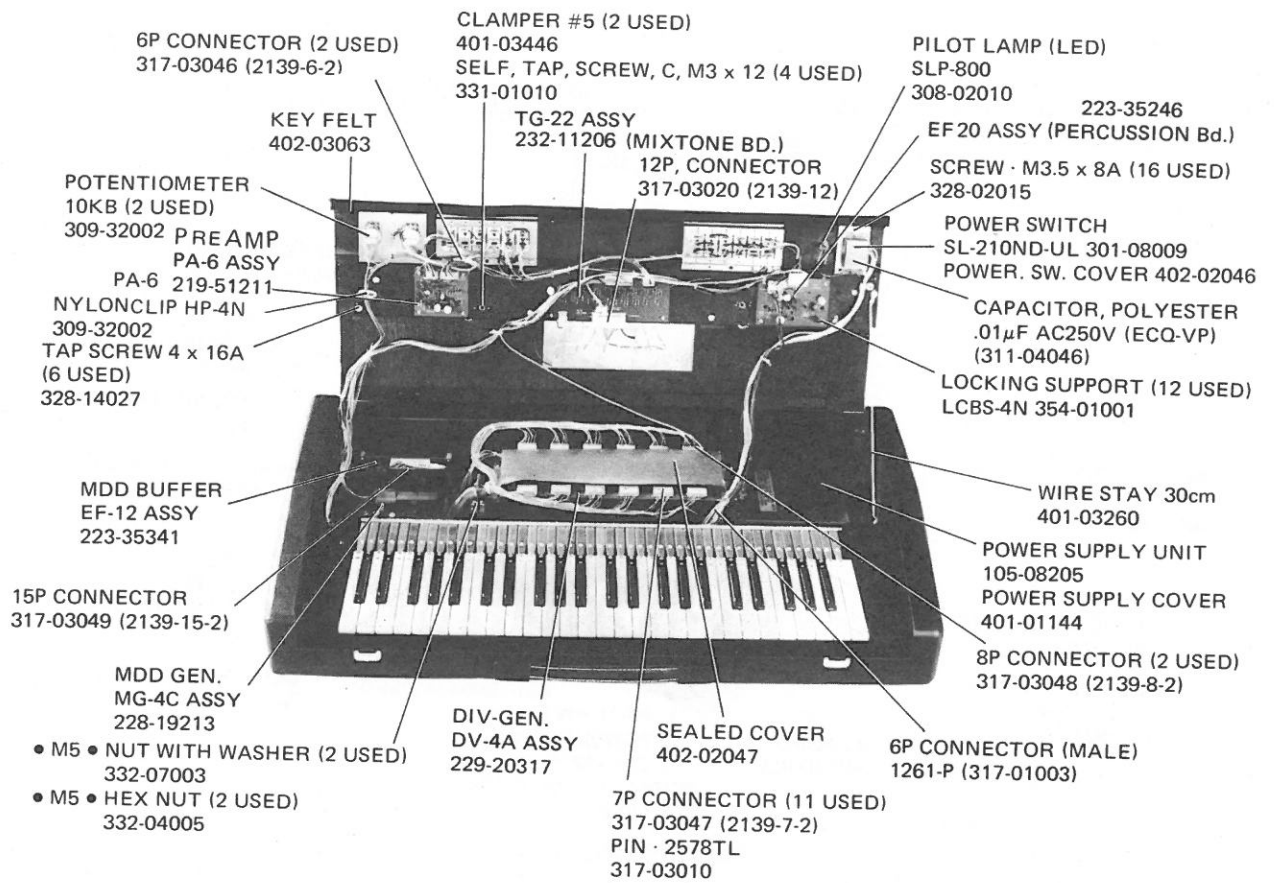

FRONT VIEW – PANEL UP

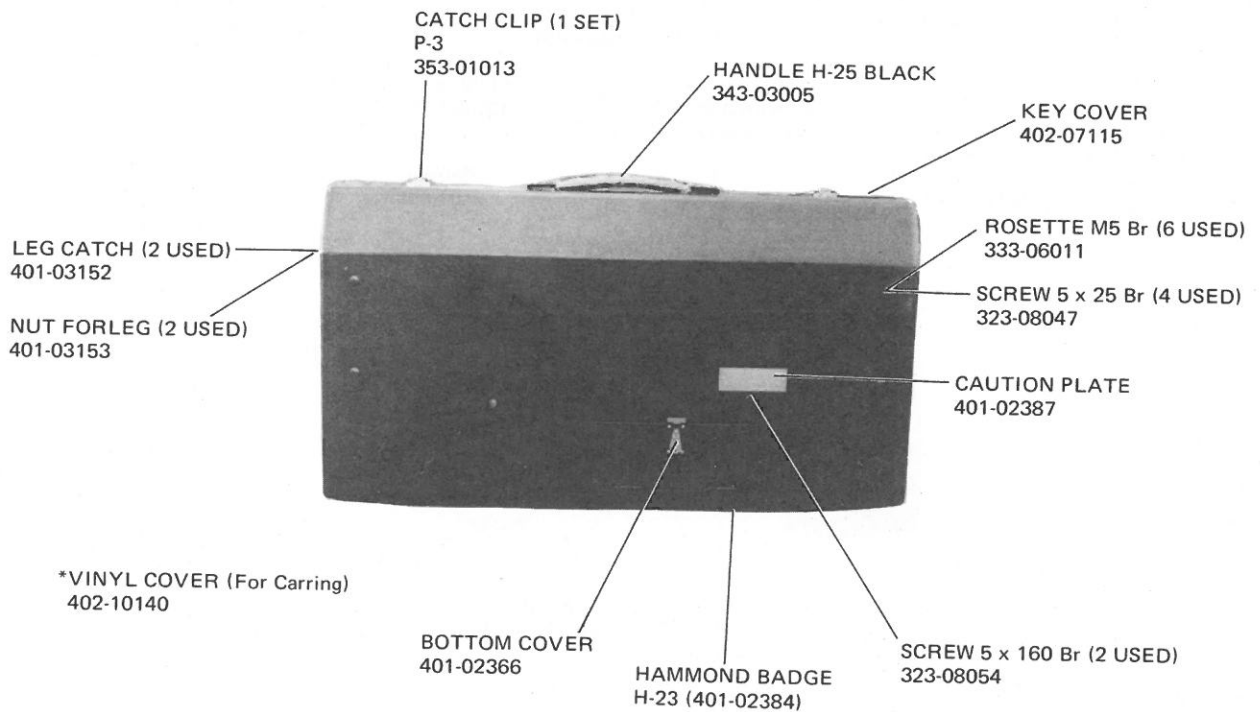

CONSOLE BOTTOM VIEW

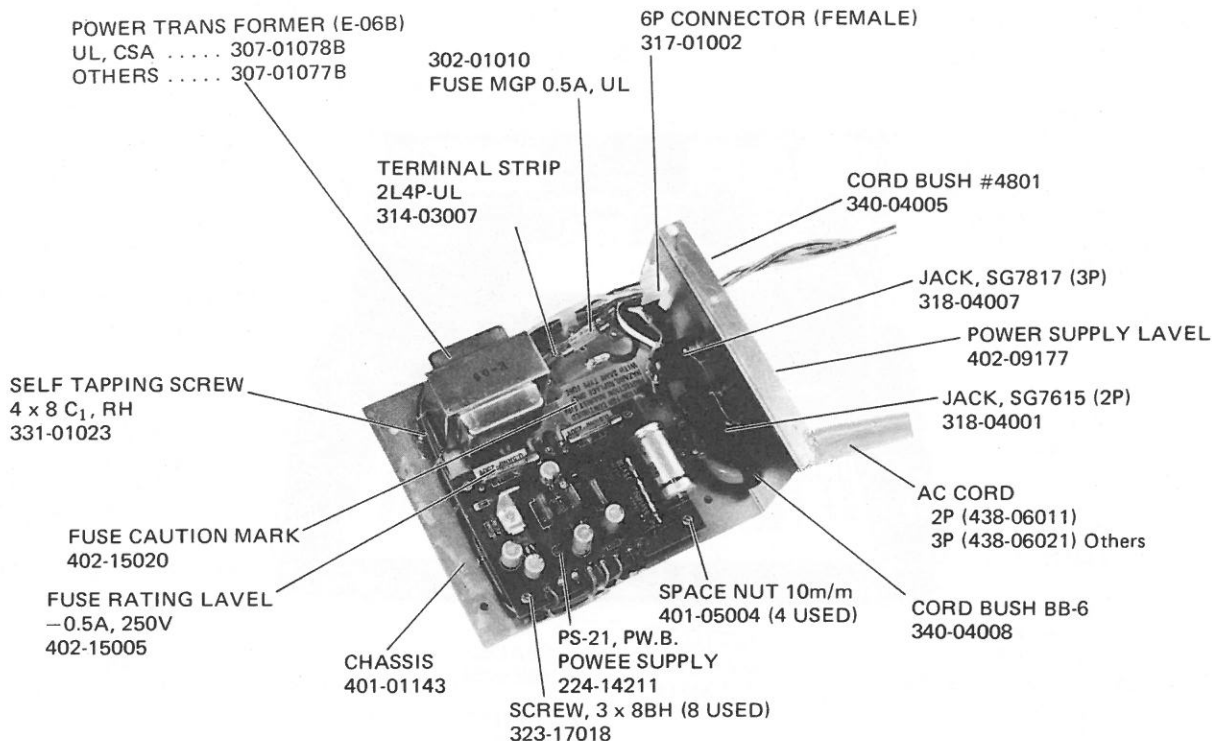

**POWER SUPPLY UNIT**

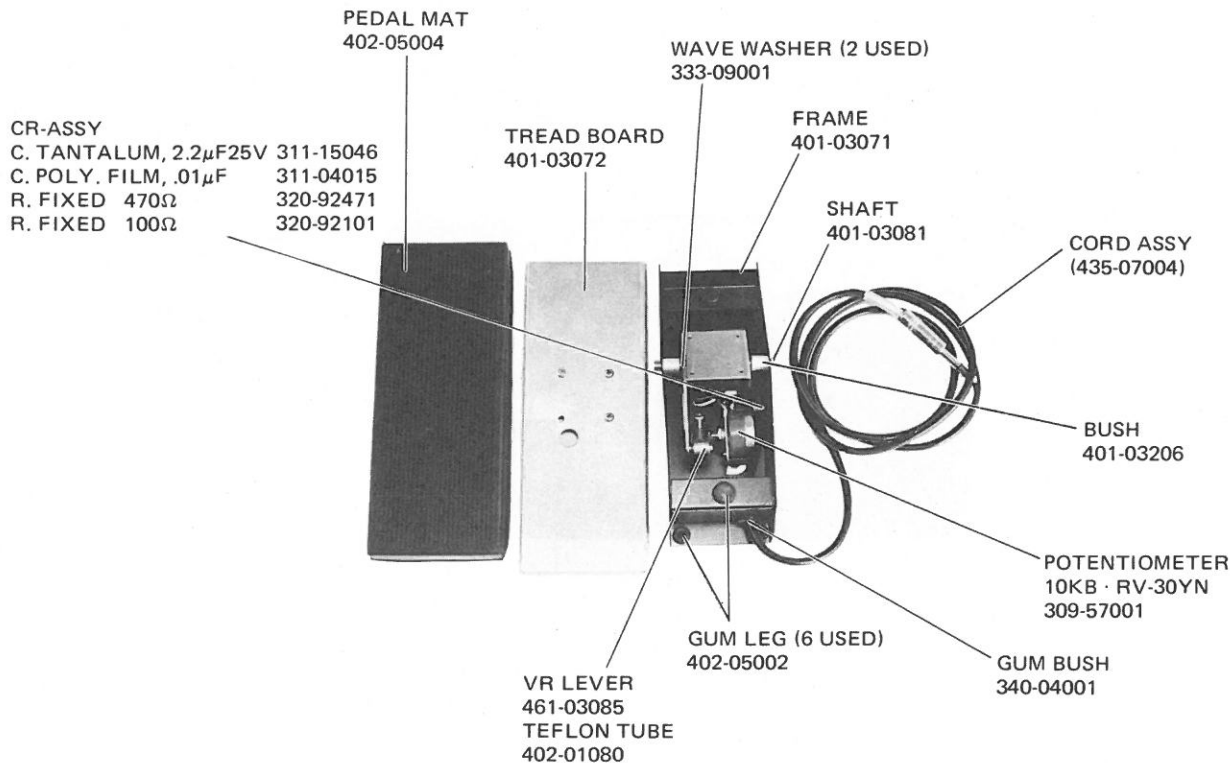

**EXPRESSION PEDAL(EXP-2A)**

NATURAL KEY ASSEMBLY

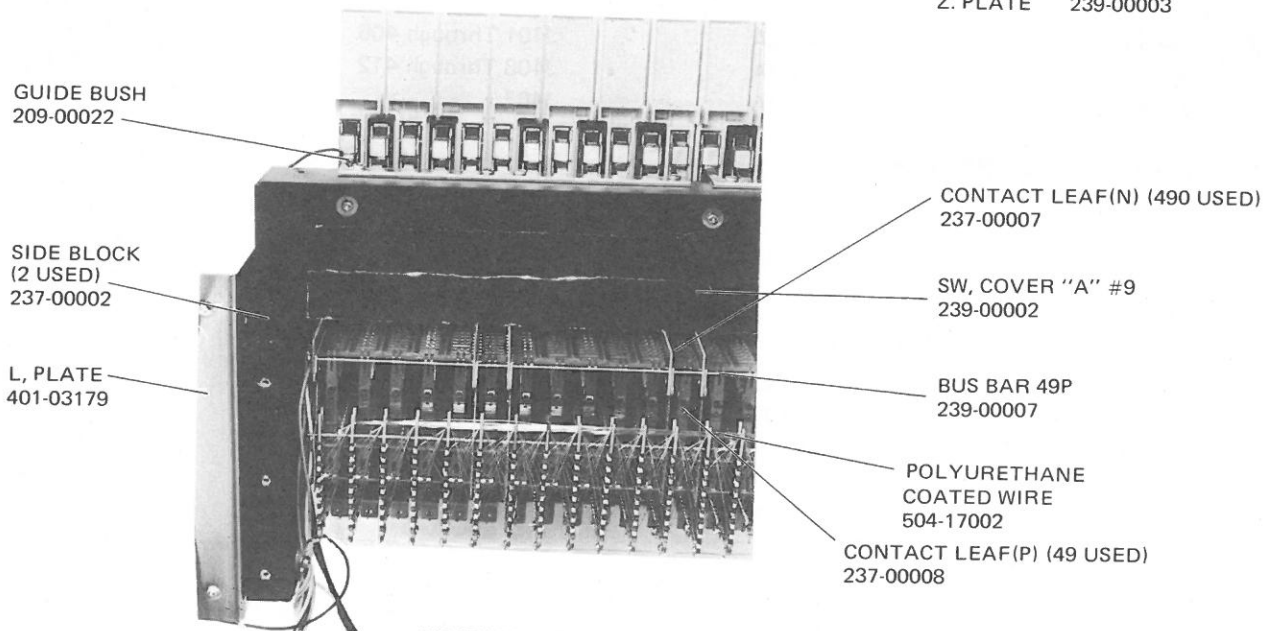
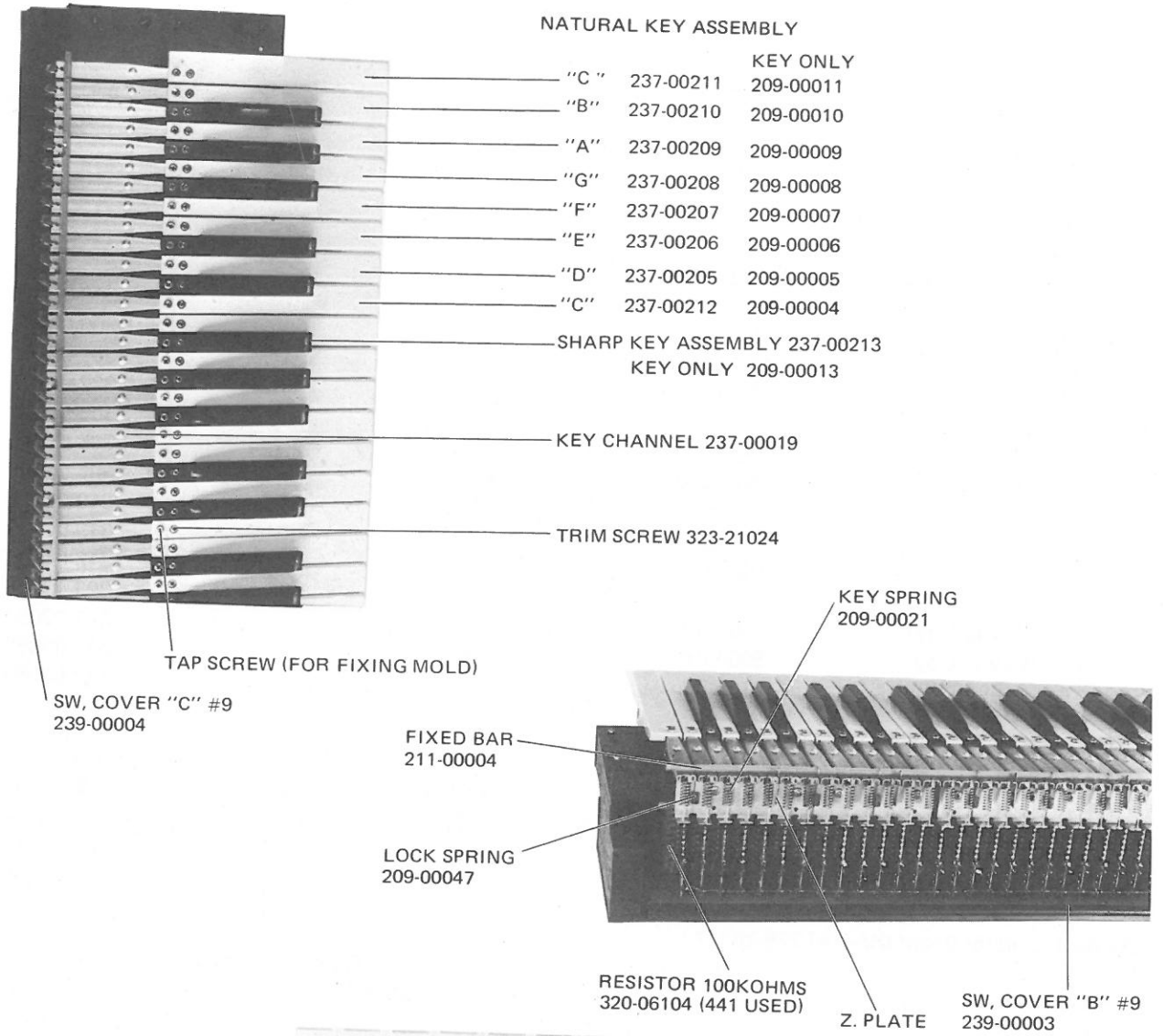

MANUAL ASSEMBLY (AK-690B)

**MDD GENERATOR BOARD MG-4(C) 228-19213**

Diode	1S2473	D2, 3, 5	306-01017
Diode, Varicap	1S2206	D1	306-05001
Diode, Zener	RD5. 6EB	D4	337-06014
Coil	10 $\mu$ H	L1	322-01028
Transistor, NPN	2SC373	Q1	305-03014
Transistor, NPN	2SC945Q	Q2, 3, 4, 5, 6, 7	305-03040
Transistor, PNP	2SA733Q	Q8	305-01008
Integrated Circuit	DM7493	IC1	319-03001
Integrated Circuit	MM5832	IC2	319-01005
Integrated Circuit	MM5833	IC3	319-01006
IC Socket 14P			303-13005
Wafer Assembly (3 Way)	5004-3A	J503	317-03053
Wafer Assembly (8 Way)	5004-8A	J502	317-03058
Socket Assembly (8 Way)	2145-8A	J501	317-03068

**MDD Buffer Board -EF-12- 223-35341**

Diode, Zener 12V	D22-12A	D-12	337-02005
Diode	1S2473	D-1 Through 11	306-01017
Wafer Assembly	5004-7A	J-301	317-03057
Wafer Assembly	5004-8A	J-301	317-03058
Wafer Assembly	2461-8C	J-302	317-03015

**Divider Generator Board DV-4(A) 229-20317**

Diode		D-1 Through 72	306-01017
Integrated Circuit	MM5824	IC-1 Through 12	319-01007
IC Socket 14P			303-13005
Wafer Assembly	2373-7A	J401 Through 406	317-03077
Wafer Assembly	5004-7A	J408 Through 412	317-03057
Wafer Assembly	5004-8A	J407	317-03058

**Mix Tone Board TG-22 232-11206**

Wafer Assembly	5004-10A	J201	317-03060
Wafer Assembly	5004- 4A	J202, 204	317-03054
Wafer Assembly	2373-12A	J205	317-03101
Wafer Assembly	2373- 3A	J203	317-03073

**Preamplifier Board PA-6 219-51211**

Diode, Zener 27v	RD27EB	D1	337-06015
Transistor, NPN	2SC1000GR	Q1, 2, 4	305-03023
Transistor, F.E.T.	2SK30AD	Q3	305-05005
Wafer Assembly	5004-5A	J701	317-03055
Wafer Assembly	5004-6A	J702	317-03056

**Percussion Board EF-20 223-35246**

Trim. Pot	20K ohms	R27	336-01007
Trim. Pot.	500K ohms	R26	336-01010
Diode	1S2473	D4, 3, 2	306-01017
Diode, Zener 12v	02Z12A	D1	337-02005
Diode, Zener 8.2v	02Z8. 2A	D5	337-02004
Transistor, PNP	2SA733Q	Q1	305-01008
Transistor, NPN	2SC1000GR	Q2, 4	305-03023
Transistor, F.E.T.	2SK30AD	Q3	305-05005
Wafer Assembly	5004-5A	J601	317-03055
Wafer Assembly	5004-6A	J602	317-03056
Wafer Assembly	2373-7A	J603	317-03077

**Power Supply Board PS-21 224-14211**

Diode	1B2C1	D3	306-01023
Diode	1B2Z1	D4	306-01024
Diode, Zener 27v	RD27EB	D2	337-06015
Diode, Zener 15v	RD15EC	D1, 5	337-06013
Transistor	2SA699AQ	Q1, 2	305-01004
Heat Sink	KL-30-10		341-06003
Fuse, Pig Tail	MGP 0.5A UL	F1, 2	301-01010