

LE Logan electronics s. r. l.

Schematic Diagram

Piano Strings Synthesizer

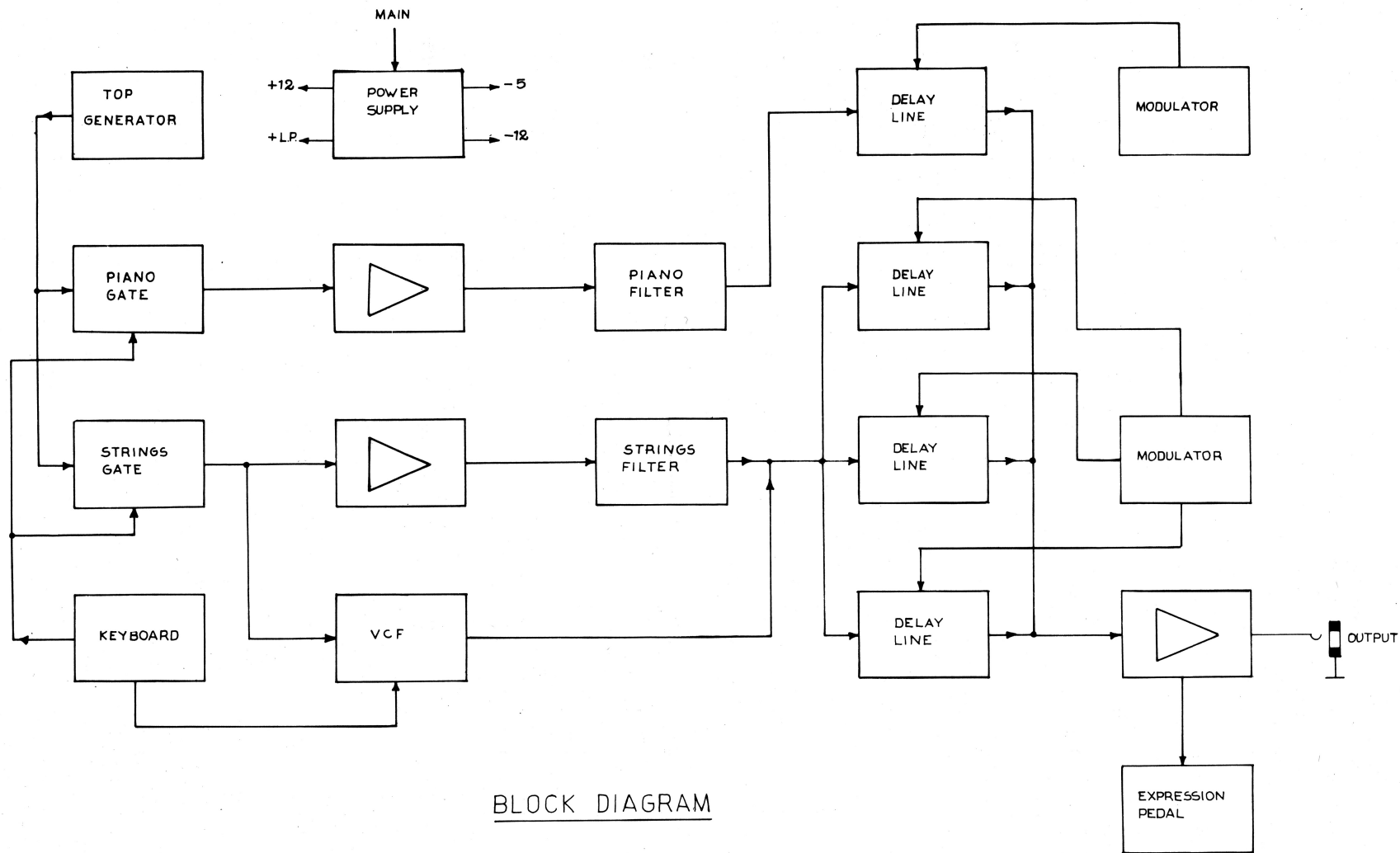

BLOCK DIAGRAM

<https://www.servicemanual.altervista.org>

	DWG1	CODE	DATE	REVISION
		PIANO STRINGS SYNTH	<i>[Signature]</i>	OF

KEYBOARD

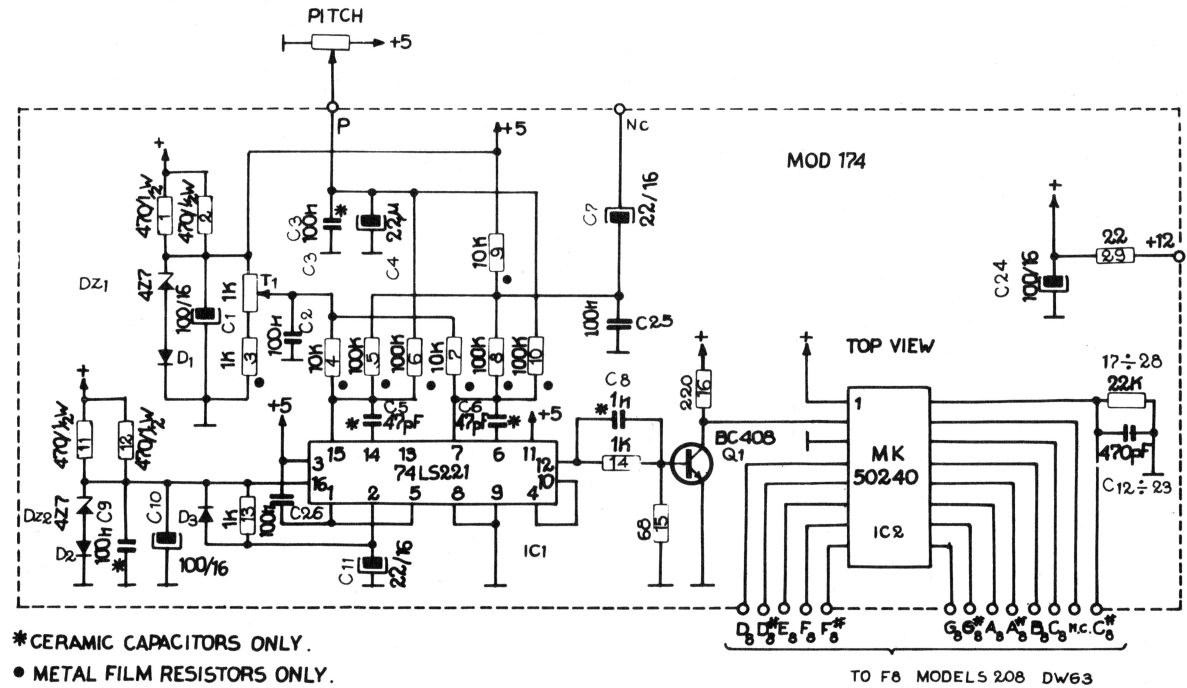
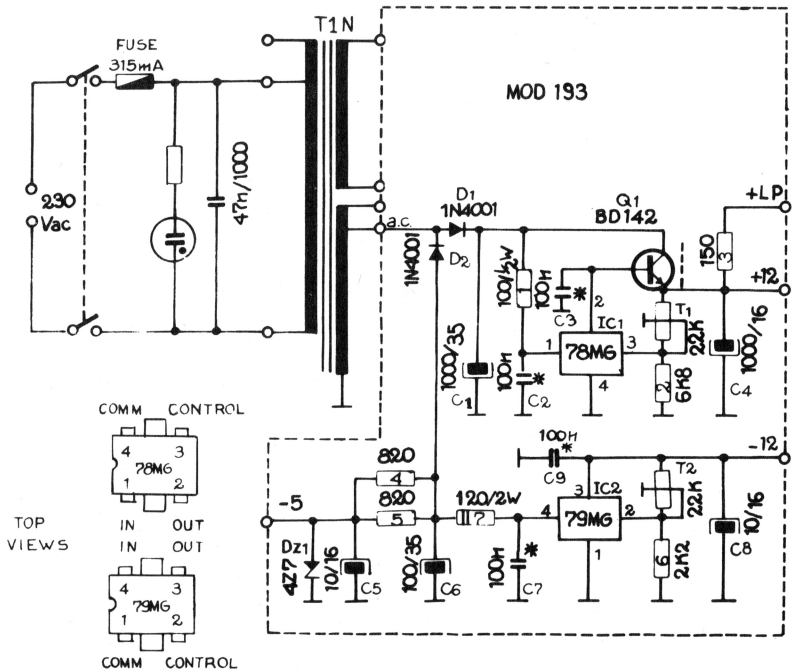
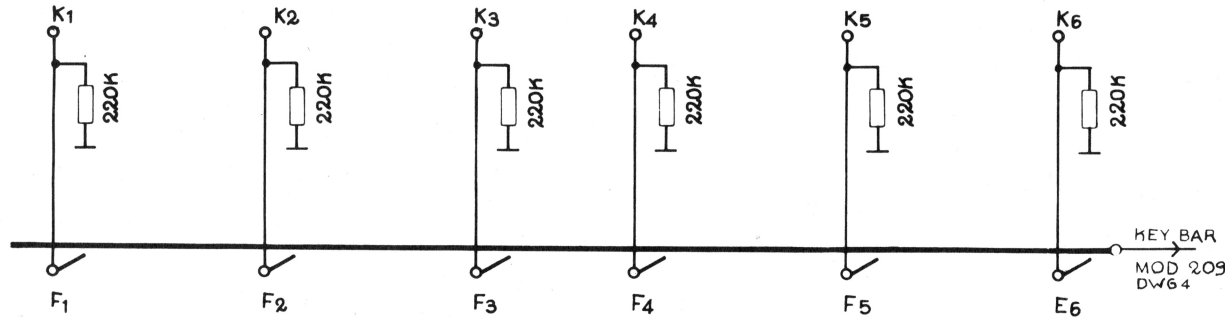

* CERAMIC CAPACITORS ONLY.
 • METAL FILM RESISTORS ONLY.

 LOGAN Electronics	DW62	CODE	DATE	REVISION
		PIANO STRINGS SYNTH		OF

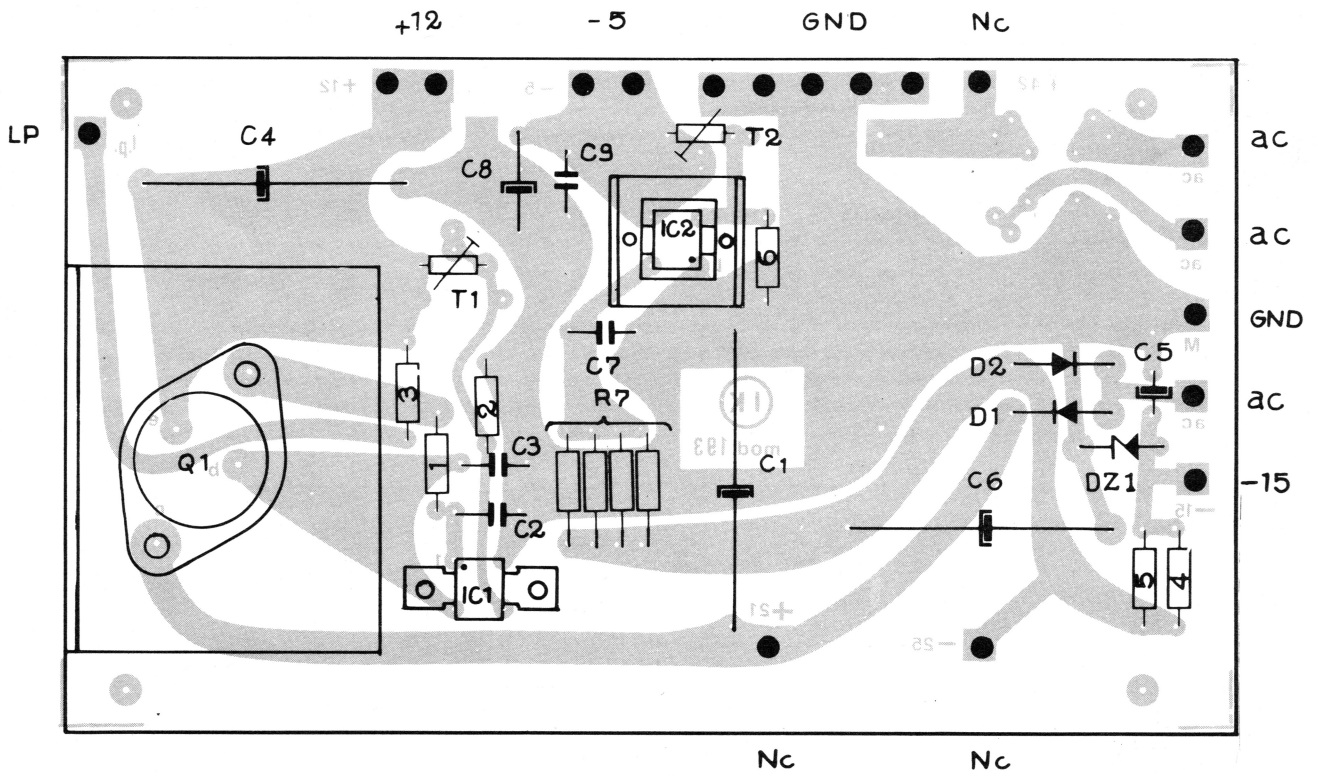

MOD 193

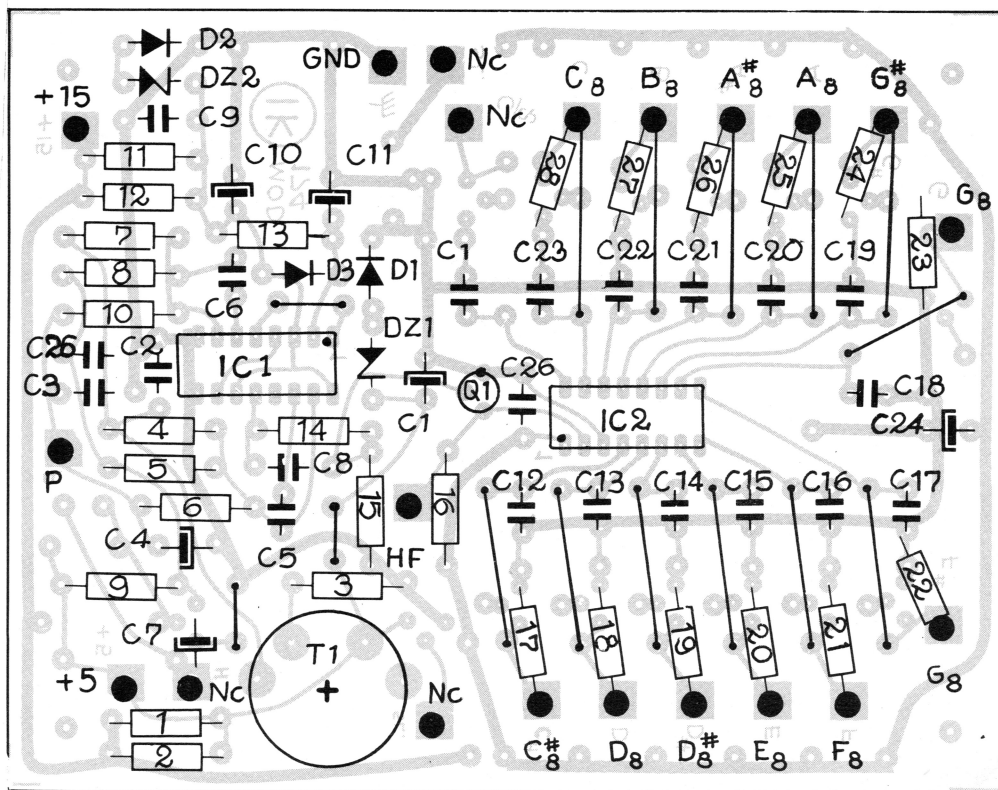

MOD 174

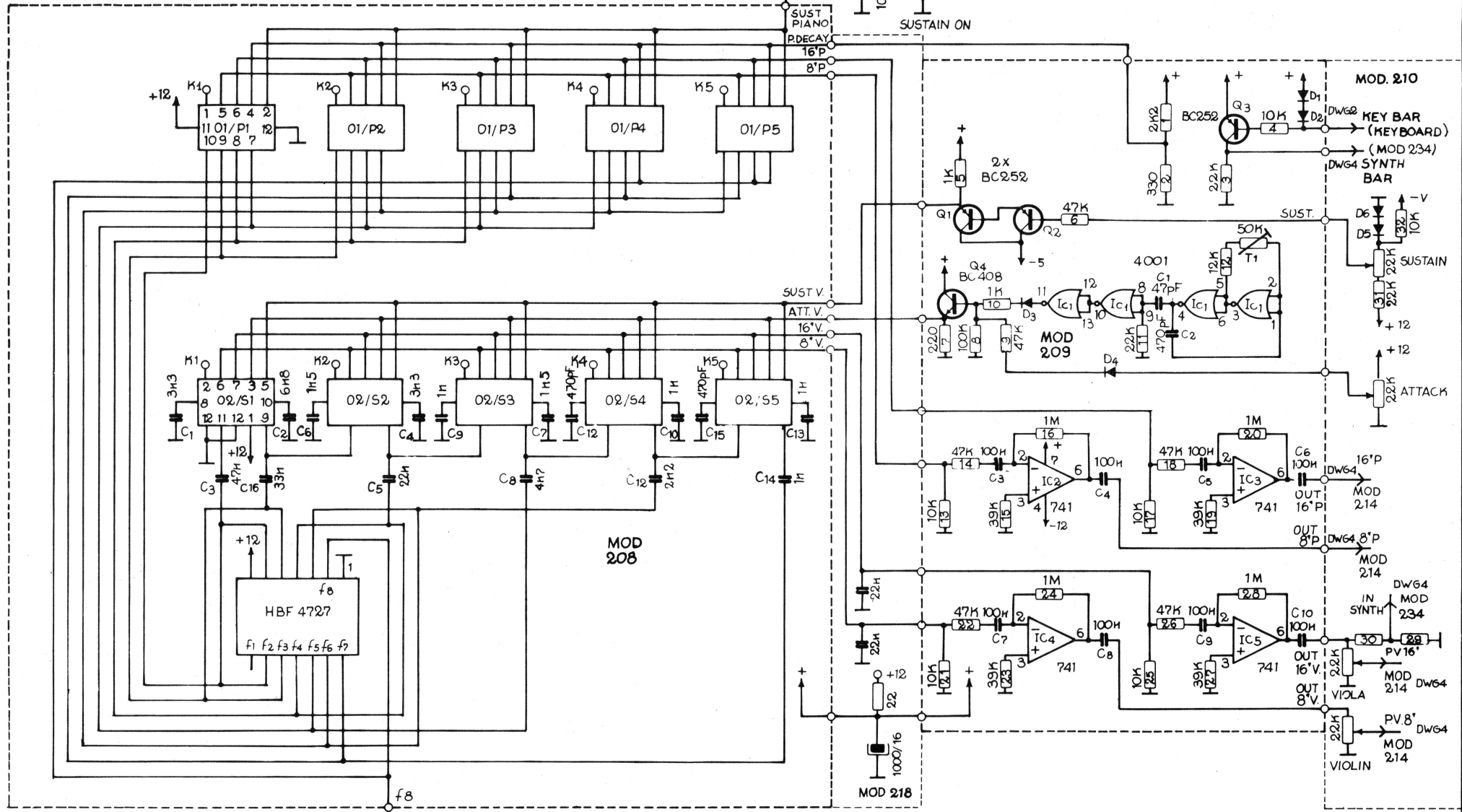
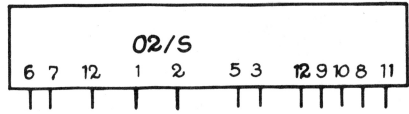
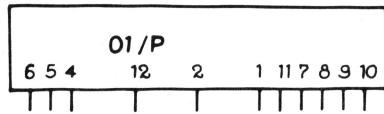

<https://www.servicemanual.altervista.org>

	DWG3	CODE	DATE	REVISION
		PIANO STRINGS SYNTH	<i>[Signature]</i>	OF

MOD 174
DWG 2

+V
 GND
 ATT. P.
 SUST. P.
 SUST. V.
 16' V.
 8' V.
 16' P.
 8' P.
 SYNTH BAR
 -V

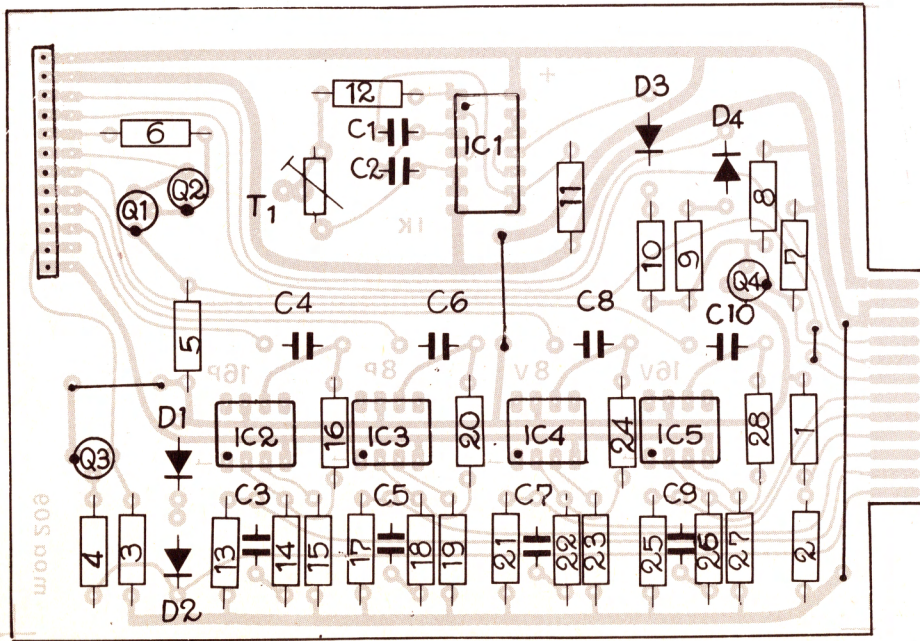

MOD 209

16' P.
 8' P.
 P. DECA
 16' P.
 8' P.
 SUST. V.
 SUST. P.
 ATT. V.
 +V
 GND
 PIANO
 STRINGS
 SUST. V.
 SUST. P.
 16' P.
 8' P.
 16' V.
 8' V.
 +V

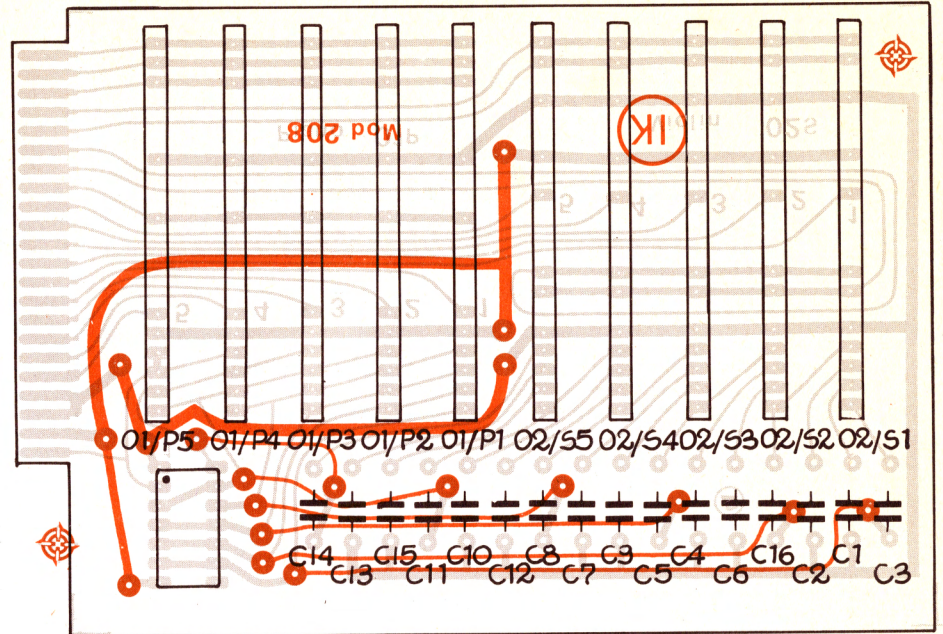

MOD. 208

+V
 GND
 SUST. P.
 ATT. V.
 SUST. V.
 16' V.
 8' V.
 P. DECA
 16' P.
 8' P.
 KEY BAR

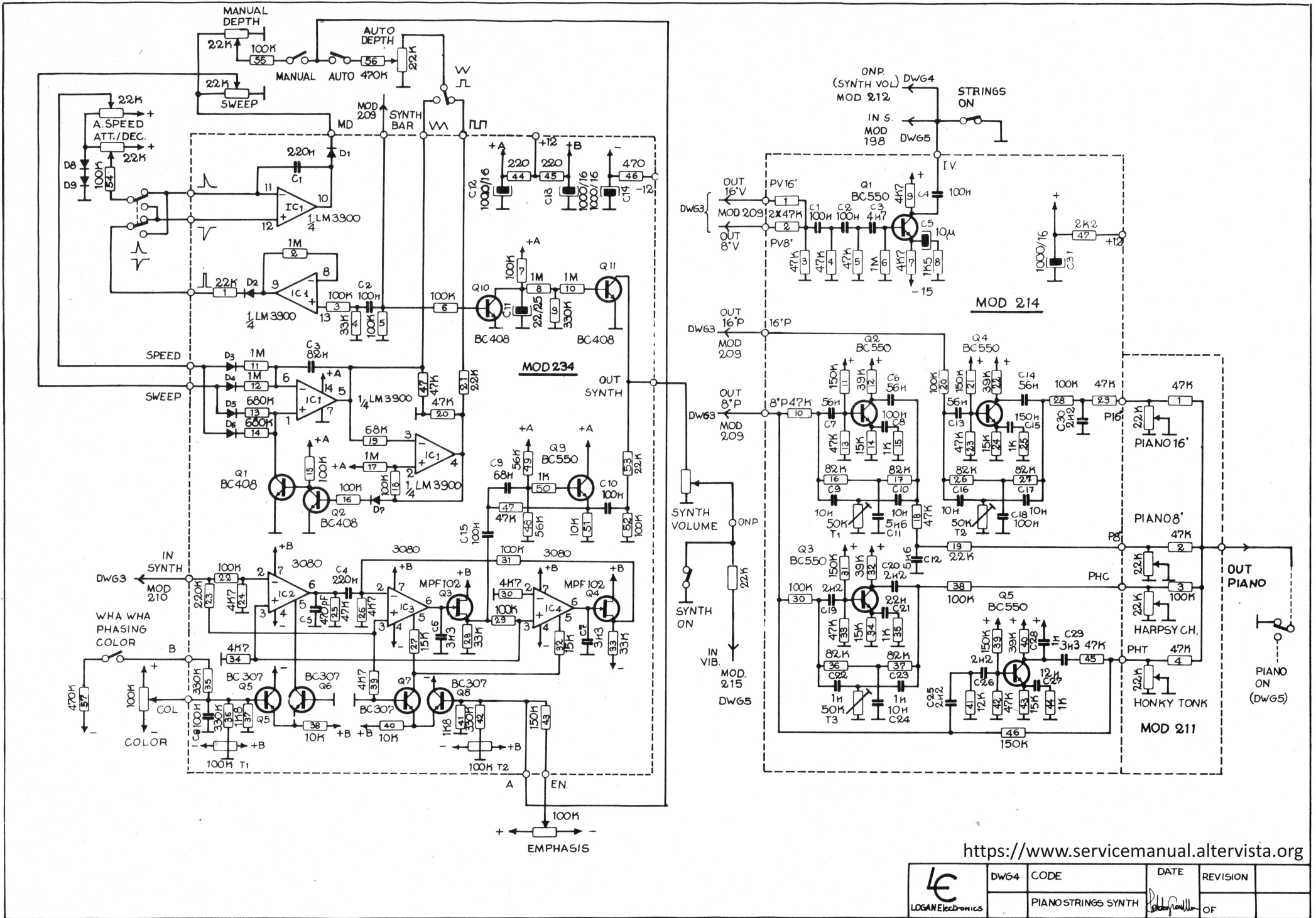

<https://www.servicemanual.altervista.org>

	DWG4	CODE	DATE	REVISION
		PIANO STRINGS SYNTH		OF

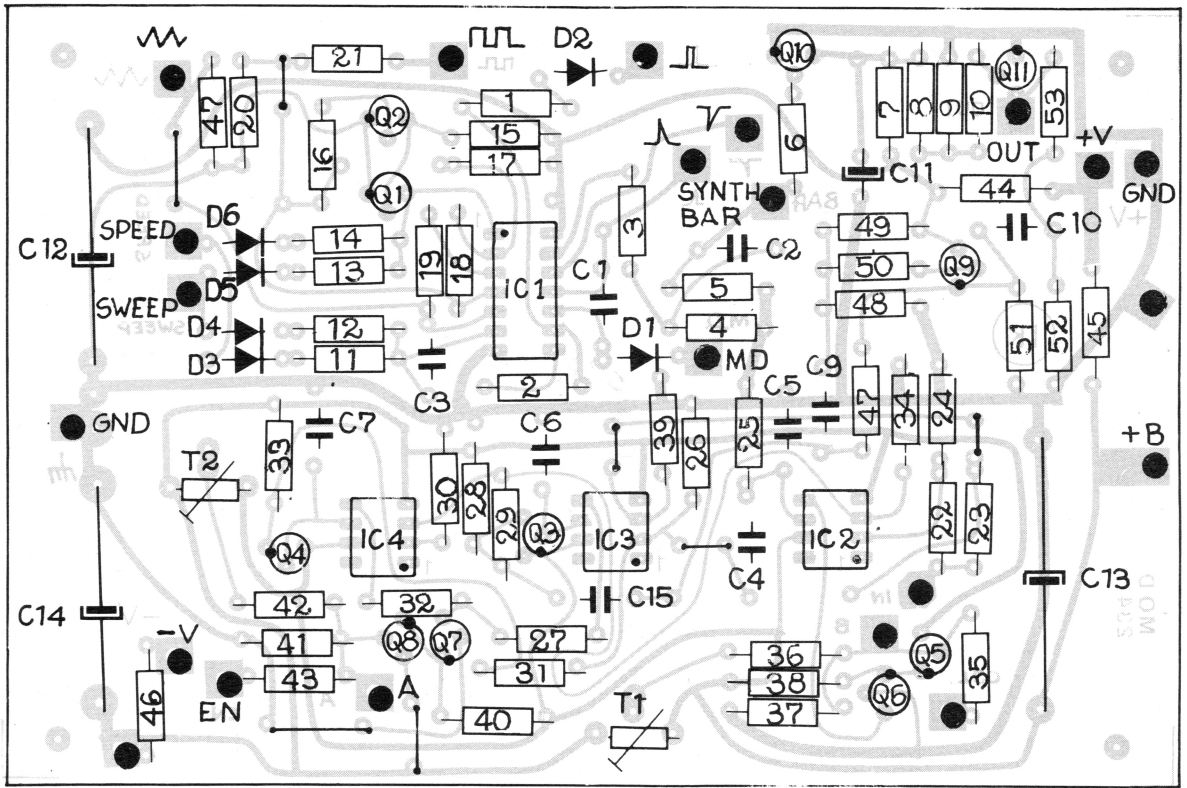

MOD 234

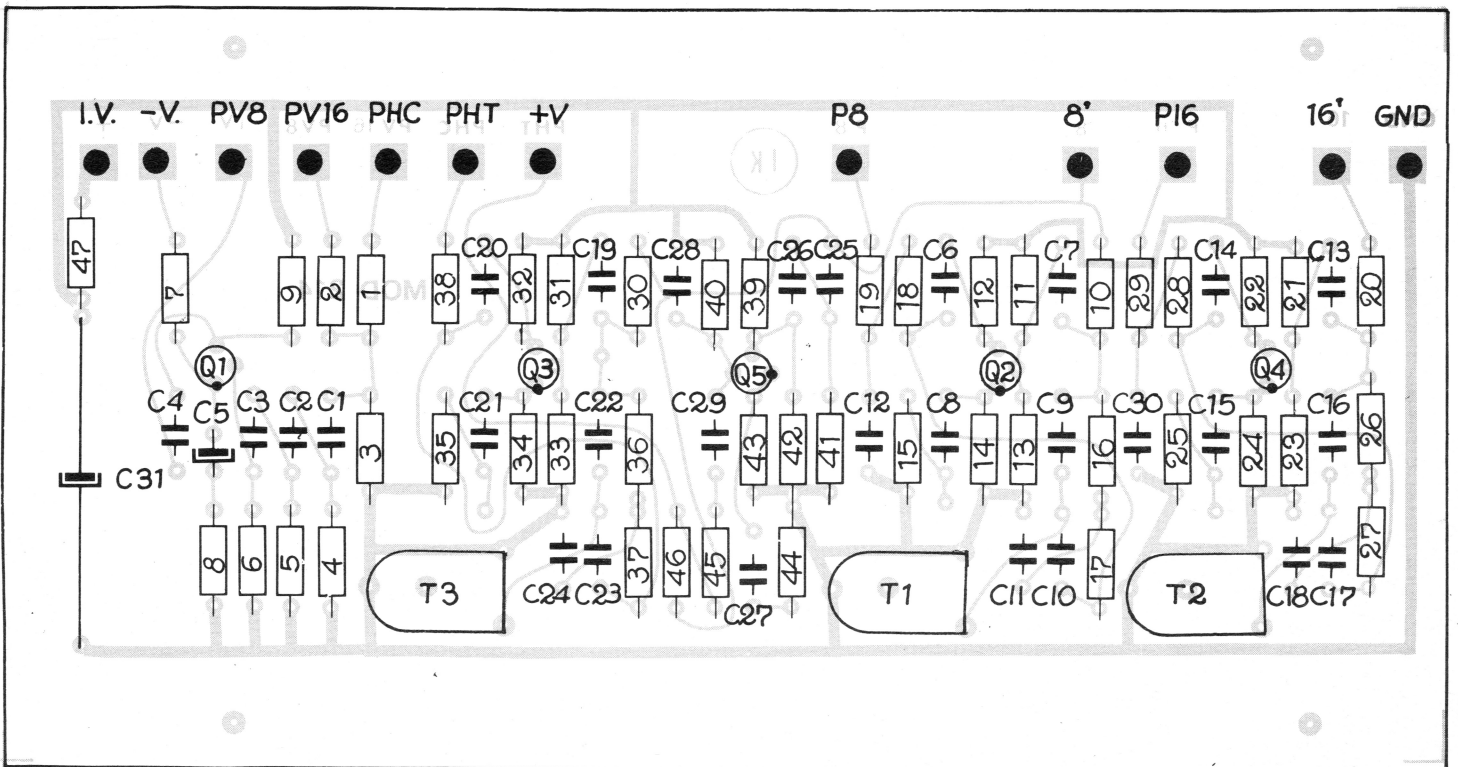

MOD 214

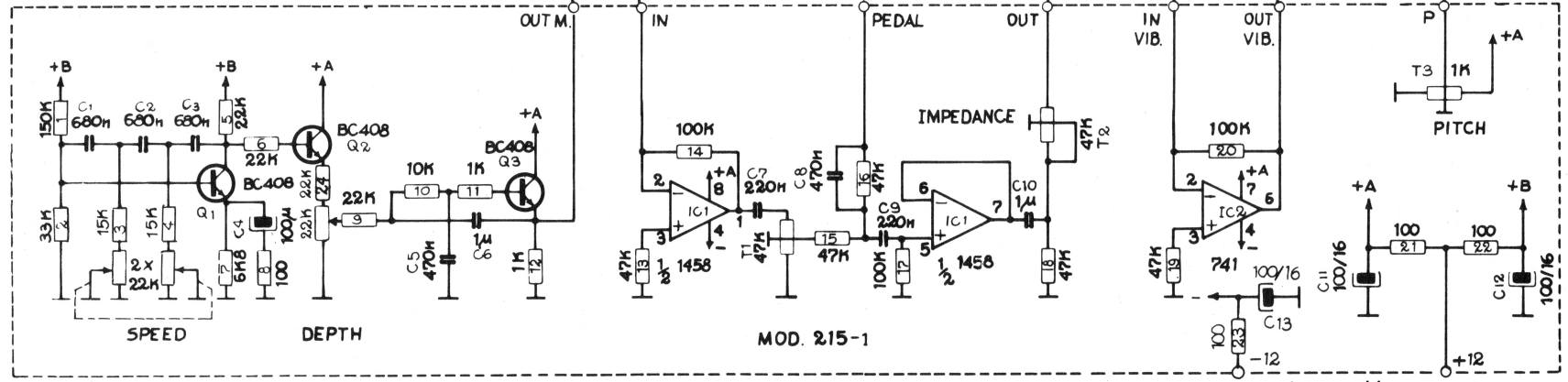
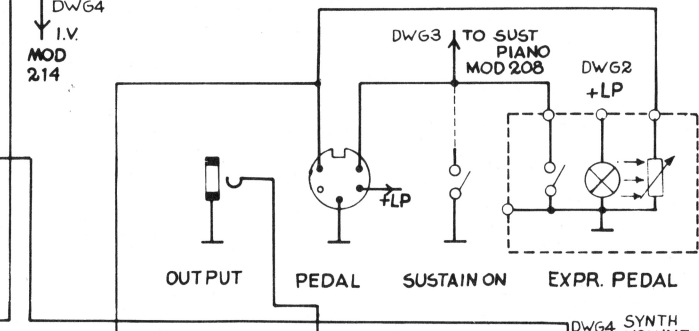
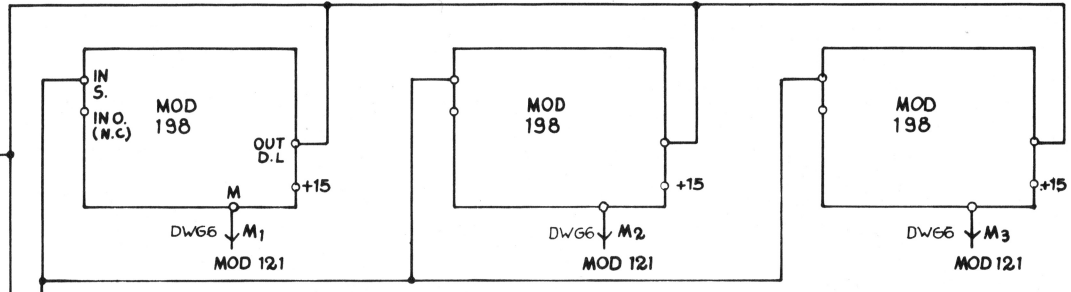
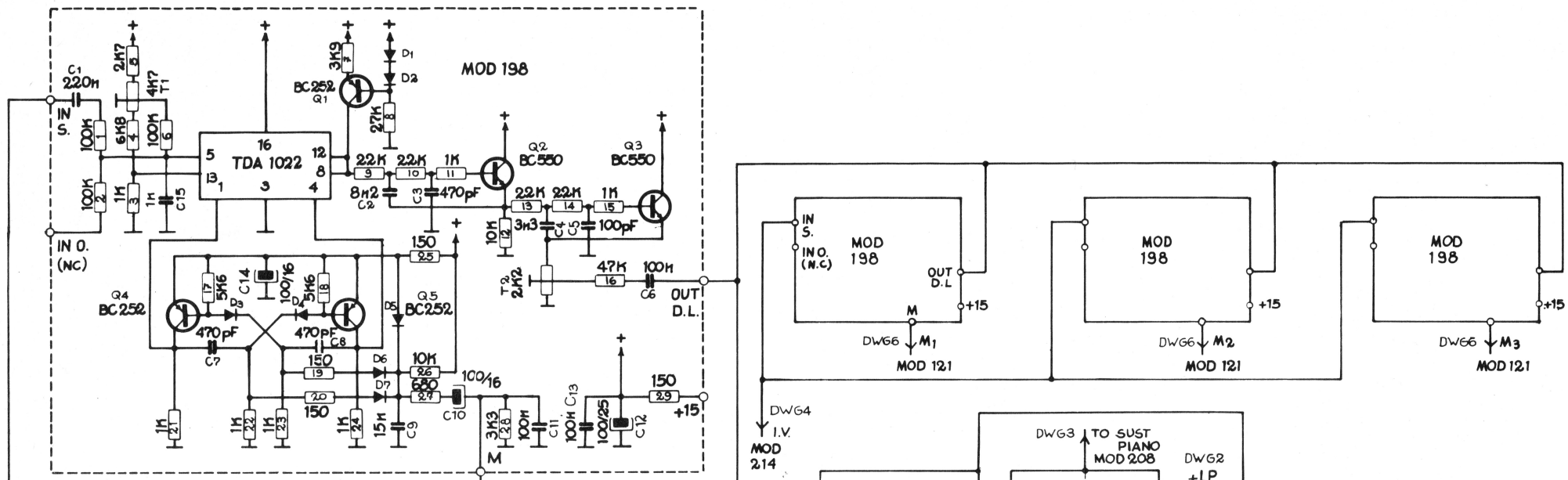

<https://www.servicemanual.altervista.org>

	DWG5	CODE	DATE	REVISION
		PIANO STRINGS SYNTH		OF

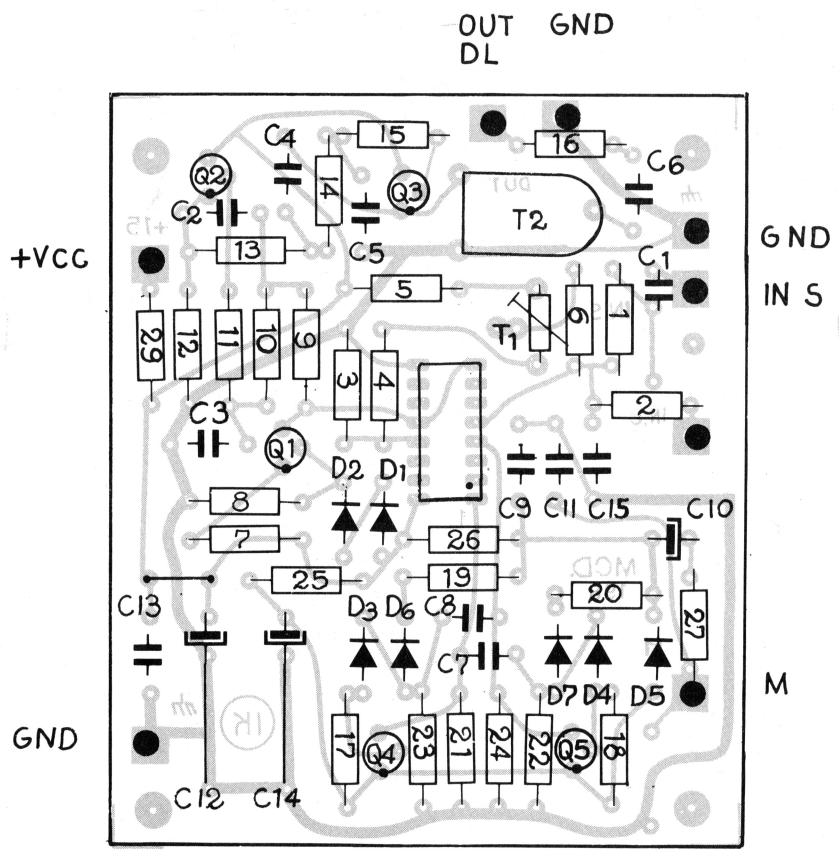

MOD 198

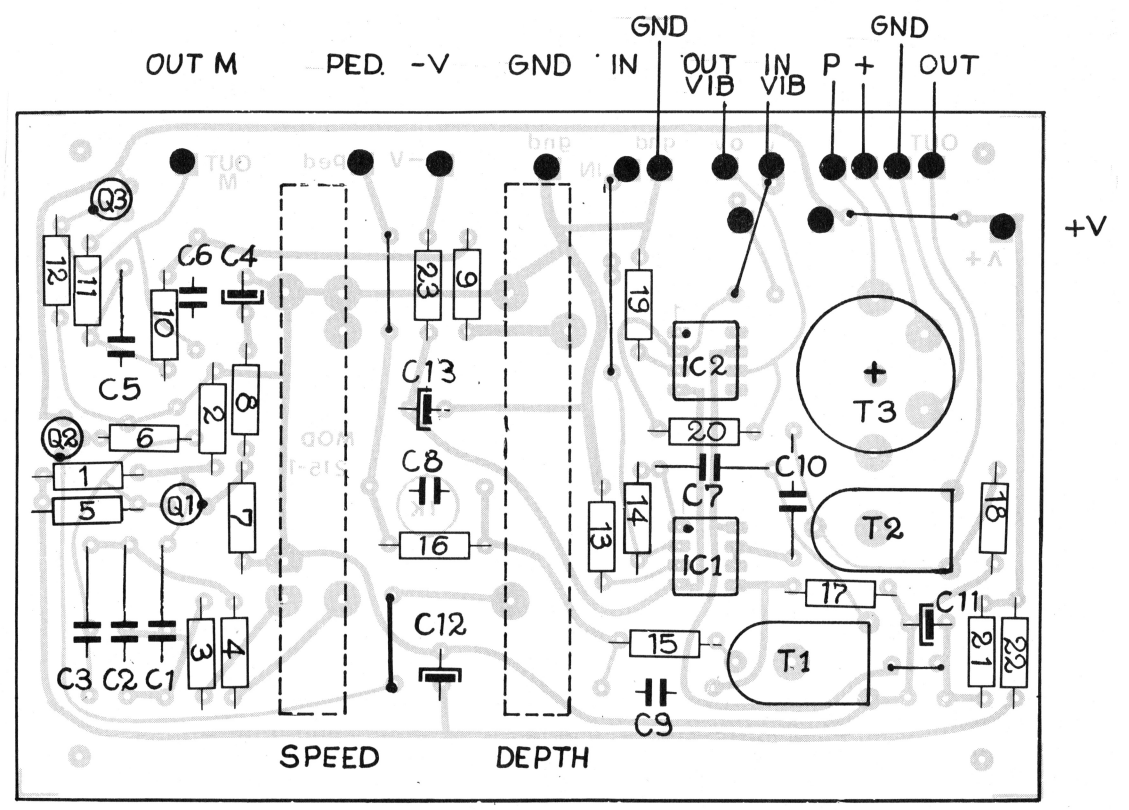

MOD 215-1

MOD 121

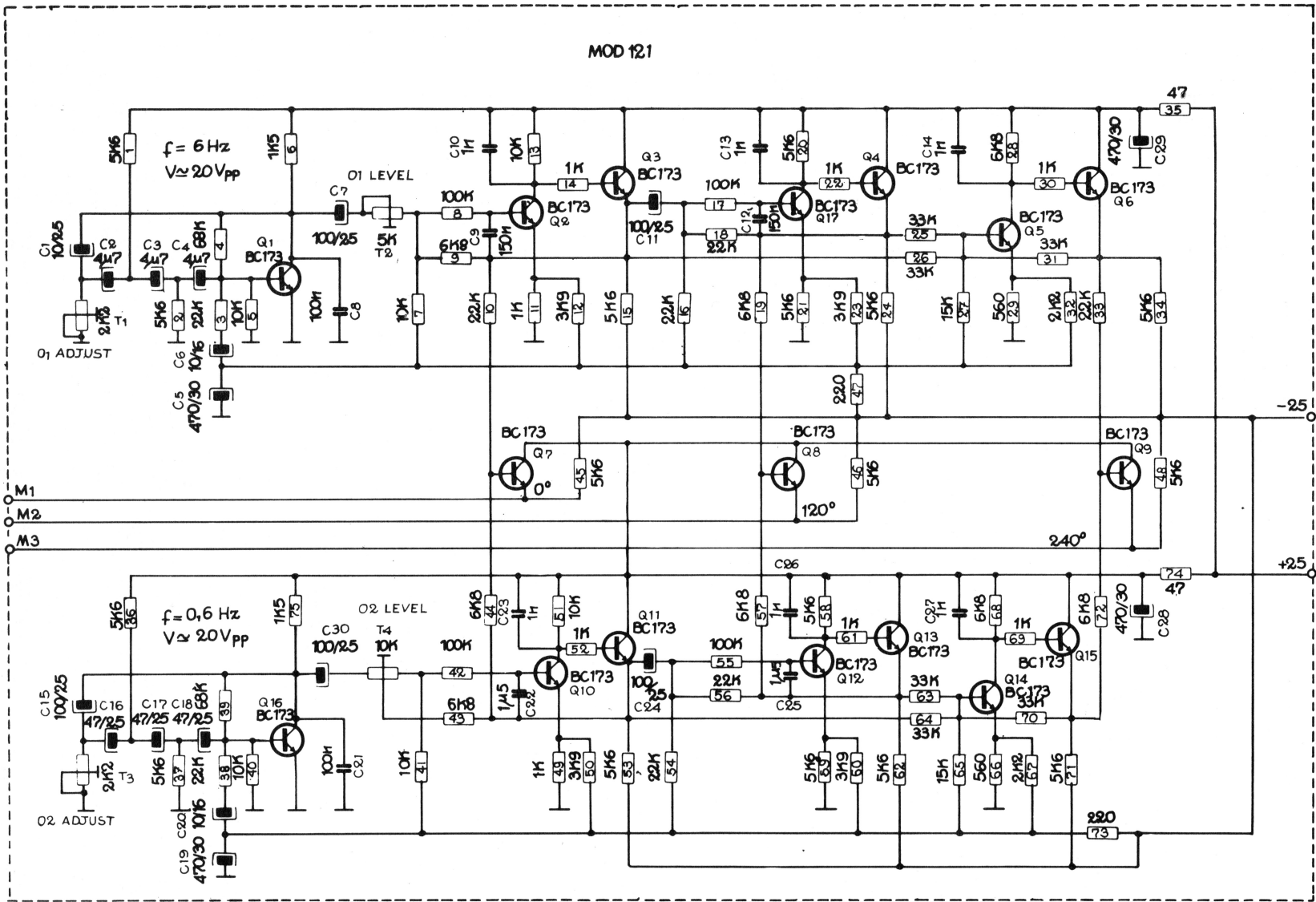

DWG5 MOD 198

<https://www.servicemanual.altavista.org>

	DWG6	CODE	DATE	REVISION
		PIANO STRINGS SYNTH		OF

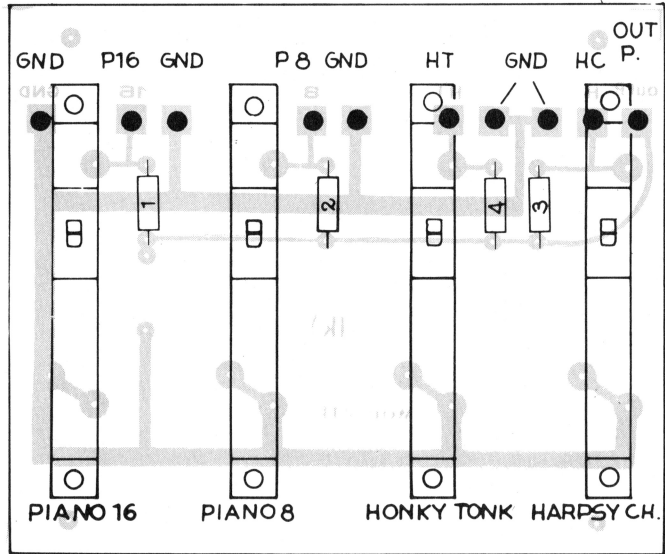

MOD. 211

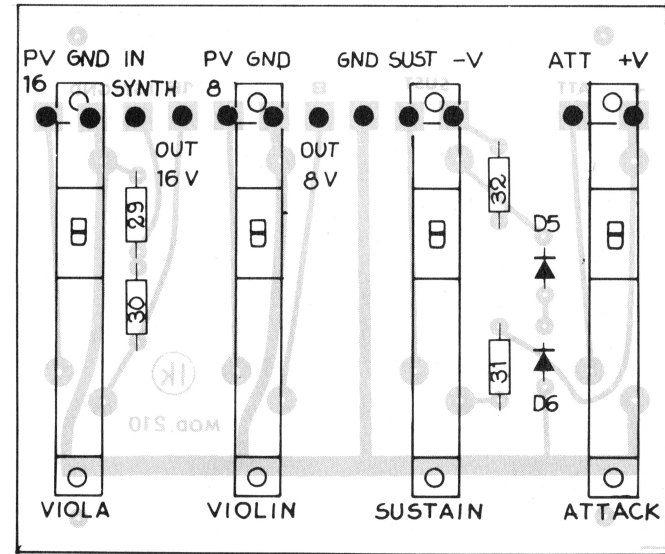

MOD 210

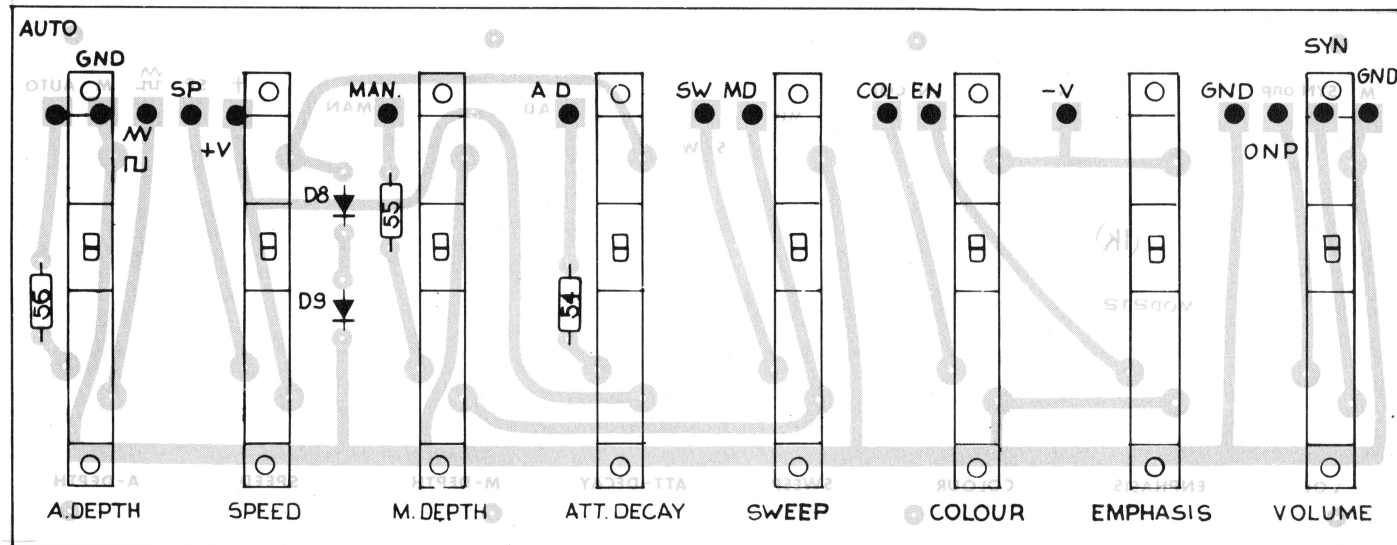

MOD. 212

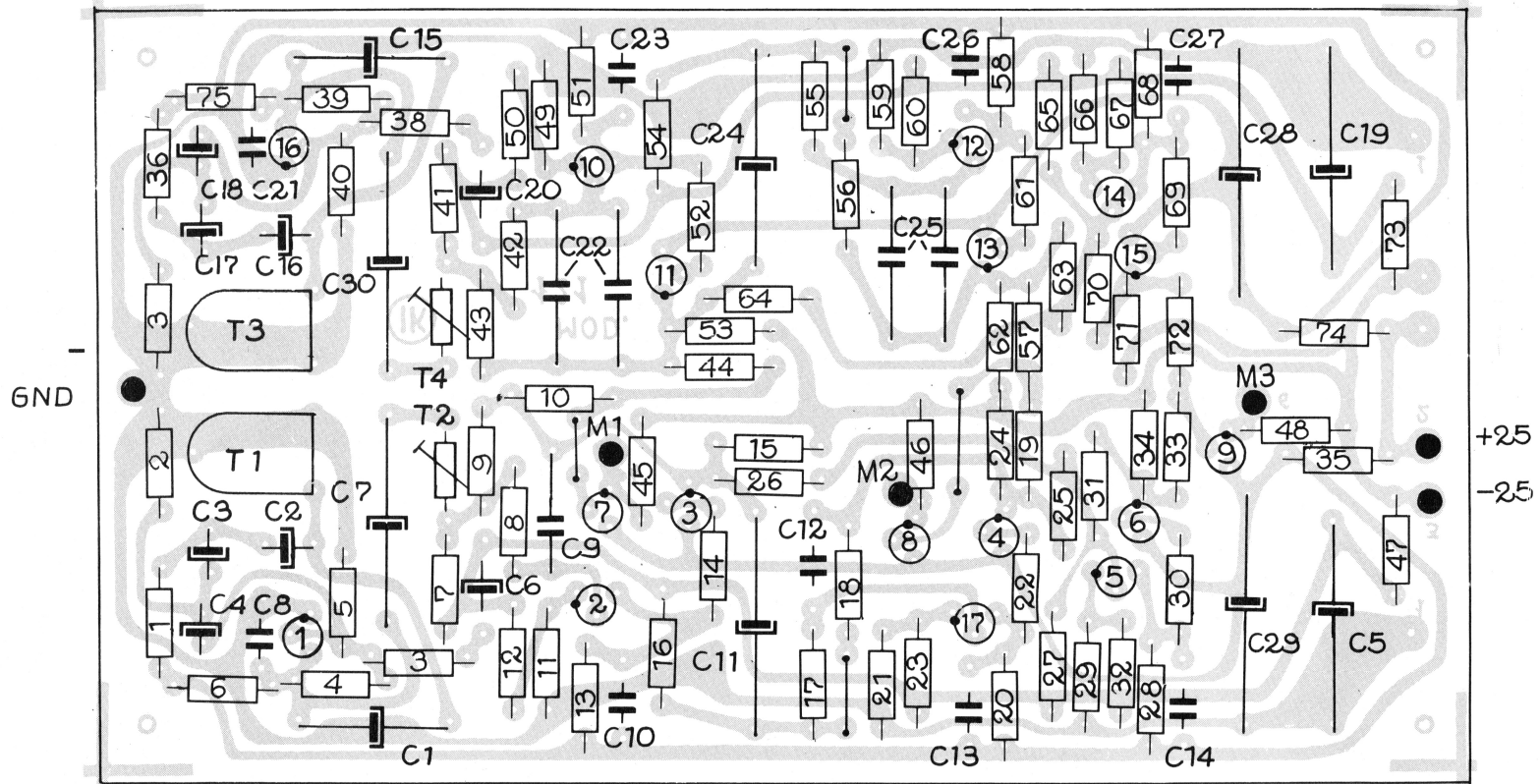

MOD 121

