

REF DESIG	PART NO.	DESCRIPTION
D1, D2, D3	919-041075-001	Diode, 1N4148
IC1, IC2	991-041089-001	Integrated Circuit, 3080T
IC3, IC4, IC5	991-041101-001	Integrated Circuit, 741
Q1, Q4	991-043151-001	Transistor, MPS5172
Q2, Q5, Q6	991-041064-001	FET, N-Channel Junction, 2N4303
Q3	991-041052-001	Transistor, 2N3906
R1	925-043836-001	Potentiometer, Control, Linear, 100K
R2	925-043000-001	Potentiometer, Control, Audio, 2 Meg
R3	925-040275-004	Potentiometer, Trim, Carbon, 10K
R4	925-040275-001	Potentiometer, Trim, Carbon, 100K
SW1	960-040127-001	Switch, SPDT, Push
SW2	960-043044-001	Switch, DPDT, Slide

FILTER - SAMPLE AND HOLD MODEL FSH-1A

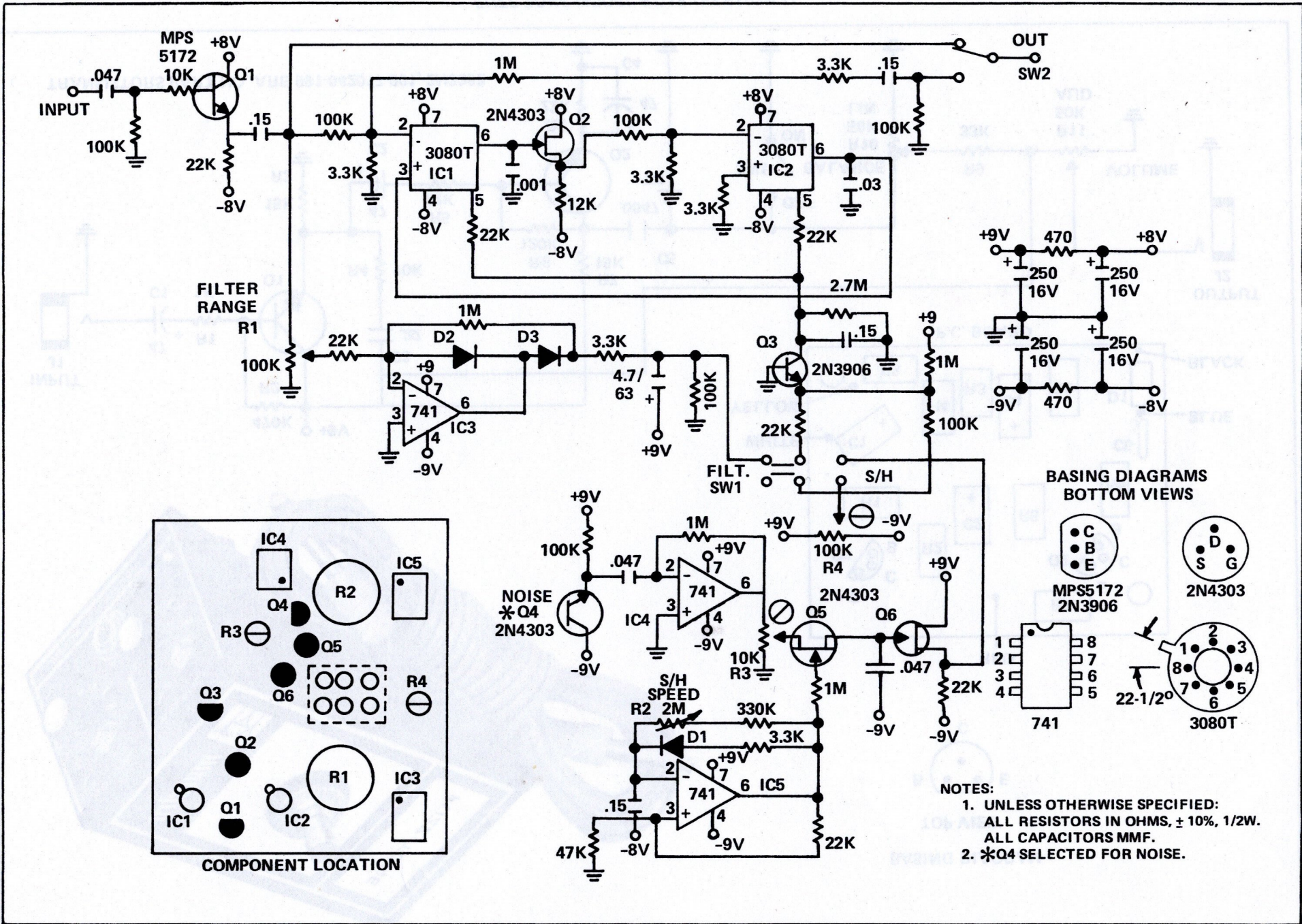

FILTER - SAMPLE AND HOLD MODEL FSH-1A