

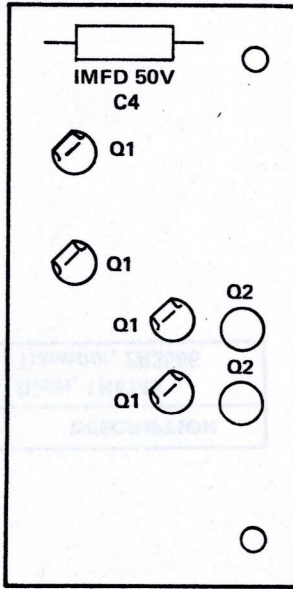

SUPER FUZZ MODEL FZ-1S

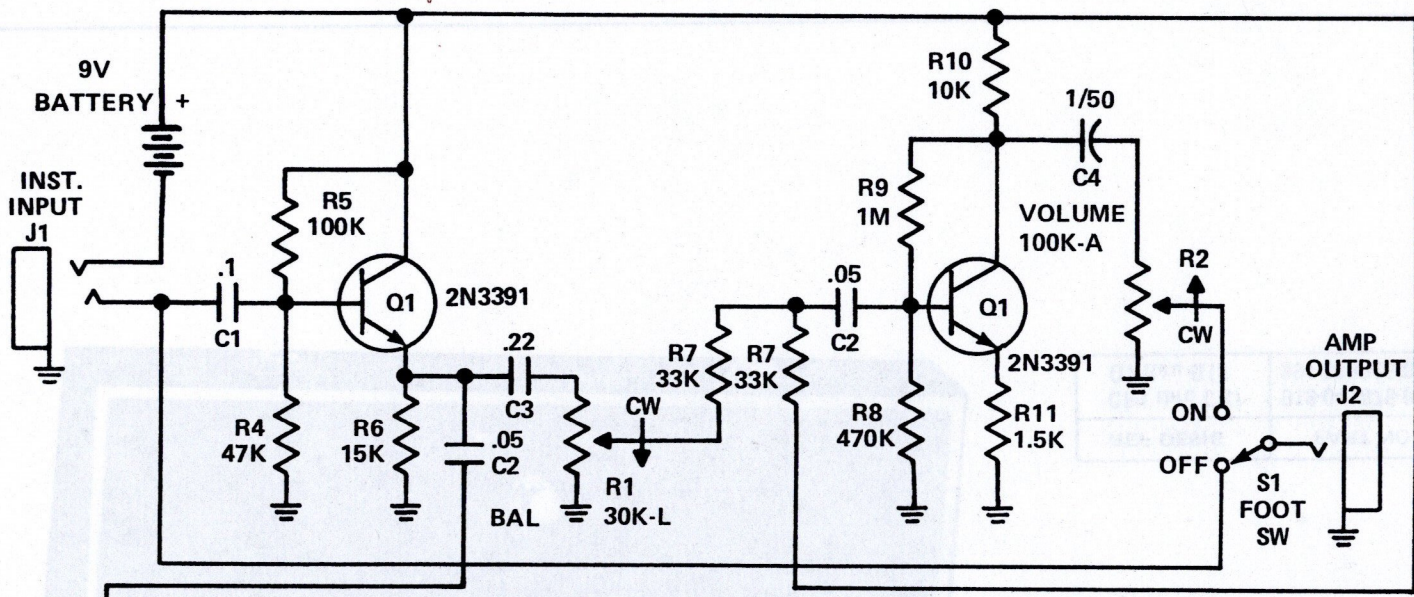

BOARD TOP VIEW

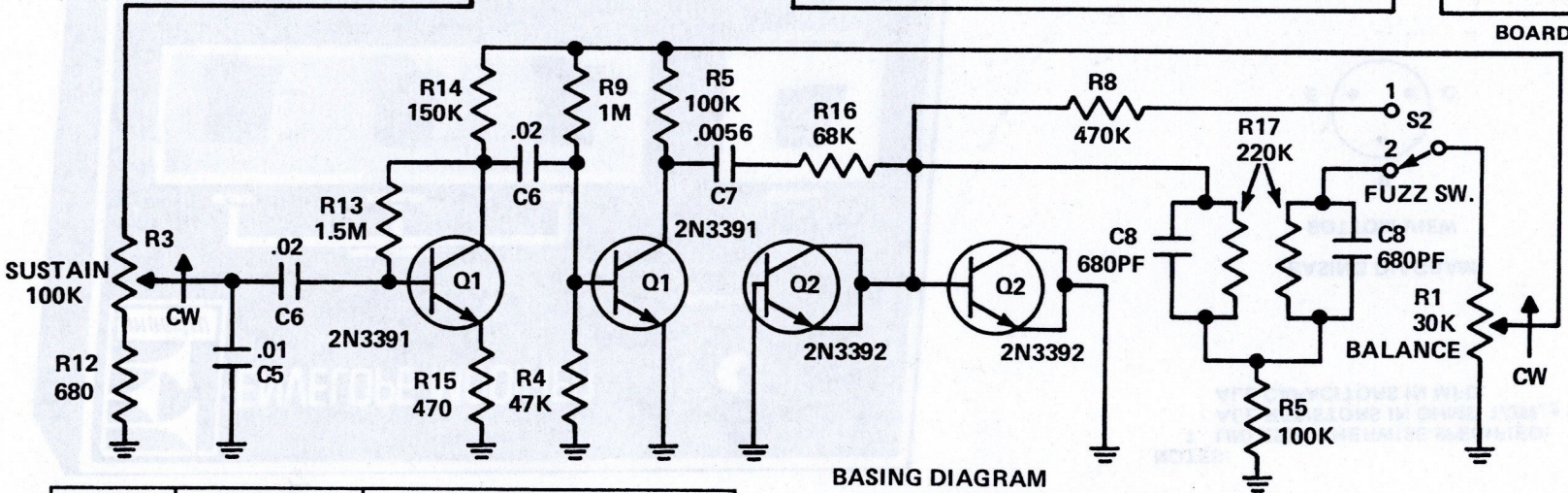

BASING DIAGRAM
BOTTOM VIEW



2N3391
2N3392

REF DESIG	PART NO.	DESCRIPTION
Q1	991-041067-001	Transistor, 2N3391
Q2	991-042017-001	Transistor, 2N3392
R1	925-043002-001	Resistor, Variable, 30K, Dual L Linear
R2	925-043003-001	Resistor, Variable, 100K, Audio
R3	925-043001-001	Resistor, Variable, 100K, Linear
S1	960-040127-001	Switch, Push, SPDT
S2	960-042136-001	Switch, Slide, SPDT

NOTES:
1. UNLESS OTHERWISE SPECIFIED:
ALL RESISTORS IN OHMS, ± 10%, 1/2W.
ALL CAPACITORS IN MFD.