

# TECHNICAL SERVICE MANUAL for

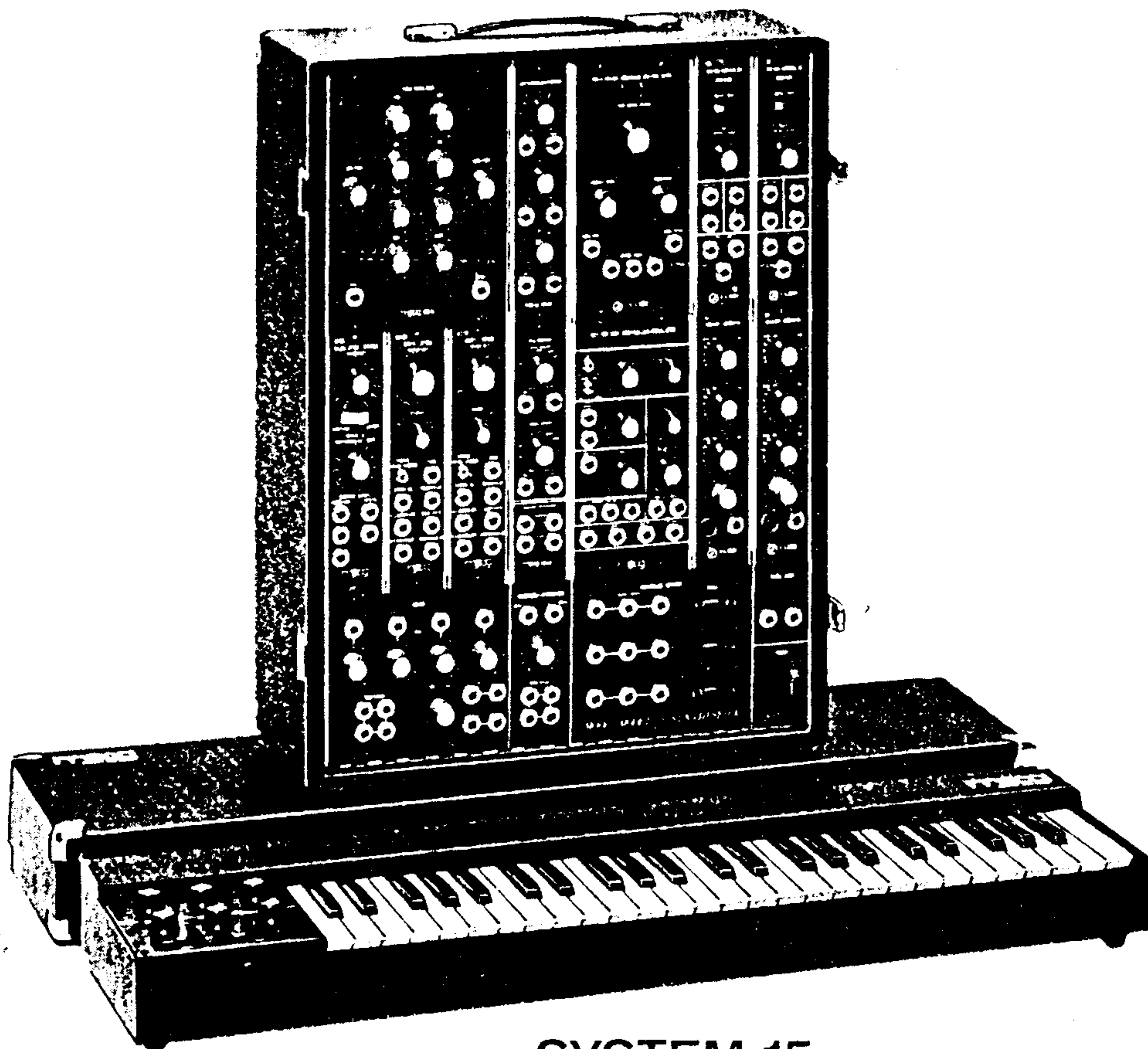

SYSTEM 15

INCLUDES  
MODULES FROM

SYSTEM I  
SYSTEM II  
SYSTEM III  
SYSTEM 12  
SYSTEM 15  
SYSTEM 35  
SYSTEM 55



NORLIN MUSIC  
(716) 681-7242

2500 Walden Ave.  
Buffalo, N.Y. 14225

NOTE: TRANSFORMER PHASING FOR PROPER OPERATION.

+12, G, -6V

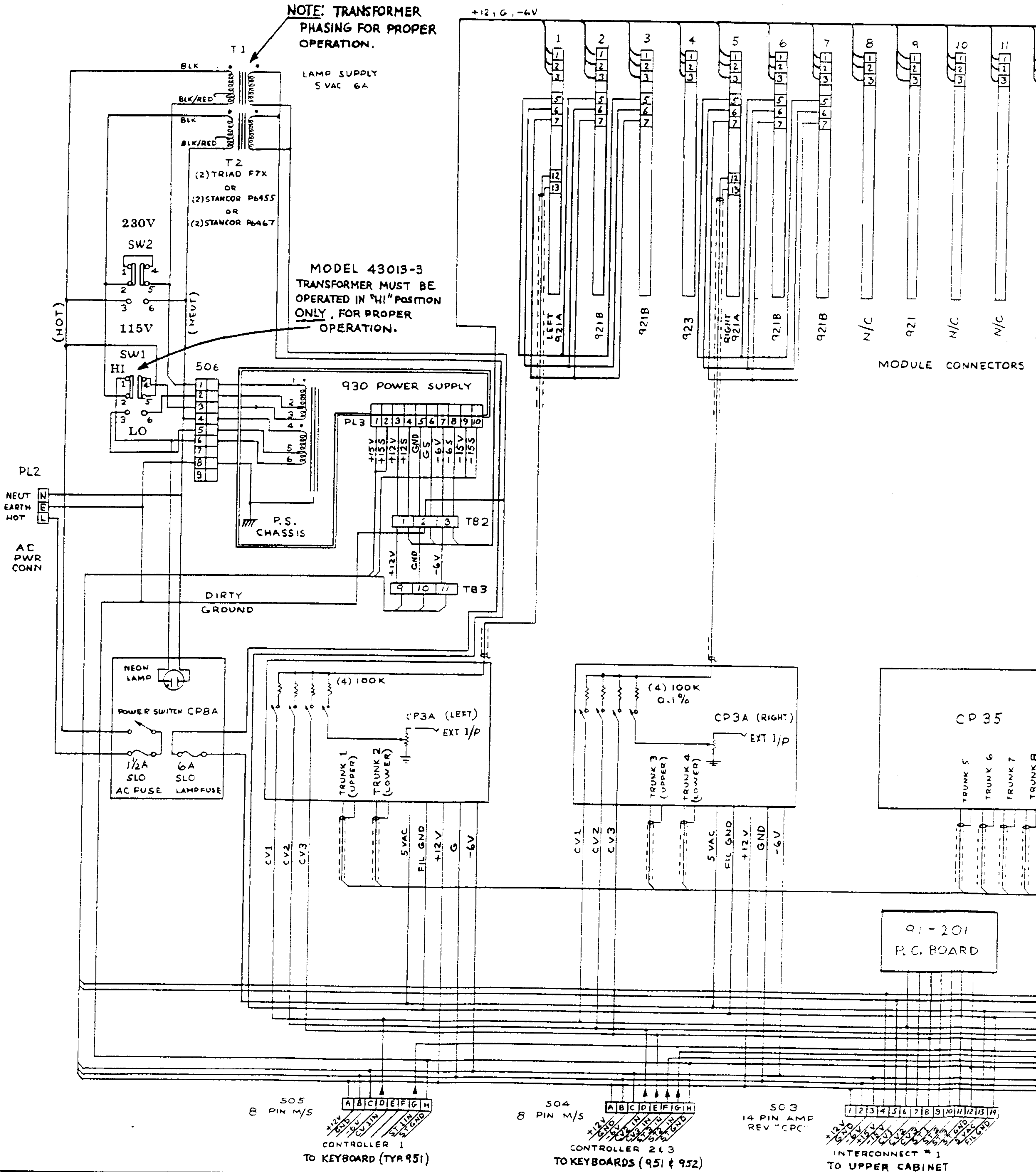

LAMP SUPPLY  
5 VAC 6A

T 2  
(2) TRIAD F7X  
OR  
(2) STANCOR P6455  
OR  
(2) STANCOR P6467

MODEL 43013-3  
TRANSFORMER MUST BE  
OPERATED IN "HI" POSITION  
ONLY, FOR PROPER  
OPERATION.

930 POWER SUPPLY

PL3 1 2 3 4 5 6 7 8 9 10  
+15V  
+12V  
+12S  
GND  
-6V  
-6S  
-15V  
-15S

P.S.  
CHASSIS

TB2 1 2 3

TB3 9 10 11

DIRTY  
GROUND

NEON LAMP  
POWER SWITCH CPBA

1/2A SLO AC FUSE  
6A SLO LAMP FUSE

(4) 100K  
CP3A (LEFT)  
EXT 1/P  
TRUNK 1 (UPPER)  
TRUNK 2 (LOWER)

(4) 100K  
0.1%  
CP3A (RIGHT)  
EXT 1/P  
TRUNK 3 (UPPER)  
TRUNK 4 (LOWER)

CP 35  
TRUNK 5  
TRUNK 6  
TRUNK 7  
TRUNK 8

91-201  
P.C. BOARD

505  
8 PIN M/S  
A B C D E F G H  
+12V  
GND  
-6V  
+12V  
GND  
-6V  
CONTROLLER 1  
TO KEYBOARD (TYP 951)

504  
8 PIN M/S  
A B C D E F G H  
+12V  
GND  
-6V  
+12V  
GND  
-6V  
CONTROLLER 2 & 3  
TO KEYBOARDS (951 & 952)

503  
14 PIN AMP  
REV "CPC"  
1 2 3 4 5 6 7 8 9 10 11 12 13 14  
+12V  
GND  
-6V  
+12V  
GND  
-6V  
INTERCONNECT \* 1  
TO UPPER CABINET

MODULE CONNECTORS

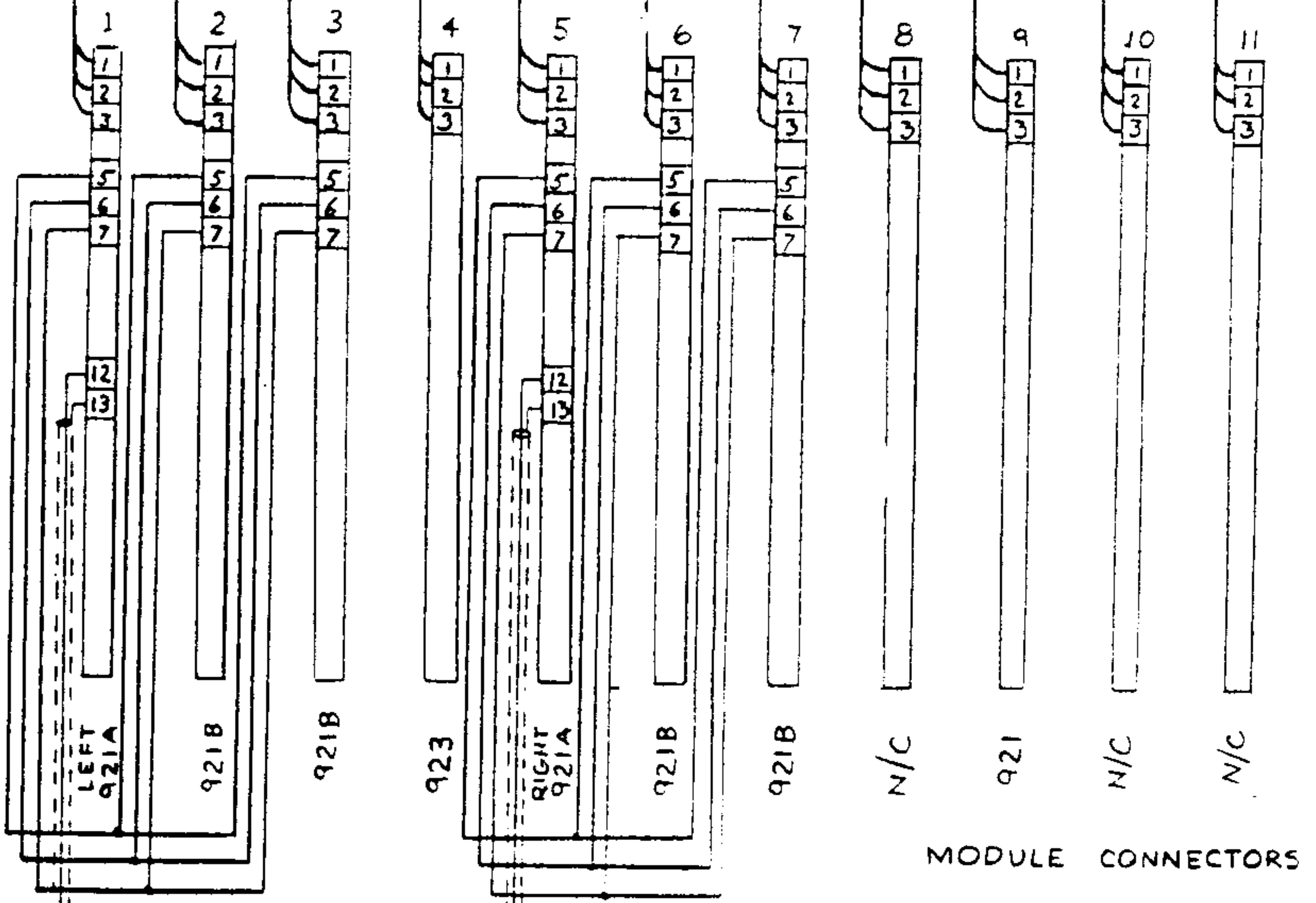

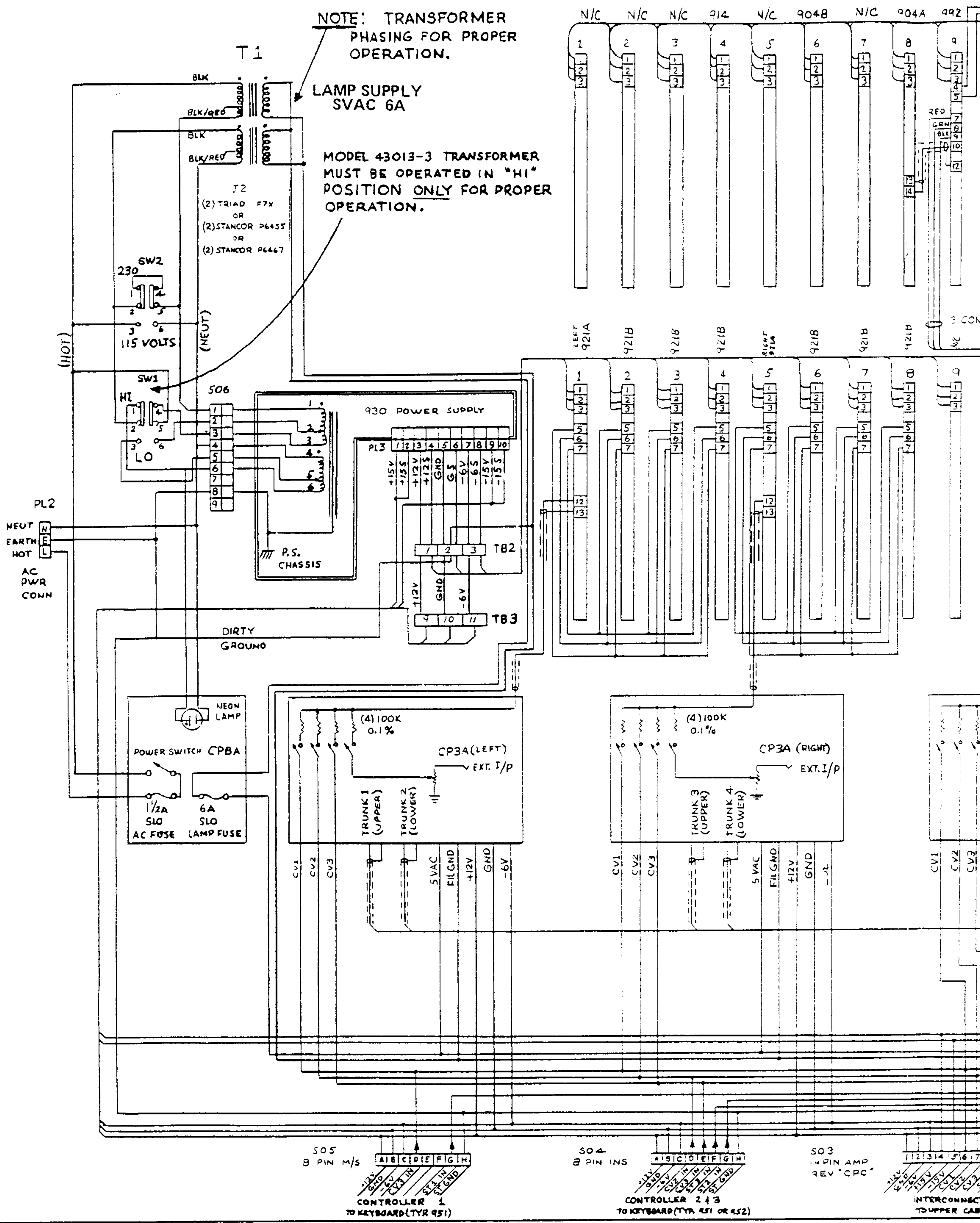
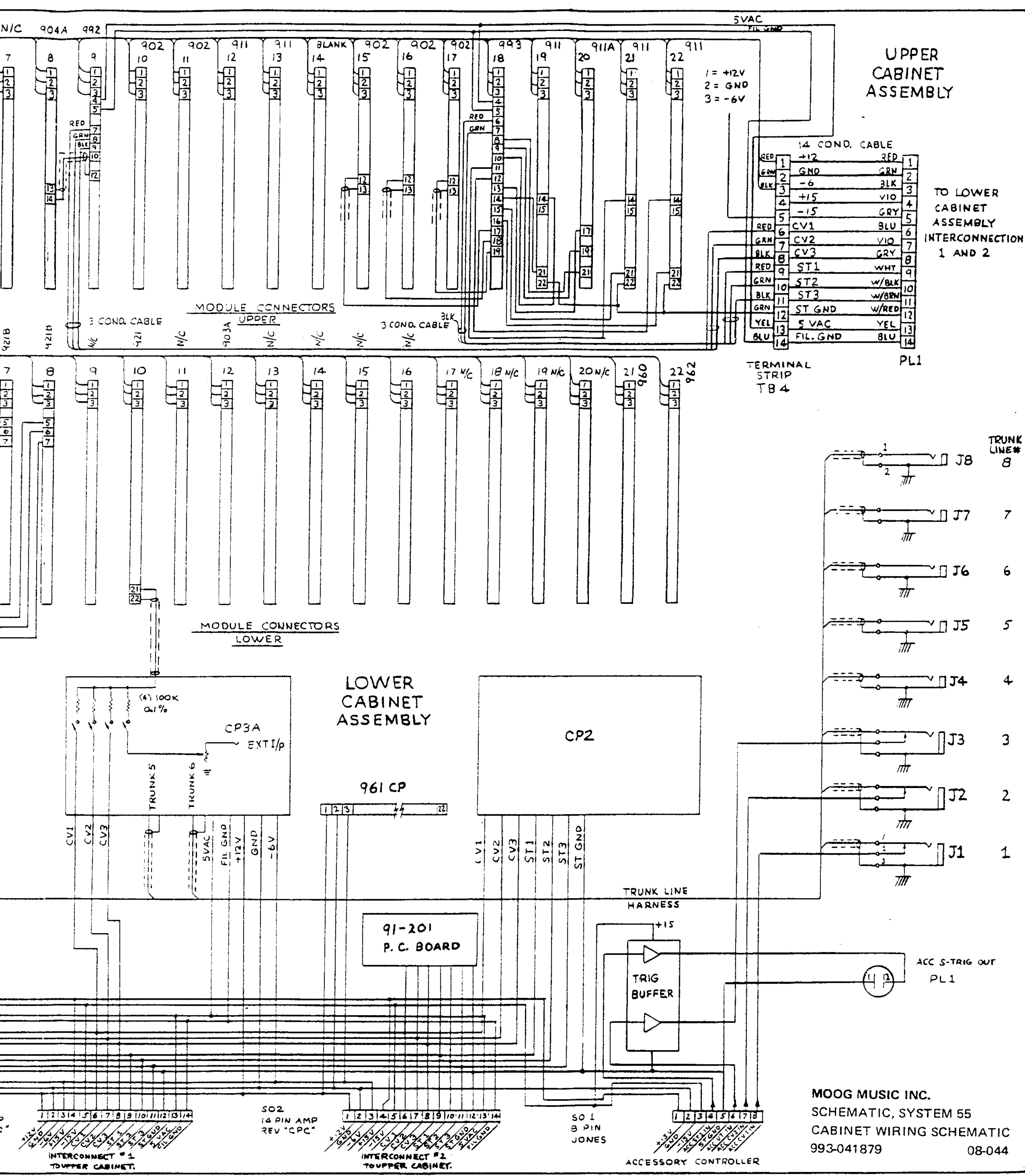
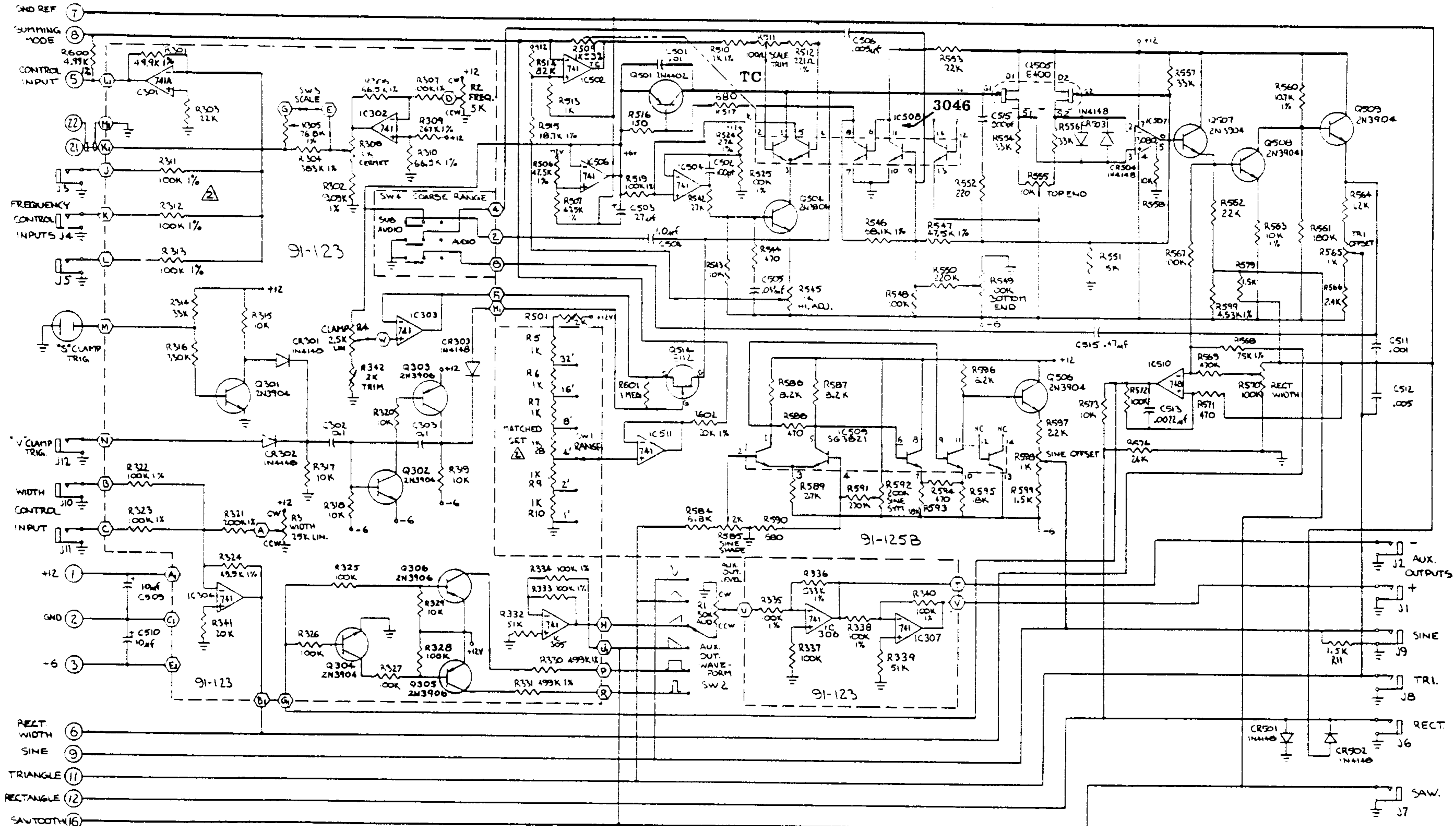
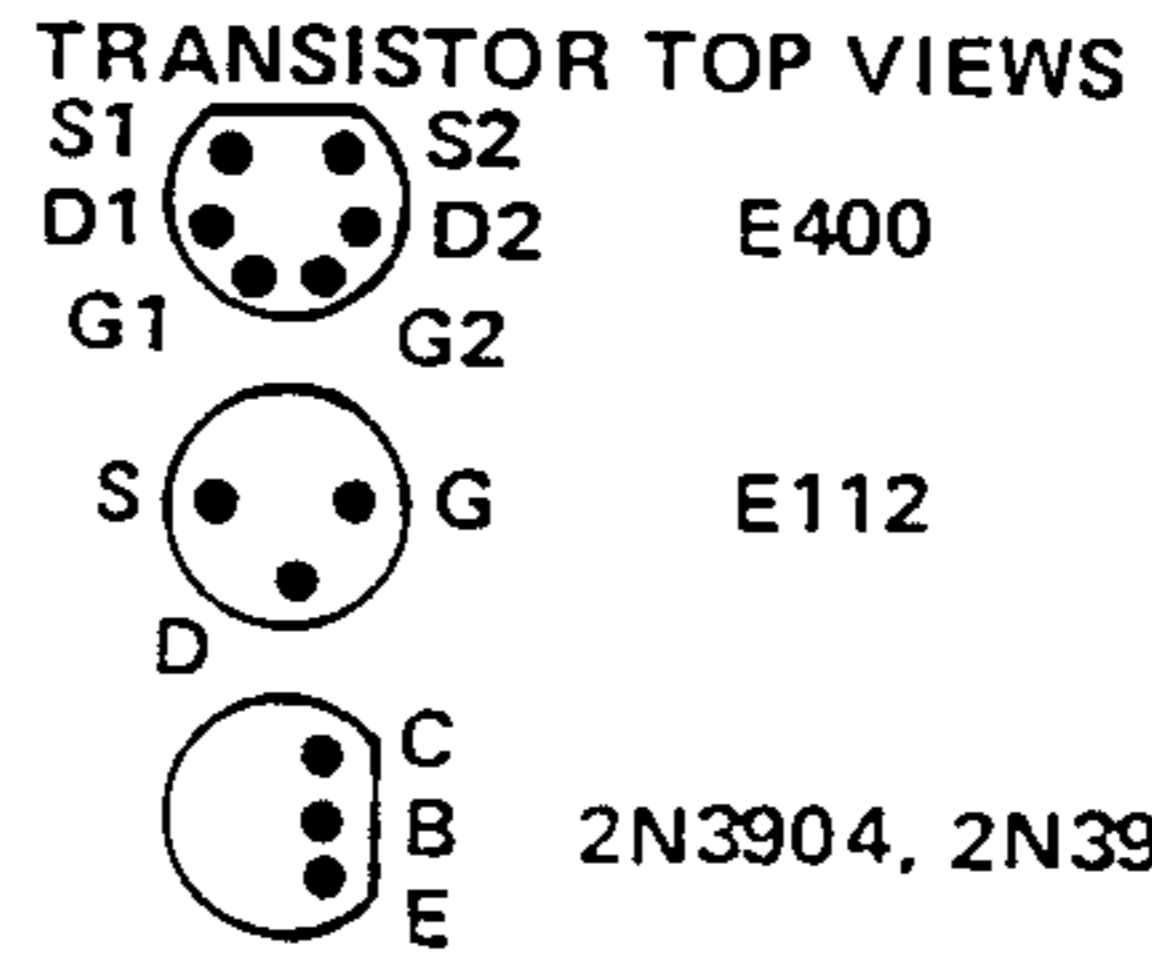
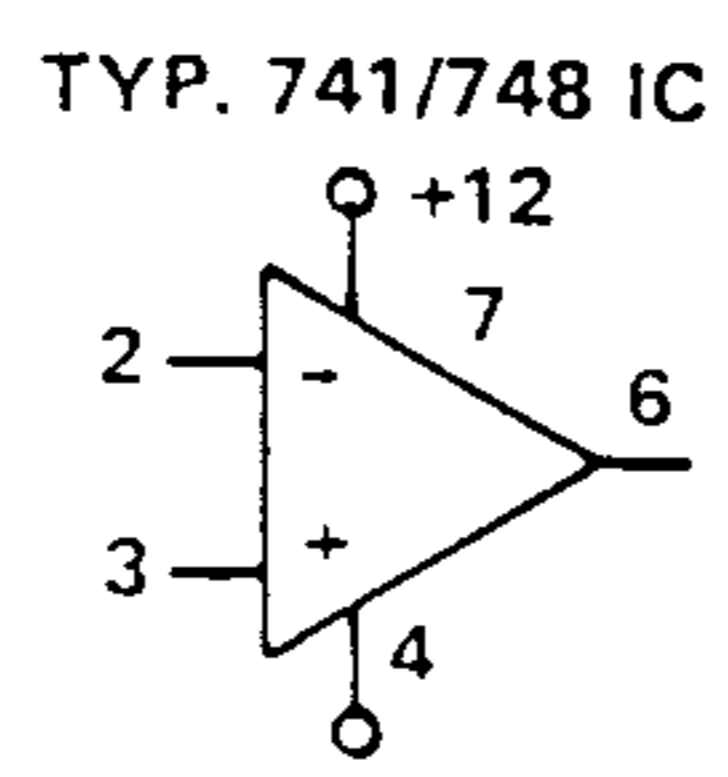

FIGURE 48 CABINET WIRING, SYSTEM 55





- NOTES:**
- ⚠ ALL RESISTORS 5%, 1/2 WATT UNLESS OTHERWISE NOTED
  - ⚠ 1% RESISTORS MATCHED TO 0.1%
  - ⓧ DESIGNATES REAR CONNECTOR NUMBER (PCB 91-125)
  - ⓧ DESIGNATES P/C BOARD INTERCONNECTIONS



**COMPONENT DESIGNATORS**

NO PREFIX → FRONT PANEL  
 3XX → 93 - 123 PCB ASST  
 5XX, 6XX → 93 - 126 PCB ASST

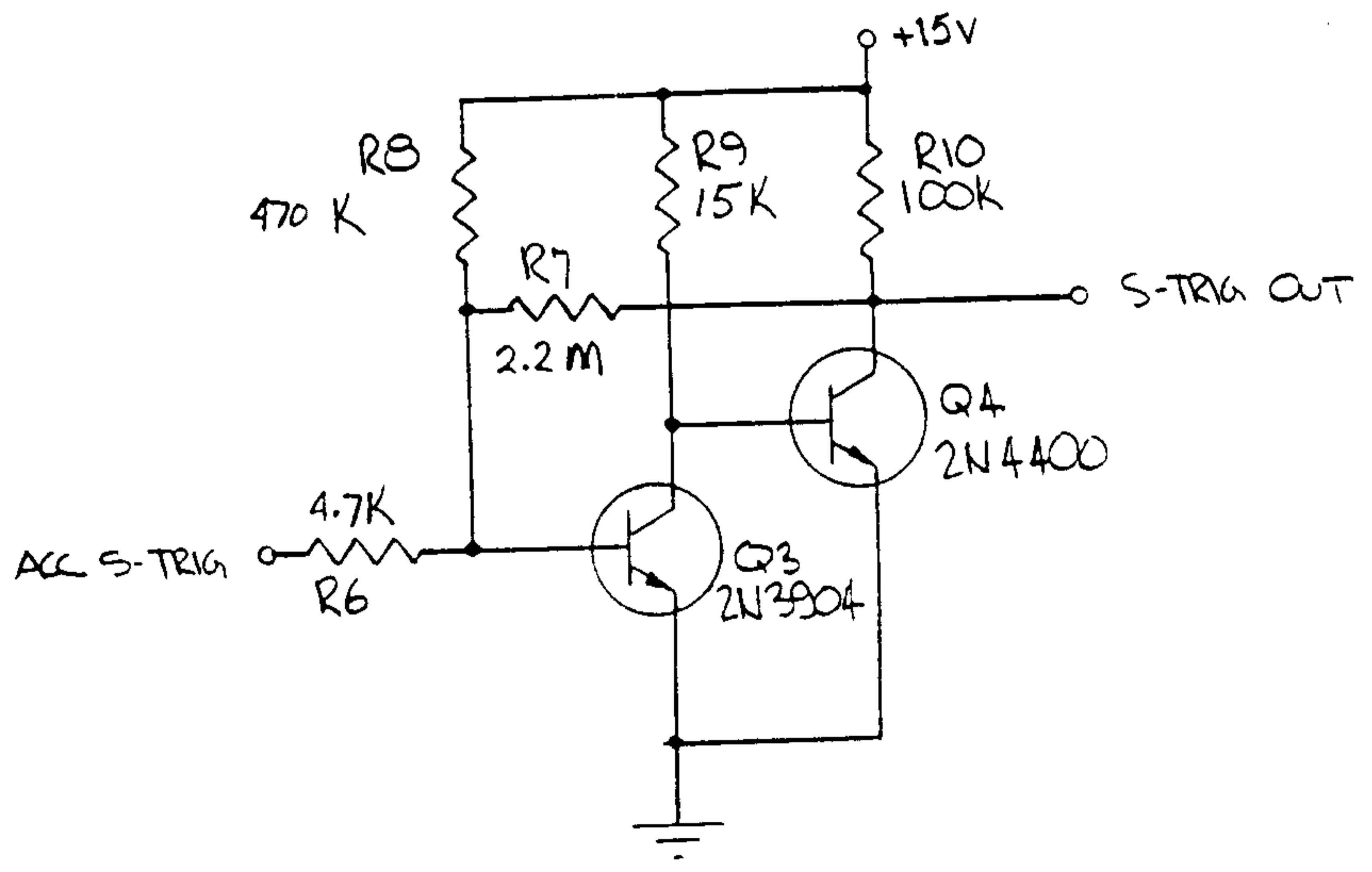
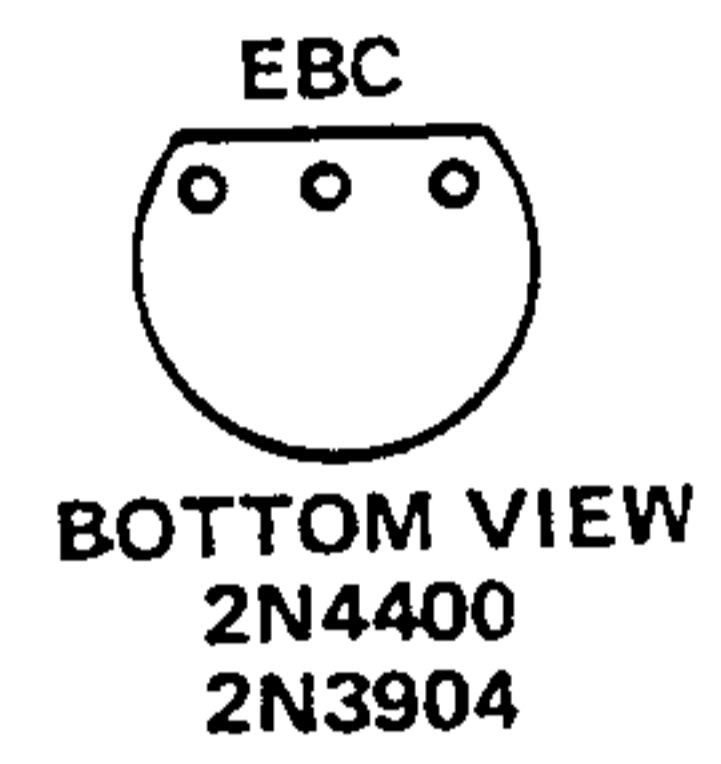
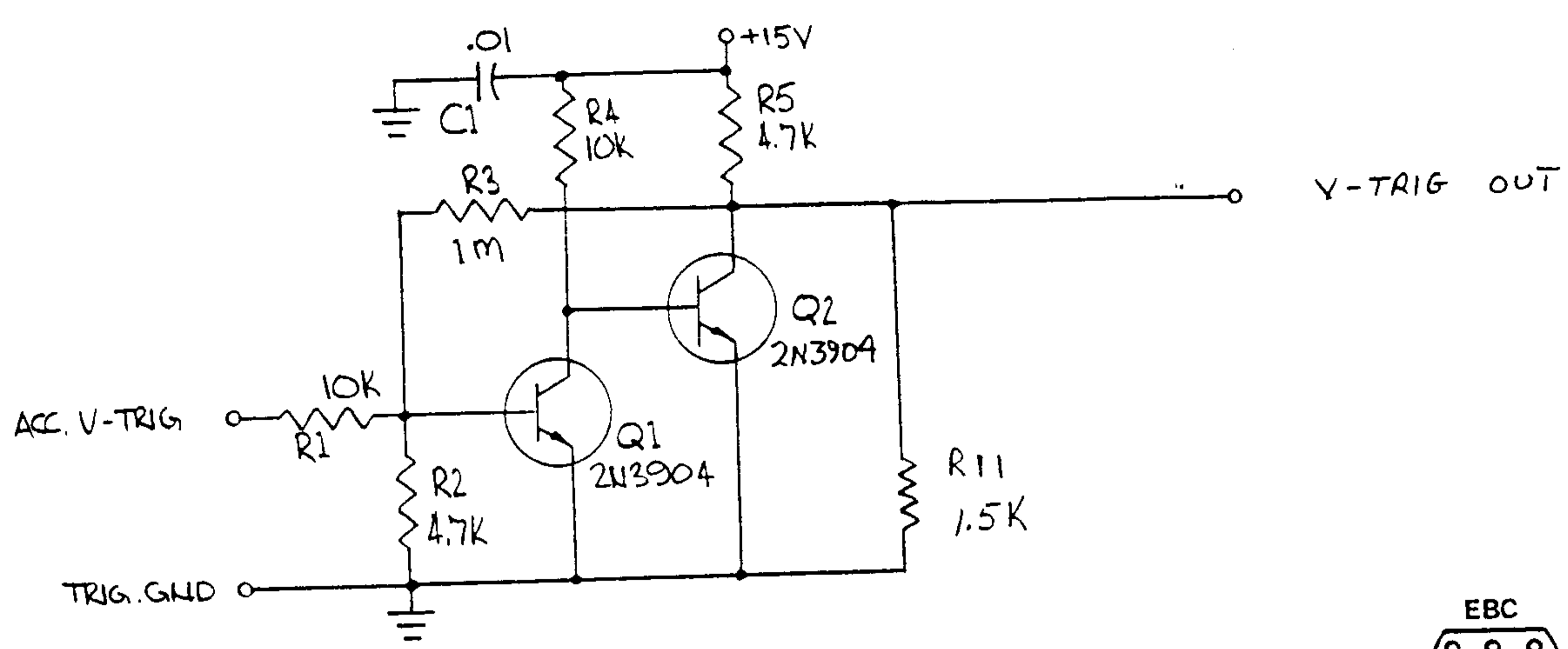

MOOG MUSIC INC.  
 SCHEMATIC, TRIGGER BUFFER-35/55  
 993-041778 08-046

FIGURE 45 TRIGGER BUFFER, SYSTEMS 35/55

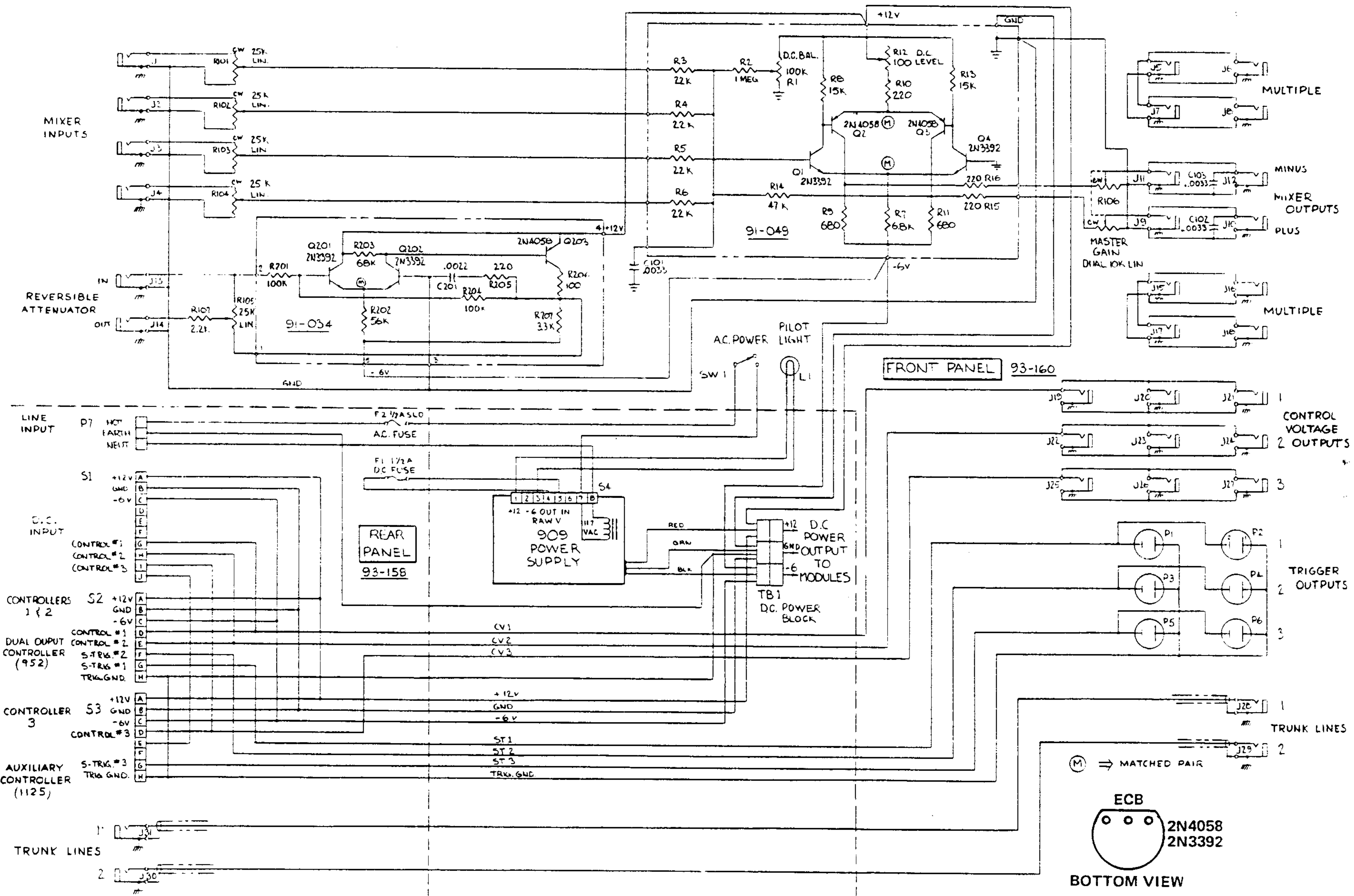

MOOG MUSIC INC.  
 SCHEMATIC, INTERCONNECT SYN. 15  
 993-091817 08-035

FIGURE 43 INTERCONNECTION SYSTEM 15

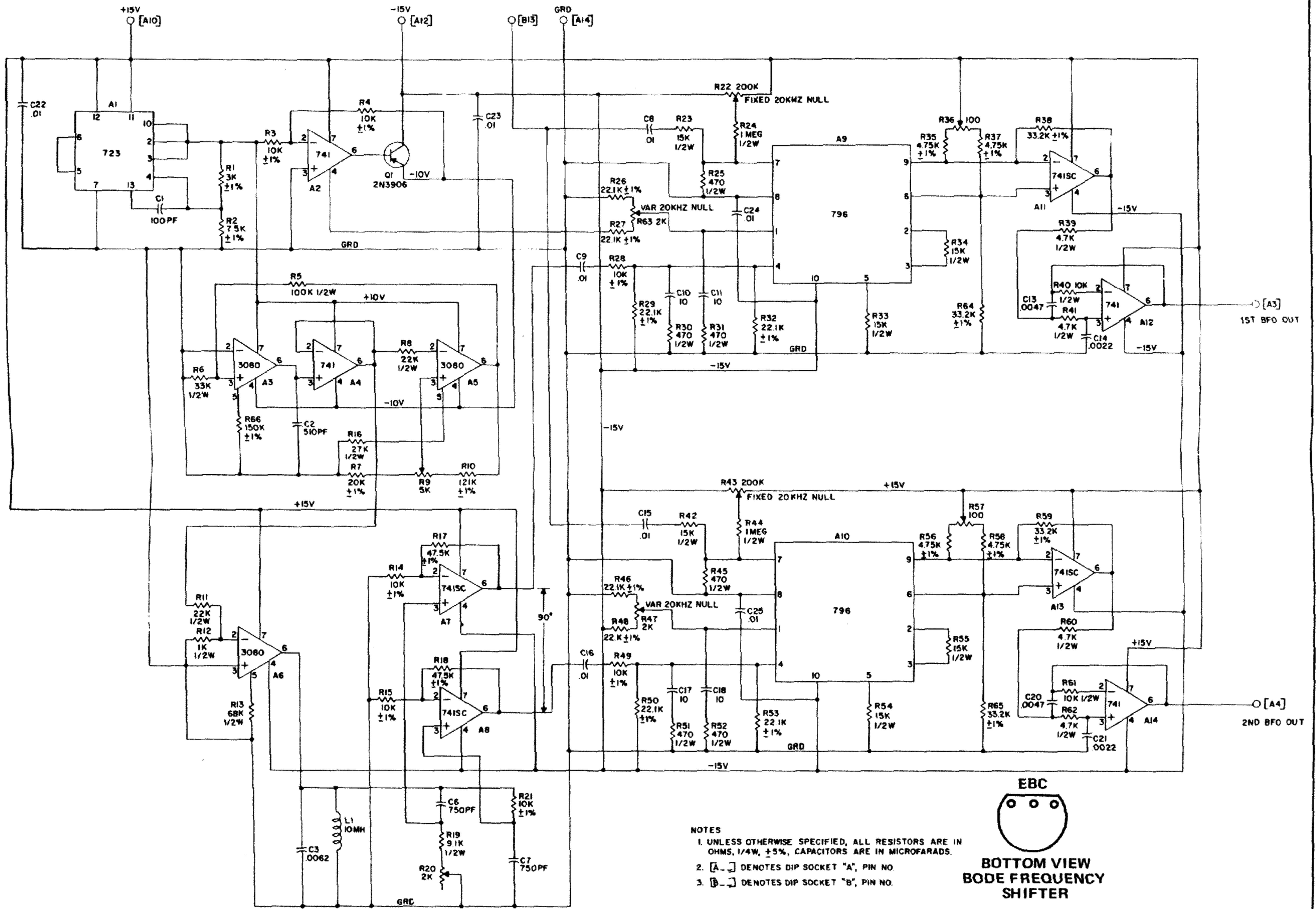

- NOTES
1. UNLESS OTHERWISE SPECIFIED, ALL RESISTORS ARE IN OHMS, 1/4W, ±5%, CAPACITORS ARE IN MICROFARADS.
  2. [A-] DENOTES DIP SOCKET "A", PIN NO.
  3. [B-] DENOTES DIP SOCKET "B", PIN NO.

EBC  
  
 BOTTOM VIEW  
 BODE FREQUENCY  
 SHIFTER

993-042655

FIGURE 41 FIXED OSCILLATOR (CARD NO. 3) - BODE FREQUENCY SHIFTER



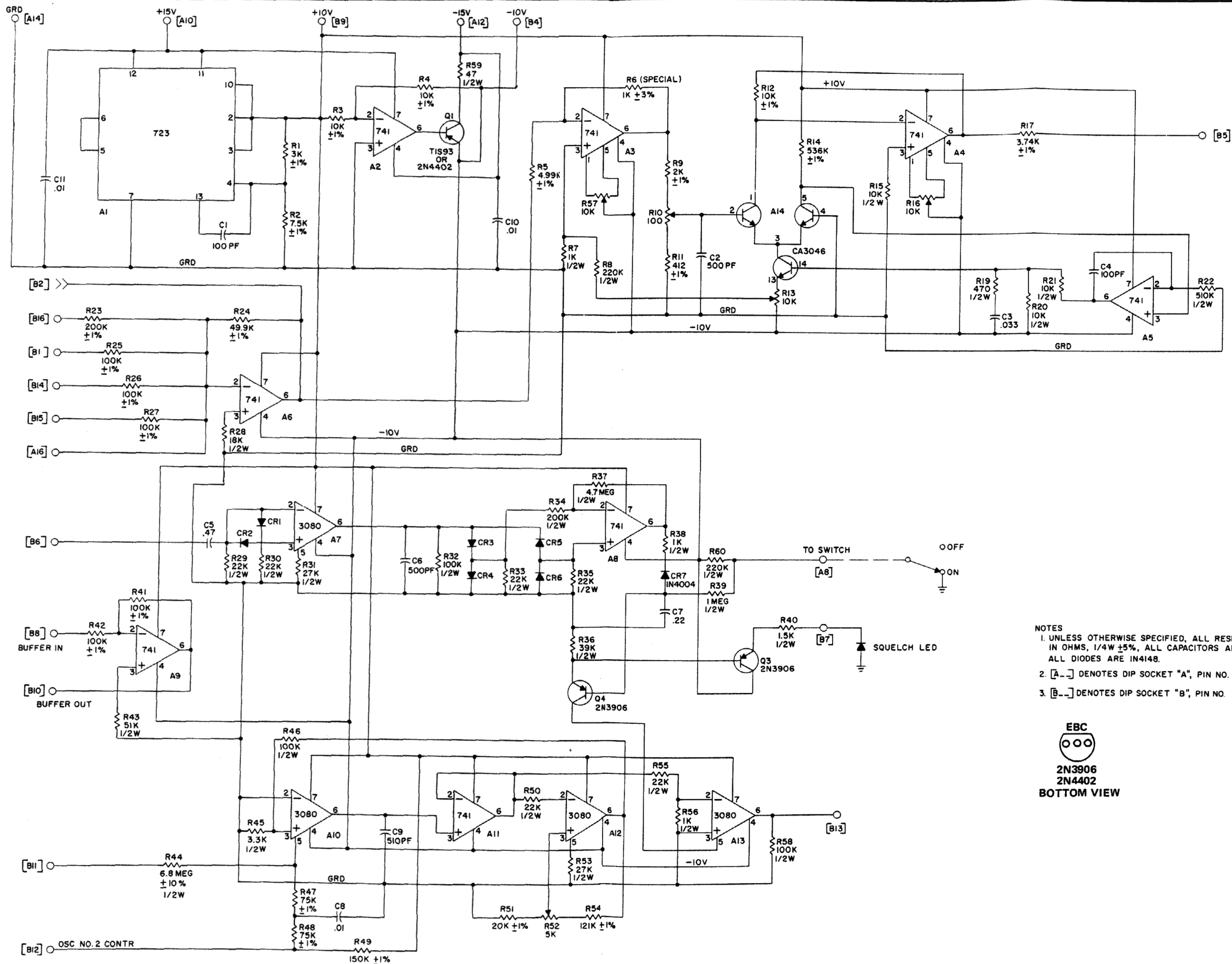

- NOTES
1. UNLESS OTHERWISE SPECIFIED, ALL RESISTORS ARE IN OHMS, 1/4W ±5%, ALL CAPACITORS ARE IN MICROFARADS, ALL DIODES ARE IN4148.
  2. [A-] DENOTES DIP SOCKET "A", PIN NO.
  3. [B-] DENOTES DIP SOCKET "B", PIN NO.

EBC  
  
 2N3906  
 2N4402  
 BOTTOM VIEW

FIGURE 10. VARIABLE OSCILLATOR (CARD NO. 9). CORE FREQUENCY QUANTIZER



**NOTES**

1. UNLESS OTHERWISE SPECIFIED, ALL RESISTORS ARE IN K-OHMS  $\pm 5\%$ , 1/4W, CAPACITORS ARE IN PICO FARADS  $\pm 5\%$ .
2. RESISTORS INDICATED BY \* ARE MATCHED PAIRS FOR 1% TRACKING.
3. [A-] DENOTES DIP SOCKET "A", PIN NO.

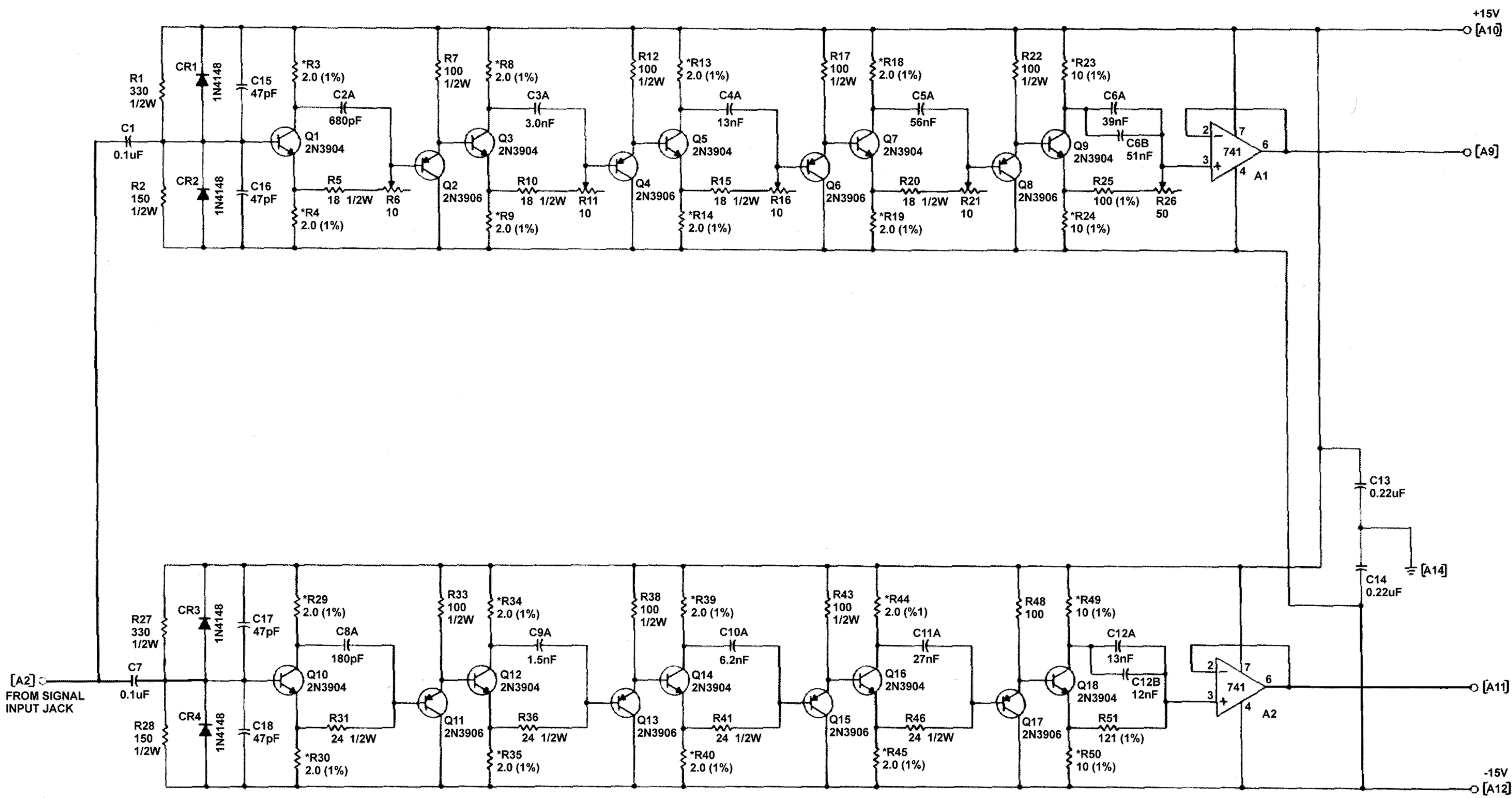
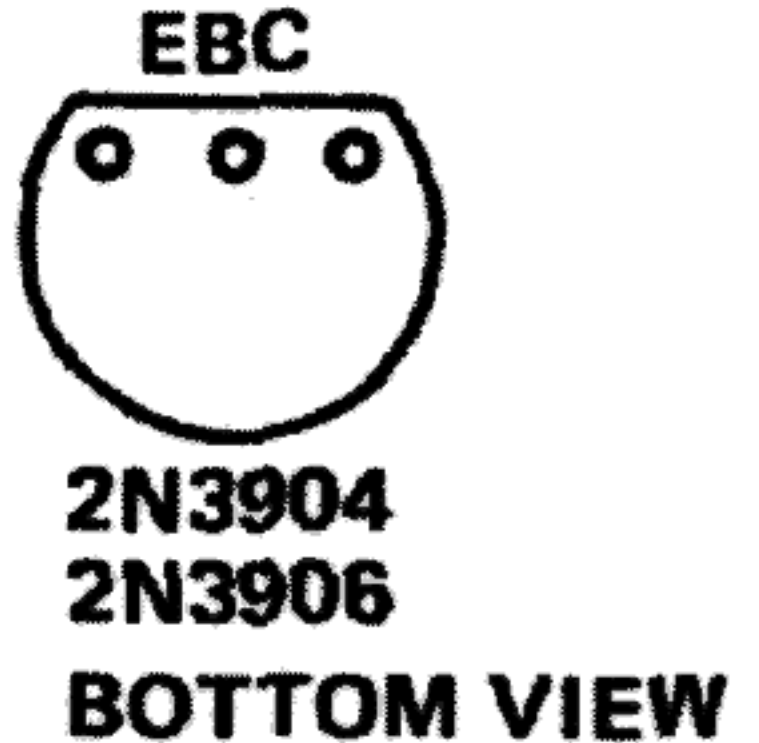
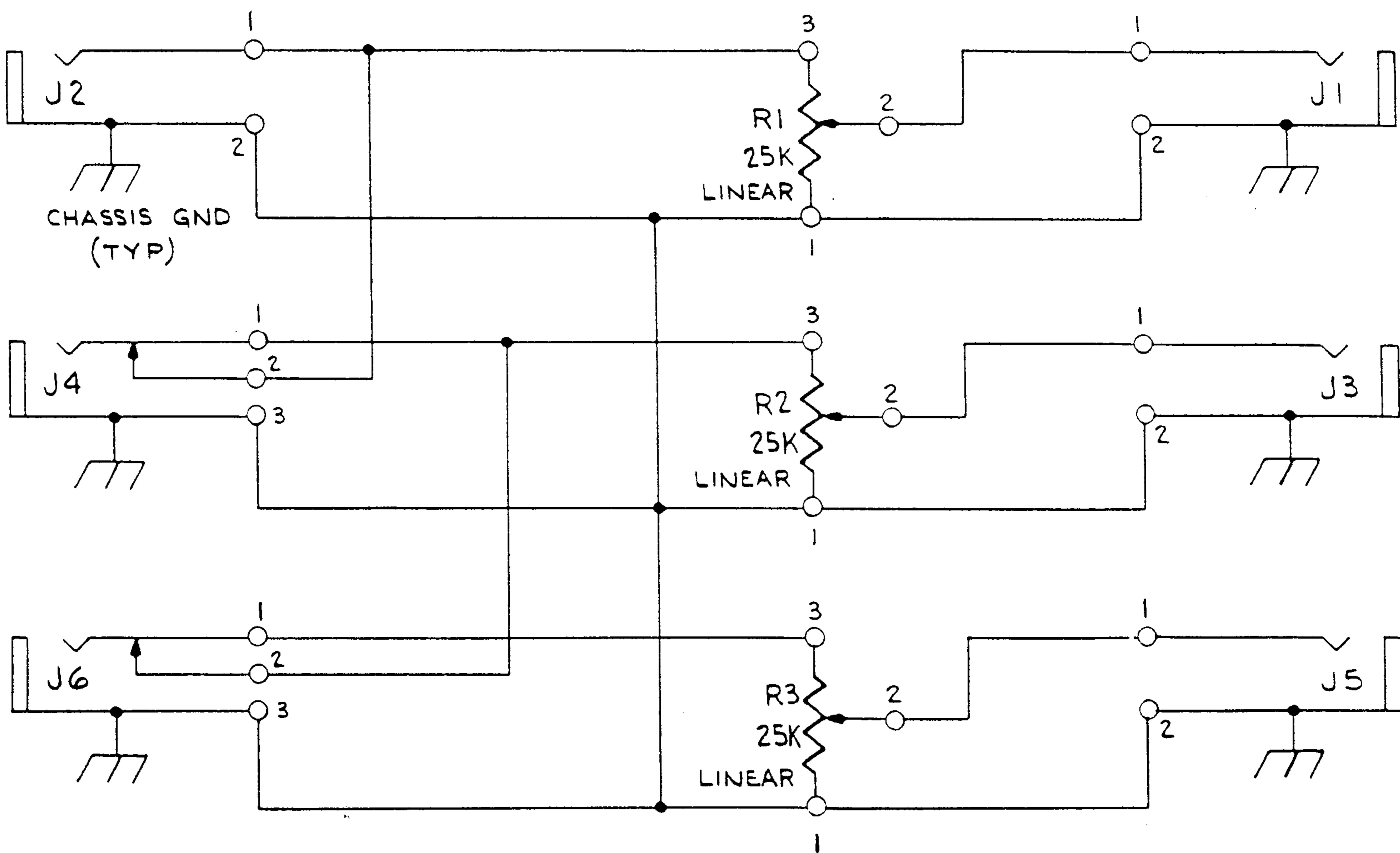
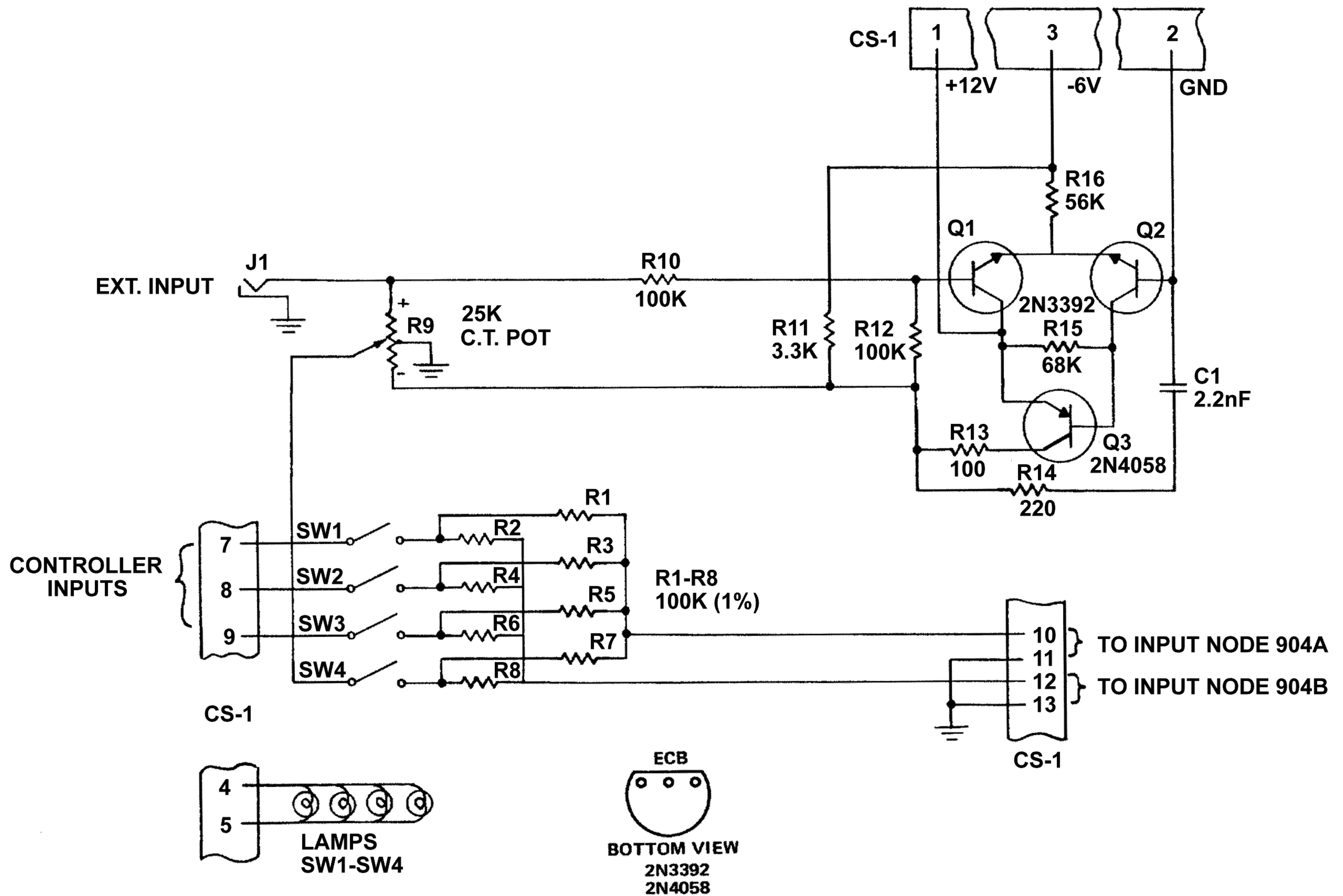

FIGURE 39 DOME FILTER (CARD NO. 1) - BODE FREQUENCY SHIFTER



MOOG MUSIC INC.  
 SCHEMATIC, ATTENUATORS MODULE 995  
 993-041812 08-024

FIGURE 38 ATTENUATORS MODEL 995



MOOG MUSIC INC.  
 SCHEMATIC, 904S CONTROL-992 MODULE  
 993-041804 1186

FIGURE 37 CONTROLLER MODEL 992 FOR MODEL 904S

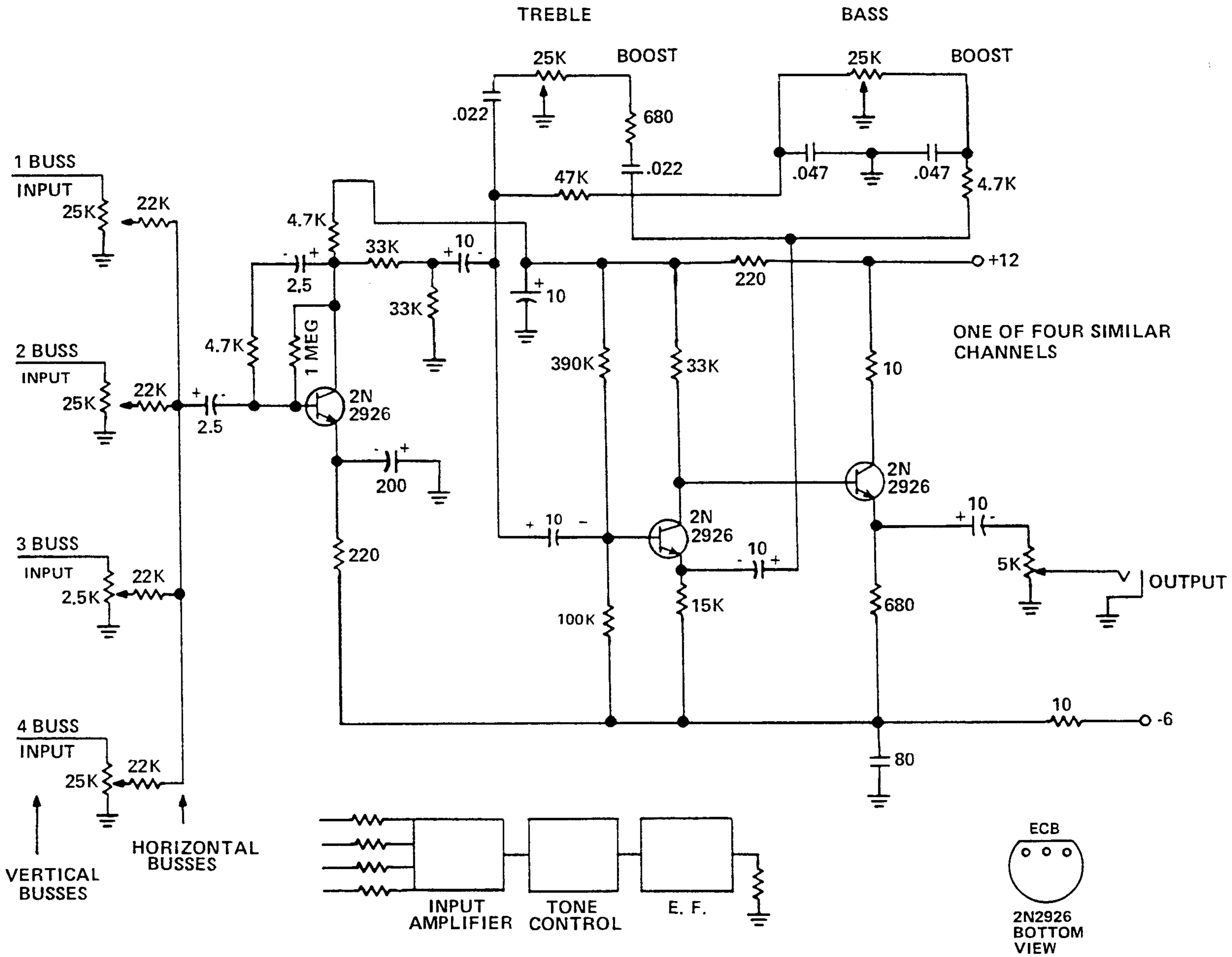
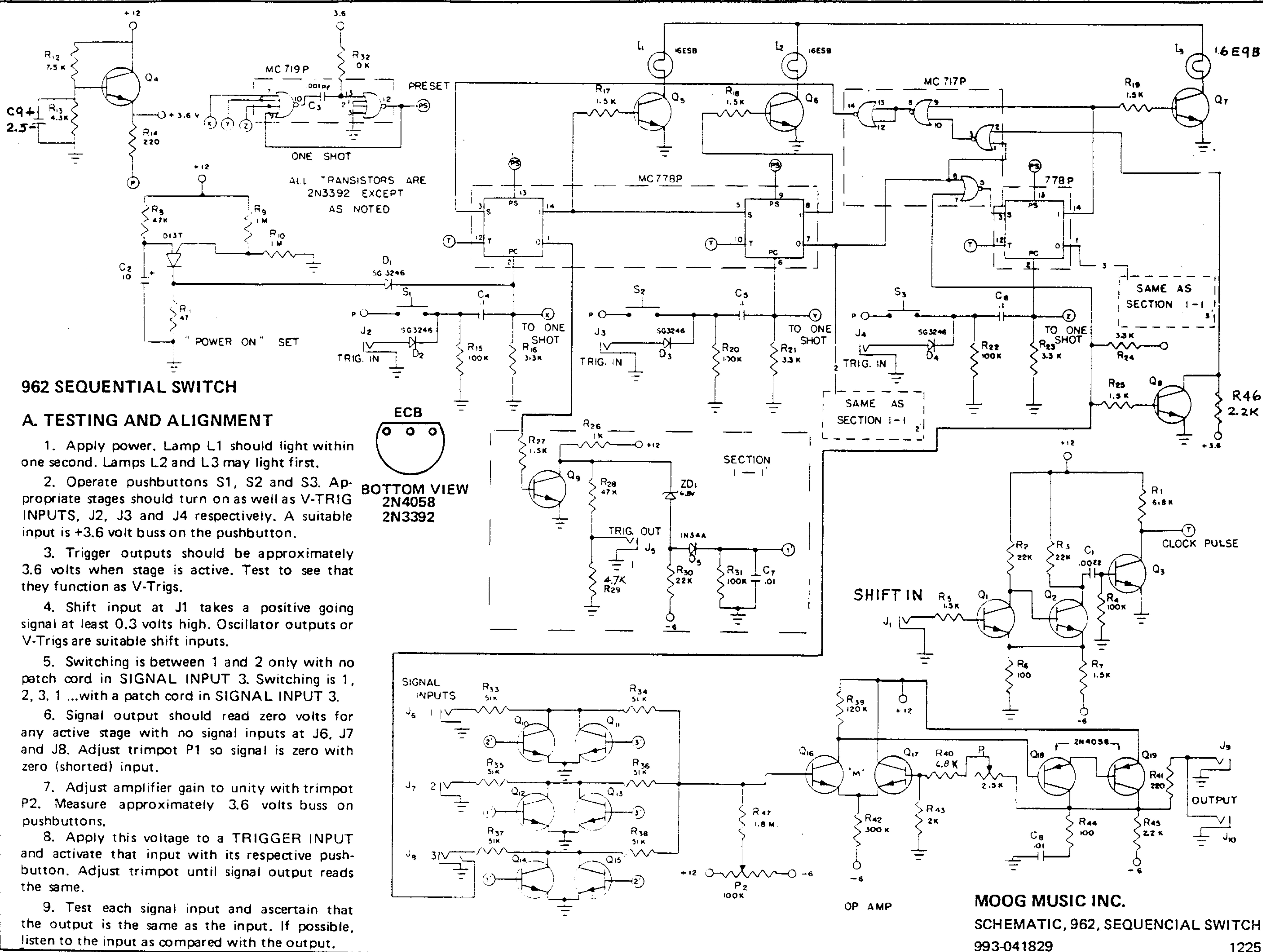
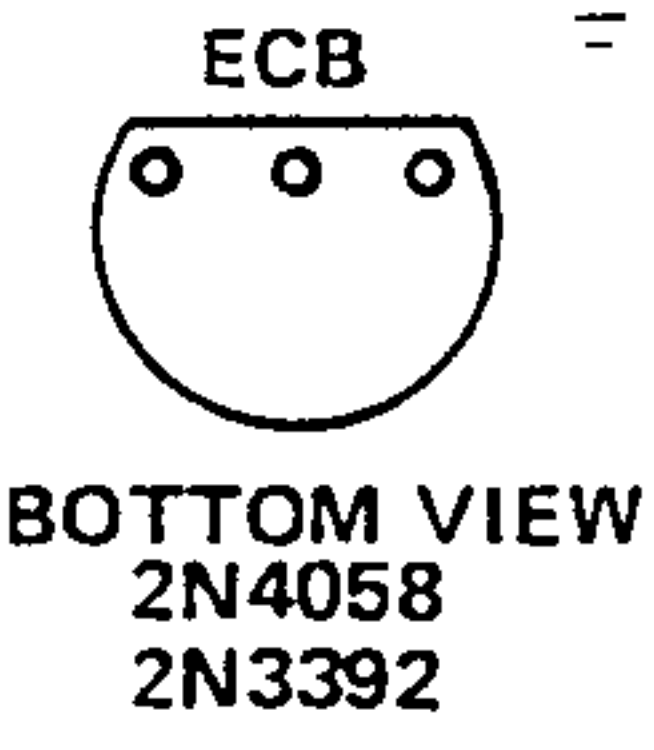

FIGURE 36 FOUR CHANNEL MIXER MODEL 984



**962 SEQUENTIAL SWITCH**  
**A. TESTING AND ALIGNMENT**

1. Apply power. Lamp L1 should light within one second. Lamps L2 and L3 may light first.
2. Operate pushbuttons S1, S2 and S3. Appropriate stages should turn on as well as V-TRIG INPUTS, J2, J3 and J4 respectively. A suitable input is +3.6 volt buss on the pushbutton.
3. Trigger outputs should be approximately 3.6 volts when stage is active. Test to see that they function as V-Trigs.
4. Shift input at J1 takes a positive going signal at least 0.3 volts high. Oscillator outputs or V-Trigs are suitable shift inputs.
5. Switching is between 1 and 2 only with no patch cord in SIGNAL INPUT 3. Switching is 1, 2, 3, 1 ...with a patch cord in SIGNAL INPUT 3.
6. Signal output should read zero volts for any active stage with no signal inputs at J6, J7 and J8. Adjust trimpot P1 so signal is zero with zero (shorted) input.
7. Adjust amplifier gain to unity with trimpot P2. Measure approximately 3.6 volts buss on pushbuttons.
8. Apply this voltage to a TRIGGER INPUT and activate that input with its respective push-button. Adjust trimpot until signal output reads the same.
9. Test each signal input and ascertain that the output is the same as the input. If possible, listen to the input as compared with the output.



MOOG MUSIC INC.  
 SCHEMATIC, 962, SEQUENTIAL SWITCH  
 993-041829 1225

FIGURE 35. SEQUENTIAL SWITCH MODEL 962

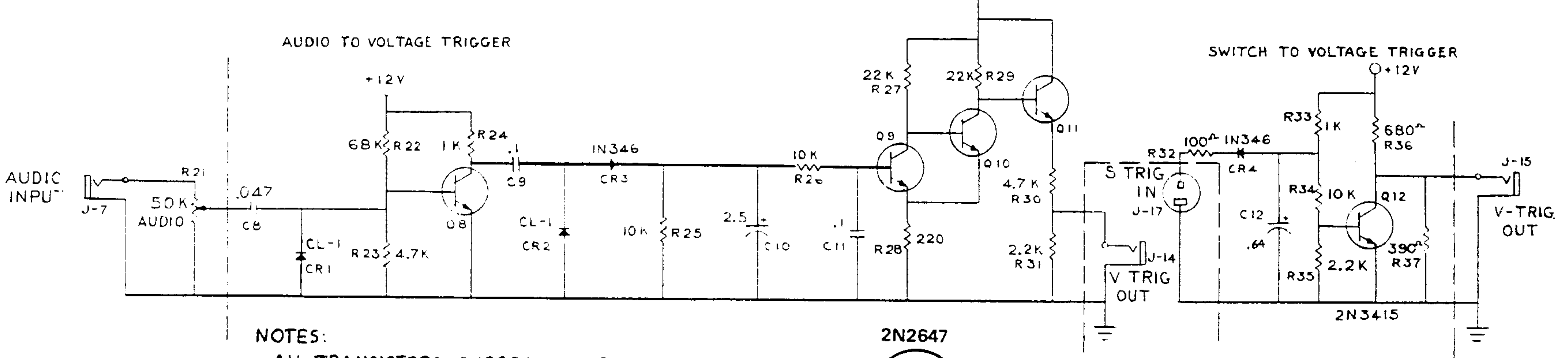
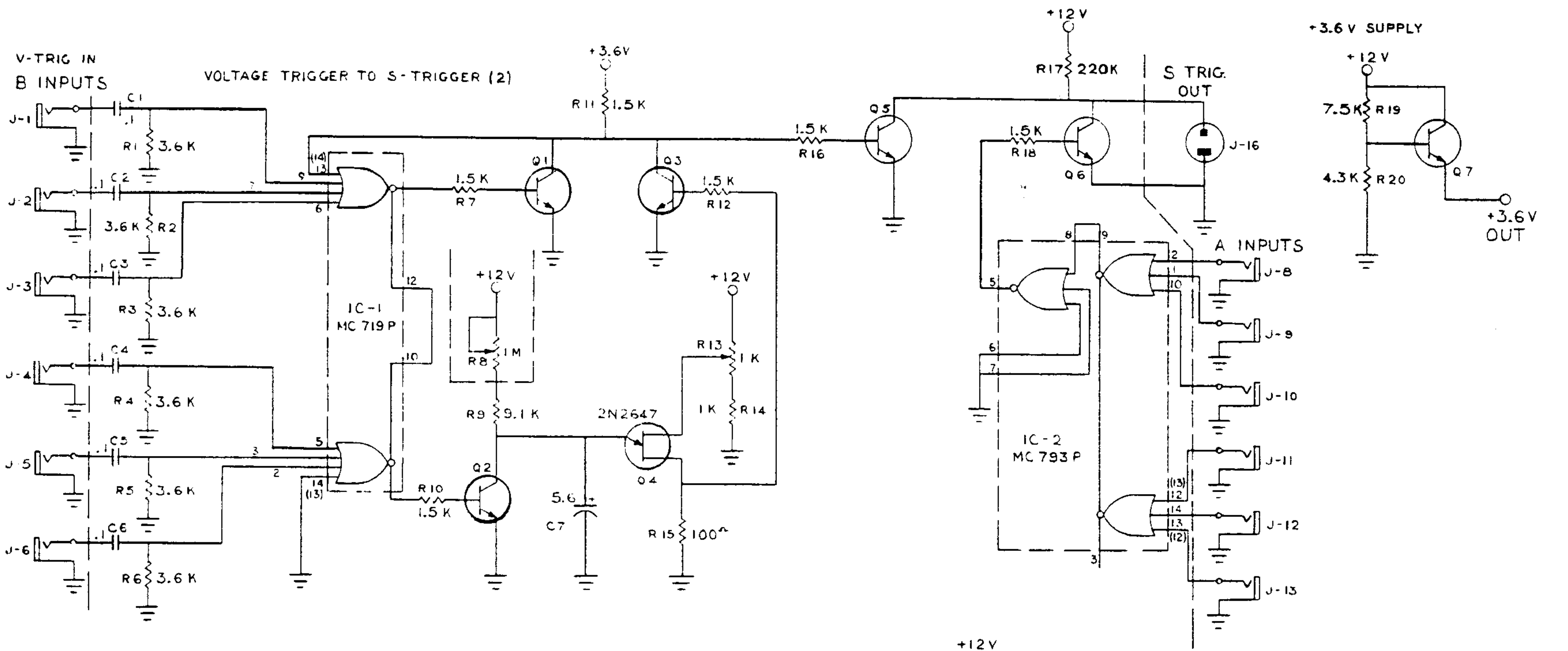

NOTES:  
ALL TRANSISTORS 2N3392 EXCEPT WHERE NOTED.

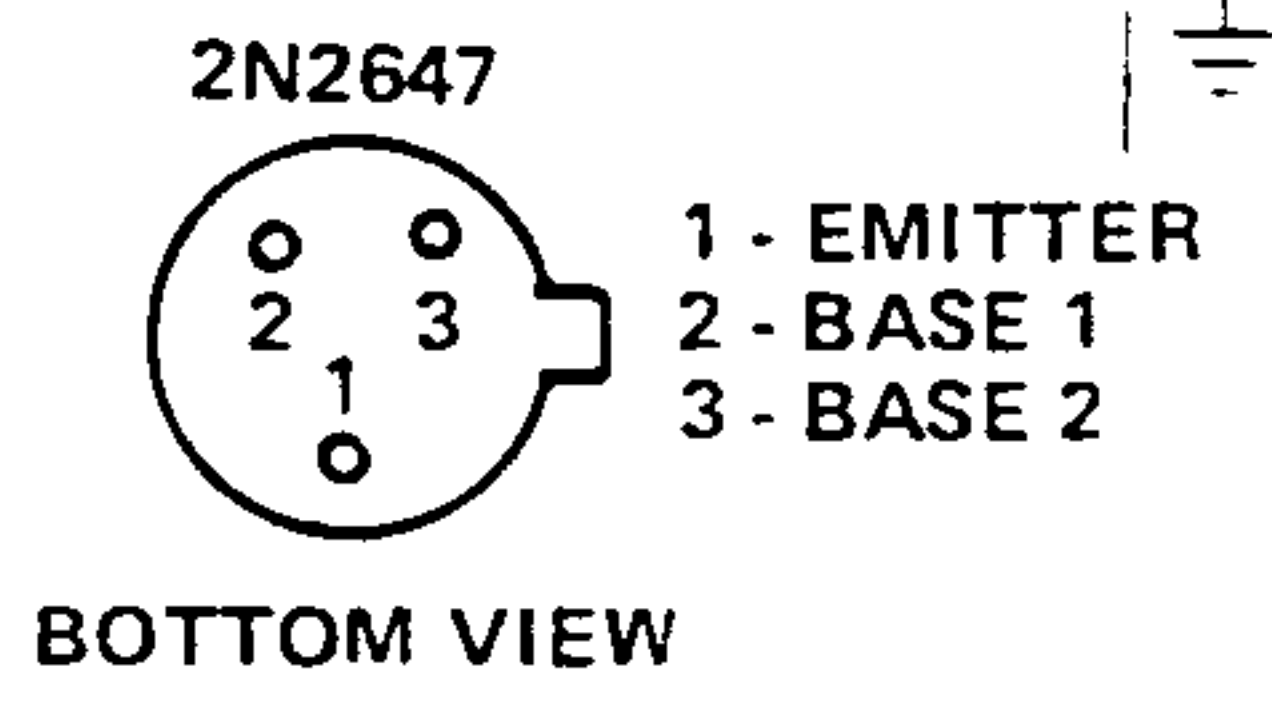
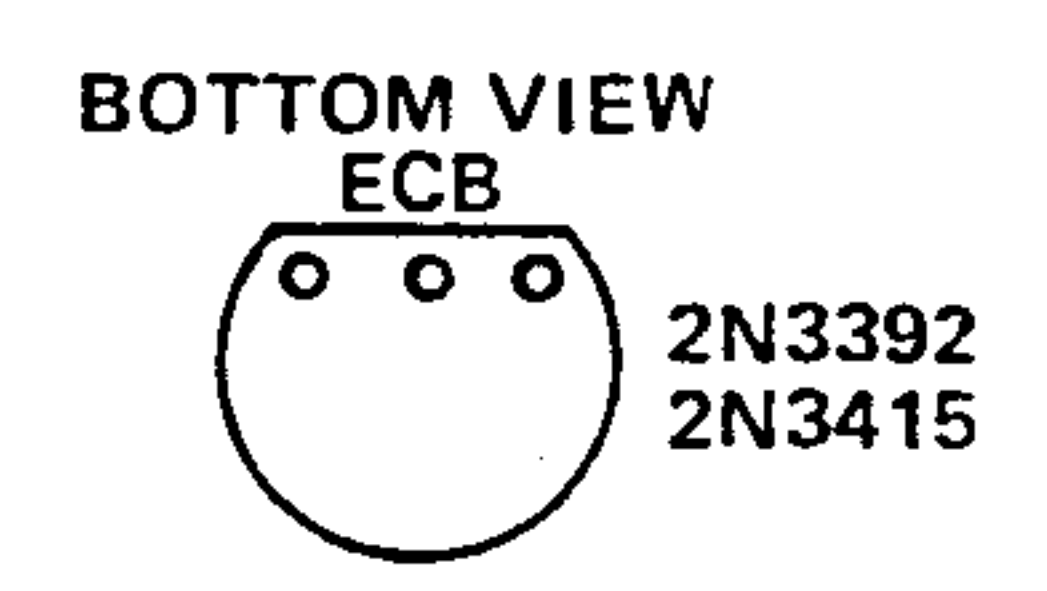

MOOG MUSIC INC.  
SCHEMATIC, 961, INTERFACE  
993-041827 1212

FIGURE 34 INTERFACE MODEL 961

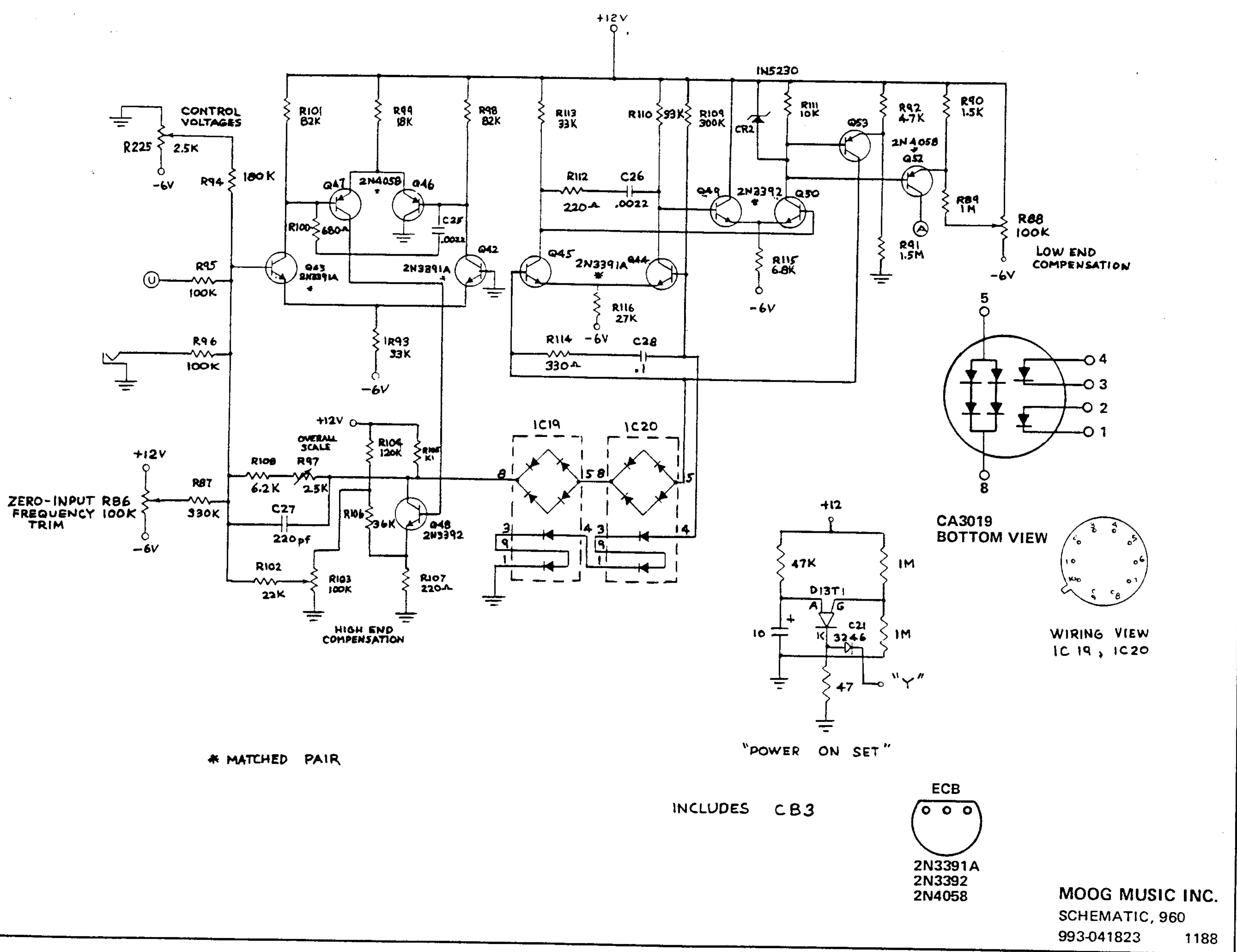
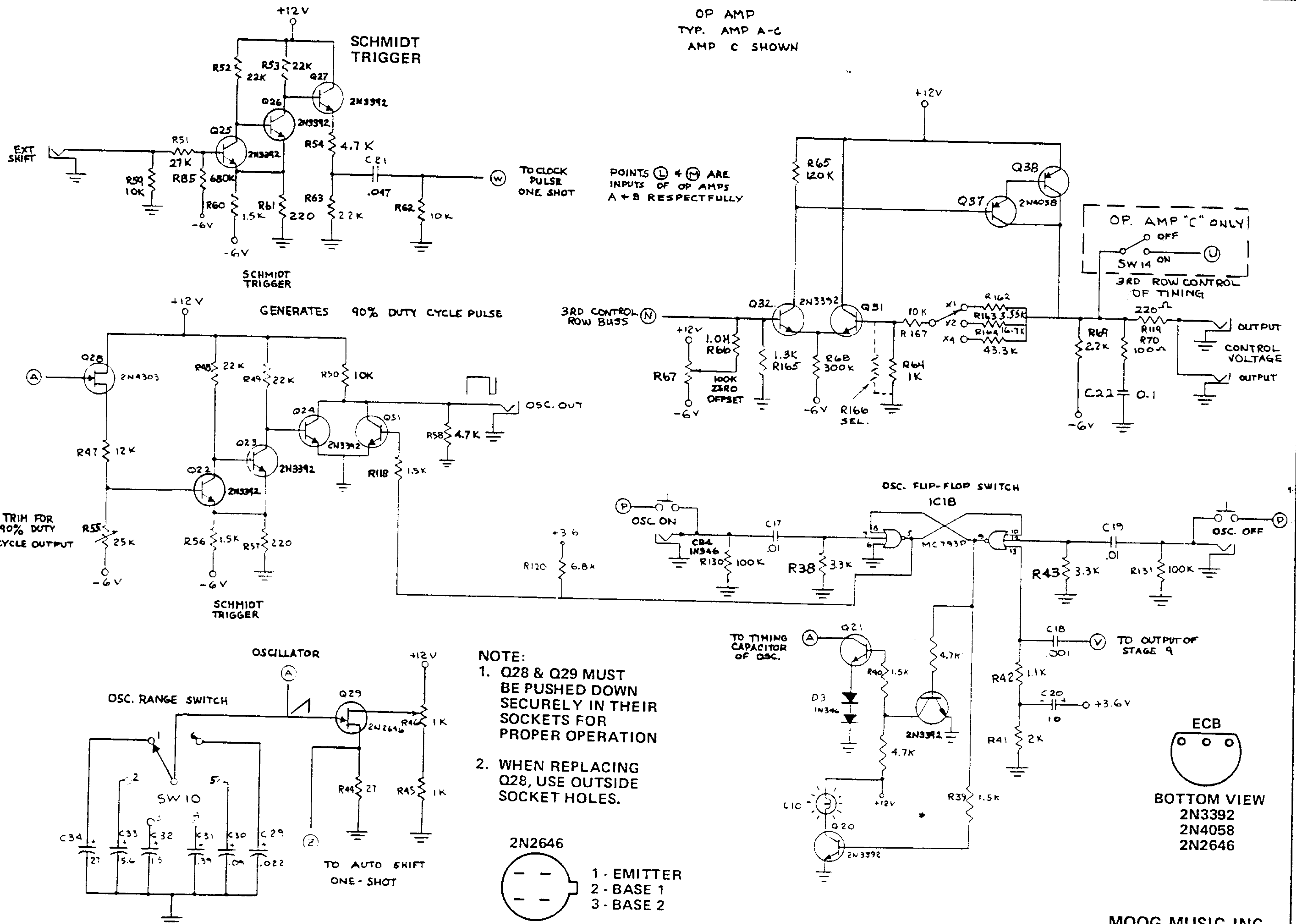
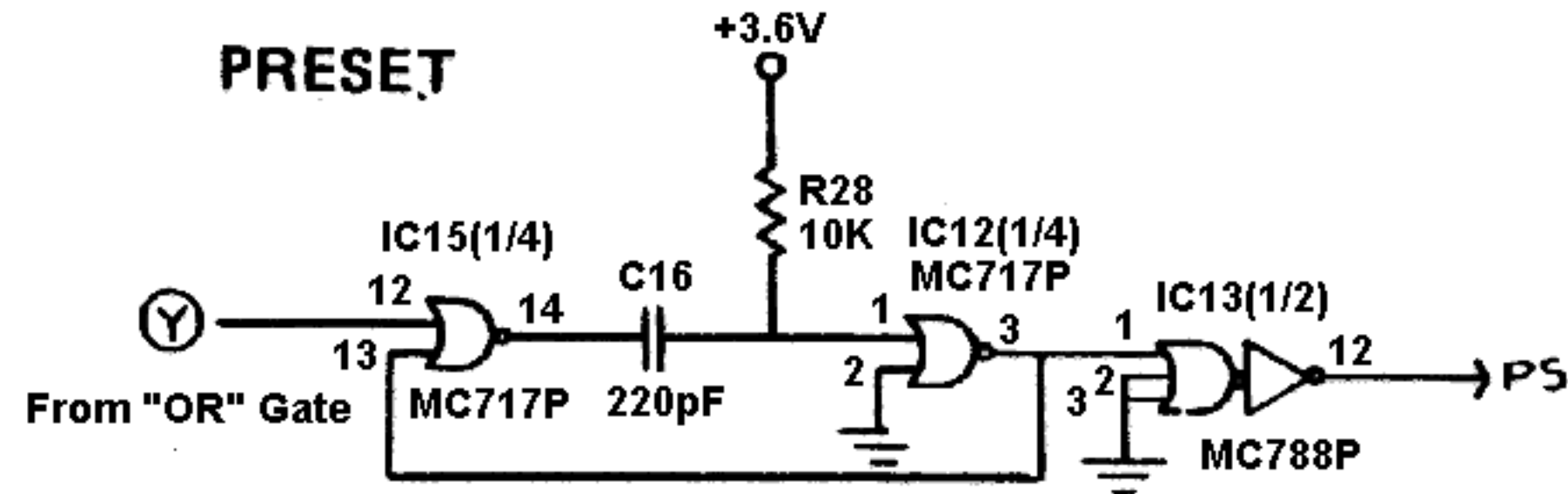
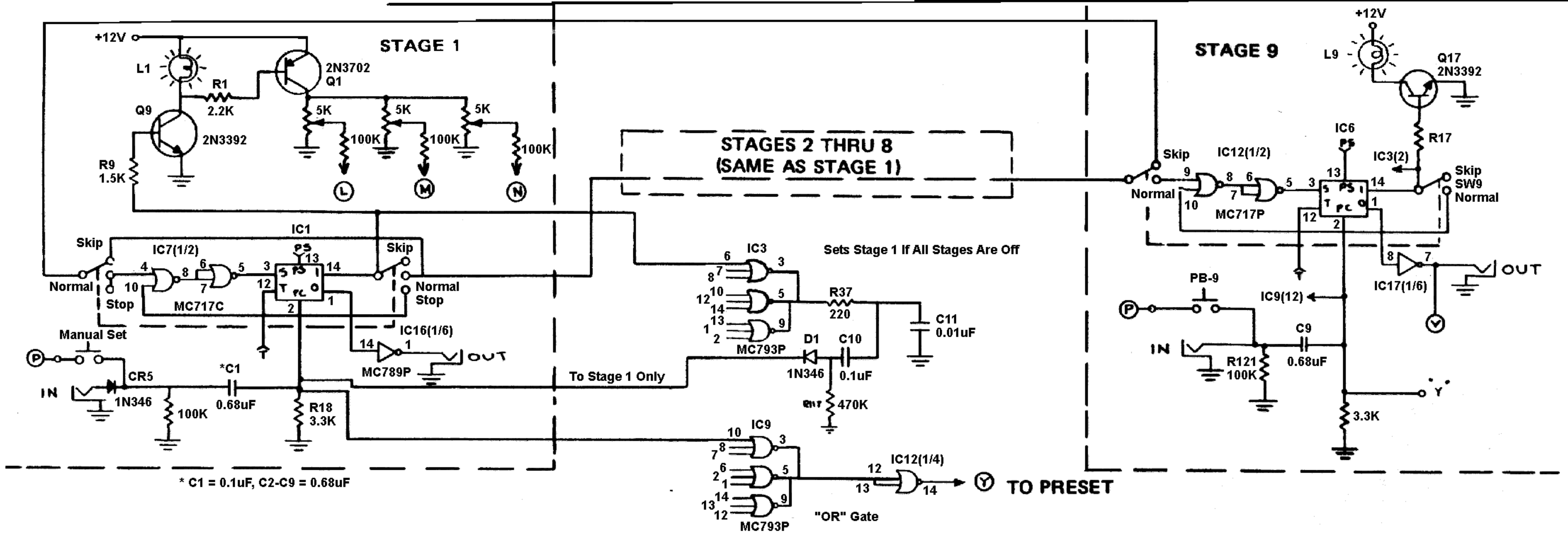

FIGURE 33. SEQUENTIAL CONTROLLER (CIRCUIT BOARD 3) MODEL 960



# FIG 32 SEQUENTIAL CONTROLLER (CIRCUIT BOARD 2) MODEL 960





**CLEARS ENTIRE SHIFT REGISTER IN THE PROCESS OF TURNING ON A COLUMN. (EXCLUDING SHIFTING)**

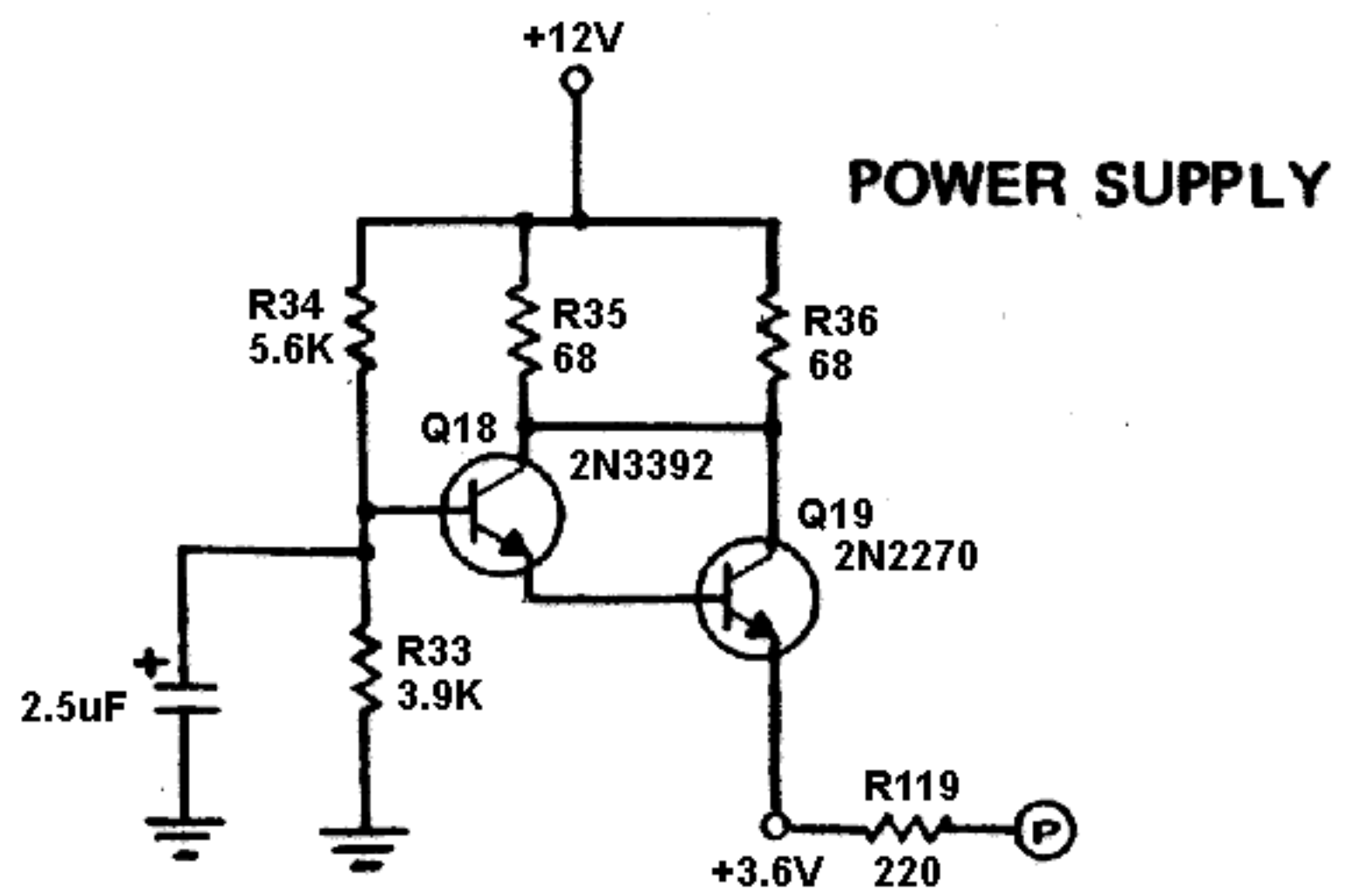
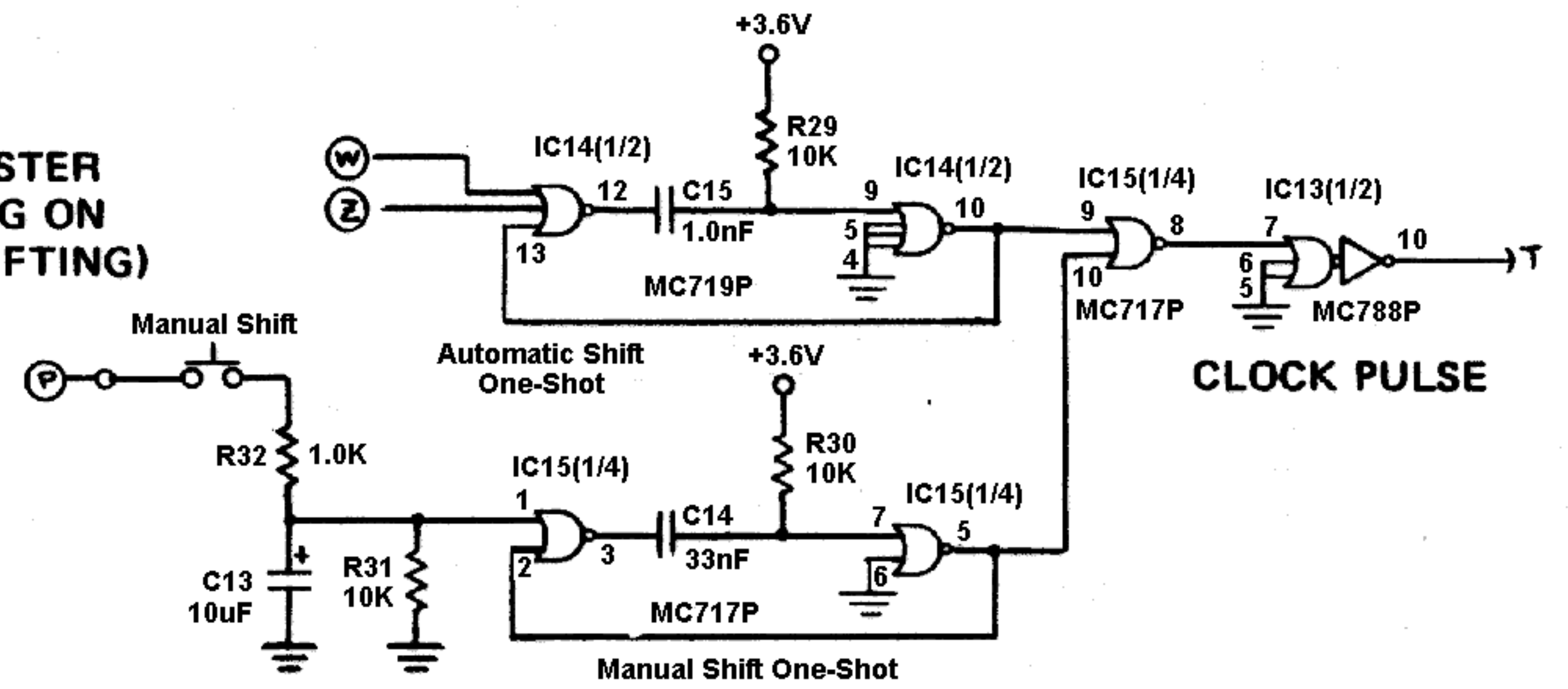

- NOTE:**
- INTERMITTENT OPERATION MAY BE DUE TO SHORTING MOLEX CONNECTORS OR CORROSION**
  - WHEN REPLACING SOCKETED IC'S, SOLDER FOUR CORNERS TO SOCKET**

**INCLUDES CB-1**

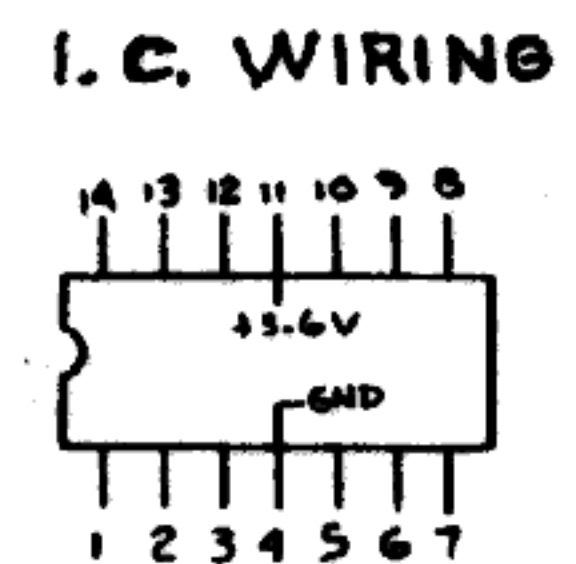

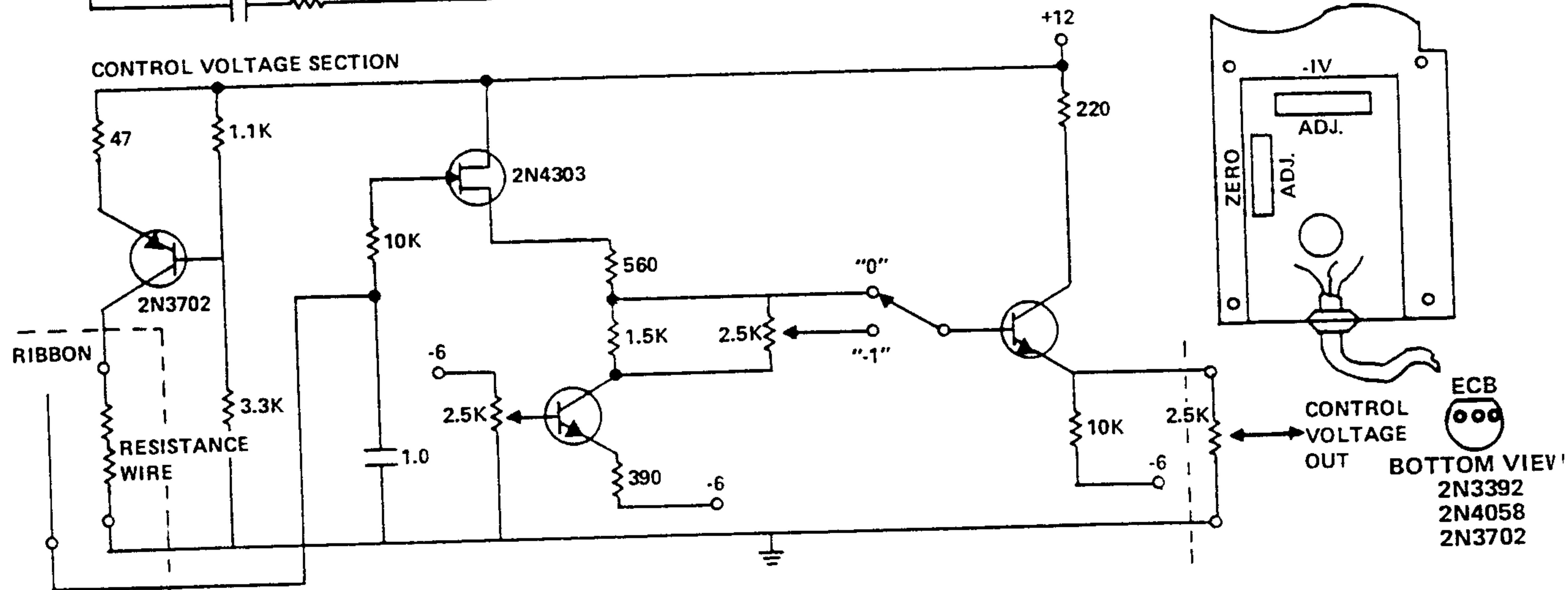
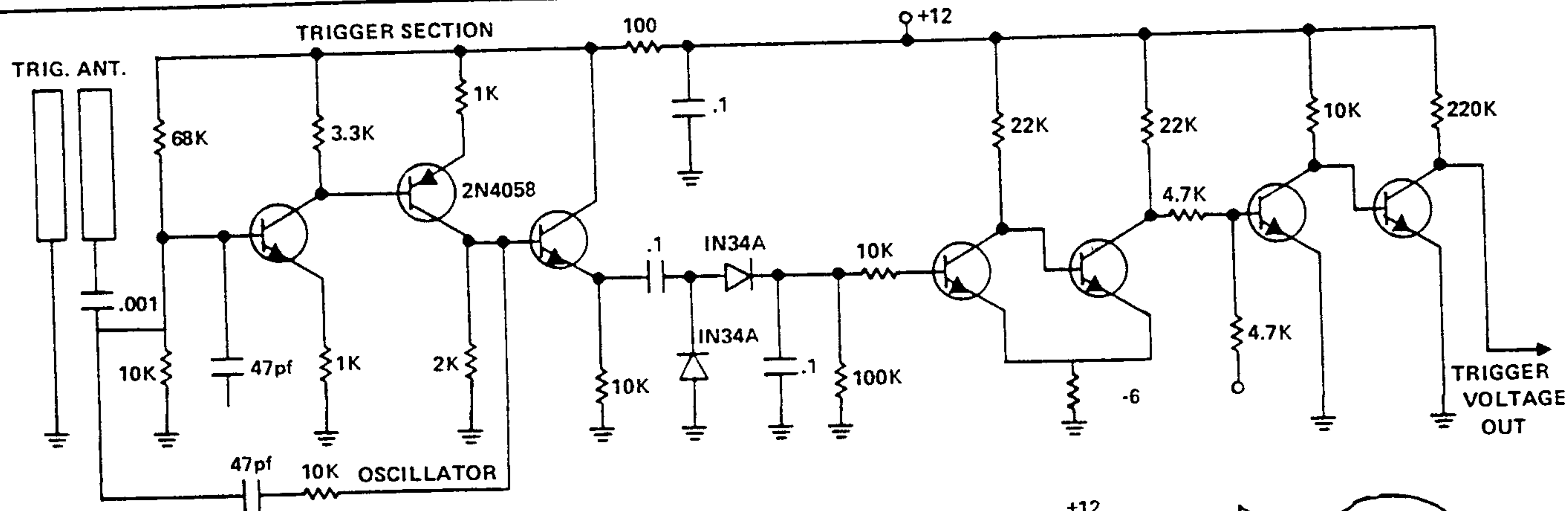

NOTE: ALL UNLABELED TRANSISTORS OF TYPE 2N3392

## 956 RIBBON CONTROLLER TEST PROCEDURE

1. Connect the 956 Ribbon Controller to the test rack.
2. Patch TRIGGER output of the 956 to the 911 Envelope Generator, then to the 902 Voltage Controlled Amplifier. Connect SIGNAL OUTPUT of a voltage controlled oscillator to the 902 SIGNAL INPUT. Connect 902 SIGNAL OUTPUT to a monitor amplifier and speaker.
3. Connect PITCH output to the voltage controlled oscillator CONTROL INPUT.
4. Touch TRIGGER bar on the 956. Oscillator should be heard. Adjust the 911 and 902 for a square envelope.
5. Set SCALE to "1" and LOW END VOLTAGE to "0".
6. Slide finger up and down the ribbon while touching the TRIGGER bar. A pitch change should be heard.
7. Adjust the ZERO ADJ. trimpot for 0.0 volt dc indication at PITCH OUTPUT jack.
8. Adjust the -1V. ADJ. trimpot for a 1.0 dc indication when switching between 0 and -1 low end voltage. Trimpot offsets - 1 volt position only.
9. Play the ribbon. It should have a 6.0 volt dc span (six octaves). Decrease the SCALE setting to "5". The ribbon should now span 3.0 volts (three octaves).
10. Slowly play the ribbon listening for erratic pitch changes. If erratic conditions exist, lightly sand the resistance wire and underside of ribbon with No. 400 emery paper. Apply a light film of camolin to the resistance wire and ribbon to further promote a smooth contact.
11. Depress and release ribbon at low, middle and high end with scale at "10". Check for drift of the sample hold circuit at each of these points. Drift shall be less than 10 mv/minute as measured at the PITCH CONTROL OUTPUT jack.

993-042651

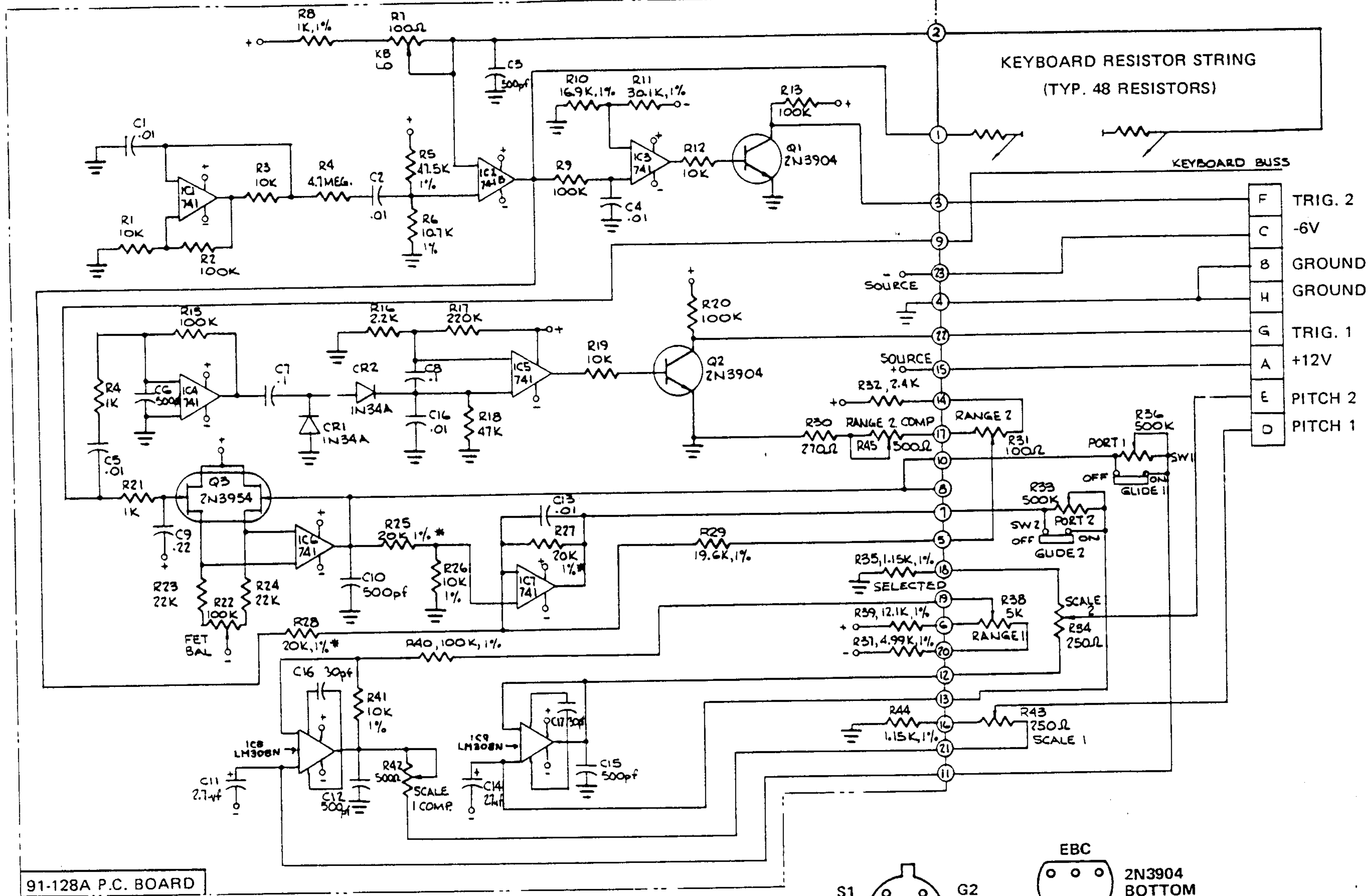

91-128A P.C. BOARD

NOTE:  
1. \* MATCHED TO 0.1%.

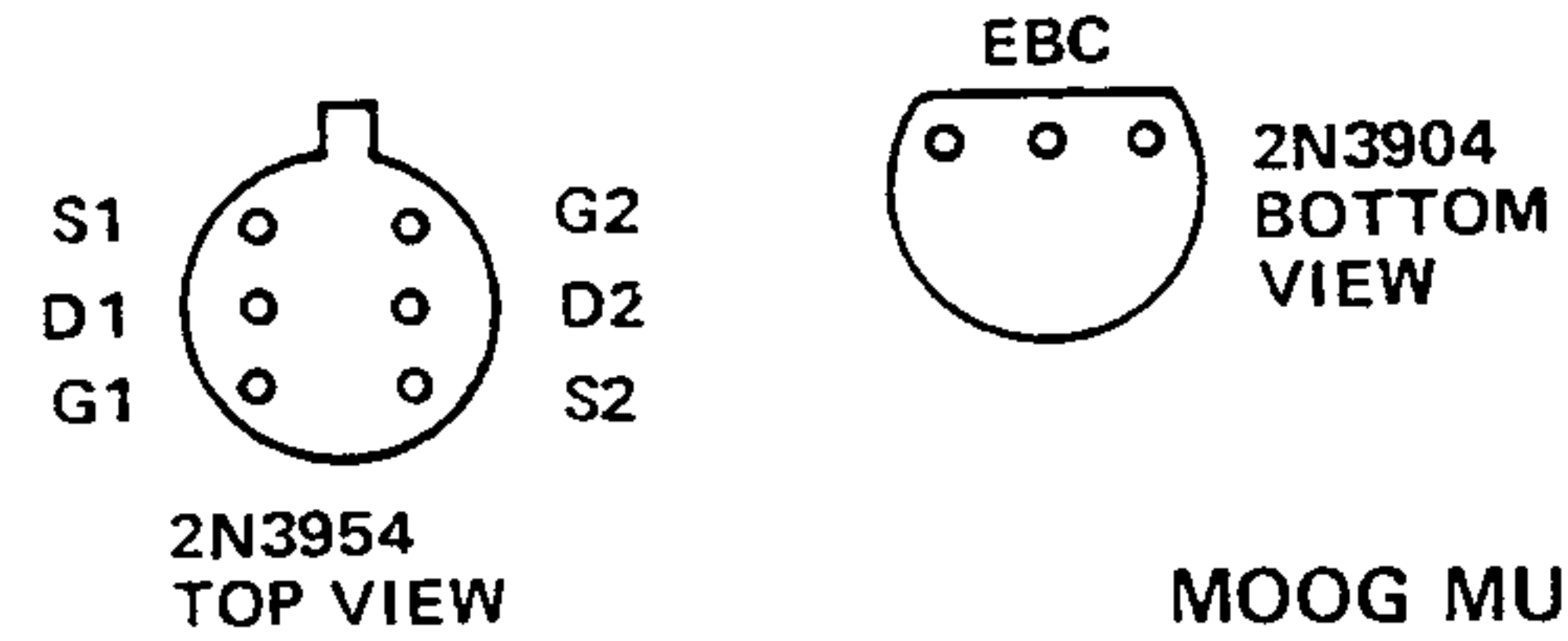
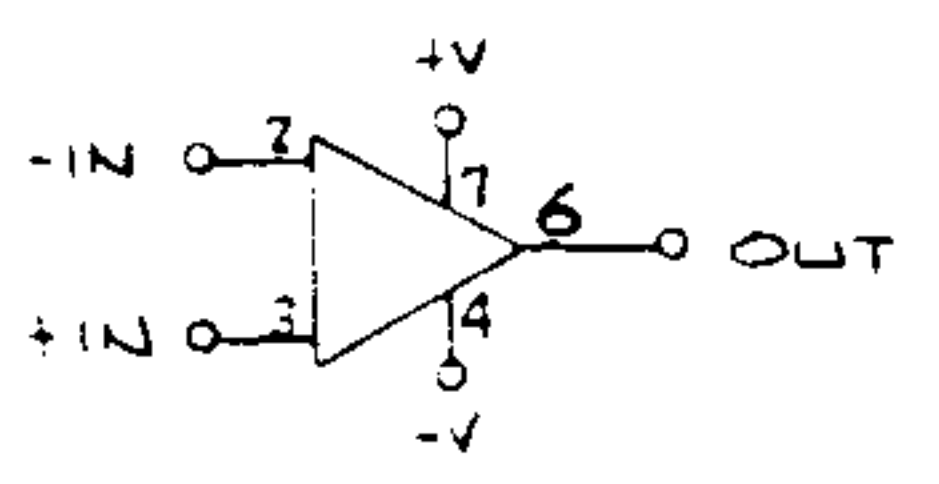

MOOG MUSIC INC.  
SCHEMATIC, 2 NOTE KEYBOARD  
952 993-041832 08-008

FIGURE 29 TWO NOTE KEYBOARD MODEL 952

MODEL 952 TWO NOTE KEYBOARD TEST PROCEDURE  
(SEE PAGE 34 FOR SCHEMATIC DIAGRAM)

NOTE

The 952 Two Note Keyboard must be connected to a tested professional system.

1. Set front panel RANGE and SCALE controls at "5"; set PORTAMENTO controls at "0".
2. KB HI voltage should be approximately +2.2 volts dc.
3. Adjust (KB LO) pot R7 for KB LO indication of the same potential as in step 1 but of the opposite polarity.
4. Connect voltmeter from KB BUSS to KB GUARD. Adjust (FET BAL) pot R22 for no voltage while alternately depressing HI and LO "C" keys.
5. Set all front panel controls at "5". Turn both GLIDE switches to OFF.
6. Connect voltmeter to PITCH 1 output. Depress middle "C" key and adjust RANGE 1 for 0 volts dc. RANGE 1 pointer shall be within one small division of "5".
7. Depress HI "C" key and adjust (SCALE 1 COMP) R42 for +2.0 volts. Depress LO "C" key and observe -2.0 volts  $\pm$  2 mv.
8. Connect voltmeter to PITCH 2 output. Set all front panel controls at "5". Depress middle "C" key and adjust (RANGE 2 COMP) R45 for 0 volts dc.
9. Depress HI "C" key and adjust SCALE 2 for +2.0 volts dc. SCALE 2 pointer shall be within one small division of "5".
10. Depress LO "C" key and observe -2.0 volts dc  $\pm$  2 mv.
11. Connect voltmeter high side to PITCH 1 output; connect low side to PITCH 2 output. Check several points (keys) on keyboard. At no check, shall the voltmeter indication exceed 1 mv.
12. Connect voltmeter to TRIG. 1 output. Observe indication of approximately +12 volts dc.
13. Depress any key. Output should drop to near 0 volts dc.
14. Connect voltmeter to TRIG. 2 output. Observe indication of approximately +12 volts dc.
15. Depress any key and observe that no change should occur.
16. Depress two keys and observe that output should drop to near 0 volts dc.
17. Check both GLIDE 1 and 2 with PORTAMENTO 1 and 2 controls set at 10. GLIDE should take approximately 10 seconds.
18. Check PITCH contacts by listening to an oscillator that the 952 Two Note Keyboard is driving.
19. Check trigger contacts by tapping keys and listening for contact bounce or double triggering.

952 ADJUSTMENT LOCATIONS

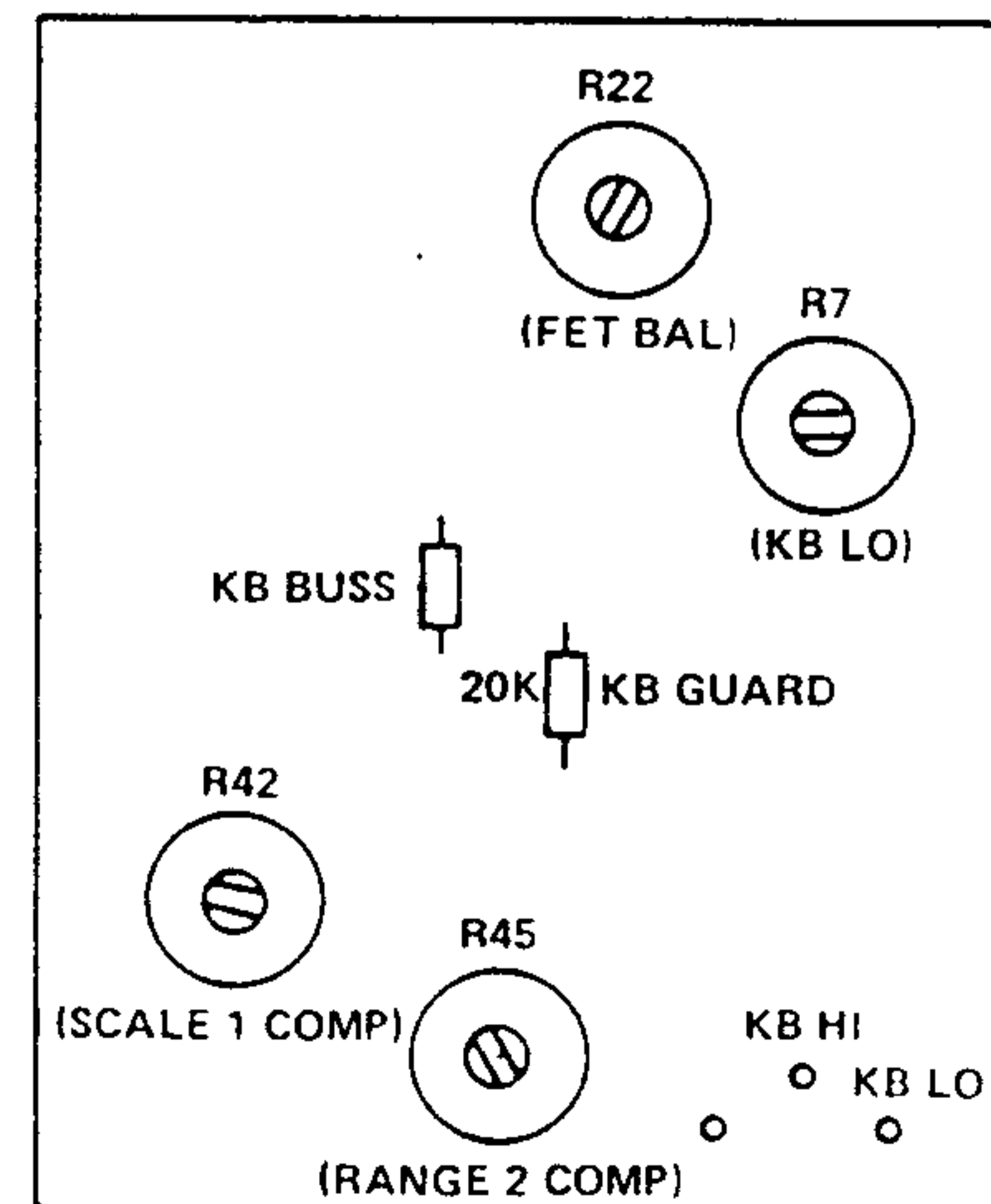

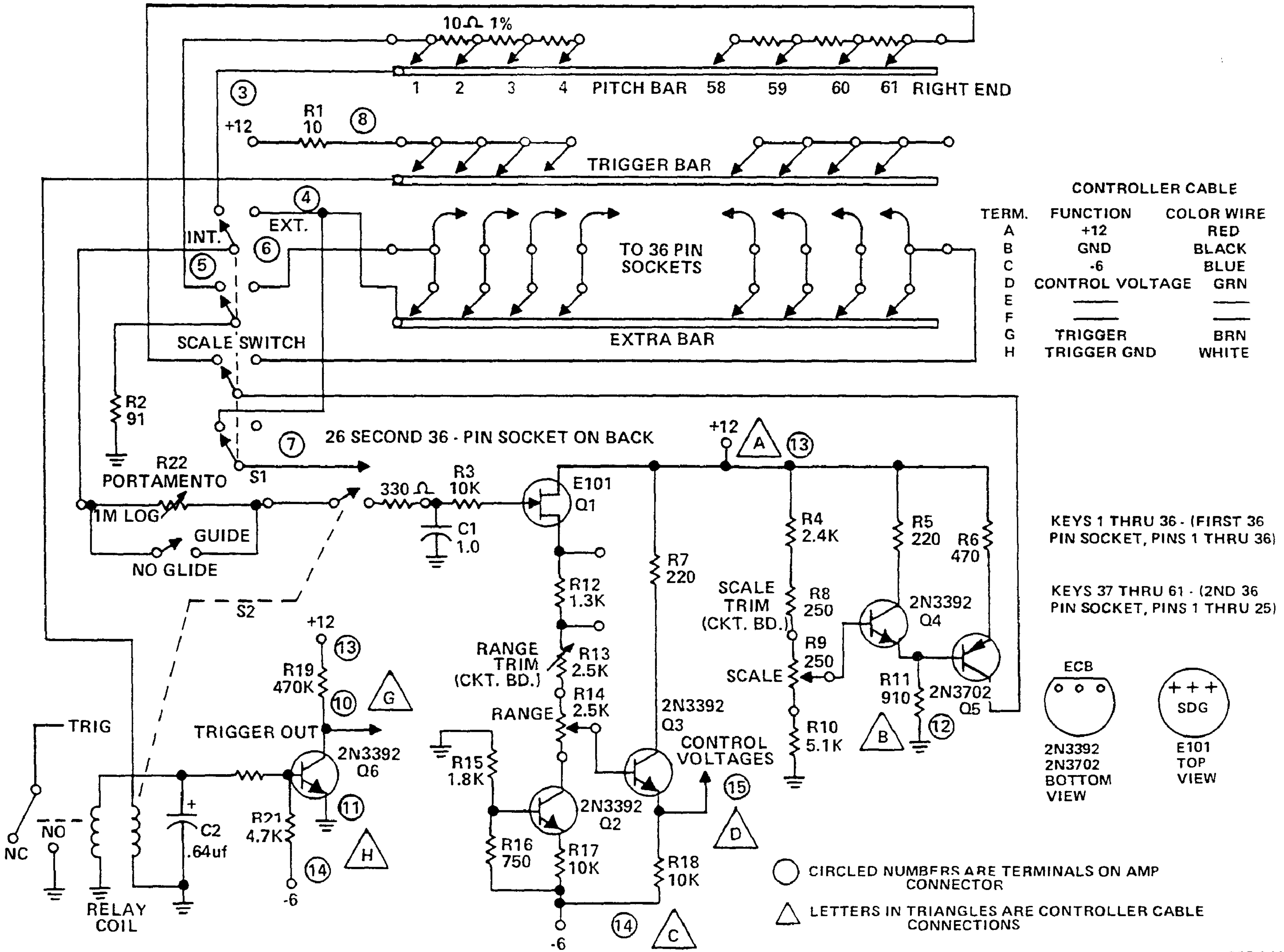

FIGURE 26 KEYBOARD MODEL 950

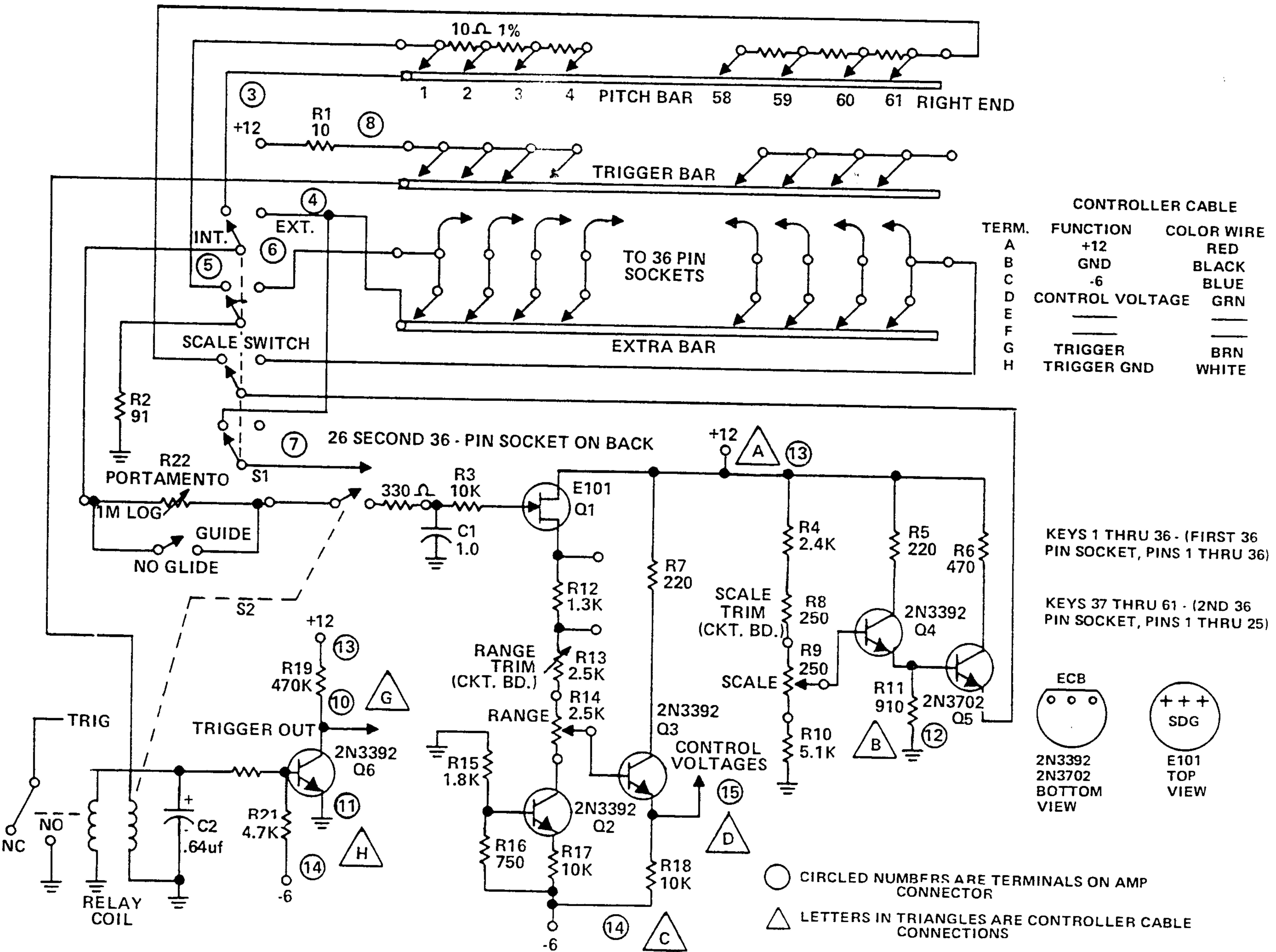

FIGURE 26 KEYBOARD MODEL 950

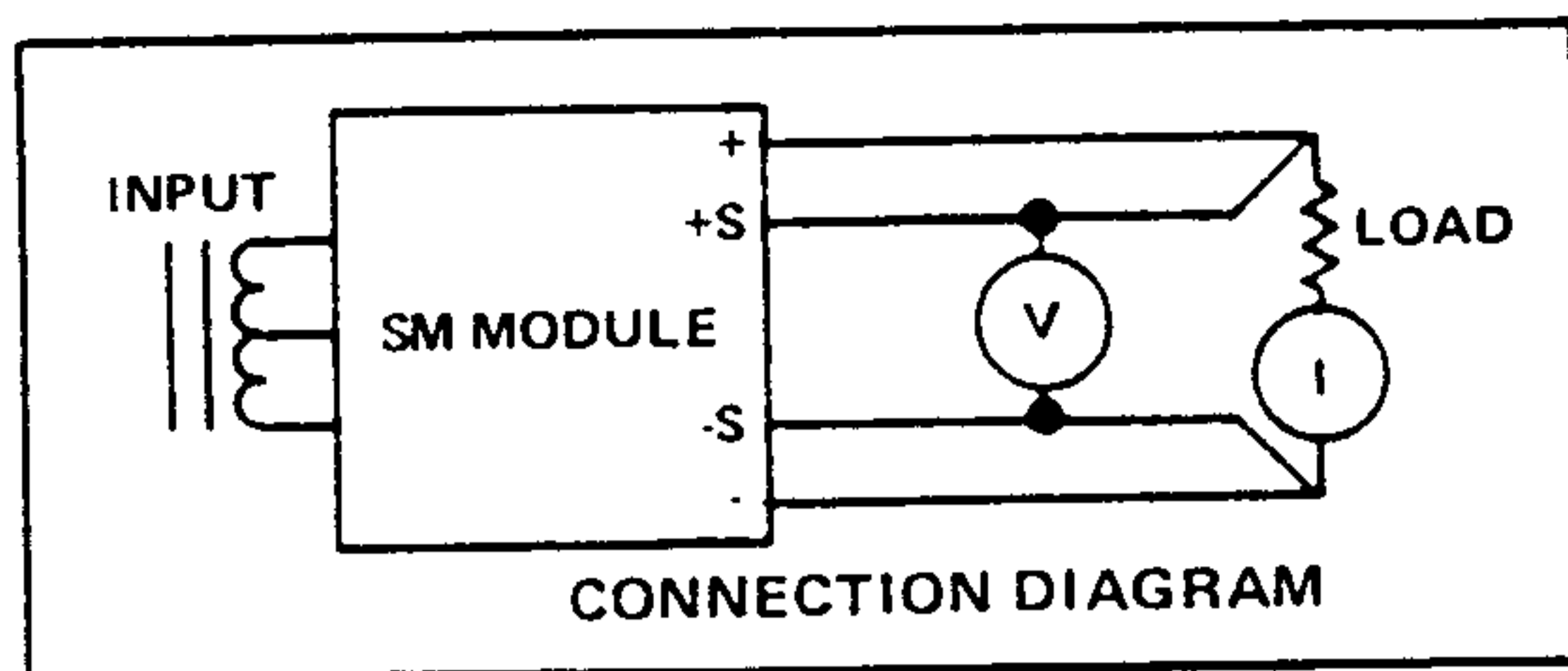

FIGURE A

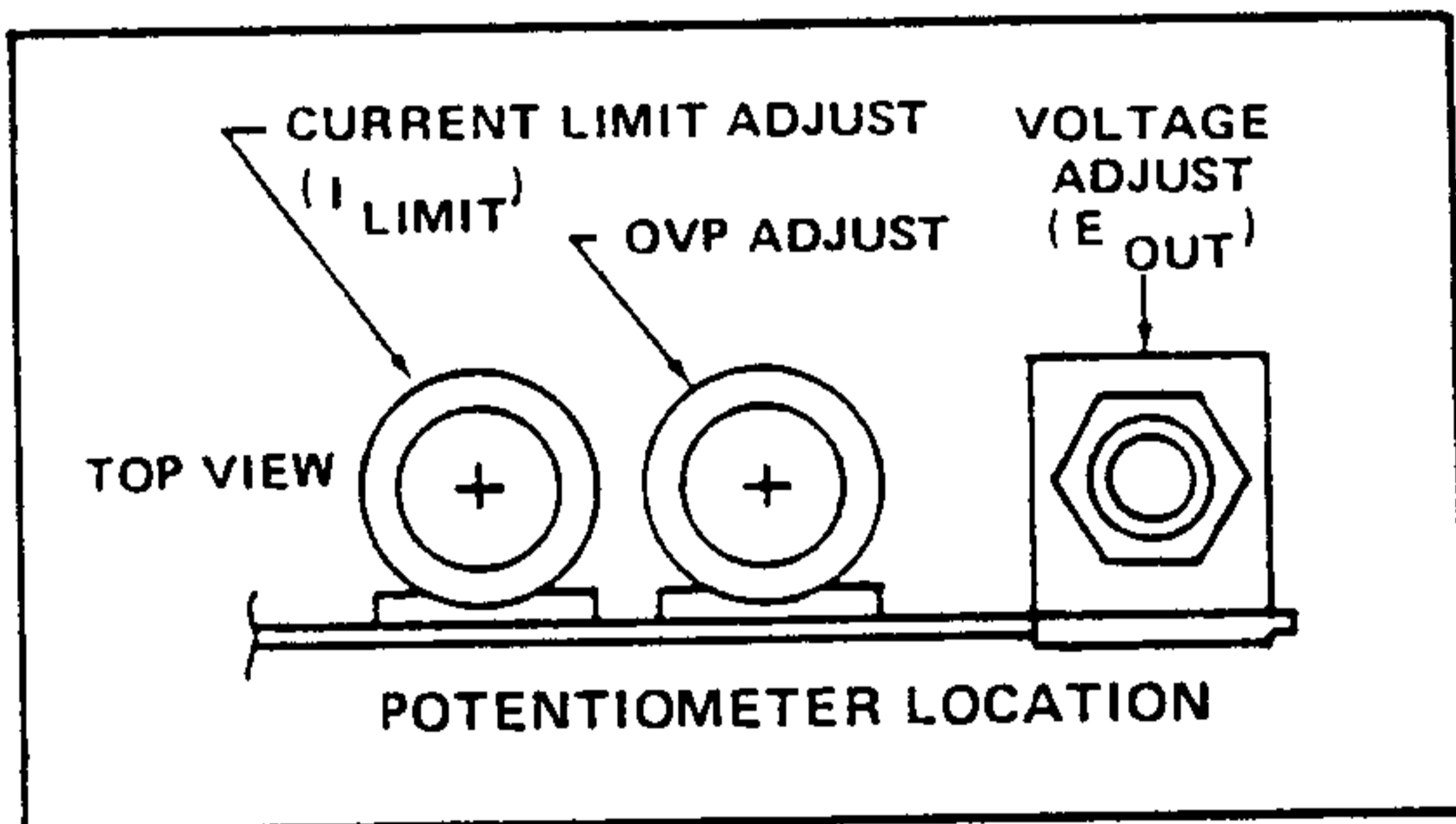

FIGURE B

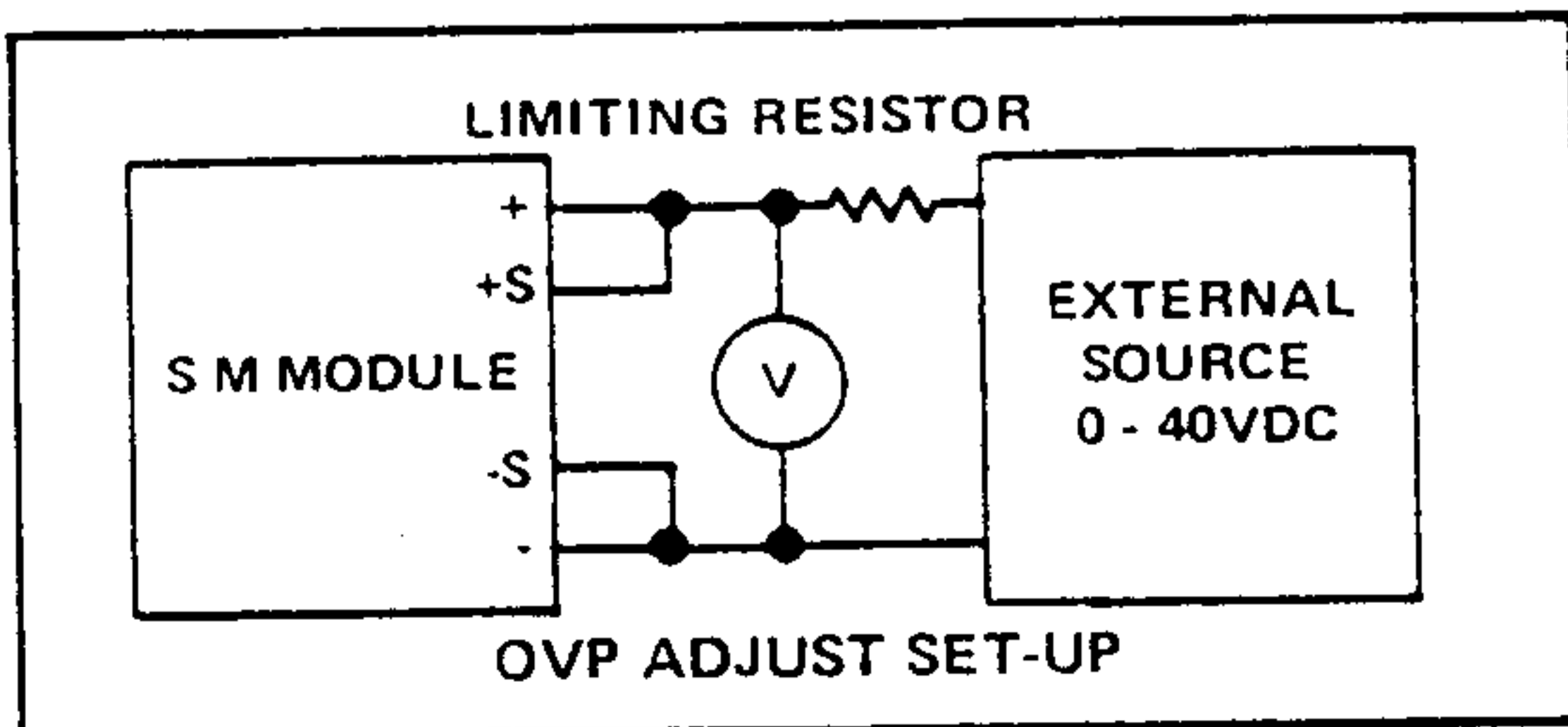

FIGURE C

D. MODEL 22B-300 (M1, M2, M3)  
REPLACEMENT PARTS LIST

REF DESIG	DESCRIPTION
C1, C6	Capacitor, Electrolytic, 220 uf, 35V
C2	Capacitor, Electrolytic, 4000 uf, 30V
C3, C5	Capacitor, Electrolytic, 1 uf, 50V
C4	Capacitor, Film, 0.001 uf, 50V
CR 1 thru CR4	Diode, Semtek 3F11, Motorola MR501
CR5	Diode, Zener, 1N4753A
CR6, CR8	Diode, 1N4002
CR7	Diode, Zener, 1N754A
F1	Fuse, 5 Ampere
Q1	Transistor, 2N2222A
Q2	Transistor, 13159-1
Q3	Transistor, 13002-3
Q4	Transistor, 2N2907A
R1, R2	Resistor, 750 Ohms, $\pm 5\%$ , 1/2 W
R3	Resistor, 470 Ohms, $\pm 5\%$ , 1/2 W
R4	Resistor, Not Used
R5	Resistor, 47K Ohms, $\pm 5\%$ , 1/2 W
R6, R9	Resistor, 1K Ohms, $\pm 5\%$ , 1/2 W
R18, R19	Resistor, Not Used
R7	Resistor, Not Used
R8	Resistor, 3.3K Ohms, $\pm 5\%$ , 1/2 W
R10	Resistor, 0.22 Ohms, BWH
R11	Potentiometer, 100 Ohms
R12	Resistor, Not Used
R13	Resistor, 1.2K Ohms
R14, R22	Potentiometer, 1.5K Ohms
R15	Resistor, 309 Ohms, RN60C
R16	Resistor, 1.19K Ohms, RN60C
R17	Resistor, 270 Ohms, $\pm 5\%$ , 1/2 W
R20	Resistor, 1.55K Ohms, RN60C
R21	Resistor, 750 Ohms, RN60C
R23, R24	Resistor, 10 Ohms, $\pm 5\%$ , 1/2 W
SCR1	Silicon Control Rectifier, 2N4441
U1	Integrated Circuit, 723CE

E. MODEL 22B-100 (M4)  
REPLACEMENT PARTS LIST

REF DESIG	DESCRIPTION
C1, C6	Capacitor, Electrolytic, 470 uf, 15V
C2	Capacitor, Electrolytic, 9000 uf, 15V
C3, C5	Capacitor, Electrolytic, 1 uf, 50V
C4	Capacitor, Film, 0.001 uf, 100V
CR1, CR2, CR6, CR8	Diode, 1N4002
CR3, CR4	Diode, Semtek 3F11, Motorola MR501
CR5	Diode, Not Used
CR7	Diode, Zener, 1N751A
Q1	Transistor, 2N2222A
Q2	Transistor, 13159-2
Q3	Transistor, 13002-3
Q4	Transistor, 2N2907
R1, R2	Resistor, 51 Ohms, $\pm 5\%$ , 1/2 W
R3	Resistor, 3.01K Ohms, RN60C
R4	Resistor, 4.02 K Ohms, RN60C
R5	Resistor, 47K Ohms, $\pm 5\%$ , 1/2 W
R6, R9	Resistor, 1K Ohms, $\pm 5\%$ , 1/2 W
R18, R19	Resistor, Not Used
R7	Resistor, Not Used
R8	Resistor, 3.3K Ohms, $\pm 5\%$ , 1/2 W
R10	Resistor, 0.1 Ohms, BWH
R11	Potentiometer, 100 Ohms
R12	Resistor, Not Used
R13	Resistor, 510 Ohms, $\pm 5\%$ , 1/2 W
R14	Potentiometer, 1.5K Ohms
R15	Resistor, Jumper
R16	Resistor, 1.5K Ohms, RN60C
R17	Resistor, 100 Ohms, $\pm 5\%$ , 1/2 W
R20	Resistor, 1K Ohms, RN60C
R21	Resistor, Jumper
R22	Potentiometer, 500 Ohms
SCR1	Silicon Control Rectifier, 2N4441
U1	Integrated Circuit, 723CE



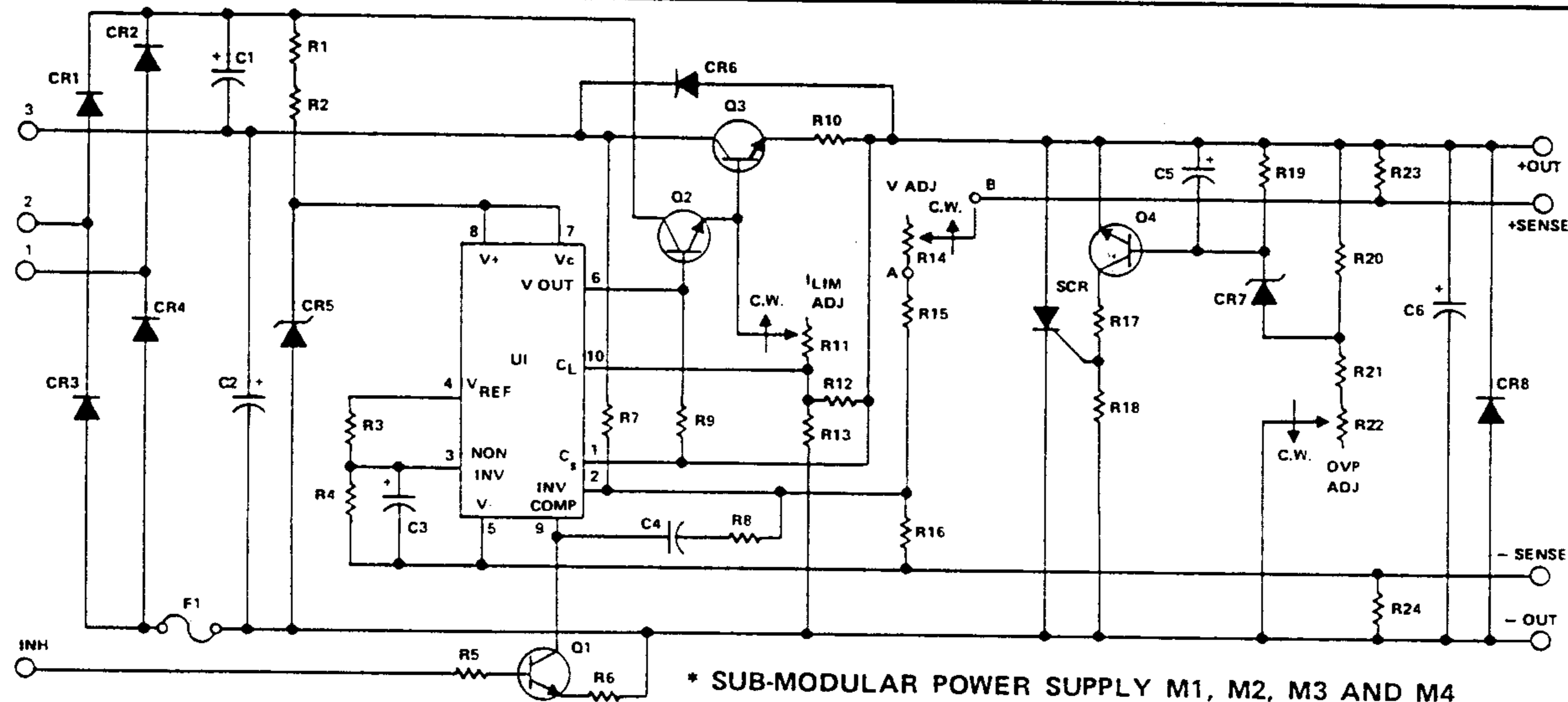

\* SUB-MODULAR POWER SUPPLY M1, M2, M3 AND M4

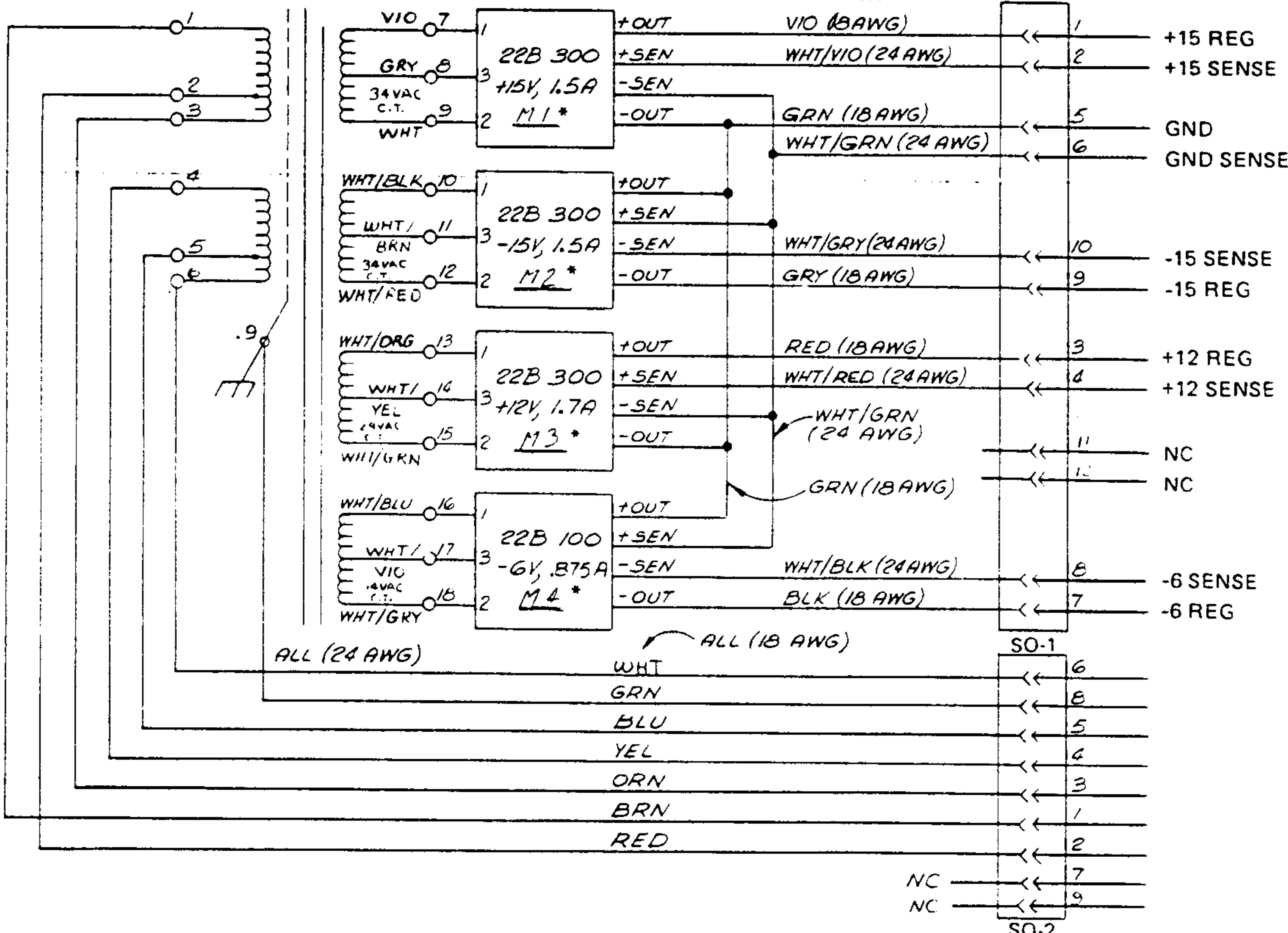

NOTES:

- NOMINAL RAW D.C. VOLTAGES (AT REGULATOR INPUT PIN 3)
- M1-3, +23.3 VDC  
M2-3, +8.3 VDC  
M3-3, +19.5 VDC  
M4-3, +3.0 VDC
- ALL NOMINAL VOLTAGES MEASURED WITH NO LOAD ON REGULATORS, 117 VAC 60 HZ INPUT ACROSS 1 AND 3 WITH 1-4 AND 3-6 STRAPPED.

# POWER SUPPLY MODEL 930

SUB-MODULAR POWER SUPPLY M1, M2, M3 (MODEL 22B-300) AND M4 (MODEL 22B-100)

## A. SPECIFICATIONS

Output Voltage:

+15V (M1), -15V (M2), +12V (M3), -6V (M4)

Output Current:

1.5A (M1, M2), 1.7A (M3), 2.5A (M4)

Line Regulation:  $\pm 0.075\%$  (M1 thru M4)

Load Regulation:  $\pm 0.075\%$  (M1 thru M4)

Ripple Peak-to-Peak: 5mV (M1 thru M4)

Over Current: 50%-130% of full rated load (M1 thru M4)

Over Voltage: 105%-135% of ratings (M1 thru M4)

## B. ADJUSTMENT PROCEDURES

**VOLTAGE ADJUST** - Adjust output voltage to desired level at no load with unit connected as shown in Figure A. Ascertain that OVP (Figure B) is in maximum clockwise position.

**CURRENT LIMIT ADJUST** - Adjust I LIMIT to maximum clockwise position. Apply 125% of full load and adjust I LIMIT until unit drops out of regulation 50 to 100mV.

### CAUTION

Do not run units over five minutes without additional heat sink.

**OVP ADJUSTMENT** - Remove input power and load and apply an external voltage through a limiting resistor as shown in Figure C. Adjust OVP ADJUST until firing occurs at desired voltage as the external source is slowly increased. Select limiting resistor to limit current to 0.5 ADC maximum after firing.

## C. TROUBLESHOOTING

TROUBLE	PROBABLE CAUSE
Input fuse blown.	<ol style="list-style-type: none"> <li>(1) Check fuse rating</li> <li>(2) Possible overload</li> <li>(3) OVP triggering with Q2, Q3, CR6 shorted</li> <li>(4) CR1, CR2, CR3, CR4, C1 or C2 shorted</li> </ol>
Low output voltage, poor regulation, high ripple, loaded.	<ol style="list-style-type: none"> <li>(1) Possible overload or current limit adjust R11 improperly adjusted (should be set for 120% of full load current prior to feedback)</li> <li>(2) Possible OVP triggering (check setting of R22)</li> <li>(3) U1 defective</li> <li>(4) C1, CR5, R4, C3, Q1, C4, R11, R14, R15, CR8 or C6 shorted</li> <li>(5) R1, R2, R3, R13 or R16 open</li> </ol>
High output voltage, poor regulation, high ripple, loaded.	<ol style="list-style-type: none"> <li>(1) V1 defective</li> <li>(2) Q2, Q3, CR6, R3 or R16 shorted</li> <li>(3) R4, R14 or R15 open</li> </ol>
High output voltage unloaded, OK loaded.	<ol style="list-style-type: none"> <li>(1) U1 defective</li> <li>(2) Q2 or Q3 high leakage</li> </ol>
Output noise.	<ol style="list-style-type: none"> <li>(1) U1 defective</li> <li>(2) C3 or C6 open</li> </ol>
Output oscillation.	<ol style="list-style-type: none"> <li>(1) U1 defective</li> <li>(2) C4, R8 or C6 open</li> </ol>
OVP triggers under normal operation	<ol style="list-style-type: none"> <li>(1) Check OVP setting</li> <li>(2) SCR1, Q4, CR7, R21 or R22 shorted</li> <li>(3) C5 or R20 open</li> </ol>
OVP fails to trigger.	<ol style="list-style-type: none"> <li>(1) SCR1, R17, Q4, CR7, R21 or R22 open</li> <li>(2) R18, R19 or C5 shorted</li> </ol>
Inhibit does not function. Excessive unit heating.	<ol style="list-style-type: none"> <li>(1) Possible overload</li> <li>(2) Inadequate heat sinking or heat sink bolted to uneven surface (no thermal compound used in heat sinking)</li> <li>(3) Input voltage too high</li> </ol>

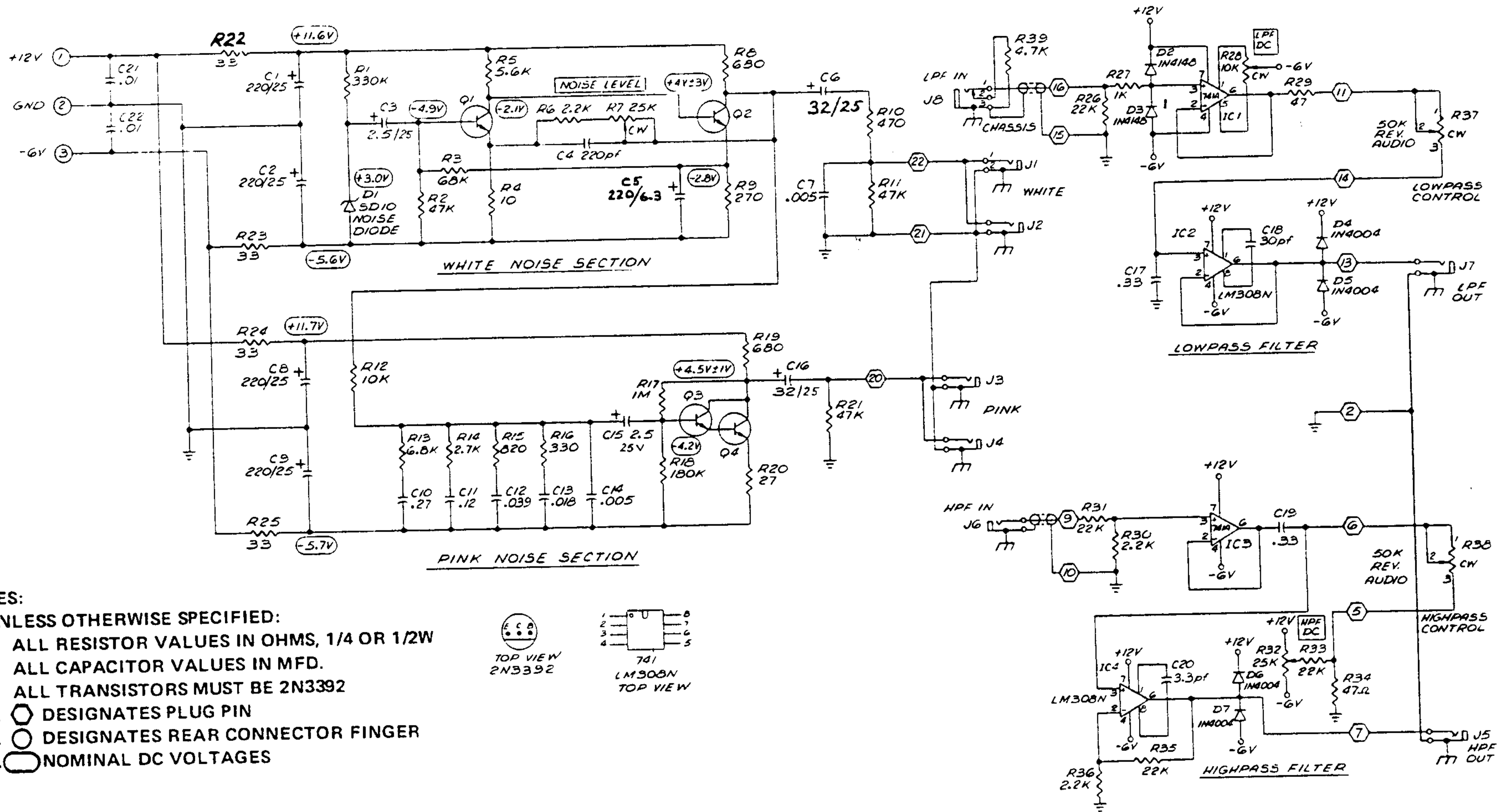

**NOTES:**

UNLESS OTHERWISE SPECIFIED:

1. ALL RESISTOR VALUES IN OHMS, 1/4 OR 1/2W
2. ALL CAPACITOR VALUES IN MFD.
3. ALL TRANSISTORS MUST BE 2N3392
4. ○ DESIGNATES PLUG PIN
5. ○ DESIGNATES REAR CONNECTOR FINGER
6. ○ NOMINAL DC VOLTAGES

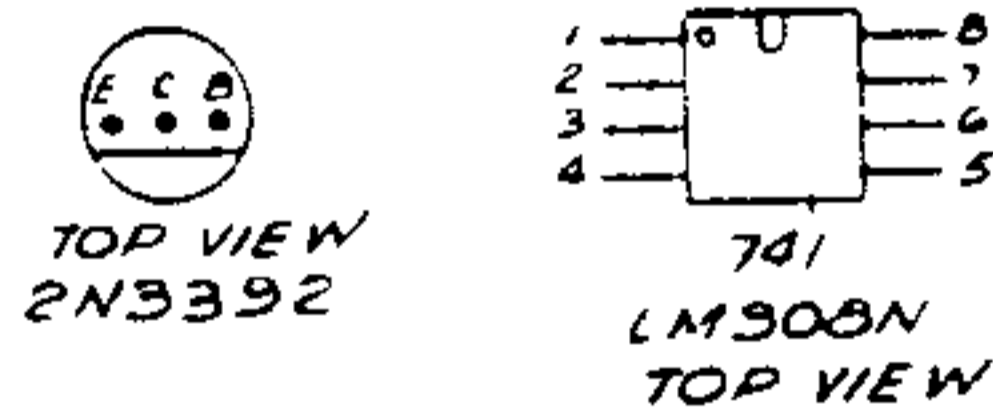

**MOOG MUSIC INC.**  
 SCHEMATIC, 923 FILTERS/NOISE SOURCE  
 993-041876 08-032

FIGURE 24 FILTERS/NOISE SOURCE MODEL 923

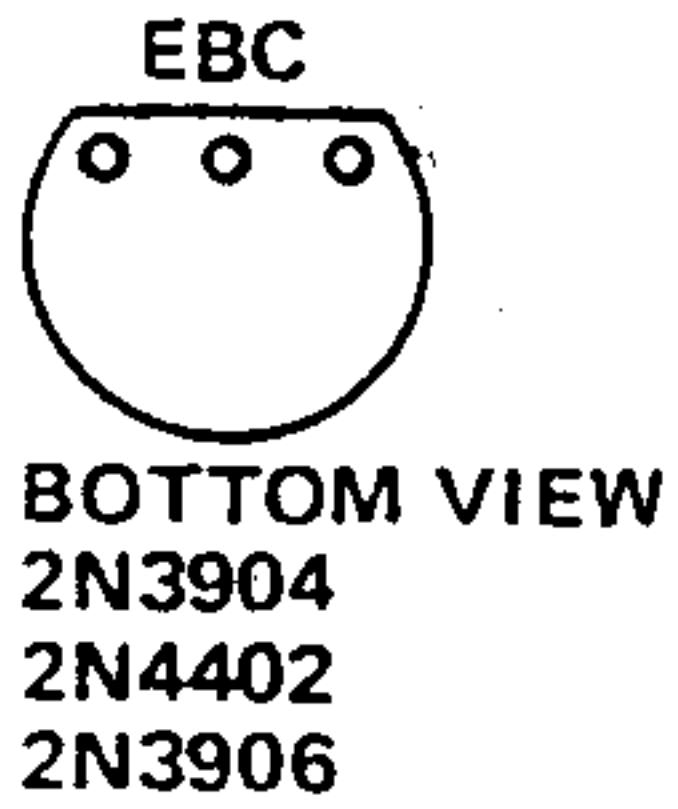
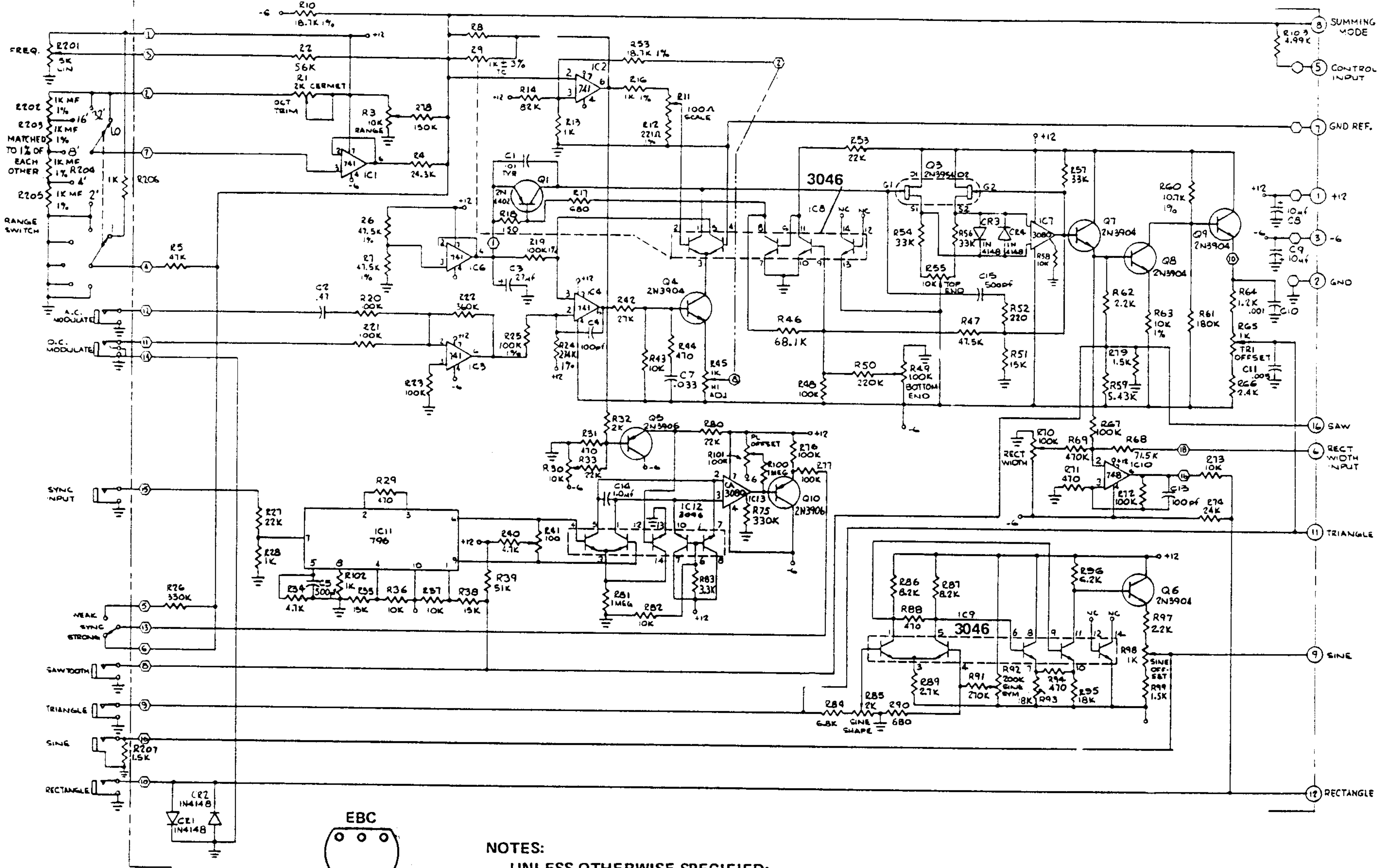

- NOTES:**
- 1. ALL RESISTOR VALUES IN OHMS, 1/4 OR 1/2W
  - 2. ALL CAPACITOR VALUES IN MFD.
  - 3. ○ DESIGNATES PLUG PIN
  - 4. ○ DESIGNATES REAR CONNECTOR FINGER

**MOOG MUSIC INC.**  
 SCHEMATIC, OSCILLATOR 921B  
 993-041875 08-013

FIGURE 23. OSCILLATOR MODEL 921B

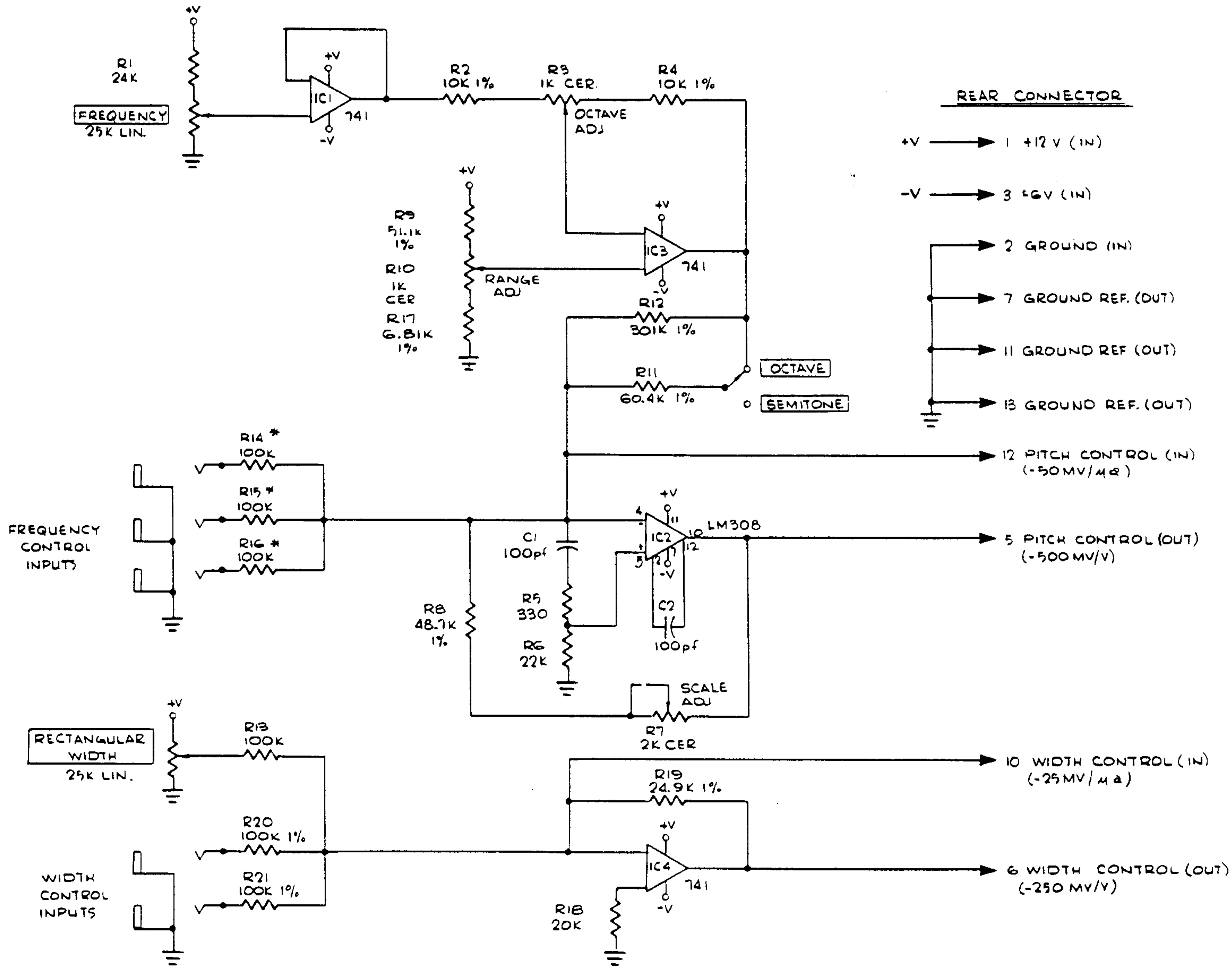

**REAR CONNECTOR**

- +V → 1 +12 V (IN)
- V → 3 -6 V (IN)
- 2 GROUND (IN)
- 7 GROUND REF. (OUT)
- 11 GROUND REF. (OUT)
- 13 GROUND REF. (OUT)

- NOTES:**
1. UNLESS OTHERWISE SPECIFIED ALL RESISTORS ARE ± 5%, 1/2 W.
  2. ALL 1% RESISTORS ARE 1/4 W.
  3. \* MATCHED TO 0.1%

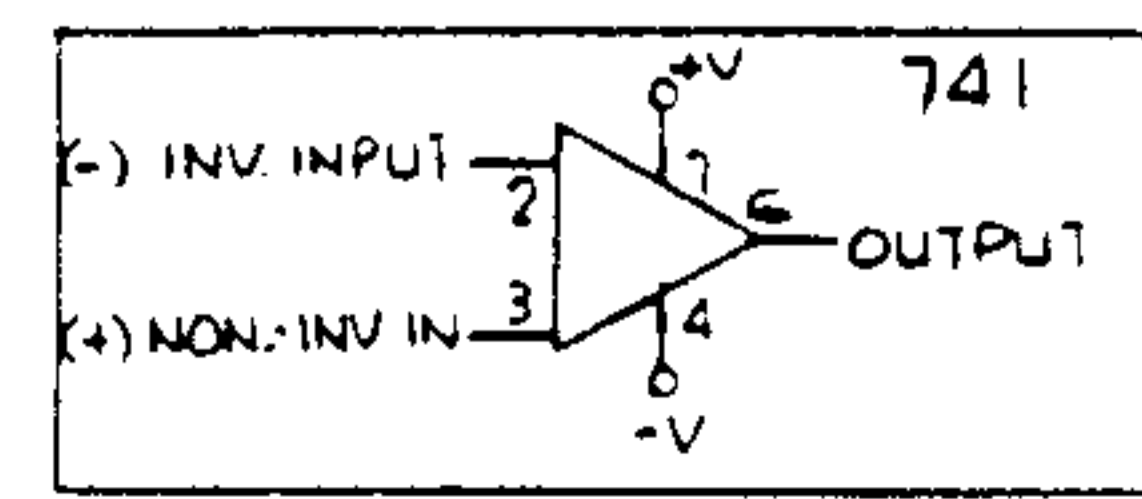

**MOOG MUSIC INC.**  
 SCHEMATIC, 921A-OSCILLATOR DRIVER  
 993-041835 08-009

FIGURE 22. OSCILLATOR DRIVER MODEL 921A

## NOTE

All voltages to be  $\pm 0.1\%$  unless otherwise specified.

- A. Check FREQUENCY and WIDTH control knobs for tightness and symmetrical positioning.
- B. Set OCTAVE, RANGE and SCALE trim pots to midrange.
- C. Connect dc voltmeter to output of power connector.
- D. Adjust FREQUENCY control for zero volts dc.
- E. Place OCTAVE/SEMITONE switch in SEMITONE position.
- F. Apply +2.0 volts to one of the CONTROL INPUTS and adjust SCALE trim pot for -1.0 volts output.
- G. Apply +2.0 volts to the other CONTROL INPUTS. Maximum tolerance between inputs will be 0.1%.

## NOTE

Applying +2.0 volts to any CONTROL INPUT will result in an output between -0.999 and -1.001 volts.

- H. Disconnect power to CONTROL INPUT.
- I. Place OCTAVE/SEMITONE switch in OCTAVE position.
- J. Connect low side of dc voltmeter to -6 VOLT (available at jumper) and connect high side to the OUTPUT.

- K. Adjust OCTAVE trim pot to obtain a 6.0 volt change between one end of the FREQUENCY control to the other.
- L. Connect low side of dc voltmeter to ground.
- M. Adjust RANGE trim pot for +3.0 volts with the FREQUENCY control in full counterclockwise position.
- N. Turn FREQUENCY control to full clockwise position. Voltmeter should indicate -3.0 volts.
- O. Adjust FREQUENCY control for 0.0 volt indication. Indicator dot on knob should align with "0" panel marking.
- P. Place OCTAVE/SEMITONE switch in SEMITONE position. Observe that no zero shift occurs.
- Q. Vary the range of FREQUENCY control and observe that voltmeter will vary from +0.5 in full counterclockwise position to -0.5 in full clockwise position.
- R. Connect dc voltmeter to point "A" and set WIDTH control to mid-position. DC level indication should be  $-1.5 \pm 0.2$  volts.
- S. Turn WIDTH control to full counterclockwise position and apply +4.0 volts to one of the WIDTH control inputs. Voltmeter should indicate  $-1.0 \pm 0.010$  volts.
- T. Check the other WIDTH control for the same result as in step "S".

## SUMMARY

- FREQUENCY:
- A) E OUT/E IN = -0.500
  - B) WHEN E IN = 0, E OUT = 0 (CONTROL AT "0")
- WIDTH:
- A) E OUT/E IN = -0.250
  - B) WHEN E IN = 0, E OUT = -1.50 (CONTROL AT "50")

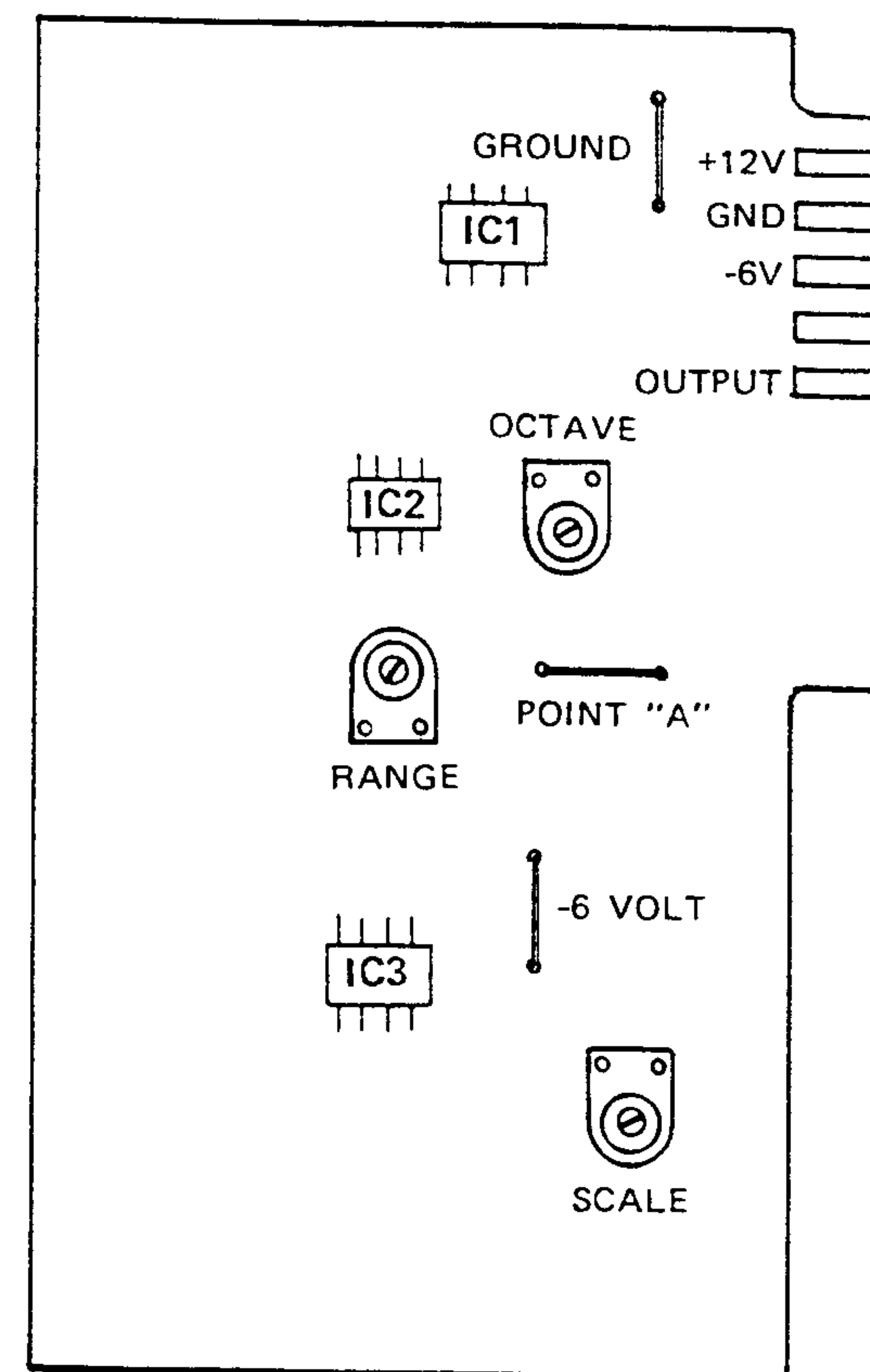

### NOTE

These procedures are for 921 and 921B Oscillators unless otherwise noted. All trimpots must be centered.

### WAVEFORMS

- Connect 921B to a tested 921A.
- Check SAWTOOTH output level for approximately -6dB.
- Check TRIANGULAR output. Adjust ① for no glitch on lowest frequency, adjust ② for 0 DC offset and check level for approximately -6dB.
- Check RECTANGULAR output (921A WIDTH to 50%). Adjust ③ for square wave and check level for -2dB.
- Check SINE output. Alternately adjust ④ and ⑤ for sine shape and symmetry, adjust ⑥ for 0 VDC offset and check level for -4dB.

### SCALING

### NOTE

The oscillator scaling procedure requires either monitoring the oscillator output with a frequency counter or "zero beating" the oscillator against a fixed frequency reference oscillator.

Tuning by the "zero beat" method ("by ear") is done by mixing the sawtooth outputs of the oscillator being scaled and a fixed frequency oscillator (a 921 or 921B from another bank) tuned to C:523Hz and monitoring the mixed output with the audio equipment normally used with the synthesizer. Viewing the mixed output on an oscilloscope is helpful but not necessary.

The actual tuning to exact frequencies is not of particular importance as the synthesizer offers a variety of accessible pitch controls. The only serious consideration is for scaling the oscillators and for having all the oscillators in the system track with one another, that is, that they oscillate at the same frequency over a wide range of control voltage inputs.

- Set the FREQUENCY of the 921A, 921B or 921 to 0. If using a Model 950 or 951 Keyboard, set the 921B or 921 RANGE to 8'. The RANGE should be set to 2' if a Model 952 Keyboard is used. Patch the keyboard output to the 921A or 921 FREQUENCY control input. Set the SCALE and RANGE controls on the keyboard to mid-position; set GLIDE or PORTAMENTO control off.

- Depress and hold C3 and adjust ① for 500Hz (or tune to unison with the reference oscillator).
- Depress and hold C1 and adjust ② for 125Hz (or two octaves below the reference). Repeat steps B and C until the scale is adjusted.
- Depress and hold C5 and adjust ③ for 2kHz (or two octaves above the reference). Repeat steps C and D (keep checking step B) until scaled.
- Check tracking by successively depressing each ④ on the keyboard. A well scaled oscillator should have a scale error of no more than  $\pm 1$ Hz.

### RANGE SWITCH SCALING

- Set RANGE switch to 2'. If using a Model 950 or 951 Keyboard, depress and hold C3. If a Model 952 Keyboard is used, depress and hold C5. Adjust ① for 2093Hz (or two octaves above reference).
- Switch RANGE to 32'. Adjust ② for 130.8Hz (or two octaves below reference).
- Check all RANGE positions for  $0 \pm 1$  Hz.

### NOTE

This will normally complete the tuning procedure. However, if large changes were required in any of the four trimmers used, it may be desirable to repeat the entire procedure.

The remaining oscillators may be tuned in exactly the same way. For best tracking results, use this already tuned oscillator as the reference for tuning the others. In this instance, instead of leaving the reference at the same pitch apply the same control voltages and range settings to the oscillator as well as the one to be tuned. All alignments are then made to unisons rather than several octaves apart. We are aware that this procedure is neither short nor simple but it will give excellent results and maximize your enjoyment of our fine instrument. A little practice with this procedure will greatly shorten the time required and improve your confidence in using the synthesizer.

### SYNCHRONIZATION ADJUSTMENTS

- Set RANGE to 8' (523Hz). Switch SYNCH. to STRONG and adjust ① for no frequency change.
- Check oscillator scale (SYNCH still on STRONG) by rotating RANGE switch.

- Apply a unison (523Hz) -2dB to 0dB square wave to the SYNCH. input. Rotate FREQUENCY pot clockwise and counterclockwise from 0. Locking range should be at least 2 semitones on either side of 0.

### CLAMPING POINT ADJUST (921 ONLY)

- Set RANGE to 4'. SCALE should be  $\pm 12$  semitones. Set FREQUENCY to 0, COARSE RANGE to sub audio, CLAMPING POINT to 2%, and AUX. OUTPUT LEVEL to 8.
- Apply fixed output SAWTOOTH waveform to another VCO control input. V-TRIG clamping by patching from AUX. OUTPUT SAWTOOTH. Turn clamping pot to 98% and adjust ① for lowest possible clamping point.

### FREQUENCY POT RANGE (921 ONLY)

- Set SCALE to +12 semitones. Adjust ② for a two octave plus one semitone range from full counterclockwise to full clockwise.

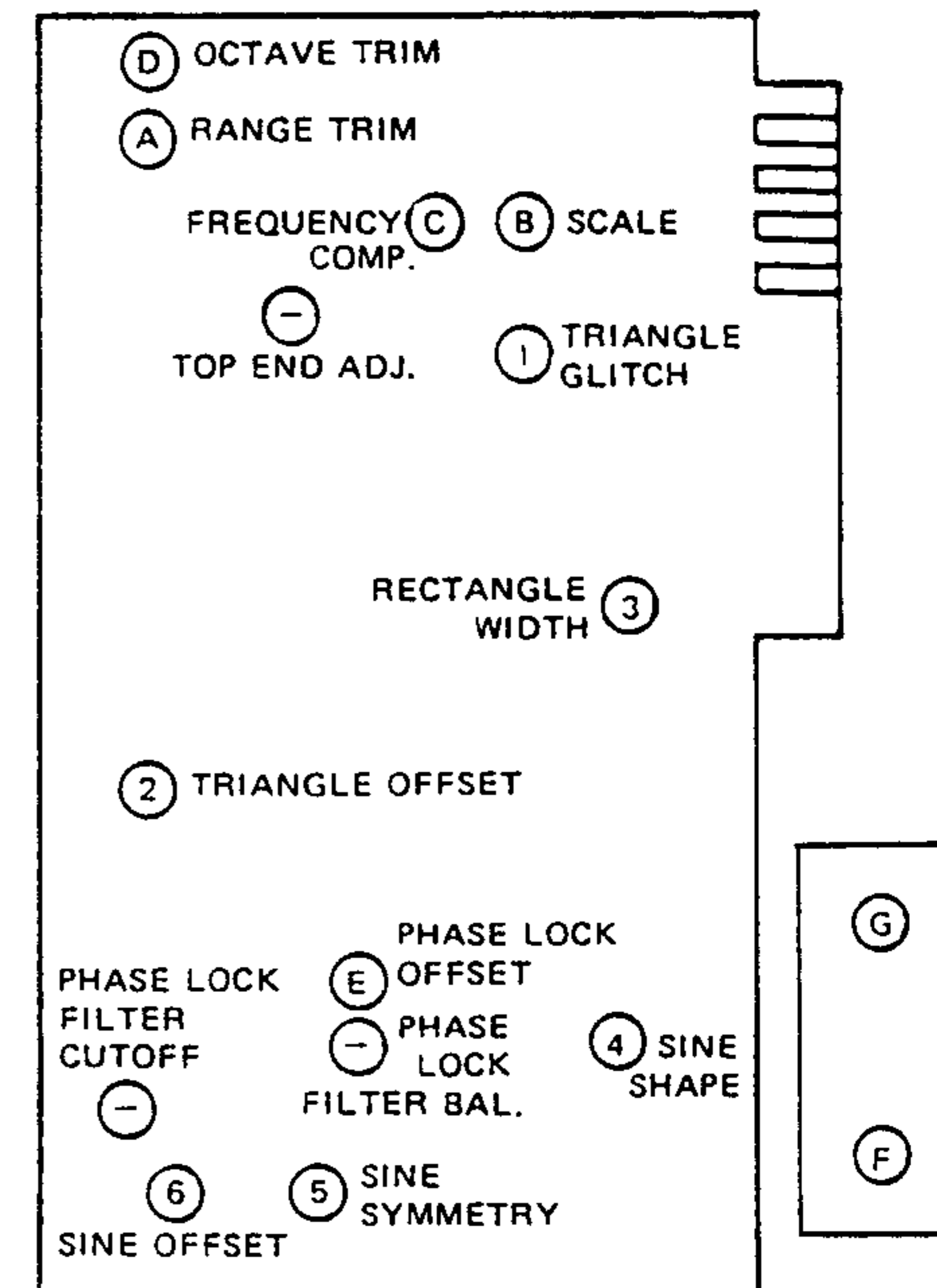

ADJUSTMENT LOCATION DIAGRAM

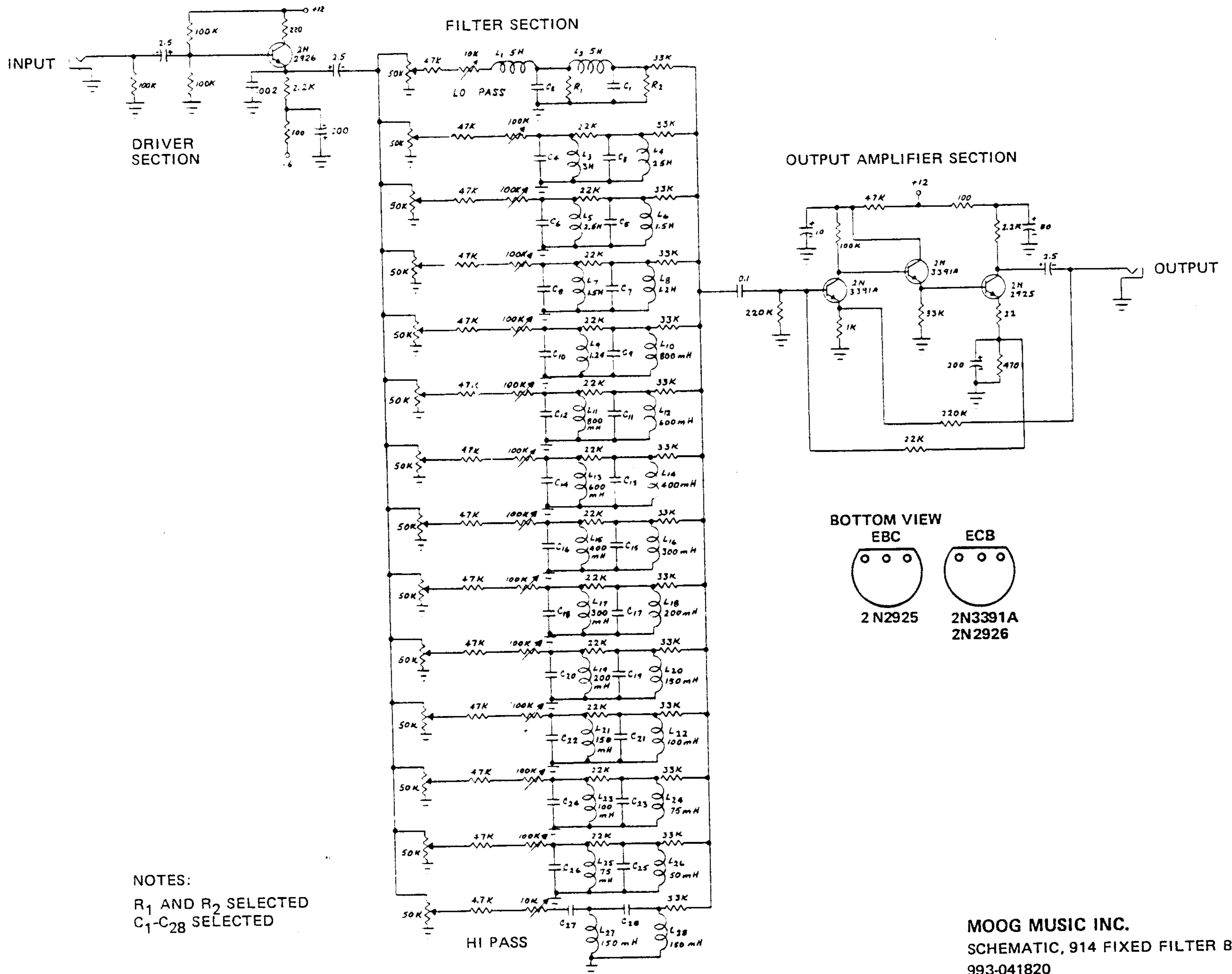

MOOG MUSIC INC.  
 SCHEMATIC, 914 FIXED FILTER BANK  
 993-041820

FIGURE 20. FIXED FILTER MODEL 914



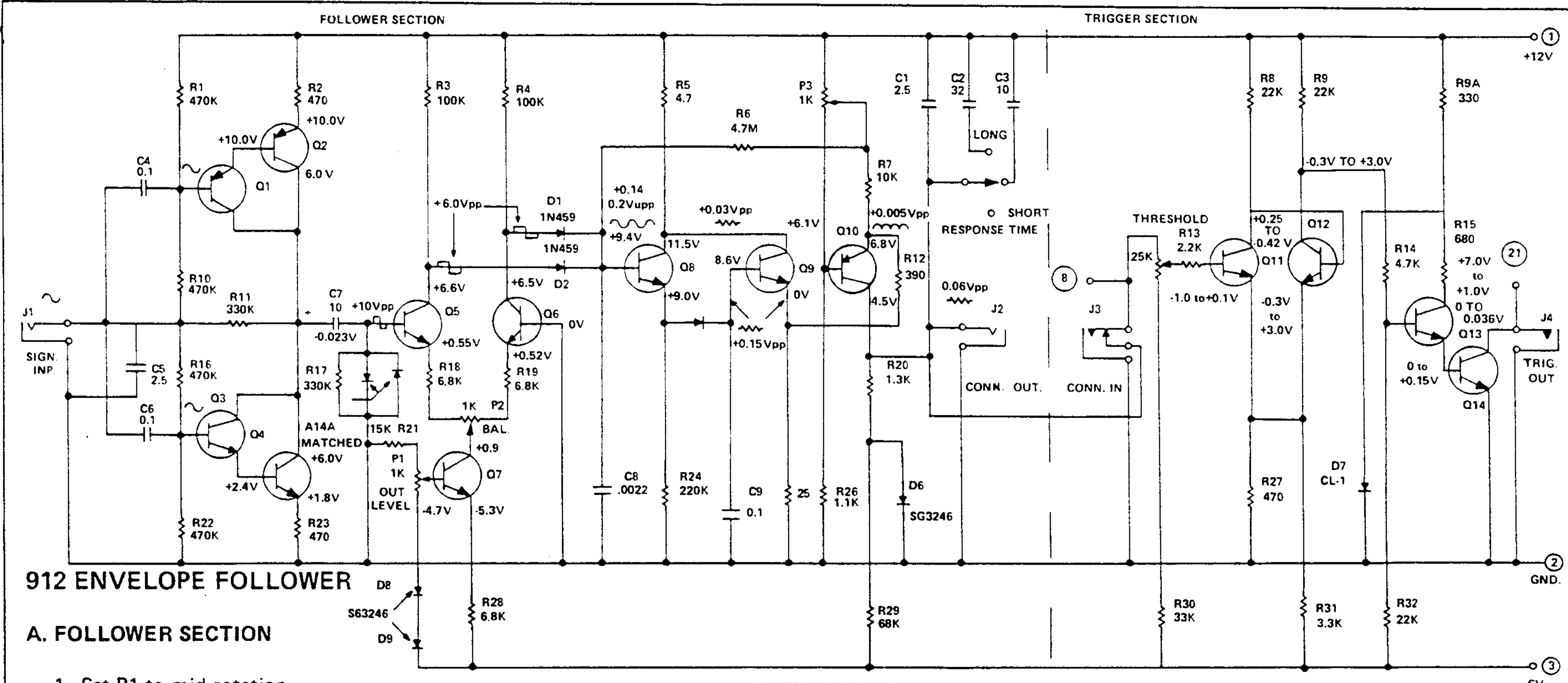

**912 ENVELOPE FOLLOWER**

**A. FOLLOWER SECTION**

1. Set P1 to mid-rotation.
2. Apply a 250Hz sine wave at -15db to the SIGNAL INPUT (J1).
3. Set P4 for 4.5 volts dc at the CONTROL OUTPUT (J2).
4. Adjust P3 to even the "TOPS" of the peaks of the sine wave, with response ON, as observed on oscilloscope connected at CONTROL OUTPUT (symmetry). Repeat steps 3 and 4 to maintain proper dc output. If necessary, change R21 from 15K to

6.5K for a 4.5V indication.

5. Check input/output levels as shown below with a 250Hz sine wave.

INPUT (db)	OUTPUT (volts)	
+3	6.0	±0.1V
-3	5.5	
-9	5.0	
-15	4.5	
-21	4.0	±0.2V
-27	3.5	
-33	3.0	
-39	2.4	
-45	1.8	
-51	1.1	
-57	0	

**B. TRIGGER SECTION**

1. Apply a -42db signal to SIGNAL INPUT (J1).
2. Connect dc voltmeter across TRIGGER OUTPUT (J4). As THRESHOLD control (R13) is rotated counterclockwise, trigger output of approximately 50MV will occur at mid-range of rotation.

**NOTE**  
Utilize a 912 Envelope Follower to trigger a 921, 902 and 911 setup to determine proper operation of trigger threshold.

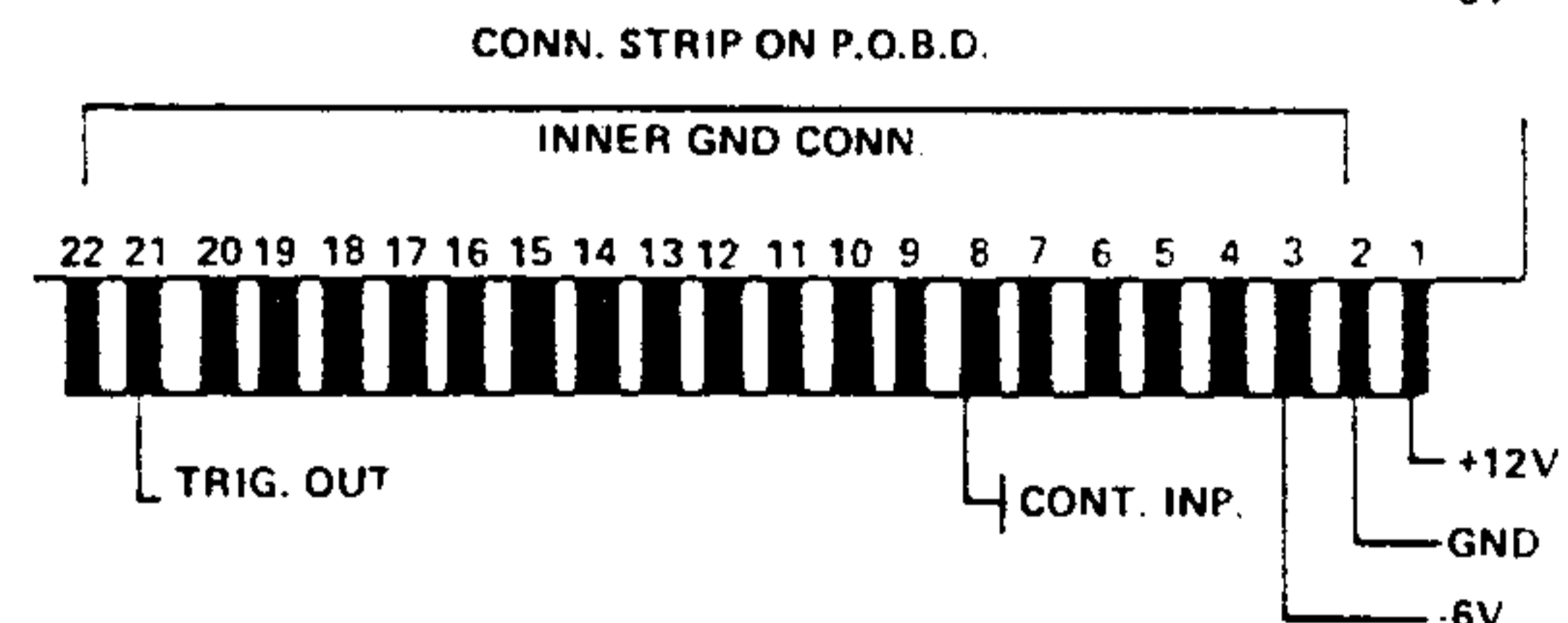

**NOTES: UNLESS OTHERWISE NOTED:**

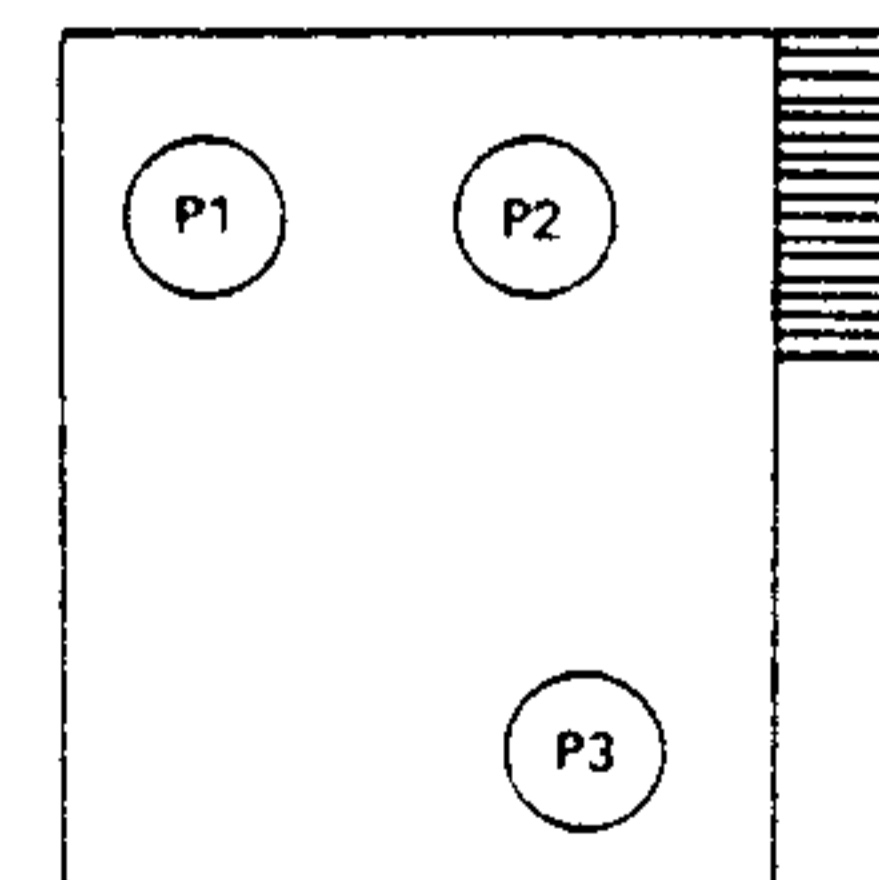

**ADJUSTMENT LOCATION DIAGRAM**

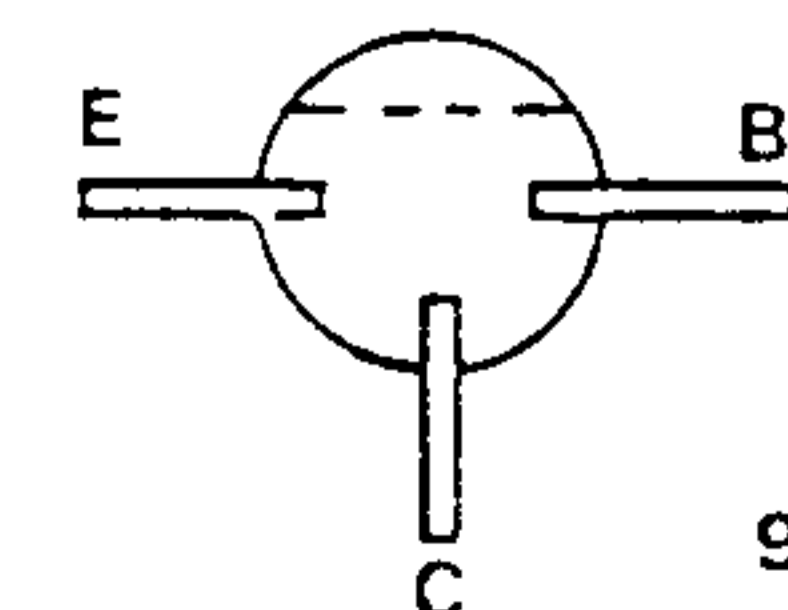

1. ALL RESISTORS IN OHMS
2. ALL CAPACITORS IN  $\mu$ f
3. ALL NPN TRANSISTORS = 2N3392
4. ALL PNP TRANSISTORS = 2N4058
5. ALL DC VOLTAGES  $\pm$  20% MEASURED WITH 250Hz -15db SIGNAL AT SIGNAL INPUT
6. VOLTAGES READ WITH THRESHOLD CONTROL GOING FROM FULL CW TO FULL CCW
7. BASE LAYOUT FOR TRANSISTORS USED:

**FIGURE 19 ENVELOPE FOLLOWER MODEL 912**

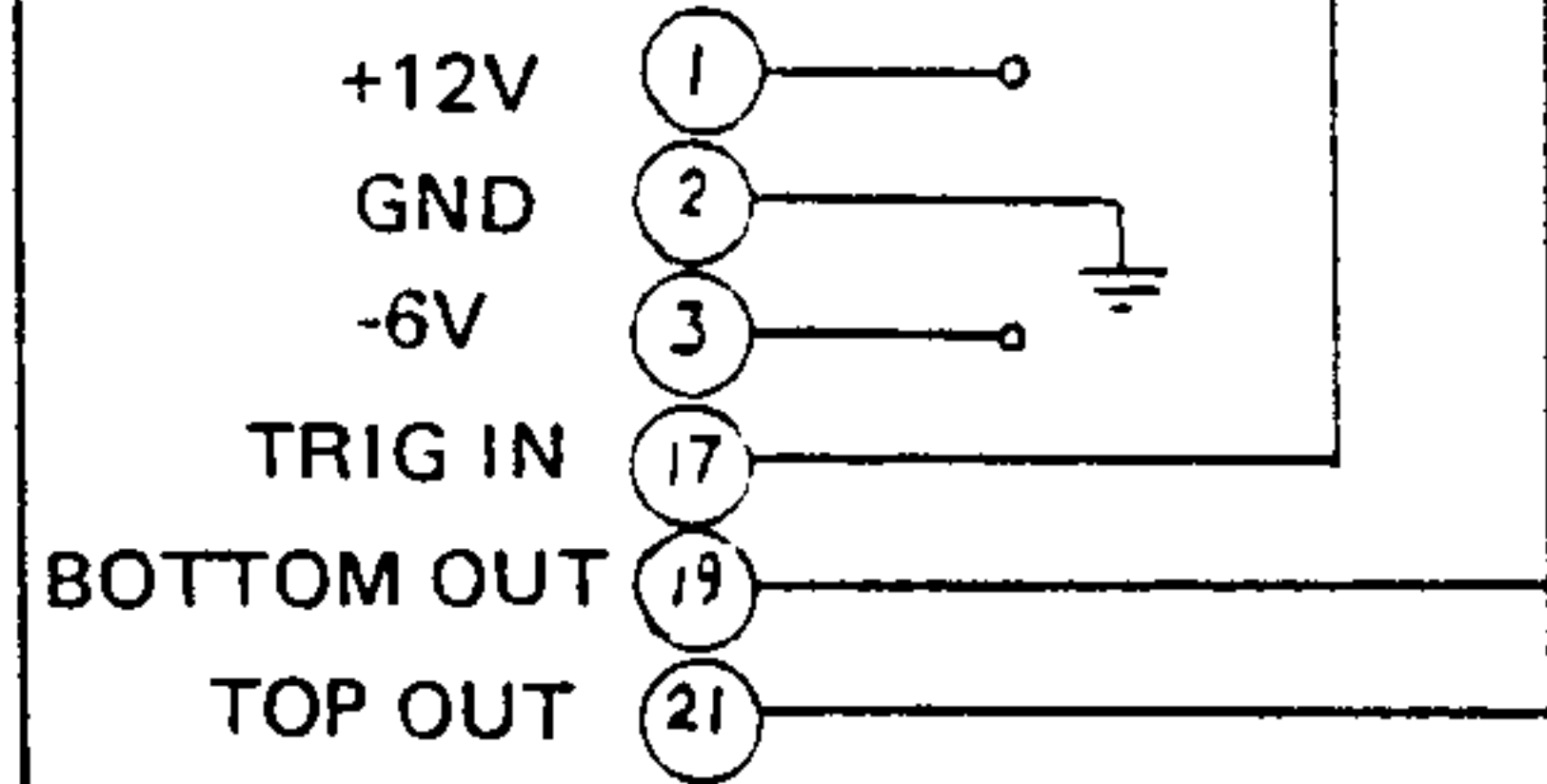
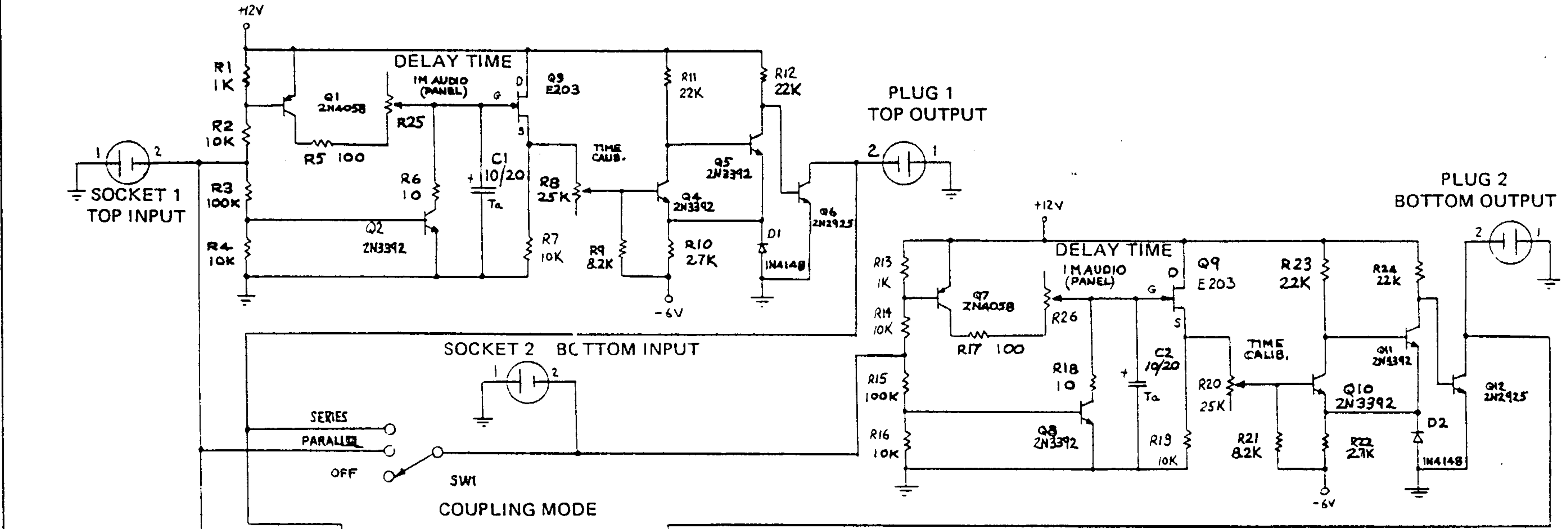

REAR CONNECTOR

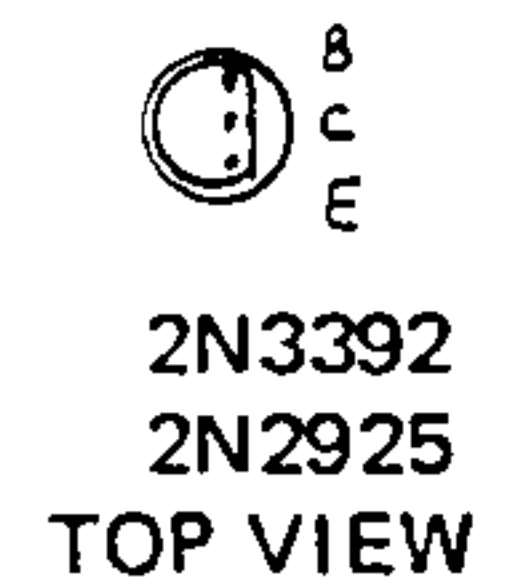

NOTE: 2N3392 TRANSISTORS  
MUST BE USED FOR  
REPLACEMENTS  
RESISTORS IN OHMS UNLESS  
OTHERWISE NOTED

MOOG MUSIC INC.  
SCHEMATIC, 911A-DUAL TRIGGER DELAY  
993-041780  
08-029

FIGURE 18 DUAL TRIGGER DELAY MODEL 911A

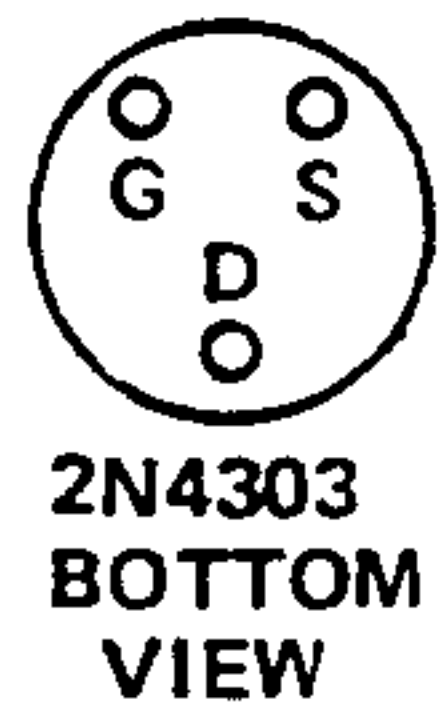
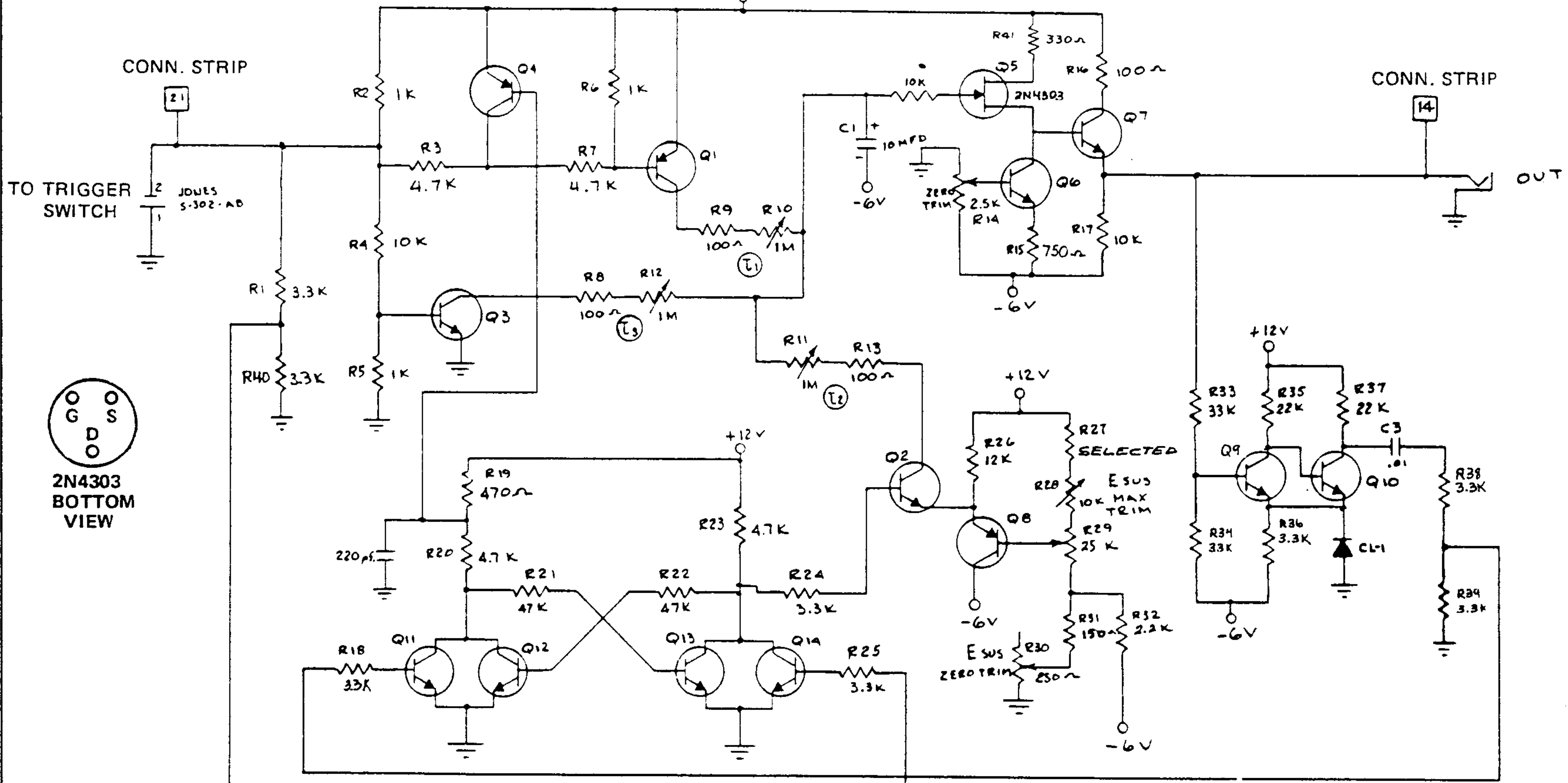

NOTES:

1. ALL PNP TRANSISTORS ARE 2N4058
2. ALL NPN TRANSISTORS ARE 2N3392
3. VALUE OF R27 SELECTED TO MEET  $E_{SUS}$  SPEC.

T1=10 SECONDS  
 T2=2 MILLISECOND  
 T3=10 SECONDS  
 $E_{SUS} = 10$

ENVELOPE GENERATOR  
 ALIGNMENT PROCEDURE AND  
 ADJUSTMENT LOCATION  
 DIAGRAM

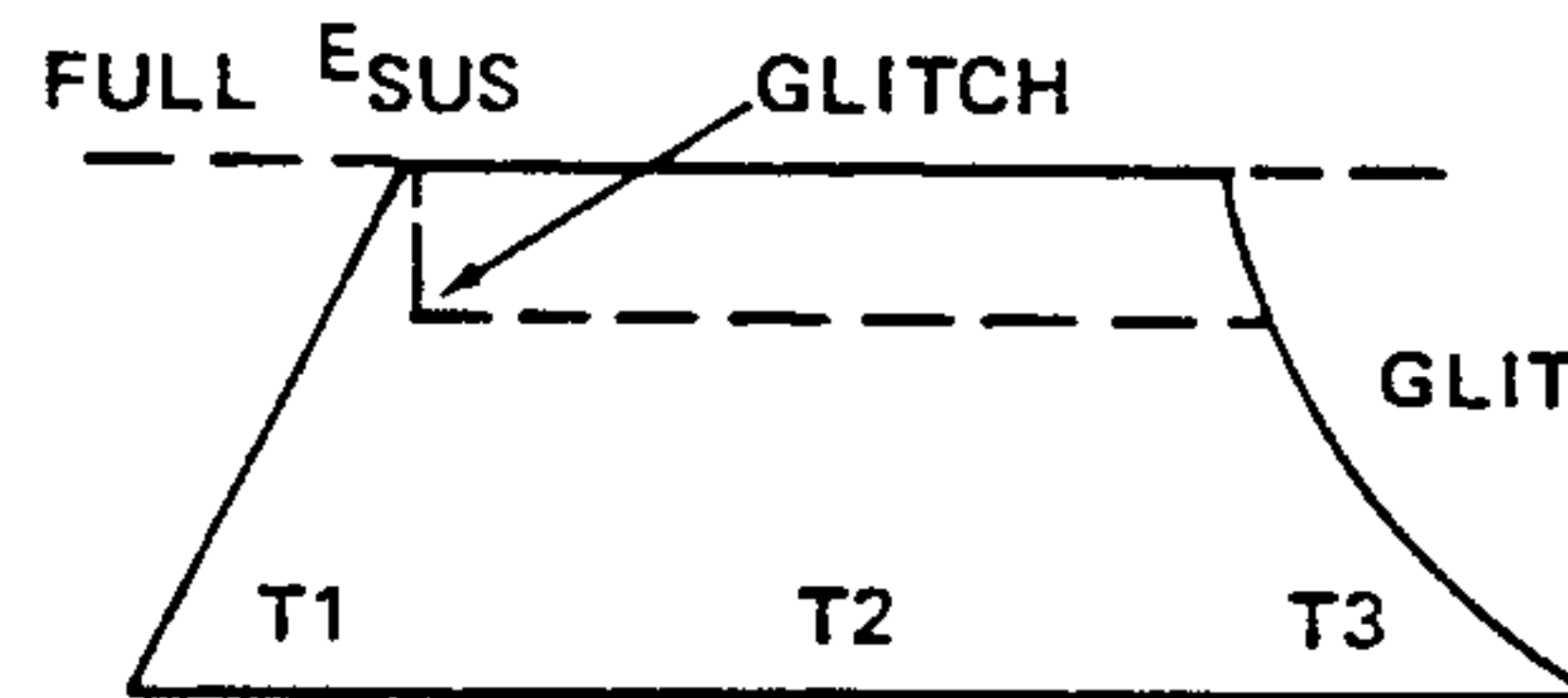
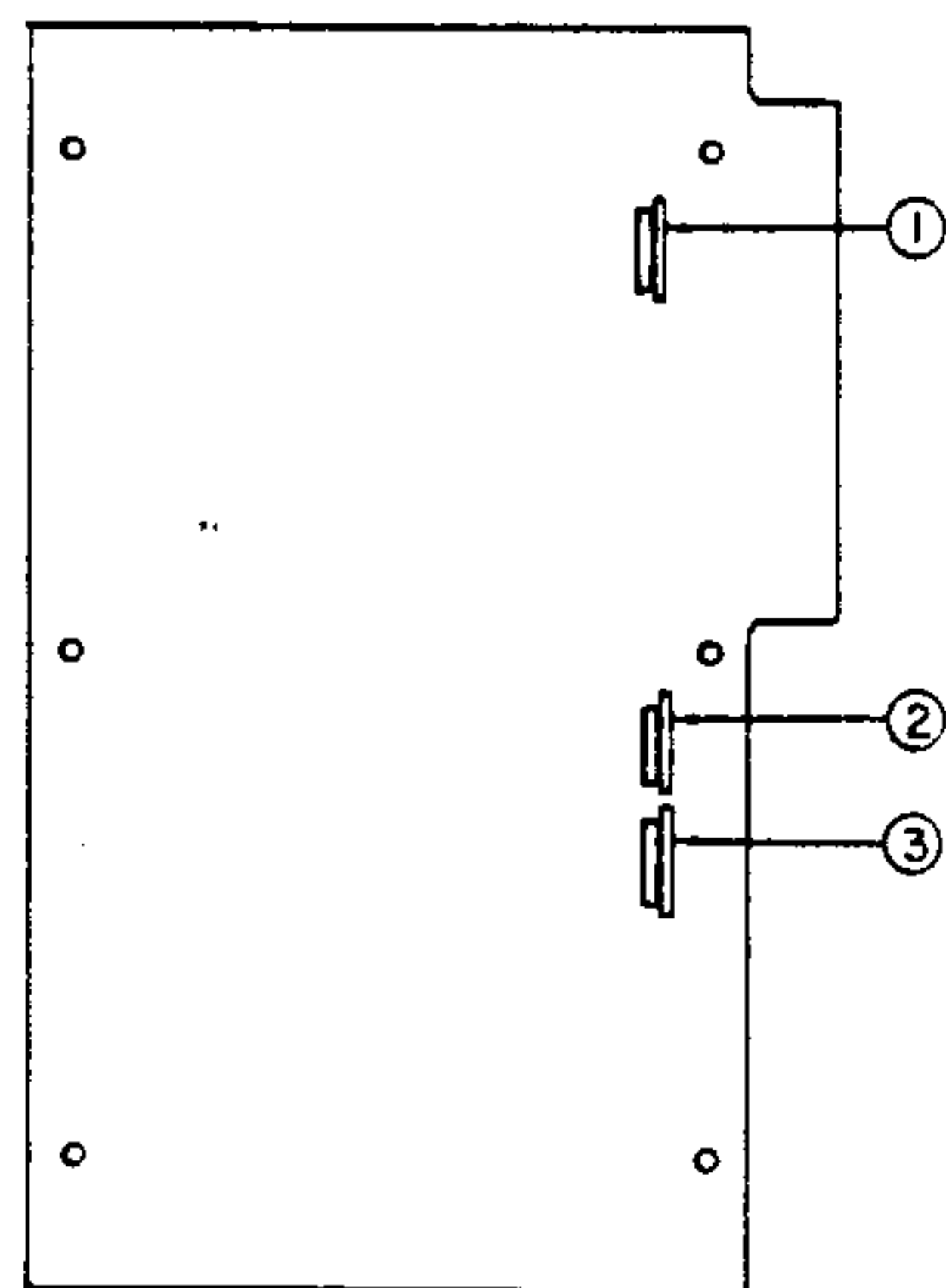

- ① Adjusts a zero output with no trigger with all panel controls fully counterclockwise.
- ② Adjusts glitch between top of attack slope and full sustain.
- ③ Adjusts a zero output offset with all panel controls fully counterclockwise.

MOOG MUSIC INC.

SCHEMATIC, 911, ENVELOPE GENERATOR

993-041815

1220

FIGURE 17 ENVELOPE GENERATOR MODEL 911

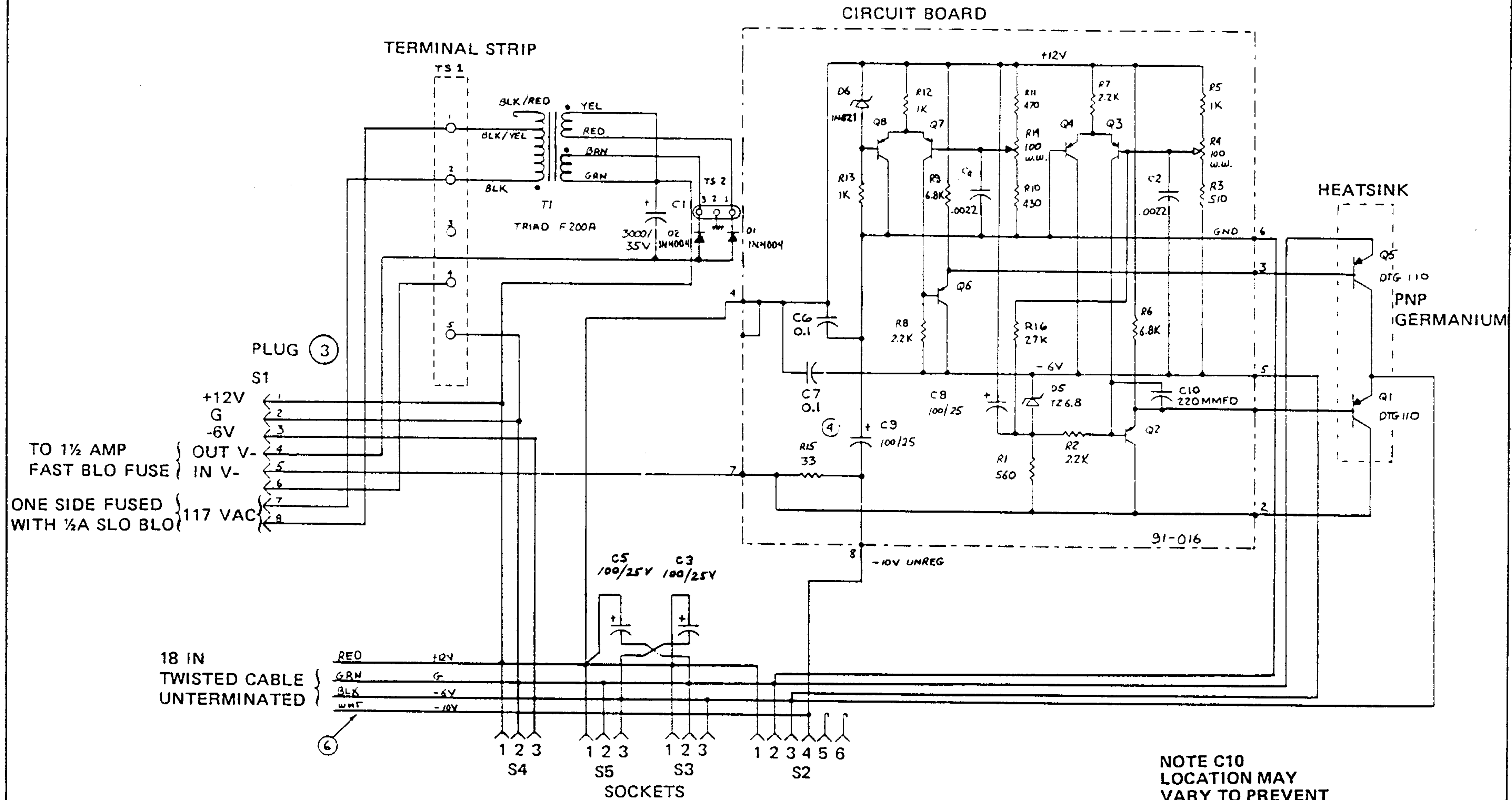

NOTE C10  
LOCATION MAY  
VARY TO PREVENT  
OSCILLATION

TOP VIEW DTG 110  
CASE = COLLECTOR

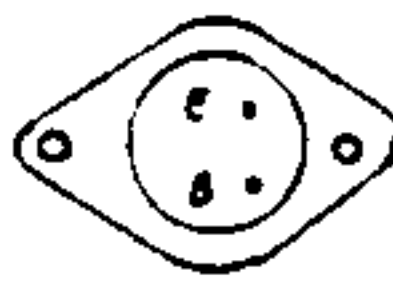

- ⑥ WHT WIRE 910 ONLY
- ⑤ UNUSED DESIGNATORS: D3, D4
- ④ MODEL 909 HAS R15 AND C9 REMOVED (NO -10V UNREG. OUTPUT)
- ③ MODEL 910 HAS 8-PIN SOCKET IN PLACE OF 8-PIN PLUG
- ② BASIC UNIT AS STOCKED
- ① ALL TRANSISTORS 2N 3702 UNLESS MARKED OTHERWISE

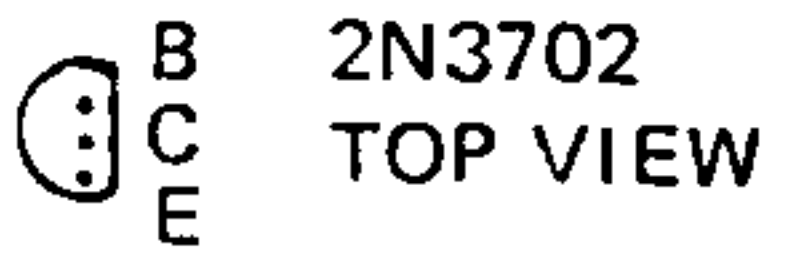

MOOG MUSIC INC.  
SCHEMATIC, POWER SUPPLY MODEL 909 & 910  
994-042128  
08-011

FIGURE 16 POWER SUPPLY MODELS 909 AND 910

5H

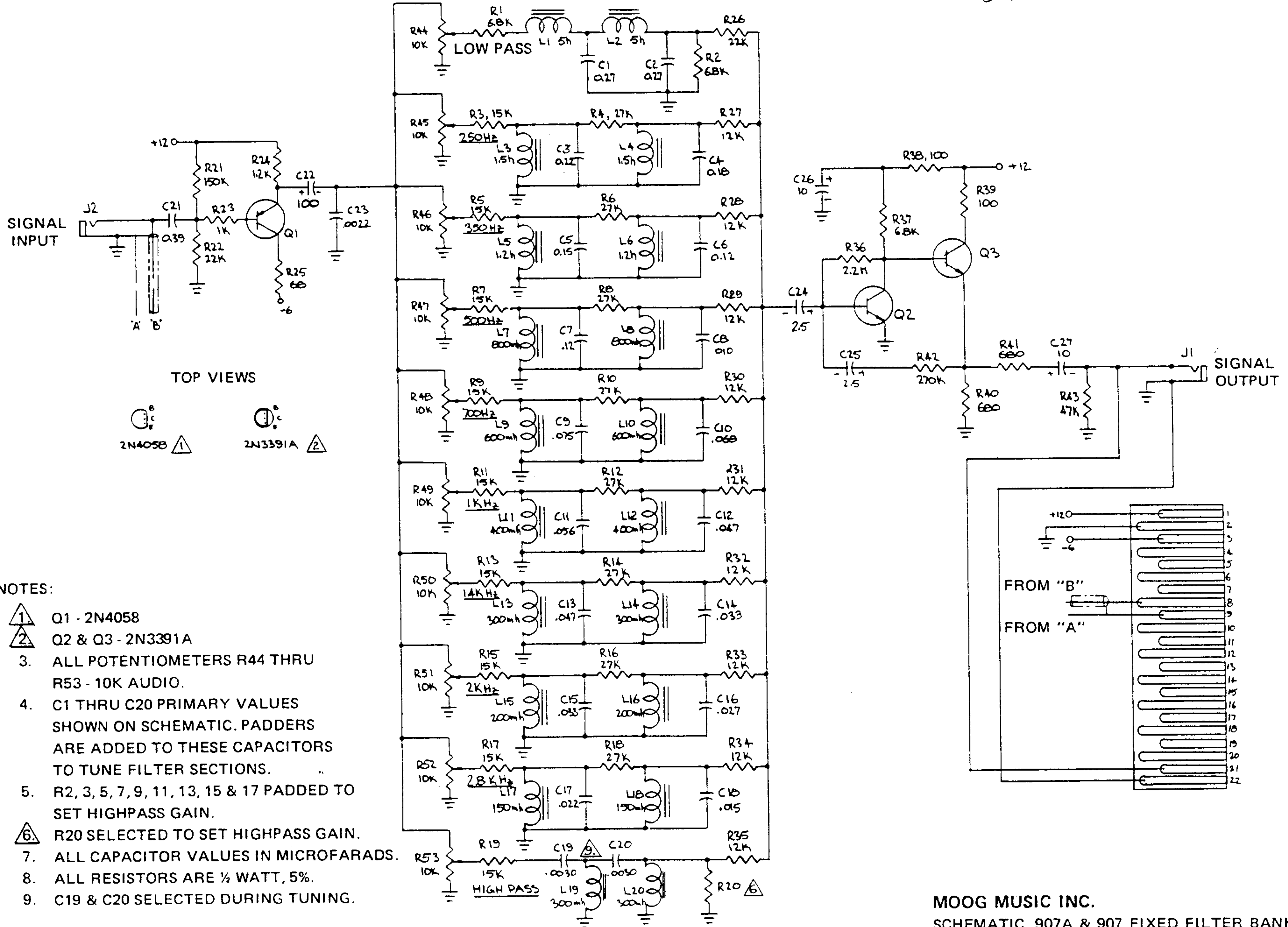
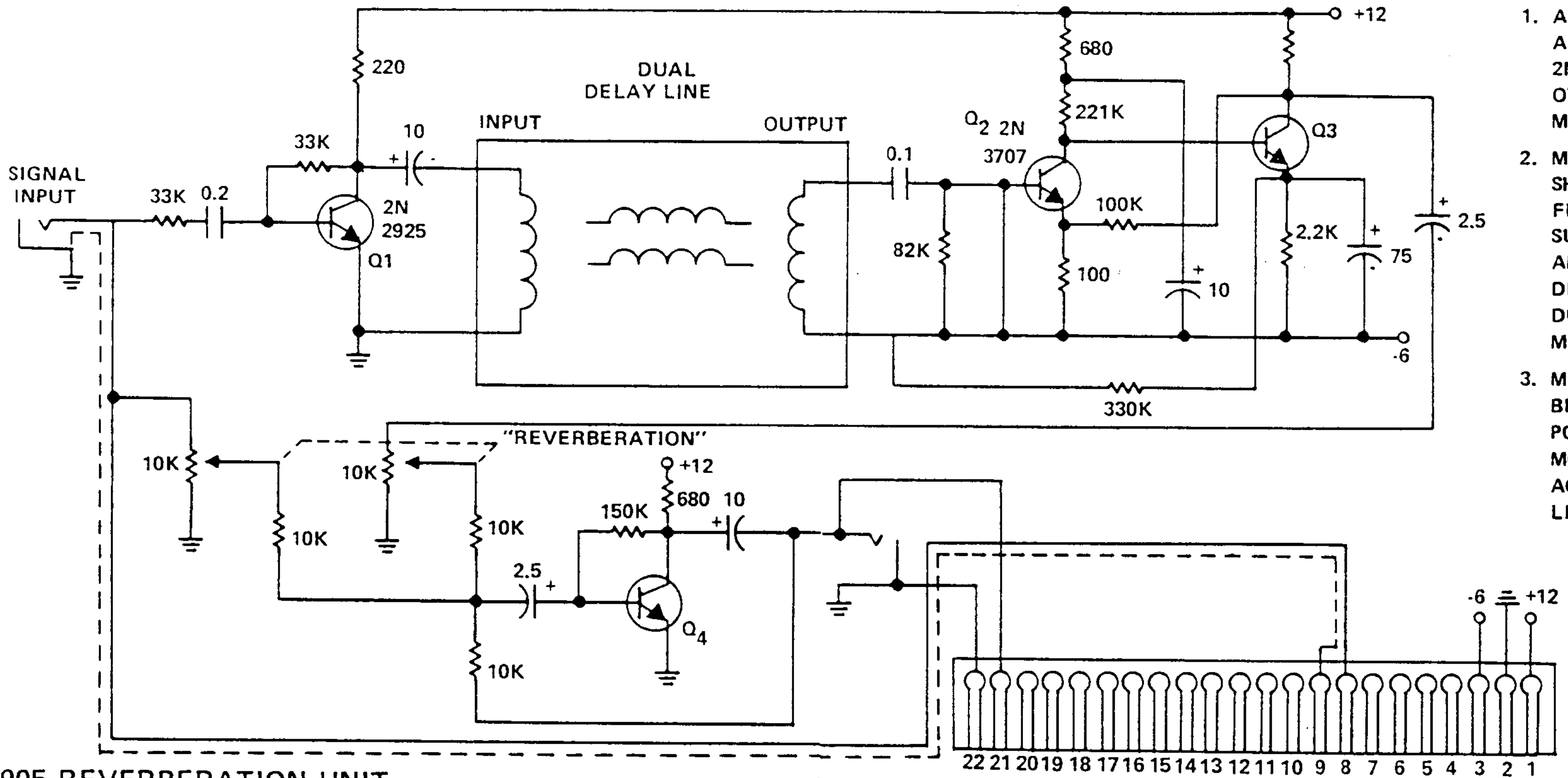

FIGURE 15 FIXED FILTER BANK MODELS 907 AND 907A



- NOTES:**
1. ALL TRANSISTORS ARE 2N2926 OR 2N3707 UNLESS OTHERWISE MARKED
  2. MOUNTING SHOULD BE AWAY FROM POWER SUPPLIES, MOTORS AND OTHER DEVICES PRODUCING STRONG MAGNETIC FIELDS
  3. MOUNTING SHOULD BE AS RIGID AS POSSIBLE TO AVOID MOVEMENT OF THE ACOUSTIC DELAY LINE

**905 REVERBERATION UNIT**

**A. GENERAL**

The 905 Reverberation Unit utilizes a dual spring-type acoustic delay line to produce a succession of decaying echoes of an audio signal. A single panel control determines the ratio between the amounts of reverberated and non-reverberated signals that appear at the output jack. The front panel control does not alter the characteristic decay time of the echoes, since this is a function of the delay line itself.

Instructions for mounting and connecting of power, and input and output characteristics, are the same as those which apply to all 900 series modules. However, special consideration in mounting the 905 must be observed. First, power supplies, motors and other devices producing

strong magnetic fields should be kept away from this instrument to avoid the pickup of power line frequency hum. Second, the mounting should be rigid to avoid shaking the acoustic delay line which would result in unwanted output signals. Third, monitor speakers should not be mounted close to the 905, as this would encourage acoustic feedback between speaker and delay line.

Before the 905 is installed, fittings and wrappings restricting the motion of the delay line should be removed. When the 905 is mounted vertically, the delay line bracket will be supported entirely by the suspension springs, and should not touch the chassis frame.

**B. APPLICATIONS**

When a dynamically varying signal is applied to the input of the 905, the output will consist of a series of closely spaced echoes, the subjected

**BOTTOM VIEW**

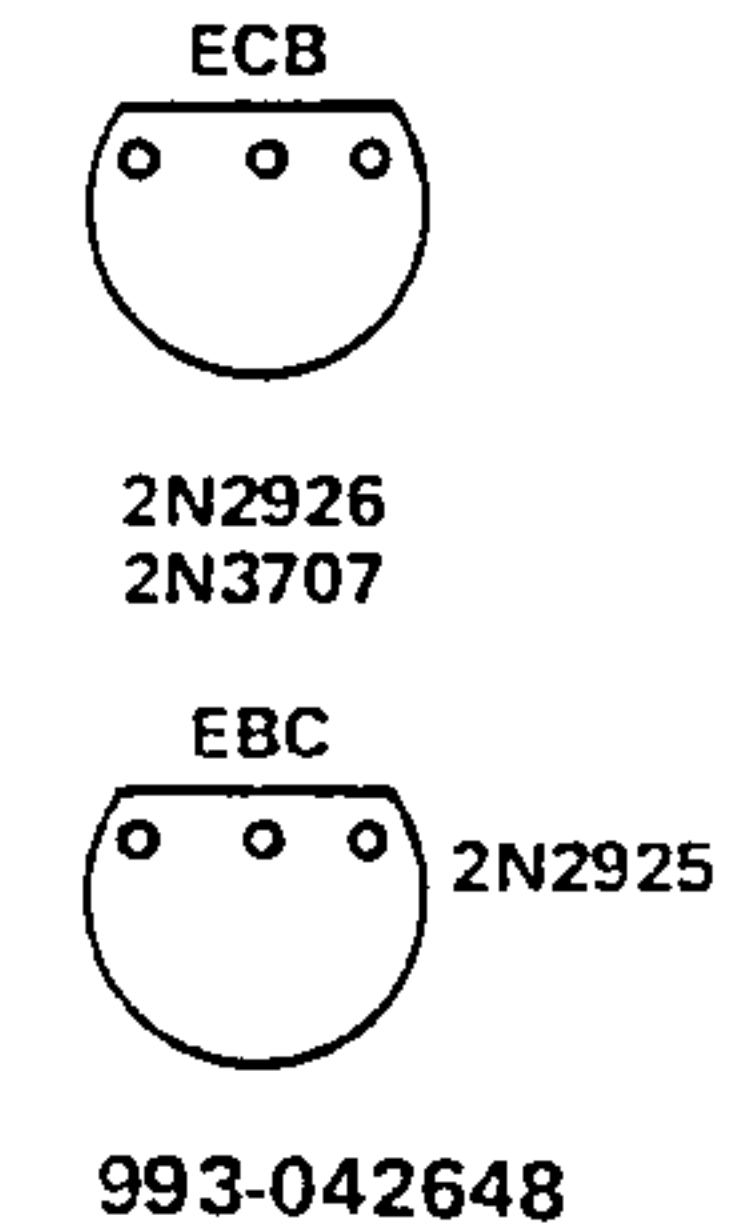

effect of which is similar to that of reverberation of sound. If a small amount of "echo signal" is mixed with a larger amount of "direct signal" (REVERBERATION Control set slightly clockwise), the effect of a typical concert hall is obtained. If the echo signal only is passed (REVERBERATION Control set fully clockwise), an exaggerated echo suggesting a cave is obtained. The relative amount of echo signal and direct signal can be continuously changed from 100 percent direct signal to 100 percent echo signal.

When a static signal is applied to the input of the 905, the output will also be static. There will be no sensation of echo. Rather, the 905 will perform in this application like a formant filter, strongly coloring the timbre of any signal with appreciable harmonic content.

**FIGURE 14 REVERBERATION UNIT MODEL 905**

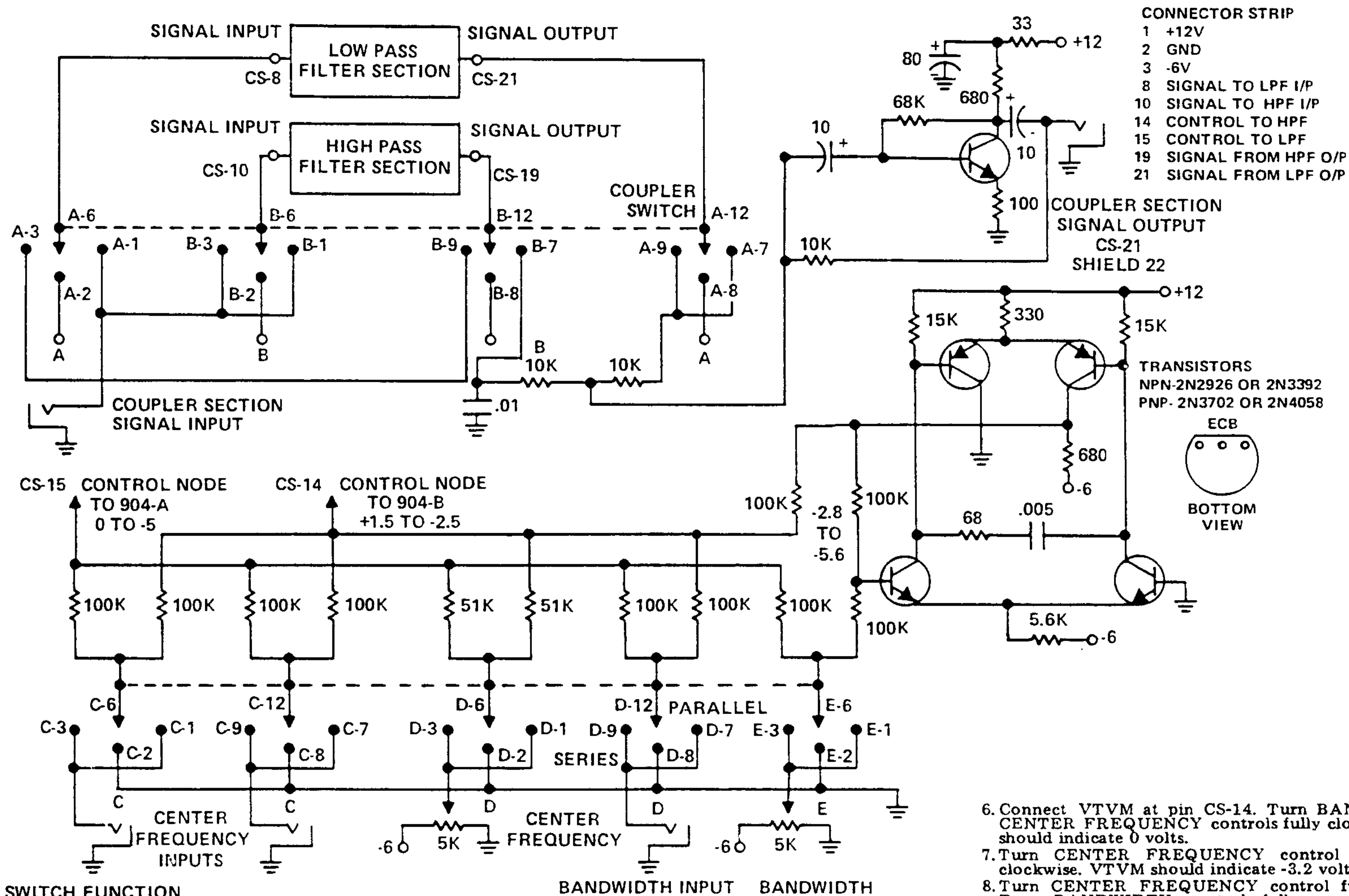

**SWITCH FUNCTION**  
 POSITION THREE ON FRONT PANEL -  
 SERIES (BAND PASS)  
 POSITION TWO ON FRONT PANEL -  
 LOW PASS - HIGH PASS  
 POSITION ONE ON FRONT PANEL -  
 PARALLEL (BAND REJECT)

**904C VOLTAGE CONTROLLED FILTER COUPLER  
 TEST PROCEDURE**

**NOTE:** All indications must be  $\pm 10\%$

1. Connect a 100K ohm resistor between CS-8 and CS-21 and also between CS-10 and CS-19.
2. Connect vacuum tube voltmeter (VTVM) at 680-ohm resistor in coupler section. Turn BANDWIDTH and CENTER FREQUENCY controls in full clockwise position. VTVM should indicate 0 volts.
3. Turn CENTER FREQUENCY control fully counterclockwise. VTVM should indicate +1.60 volts.
4. Turn BANDWIDTH control counterclockwise. VTVM indication should vary from +1.60 volts to +5.00 volts.
5. Turn COUPLER switch from BAND REJECT to OFF to BAND PASS. VTVM should indicate 0 volts in OFF position for all conditions. Band pass and band reject should indicate the same for all control settings.

6. Connect VTVM at pin CS-14. Turn BANDWIDTH and CENTER FREQUENCY controls fully clockwise. VTVM should indicate 0 volts.
7. Turn CENTER FREQUENCY control fully counterclockwise. VTVM should indicate -3.2 volts.
8. Turn CENTER FREQUENCY control fully clockwise. Turn BANDWIDTH control fully counterclockwise. VTVM should indicate +1.0 volt.
9. Turn CENTER FREQUENCY control fully counterclockwise. VTVM should indicate -2.6 volts.
10. Connect VTVM at CS-15. Turn BANDWIDTH and CENTER FREQUENCY control fully clockwise. Voltmeter should indicate 0 volts.
11. Turn CENTER FREQUENCY control fully counterclockwise. VTVM should indicate -3.2 volts.
12. Turn CENTER FREQUENCY control clockwise. Turn BANDWIDTH control fully counterclockwise. VTVM should indicate -1 volt.
13. Turn CENTER FREQUENCY control fully counterclockwise. VTVM should indicate -4.6 volts.
14. Connect oscillator, set at 1k 0db, to 904C SIGNAL INPUT. Connect VTVM to SIGNAL OUTPUT. DB meter should indicate -19db with COUPLER switch in BAND REJECT mode and -30db in BAND PASS mode.

FIGURE 13 VOLTAGE CONTROLLED FILTER COUPLER MODEL 904C

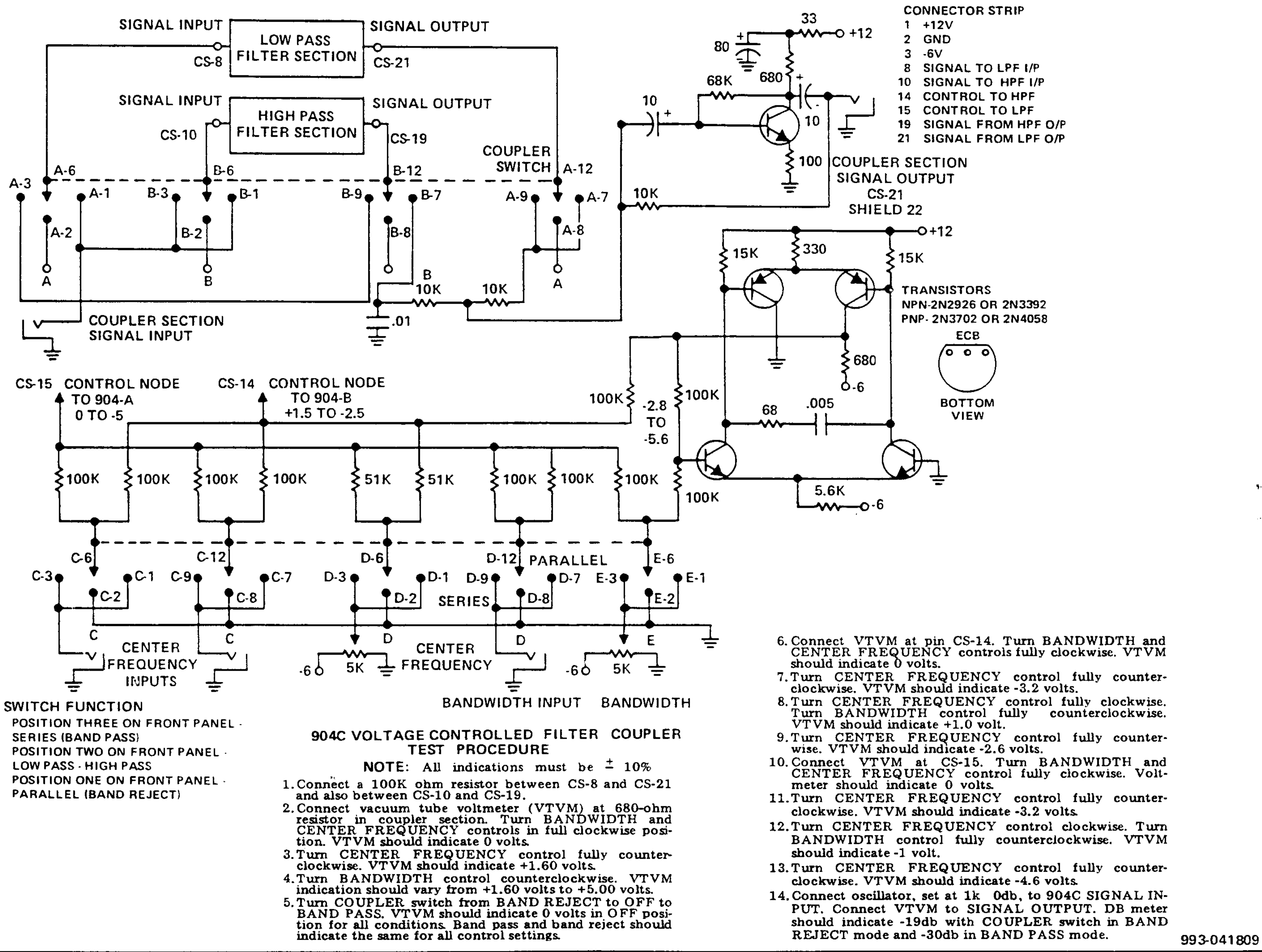
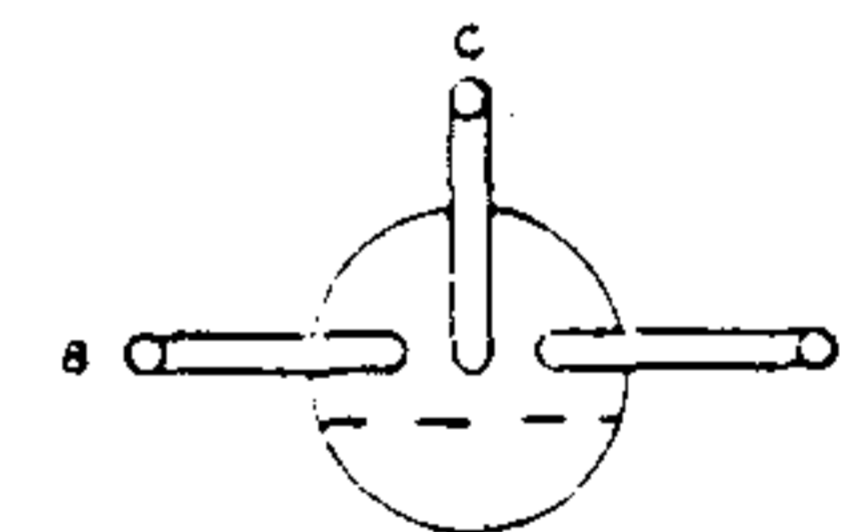
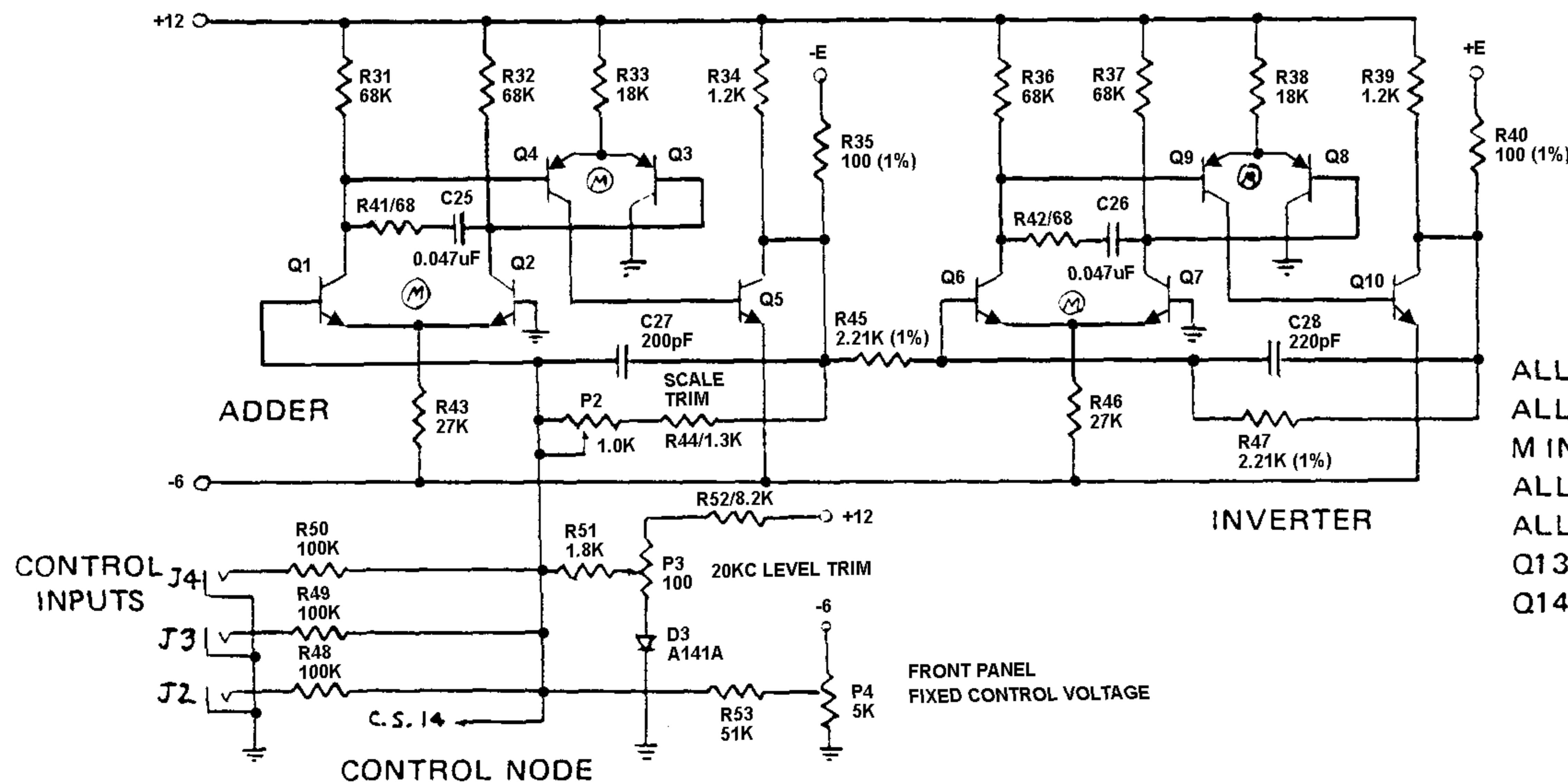
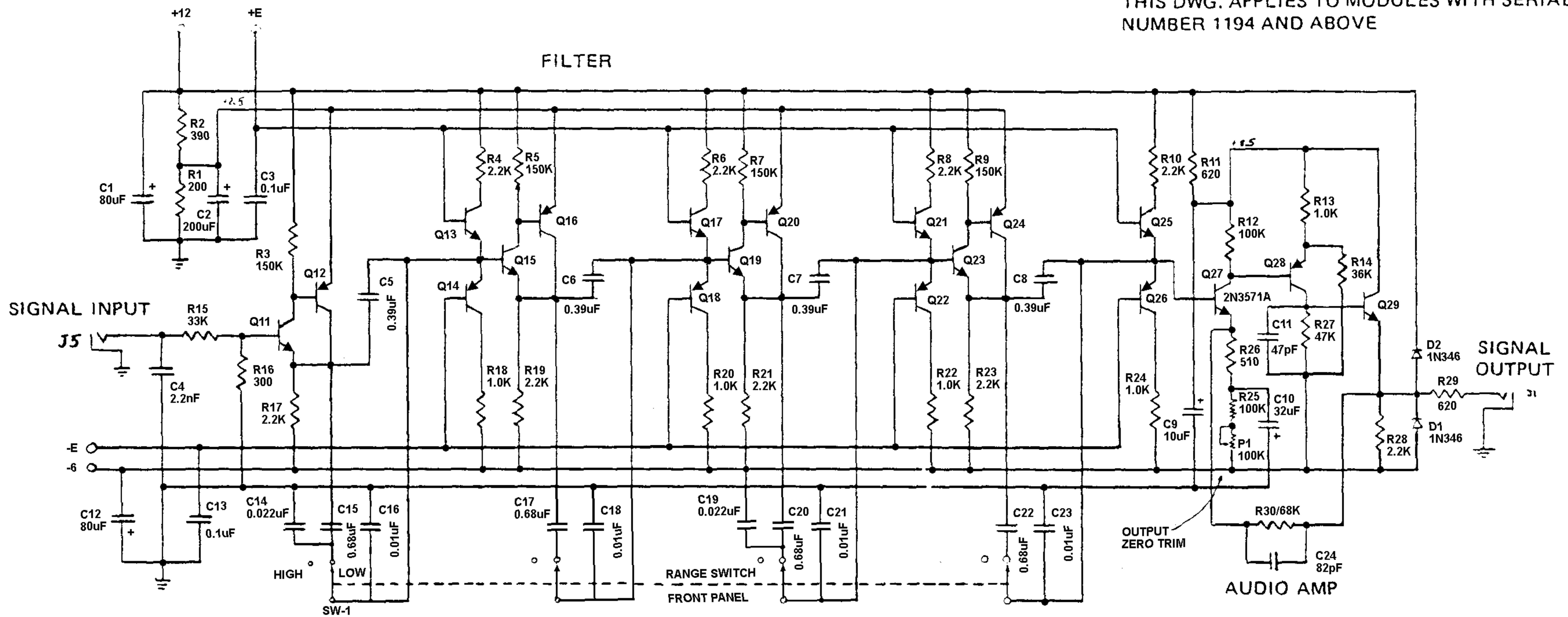

FIGURE 13 VOLTAGE CONTROLLED FILTER COUPLER MODEL 904C





TYPICAL BASE LAY-OUT FOR ALL TRANSISTORS USED IN CIRCUITRY.

- CONNECTOR STRIP
1. +12
  2. GROUND
  3. -6
  10. SIGNAL INPUT
  11. GROUND
  14. CONTROL NODE
  15. CONTROL NODE
  16. GROUND
  19. SIGNAL OUTPUT
  20. GROUND

ALL NPN TRANSISTORS 2N3392 EXCEPT Q27  
 ALL PNP TRANSISTORS 2N4058  
 M INDICATES MATCHED PAIR  
 ALL RESISTORS 1/2 WATT 5% CARBON } UNLESS OTHERWISE MARKED  
 ALL CAPACITORS IN UF  
 Q13, 17, 21, 25 ARE A MATCHED SET  
 Q14, 18, 22, 26 ARE A MATCHED SET

MOOG MUSIC INC.

SCHEMATIC, 904B, VOLTAGE CONTROLLED HIGH PASS FILTER

997-041807

1118

FIGURE 12 VOLTAGE CONTROLLED HIGH PASS FILTER MODEL 904B

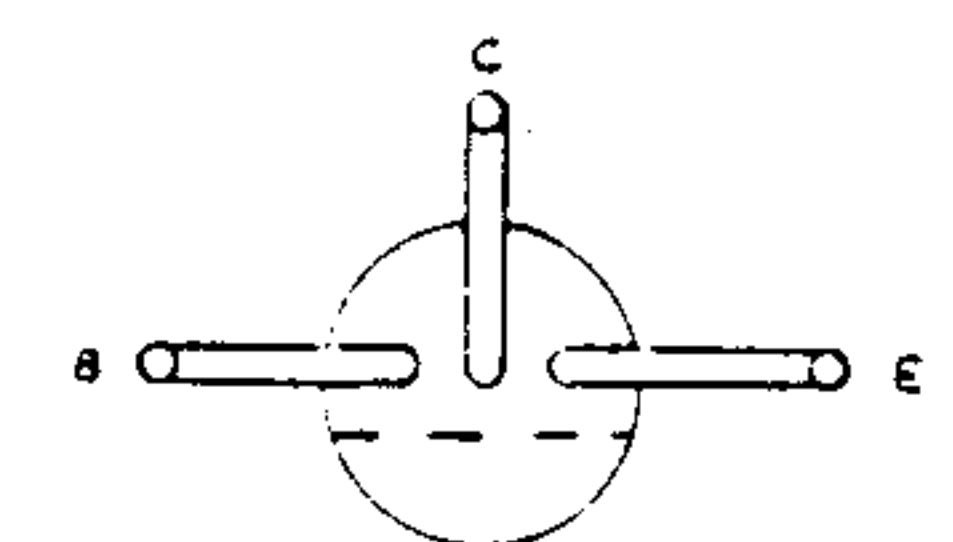
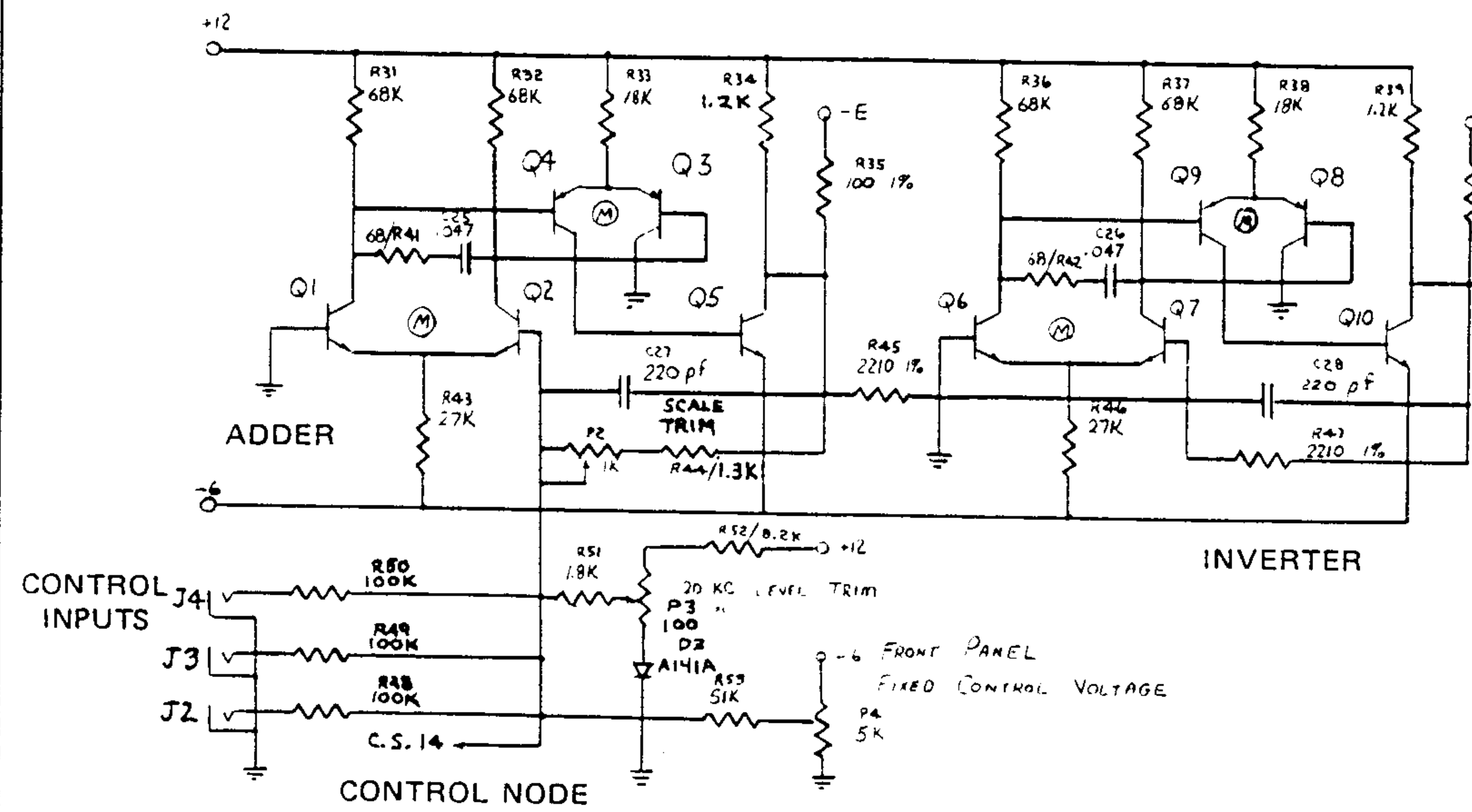
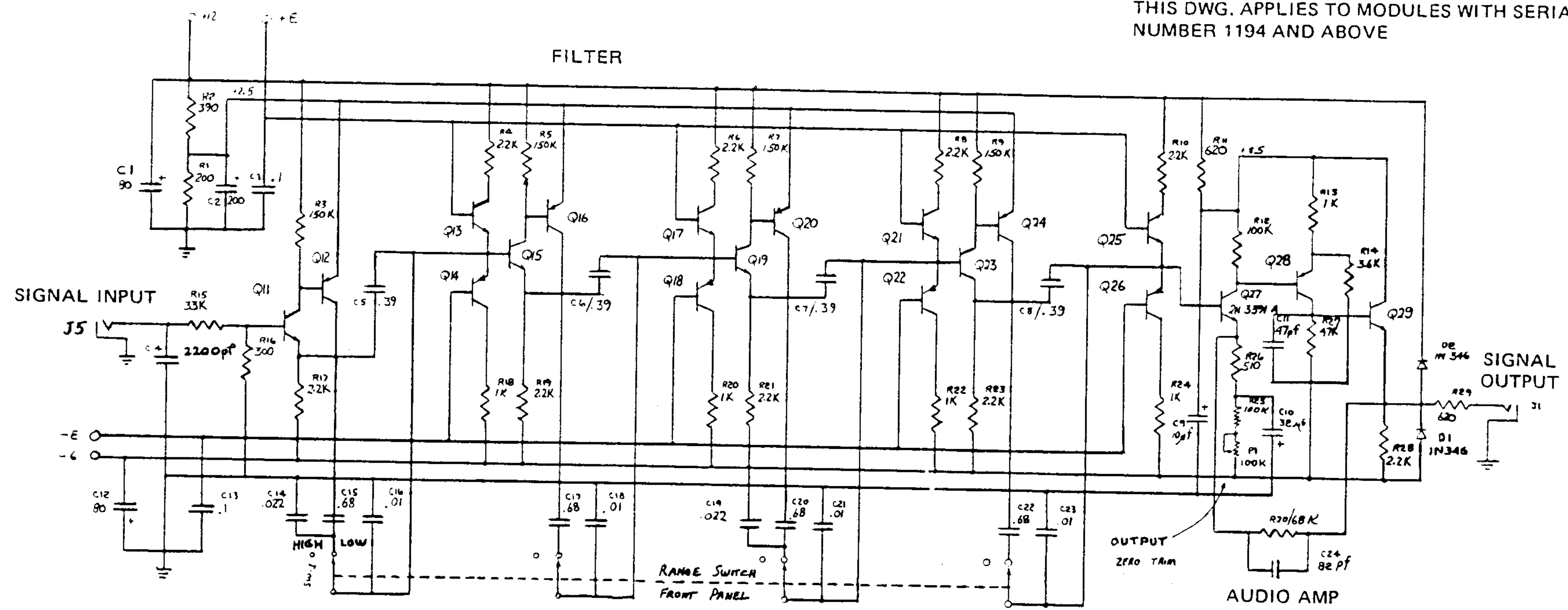

TYPICAL BASE LAY-OUT FOR ALL TRANSISTORS USED IN CIRCUITRY.

- CONNECTOR STRIP
- 1. +12
  - 2. GROUND
  - 3. -6
  - 10. SIGNAL INPUT
  - 11. GROUND
  - 14. CONTROL NODE
  - 15. CONTROL NODE
  - 16. GROUND
  - 19. SIGNAL OUTPUT
  - 20. GROUND

ALL NPN TRANSISTORS 2N3392 EXCEPT Q27  
 ALL PNP TRANSISTORS 2N4058  
 M INDICATES MATCHED PAIR  
 ALL RESISTORS 1/2 WATT 5% CARBON } UNLESS OTHERWISE MARKED  
 ALL CAPACITORS IN UF  
 Q13, 17, 21, 25 ARE A MATCHED SET  
 Q14, 18, 22, 26 ARE A MATCHED SET

MOOG MUSIC INC.  
 SCHEMATIC, 904B, VOLTAGE CONTROLLED HIGH PASS FILTER  
 997-041807

FIGURE 12 VOLTAGE CONTROLLED HIGH PASS FILTER MODEL 904B

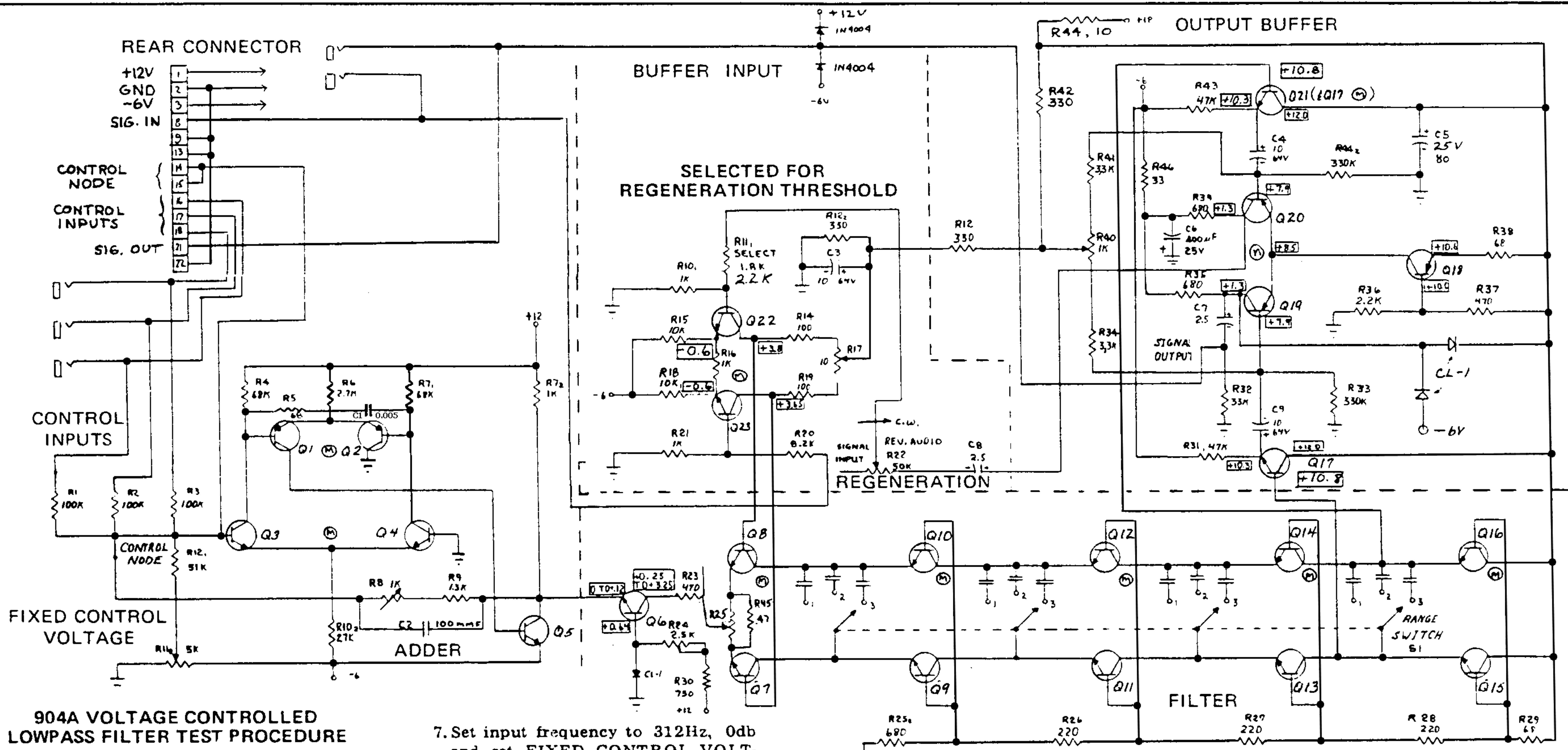

**904A VOLTAGE CONTROLLED LOWPASS FILTER TEST PROCEDURE**

1. Set wirewound trimpots R17 and R25 to mid-position.
2. Set FIXED CONTROL VOLTAGE to "6", FREQUENCY RANGE to "2" and REGENERATION to "0".
3. Using a dc voltmeter, check the voltages at R35 and R39. Both levels will be approximately 1.0 volts. Adjust R40 (zero trimpot on filter board) for approximately the same voltage at R35 and R39.
4. Connect DC VOLTMETER across R23 (470 ohms) and adjust 2.0 volt LEVEL trimpot (R24) for 2.0 volts. Disconnect DC VOLTMETER after adjusting.
5. Apply a 20kHz 0db sinewave to the SIGNAL INPUT jack.
6. Signal output should be  $-8 \pm 2$ db, 20kHz.

7. Set input frequency to 312Hz, 0db and set FIXED CONTROL VOLTAGE to "0".
8. Adjust SCALING trimpot (R8) for -8db.
9. Remove input signal, set REGENERATION to "8", RANGE to "2" and FIXED CONTROL VOLTAGE to "0".
10. Connect a Decade Resistance Box across R11 and determine what shunt resistance is required to establish the threshold of regeneration. Permanently install the proper shunt resistor (approximately 2.2K) and set REGENERATION control between 7 and 8.
11. With a zero db sinewave at the SIGNAL INPUT, REGENERATION at "0", no external input control voltage and the FIXED CONTROL VOLTAGE at "0", check the FREQUENCY RANGE switch for compliance with following:

RANGE	-3db Point (approximately)
1	60 to 80 Hz
2	260 to 340 Hz
3	1.0 to 1.3kHz

12. Check to see that the cutoff frequency decreases one octave for each one volt decrease in control voltage. Use RANGE "2" and FIXED CONTROL VOLTAGE of "0". Adjust generator frequency so that output is at -3db (260 to 340Hz). Set FIXED CONTROL VOLTAGE at -5.5 volts and apply +5 volts to one of the CONTROL INPUTS. The output should be  $-3 \pm 2$ db. Set FIXED CONTROL VOLTAGE at +5.5 volts and apply -6.0 volts to one of the CONTROL INPUTS. The output should be  $-3 \pm 2$ db.

**NOTES:**

1. ALL NPN TRANSISTORS: 2N3392
2. ALL PNP TRANSISTORS: 2N4058
3. (M) ⇒ MATCHED PAIR
4. RANGE CAPACITOR SIZES
  - 1 1.2 μF
  - 2 0.3 μF
  - 3 0.075 μF

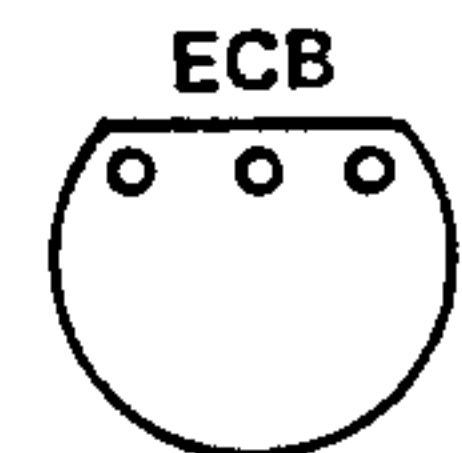

**BOTTOM VIEW**  
2N3392  
2N4058

**MOOG MUSIC INC.**  
SCHEMATIC 904A VOLTAGE CONTROLLED LOW PASS FILTER 993-041805 1149

**FIGURE 11 VOLTAGE CONTROLLED LOW PASS FILTER MODEL 904A**

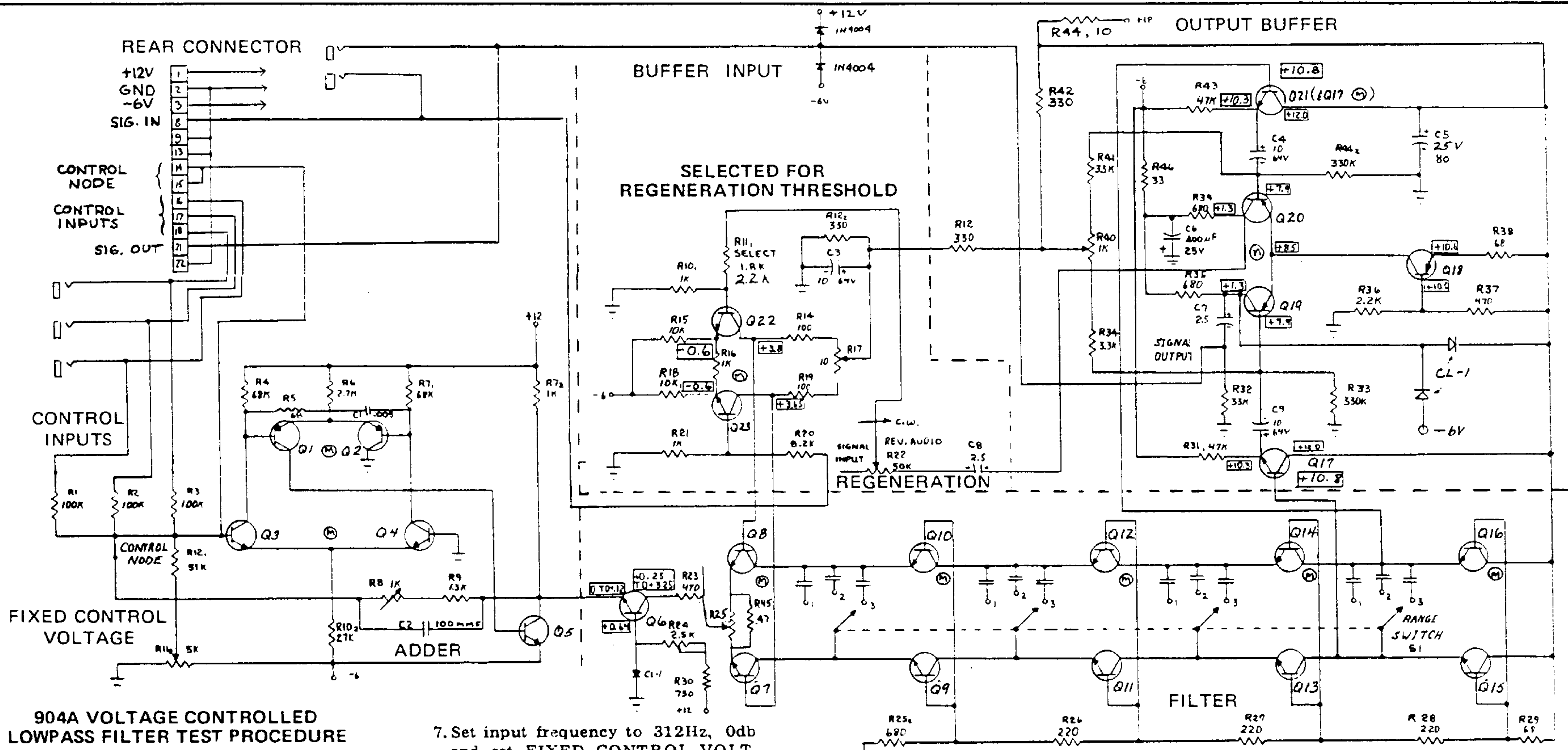

### 904A VOLTAGE CONTROLLED LOWPASS FILTER TEST PROCEDURE

1. Set wirewound trimpots R17 and R25 to mid-position.
2. Set FIXED CONTROL VOLTAGE to "6", FREQUENCY RANGE to "2" and REGENERATION to "0".
3. Using a dc voltmeter, check the voltages at R35 and R39. Both levels will be approximately 1.0 volts. Adjust R40 (zero trimpot on filter board) for approximately the same voltage at R35 and R39.
4. Connect DC VOLTMETER across R23 (470 ohms) and adjust 2.0 volt LEVEL trimpot (R24) for 2.0 volts. Disconnect DC VOLTMETER after adjusting.
5. Apply a 20kHz 0db sinewave to the SIGNAL INPUT jack.
6. Signal output should be  $-8 \pm 2$ db, 20kHz.

7. Set input frequency to 312Hz, 0db and set FIXED CONTROL VOLTAGE to "0".
8. Adjust SCALING trimpot (R8) for -8db.
9. Remove input signal, set REGENERATION to "8", RANGE to "2" and FIXED CONTROL VOLTAGE to "0".
10. Connect a Decade Resistance Box across R11 and determine what shunt resistance is required to establish the threshold of regeneration. Permanently install the proper shunt resistor (approximately 2.2K) and set REGENERATION control between 7 and 8.
11. With a zero db sinewave at the SIGNAL INPUT, REGENERATION at "0", no external input control voltage and the FIXED CONTROL VOLTAGE at "0", check the FREQUENCY RANGE switch for compliance with following:

RANGE	-3db Point (approximately)
1	60 to 80 Hz
2	260 to 340 Hz
3	1.0 to 1.3kHz

12. Check to see that the cutoff frequency decreases one octave for each one volt decrease in control voltage. Use RANGE "2" and FIXED CONTROL VOLTAGE of "0". Adjust generator frequency so that output is at -3db (260 to 340Hz). Set FIXED CONTROL VOLTAGE at -5.5 volts and apply +5 volts to one of the CONTROL INPUTS. The output should be  $-3 \pm 2$ db. Set FIXED CONTROL VOLTAGE at +5.5 volts and apply -6.0 volts to one of the CONTROL INPUTS. The output should be  $-3 \pm 2$ db.

### NOTES:

1. ALL NPN TRANSISTORS: 2N3392
2. ALL PNP TRANSISTORS: 2N4058
3. (M) ⇒ MATCHED PAIR
4. RANGE CAPACITOR SIZES
  - 1 1.2  $\mu$ F
  - 2 0.3  $\mu$ F
  - 3 0.075  $\mu$ F

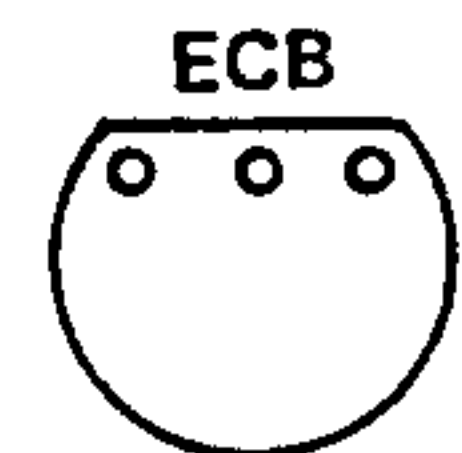

**BOTTOM VIEW**  
2N3392  
2N4058

MOOG MUSIC INC.  
SCHEMATIC 904A VOLTAGE CONTROLLED LOW PASS FILTER  
993-041805 1149

FIGURE 11 VOLTAGE CONTROLLED LOW PASS FILTER MODEL 904A

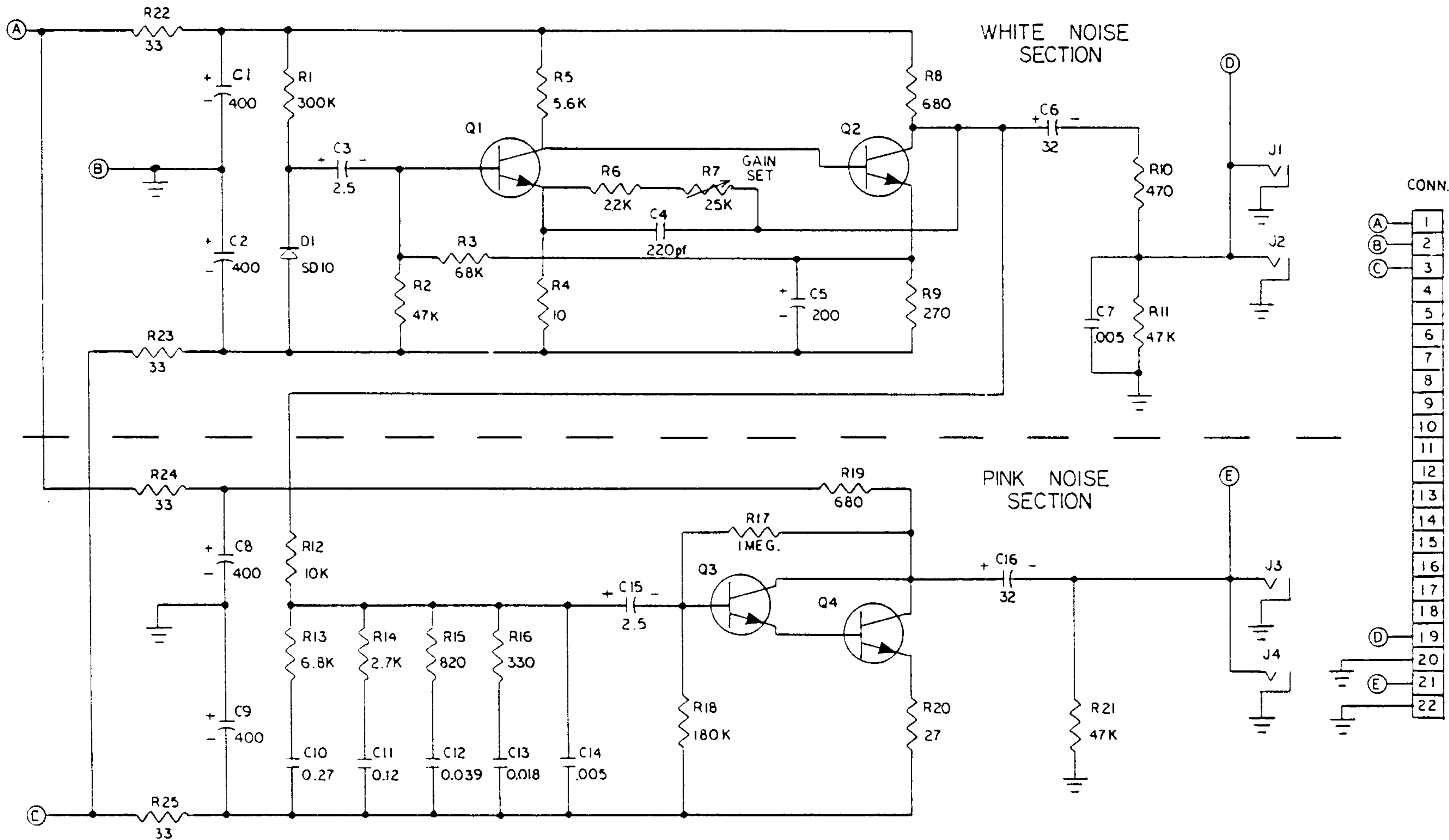

ALL TRANSISTORS MUST BE 2N3392

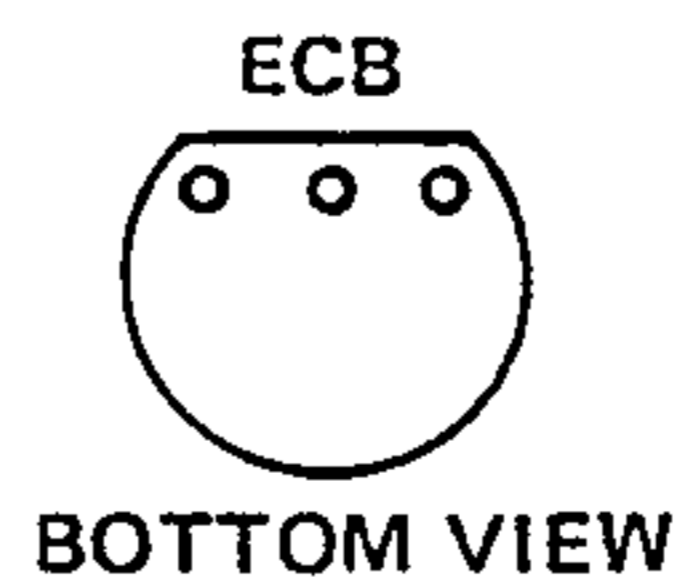

MOOG MUSIC INC.  
SCHEMATIC, 903A-RANDOM SIGNAL SOURCE  
993-041818 1335

FIGURE 10 RANDOM SIGNAL SOURCE MODEL 903A

# 902 VOLTAGE CONTROLLED AMPLIFIER TEST PROCEDURE

1. Connect dc voltmeter to TP-L (collector of Q5); low side to ground.
2. Turn FIXED CONTROL VOLTAGE pot to 6 and set CONTROL MODE switch to "EXP." DC voltage should read approximately zero.
3. Rotate FIXED CONTROL VOLTAGE pot to 0. DC voltage should read approximately +0.24V.
4. Set CONTROL MODE switch to LIN. DC voltage should read approximately +1.2V.
5. Rotate FIXED CONTROL VOLTAGE pot to 6. DC voltage should read approximately -4.8V.

### NOTE

If the above voltages are observed, the adder section (Q1 thru Q5) is operating properly.

6. With FIXED CONTROL VOLTAGE in 6 and dc voltmeter connected between one of the SIGNAL OUTPUTS jacks and ground, adjust OUTPUT BIAS trimpot for zero volts.
7. Connect dc voltmeter across positive terminals of SIGNAL OUTPUTS jacks. Connect jumper between collectors of Q8 and Q9 and adjust OUTPUT BALANCE trimpot for 0 VDC.
8. Remove jumper across collectors of Q8 and Q9 and connect across collectors of Q6 and Q7. Adjust Q8 and Q9 BALANCE trimpot for 0 VDC.
9. Remove jumper and adjust INPUT BALANCE trimpot for 0 VDC.
10. Turn FIXED CONTROL VOLTAGE pot and ascertain that there is no large offset. If necessary, repeat steps 7, 8 and 9.
11. Turn FIXED CONTROL VOLTAGE pot to 6. Apply 0db 1kHz sine wave to one of the SIGNAL INPUTS. Signal output should be approximately +5db to +7db.
12. Note the output level. Set the CONTROL MODE switch to "EXP." Adjust INPUT BIAS to obtain a level equal to that noted in the "LIN" position.

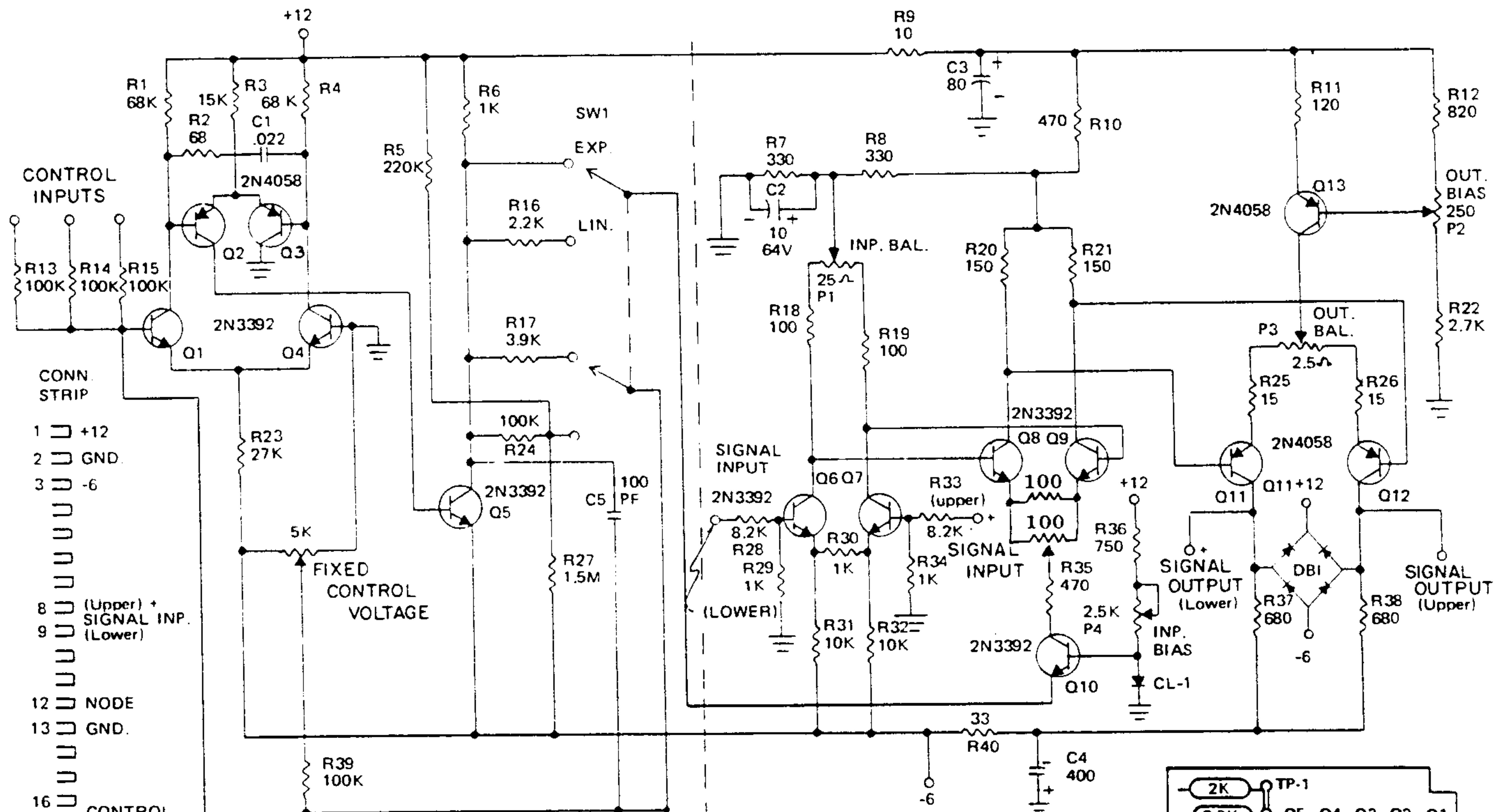

- CONN STRIP
- 1 +12
  - 2 GND.
  - 3 -6
  - 8 (Upper) + SIGNAL INP.
  - 9 (Lower)
  - 12 NODE
  - 13 GND.
  - 16 CONTROL INP.
  - 17
  - 18
  - 21 (Upper) SIGNAL OUT
  - 22 (Lower) +

PNP TRANSISTORS 2N4058  
NPN " 2N3392

2N3392 BASING DIAGRAMS

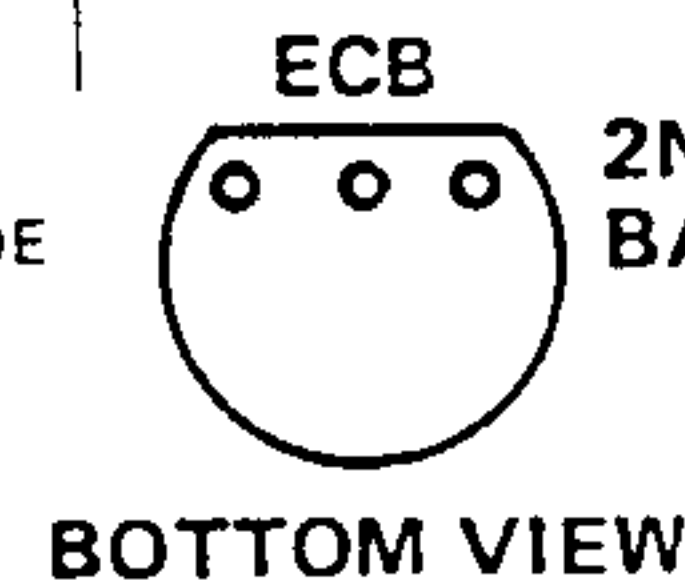

BOTTOM VIEW

13. Slowly turn FIXED CONTROL VOLTAGE pot from 6 to 0 and check for linear action in the LIN mode and exponential action in the EXP mode. At 0, signal output should be -60db maximum.
14. Turn FIXED CONTROL VOLTAGE pot to 6. With a dc bias, check each control input for proper voltage control. 0 volts should have no effect, -6 volts should cut the amplifier off completely.
15. With no signal input and FIXED CONTROL VOLTAGE set at 6, output noise should be -60db maximum.

- 1 Adjusts + output balance for exponential dc voltages with FIXED CONTROL VOLTAGE CONTROL fully counterclockwise.
- 2 Adjusts zero output offset with FIXED CONTROL VOLTAGE control fully counterclockwise.
- 3 Adjusts zero output offset with FIXED CONTROL VOLTAGE control fully clockwise.
- 4 Adjusts amplitude level balance between linear and exponential mode with FIXED CONTROL VOLTAGE control full clockwise.

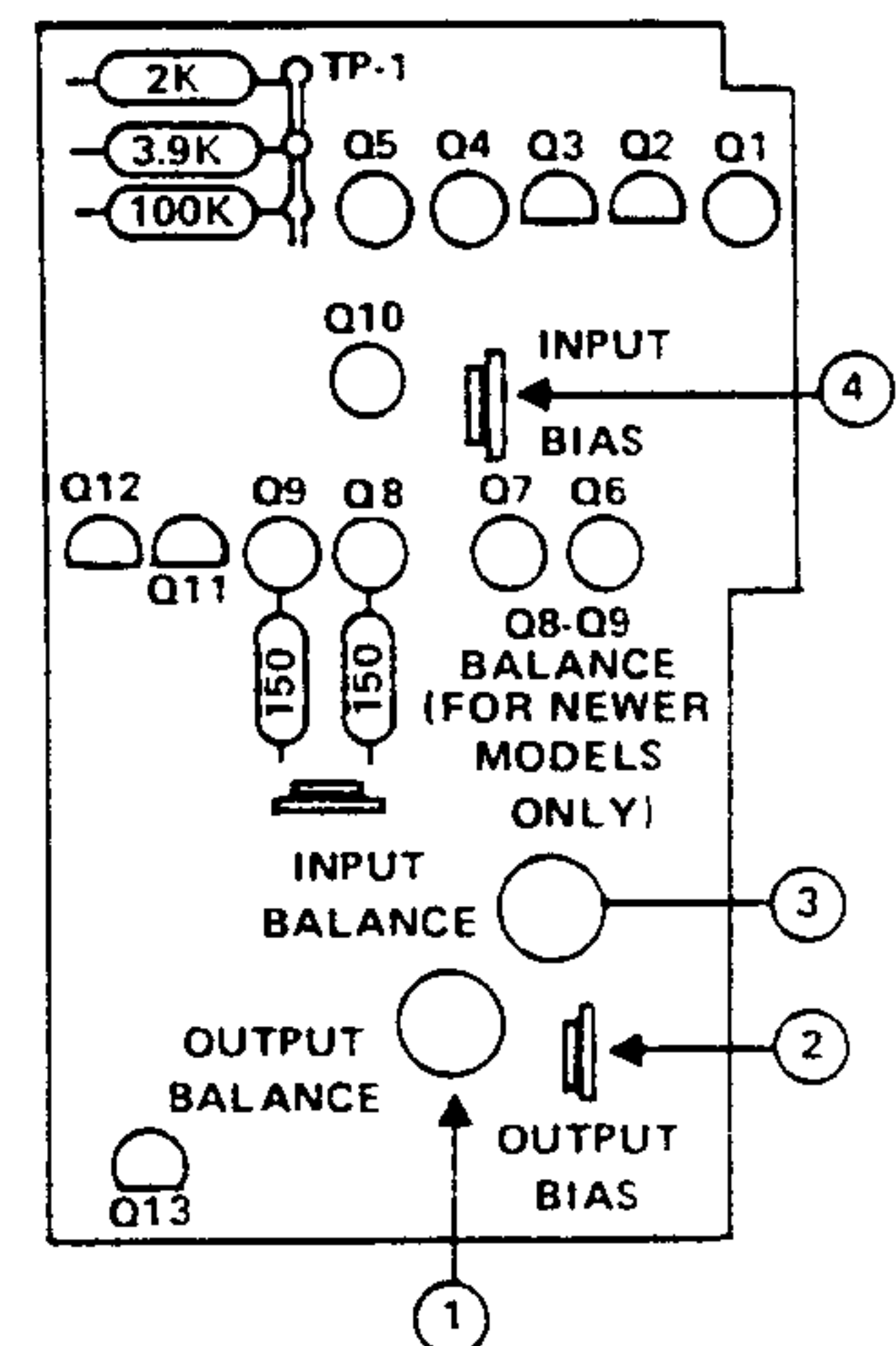

VOLTAGE CONTROLLED AMPLIFIER ALIGNMENT PROCEDURE AND ADJUSTMENT LOCATION DIAGRAM

MOOG MUSIC INC.  
SCHEMATIC, 902 VOLTAGE CONTROLLED AMPLIFIER  
993-041813

FIGURE 9 VOLTAGE CONTROLLED AMPLIFIER MODEL 902

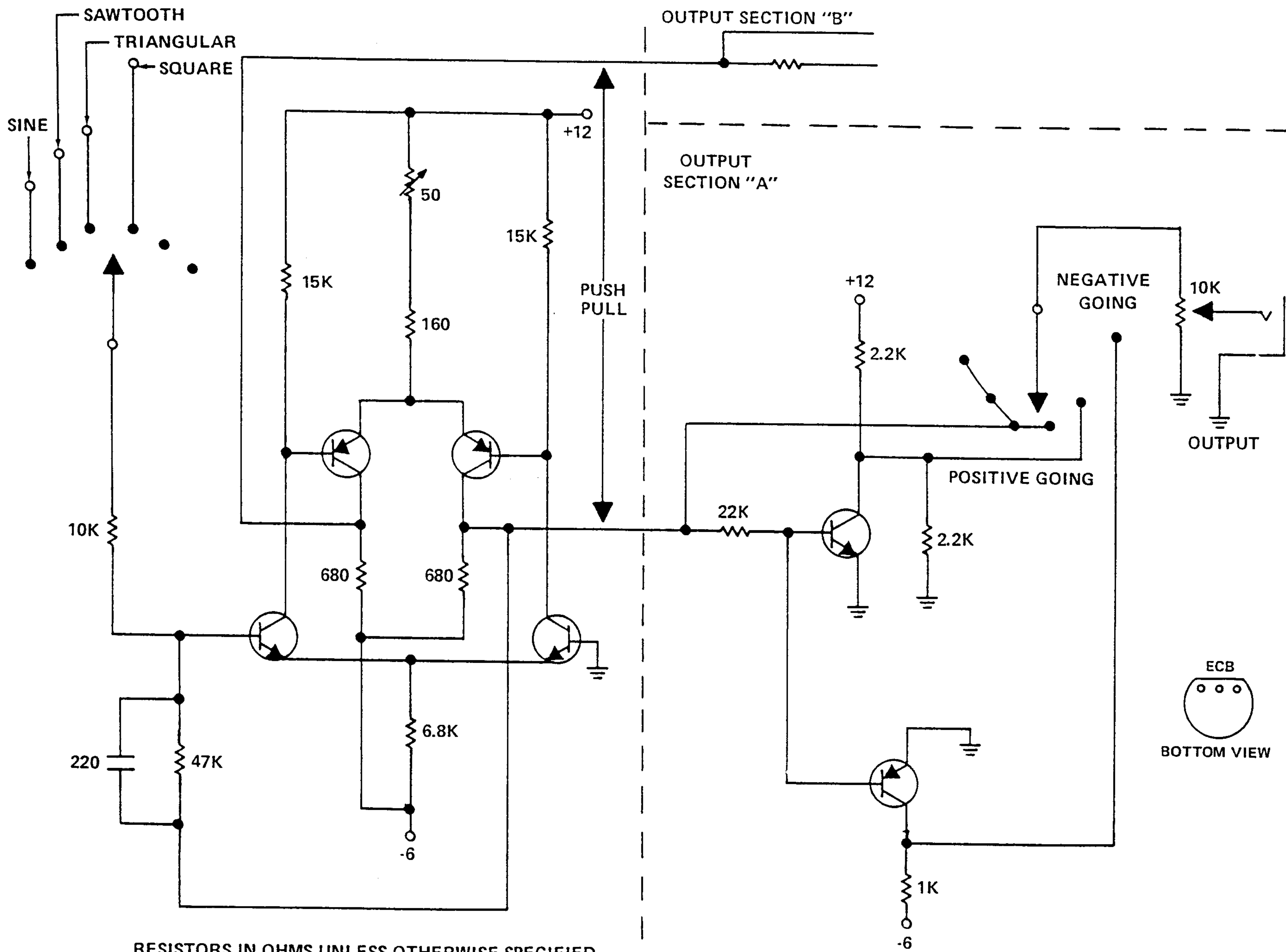

RESISTORS IN OHMS UNLESS OTHERWISE SPECIFIED

993-042647

FIGURE 8 OUTPUT STAGE MODEL 901C

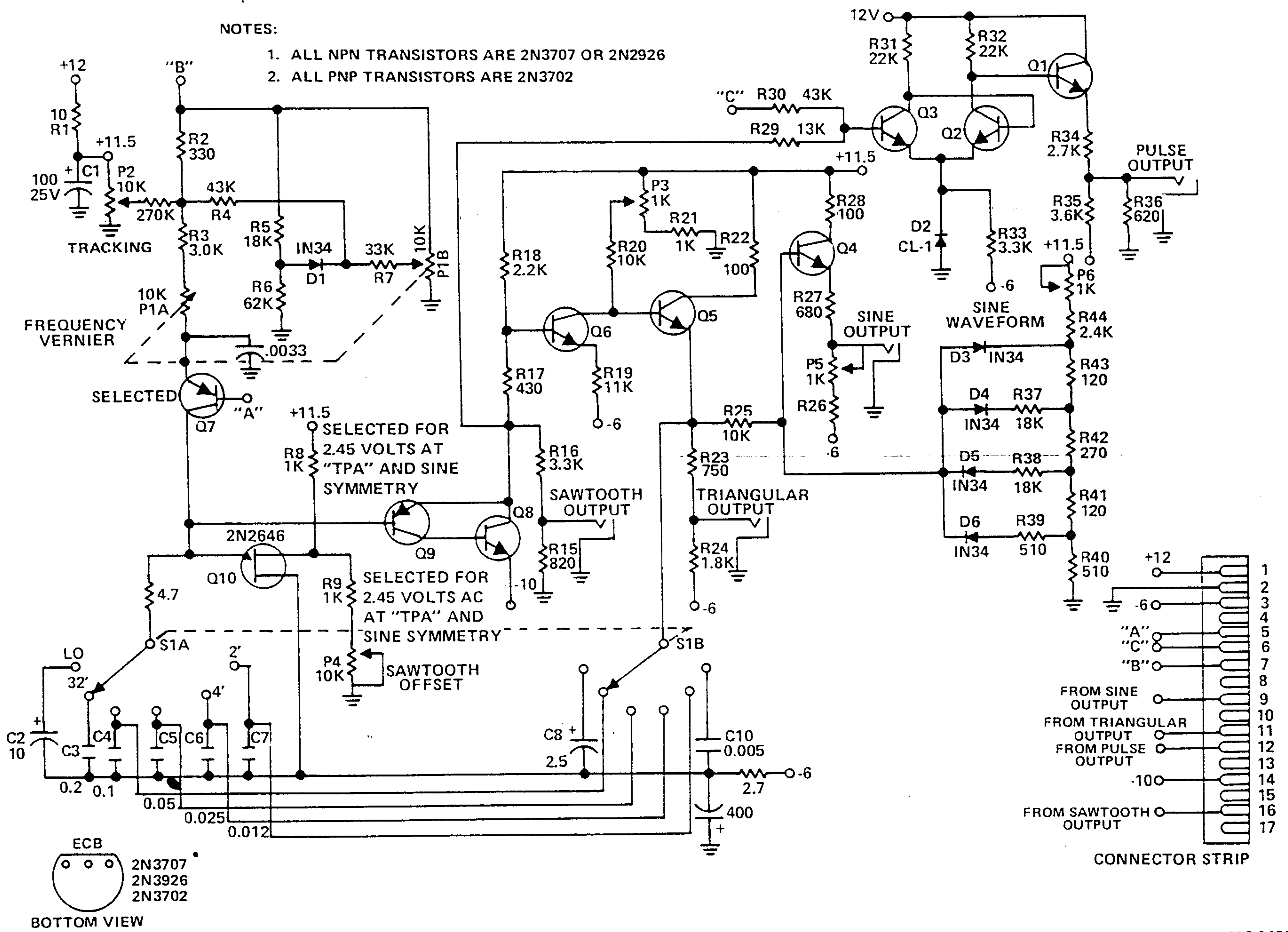

FIGURE 7 OSCILLATOR 901B



4. Turn the FIXED CONTROL VOLTAGE switch on the 901A from "5" to "0". The pitches of the oscillators will drop 5 octaves. If the frequencies of all oscillators are within 0.5 cycles of each other, that is if the beat rate between any two oscillators is no more than one every two seconds, then the tracking is satisfactory. If the beat rate between any two oscillators is greater than one every two seconds, then the tracking of the oscillator bank should be re-adjusted.

#### D. RETRACKING OF 901B OSCILLATORS WITH SERIAL NUMBERS UNDER 1912

##### NOTE

The tracking between oscillators in a single bank, that is, the accuracy with which they remain in tune with each other as the voltage to the control inputs of the bank is changed, can be adjusted by trimming the track resistors in the oscillators themselves. Insertion of a tracking resistor has the effect of lowering the oscillator frequency by a given number of cycles, regardless of the magnitude of the control voltage. The smaller the tracking resistor, the more the oscillator frequency will be lowered. The fact that a given tracking resistor will lower the frequency of an oscillator by a given number of cycles means that the tracking error (out-of-tuneness) between two oscillators will be most noticeable in the lower part of the frequency range, where a small arithmetic frequency difference corresponds to a comparatively large frequency ratio (musical interval).

To track the oscillator follow these steps:

1. Remove old tracking resistor R1.
2. Install oscillators in their enclosure and install the 901A Oscillator Controller. Apply power and allow 10 minute warm up period.
3. Set the frequency RANGE switch to 4' and the frequency VERNIER control to 7. Set FIXED CONTROL VOLTAGE controls on 901A Oscillator Controller to a total of +5 volts.
4. Mix oscillator sawtooth outputs and listen to this mixture. Trim frequency VERNIER controls on oscillators so all oscillators are producing the same frequency.

5. Reduce the FIXED CONTROL VOLTAGE controls on the oscillator so that the total is 0. The oscillator frequencies will, of course, be lowered five octaves, and may be out of tune with one another. Pick oscillator which is producing the lowest frequency. This oscillator is the "reference oscillator", and will not require a tracking resistor. Connect a resistance substitution box as the tracking resistor to each of the other oscillators in turn. Find resistors that bring the oscillators in tune with reference oscillator. (Tracking resistors typically range from 330K to 3.3 megohm). Finally, permanently install the resistance values determined by the substitution box selection.

#### E. RETRACKING OF 901B OSCILLATORS WITH INTERNAL TRACKING TRIMMER: (SERIAL NUMBERS OVER 1912)

1. Follow steps 2 thru 5 in paragraph D.
2. Pick any oscillator as the reference oscillator. Adjust tracking trimmer (P2) of the other oscillators, one at a time, until the entire bank is in tune. Use a long blade aligning screwdriver for this operation.
3. Repeat entire procedure once or twice, or until perfect tracking is obtained.

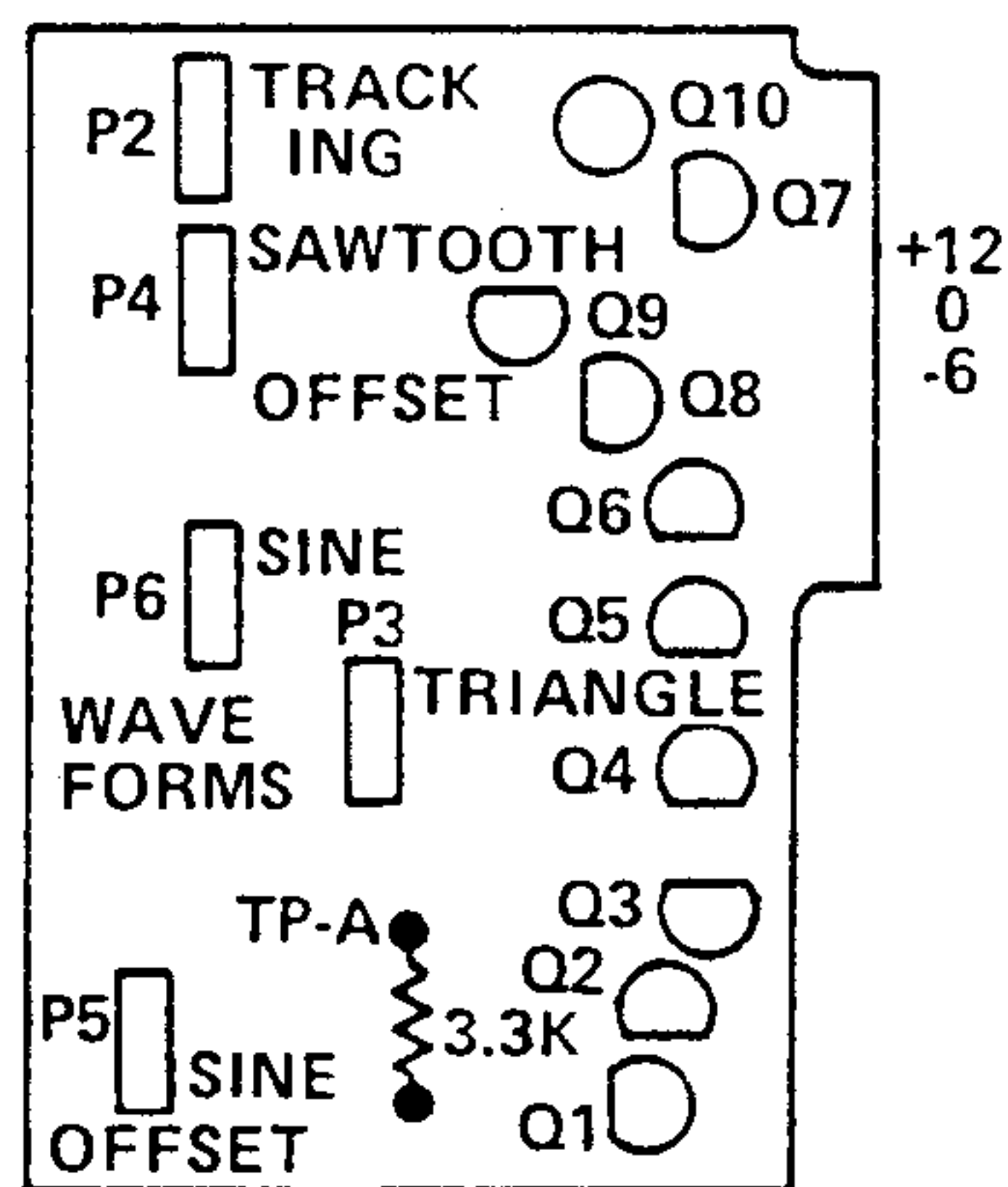

ADJUSTMENT LOCATION DIAGRAM

## 901B OSCILLATOR

### A. ADJUSTMENT PROCEDURE

1. Set front panel controls as follows:

FREQUENCY RANGE:	8'
FREQUENCY VERNIER:	10
FIXED CONTROL VOLTAGE SWITCH:	+2
FIXED CONTROL VOLTAGE POTENTIOMETER	0

2. Observe sawtooth waveform at test point "A" using a dc voltmeter and oscilloscope. DC content should be 0 volts; AC content should be approximately 2.45 volts RMS. Adjust sawtooth offset (P4) for 0 volts dc at test point "A".

#### NOTE

If unable to adjust, substitute a new 2N2646 (Q10).

3. Check triangular output as in step 2. DC should be 0-50 mv, ac approximately 650 mv RMS. Adjust triangle waveform trimpot (P3) for minimum glitch and best waveform symmetry. If a non-symmetrical waveform still exists, advance tracking pot (P2) and readjust triangle waveform (P3). If symmetry is still not possible, R8 and R9 may have to be changed. After final adjustment, the following conditions should exist:

Sawtooth output: 0.50 volts ac (-0.05 to +0.05 volts dc)

Sine output: 0.50 volts ac (0 to 0.1 volts dc)

Triangle output: 0.65 volts ac (0 to -0.05 volts dc)

Pulse output (with pulse width control clockwise): 1.2 volts ac (0 to -0.1 volts dc)

4. Check pulse output. DC should be 0-100 mv; AC should be approximately 1.2 volts RMS (50% duty cycle).

5. Check sine output. DC should be 0-100 mv; AC should be approximately 500 mv RMS. Adjust sine waveform (P6) for symmetry. Adjust SINE OFFSET (P5) for zero volts dc.

### B. TRACKING PROCEDURE FOR 901B OSCILLATOR

#### NOTE

All revised 901B Oscillator printed circuit cards (91-079) have tracking pots (P2).

1. Slide oscillator out with power cord connected and allow 30-minute warm-up period.

2. Set frequency RANGE switch at 4 ft. on each oscillator.

3. Set frequency VERNIER control at seven on each oscillator.

4. On the 901A Oscillator Controller, set FIXED CONTROL VOLTAGE switch on zero and oscillator frequency VERNIER control on zero.

5. Strike highest note with a keyboard controller.

6. Using sawtooth output adjust frequency VERNIER on oscillators one and two so that oscillators are synchronized. Repeat this procedure for oscillators two and three. (On systems that have only two oscillators, omit last procedure.)

7. Strike lowest note with keyboard controller.

8. Listen to sawtooth outputs, one at a time, on oscillators one, two and three. Determine which one of the three is the lowest frequency.

#### NOTE

The lowest in frequency oscillator is the one which the other one or two oscillators in the bank will be tuned to.

9. Slide oscillator back in and secure. No other internal adjustments to be made.

#### NOTE

This oscillator will be referred to as the reference oscillator for the remainder of the tracking procedure.

10. Select one of the two remaining oscillators in the bank and listen to it (sawtooth) along with the reference oscillator. Adjust tracking pot (P2) counter-clockwise until oscillator is synchronized with the reference oscillator. Strike the highest note. Oscillator should still be synchronized at the high end. If not, adjust frequency VERNIER on test oscillator until synchronized. Strike the lowest note and re-adjust, if necessary, tracking pot (P2) on test oscillator.

11. Repeat tracking procedure for remaining oscillator in the bank if system has a third oscillator.

12. Repeat tracking procedure for each oscillator bank in the system.

### C. TRACKING PROCEDURE FOR 901B OSCILLATORS

#### NOTE

Tracking is the tuning accuracy between two or more 901B Oscillators which are being controlled by a single 901A, that is, maintained when the control voltage applied to the 901A is changed. To check the 901B Oscillators in a given bank, perform the following steps.

1. Set all 901B Oscillators front panel controls as follows:

RANGE: 4'

VERNIER: 7' (approximately)

2. Set the 901A Oscillator, which controls the oscillator bank front panel controls as follows:

FIXED CONTROL VOLTAGE SWITCH: 5

FIXED CONTROL VOLTAGE Control: 0

Width of PULSE WAVEFORM: Full  
Clockwise

Also, disconnect all externally applied control voltages. Turn off all control voltage switches and extend control voltage programmers.

3. Mix the sawtooth outputs of all the 901B Oscillators and listen to the mixture. Now readjust the frequency VERNIER controls on each oscillator in turn, so that in the end all oscillators are producing the same pitch.

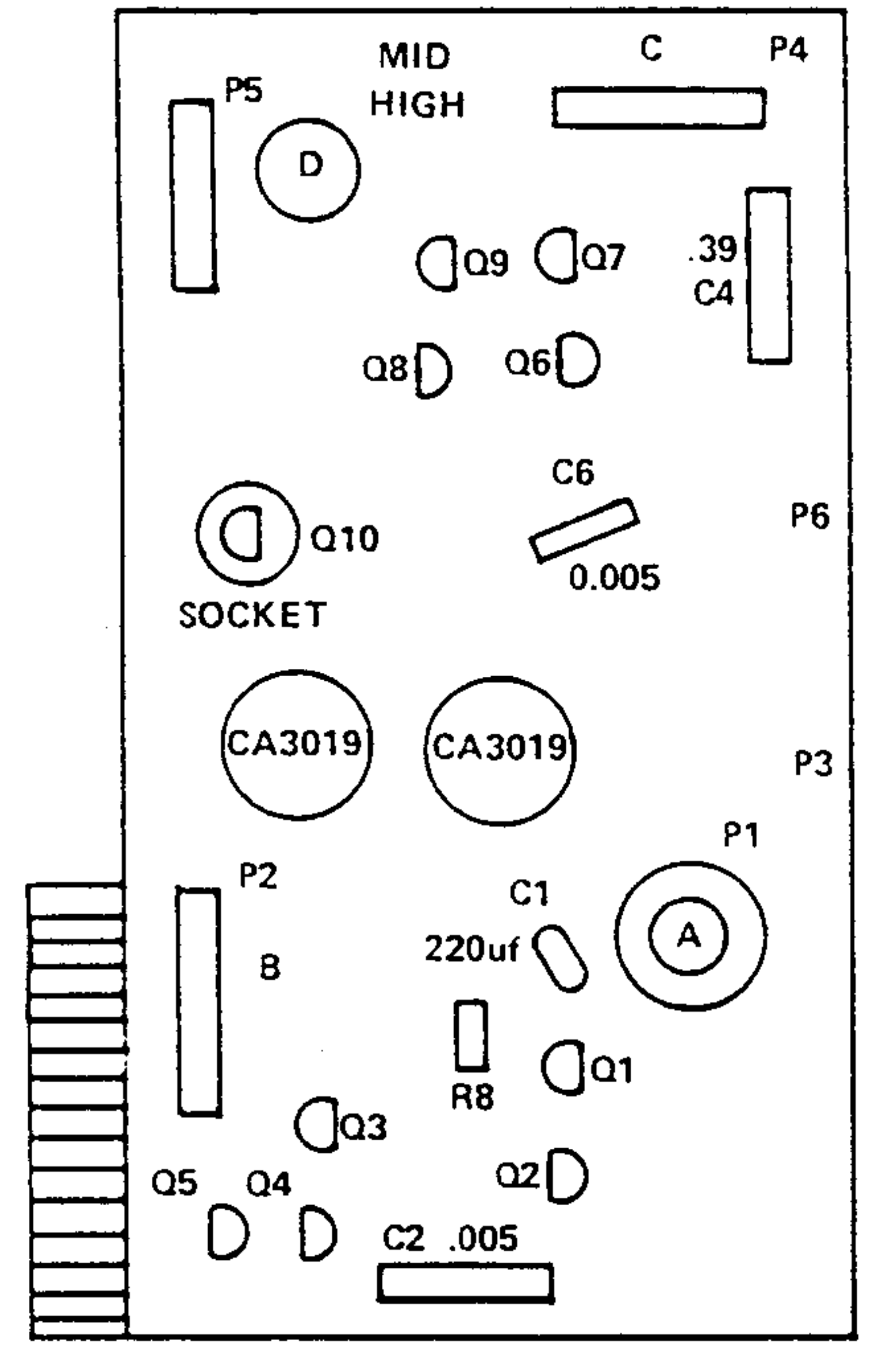
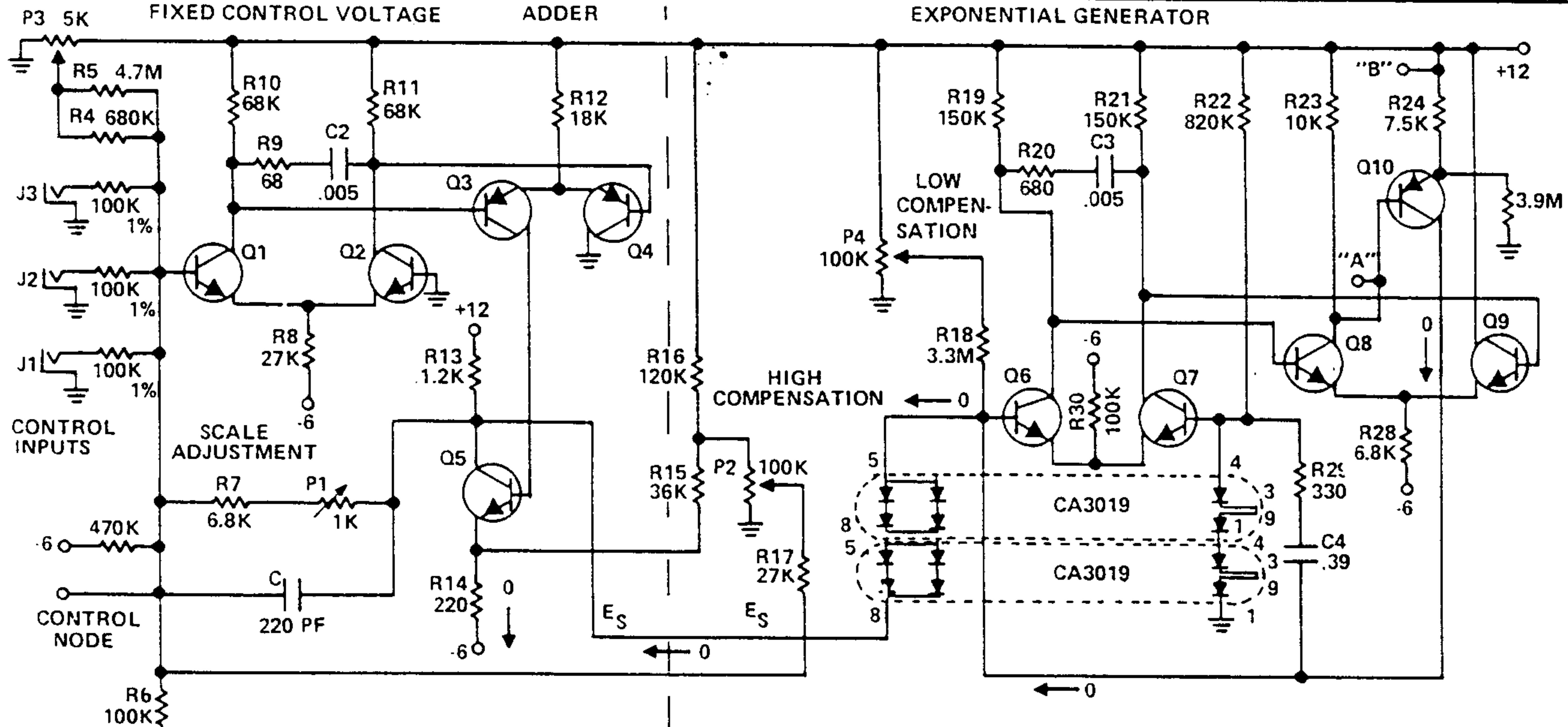

901A OSCILLATOR ADJUSTMENT LOCATIONS

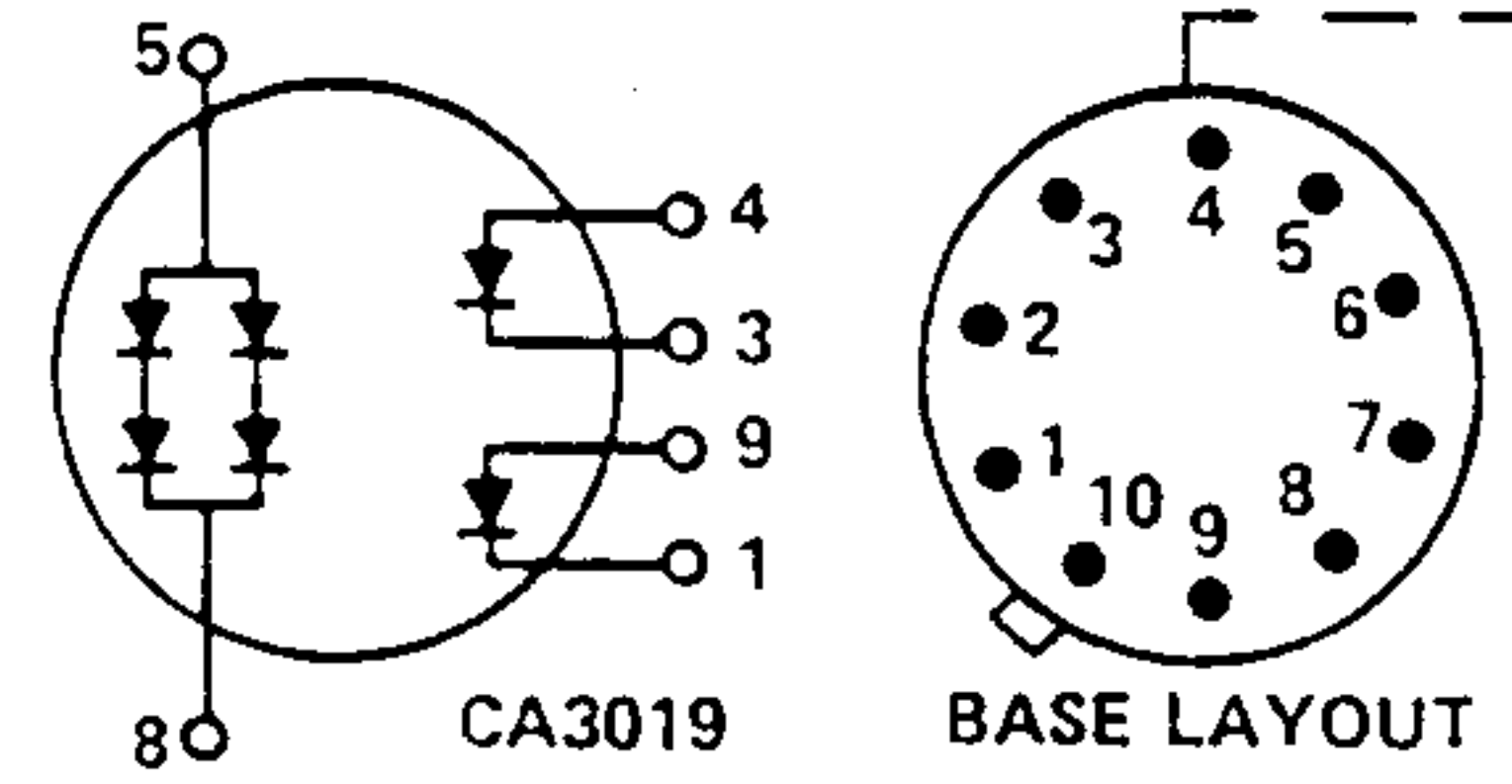
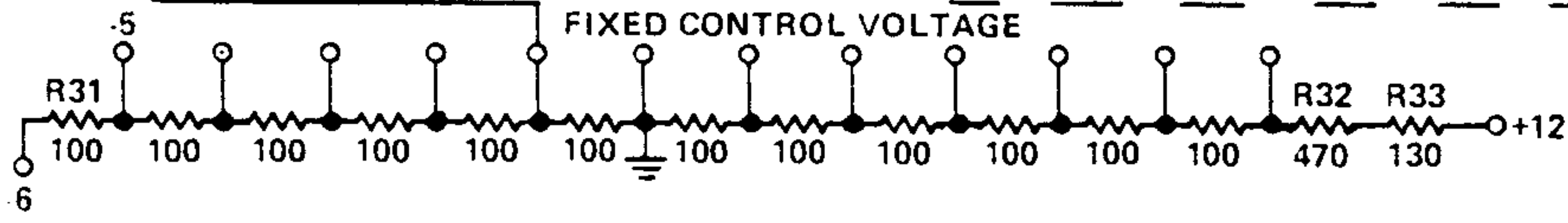

TABLE 1

	EMITTER	COLLECTOR	BASE
Q1	-0.54	+5.57	0.004
Q2	-0.54	+5.55	0.00
Q3	6.14	-3.0	5.57
Q4	6.14	0	5.55
Q5	-3.64	-.04	-3.0
Q6	+1.93	+5.87	2.43
Q7	+1.93	+5.87	2.43
Q8	5.35	11.16	5.87
Q9	5.35	12.00	5.87
Q10	11.71	2.43	11.16

\*SEE PARAGRAPH B.2

NOTES:

1. ALL NPN TRANSISTORS ARE 2N3391A OR 2N3392
2. ALL PNP TRANSISTORS ARE 2N4058

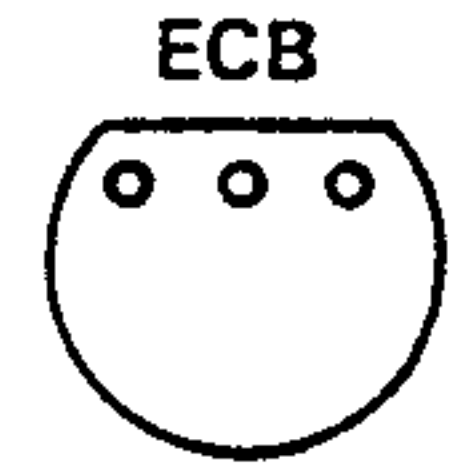

2N3392  
2N3391A  
2N4058  
BOTTOM VIEW

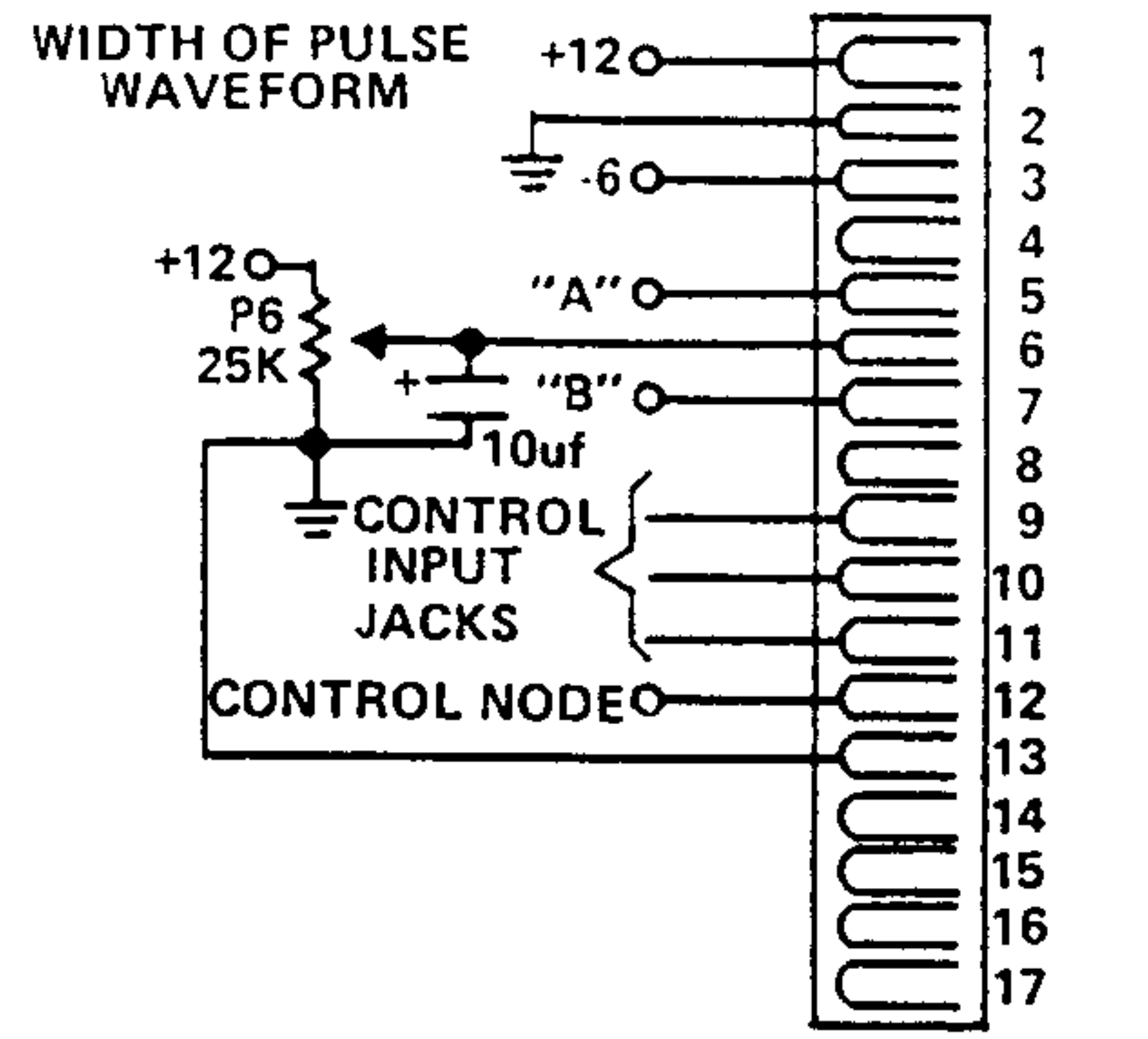

# 901A OSCILLATOR CONTROLLER

## A. TUNING PROCEDURE

The 901A adjustments should be set only after the 901B oscillators have been adjusted to track properly as described for the 901B and the 901A has been allowed to run in the cabinet with the 901B's for at least ten minutes. The instruments should be at room temperature.

1. Set the two FIXED CONTROL VOLTAGE controls on the 901A panel to "0".

2. Connect an accurately calibrated voltage source, which is stable to within  $\pm 0.1\%$ , to one of the control inputs of the 901A. For instance, the pitch control voltage of a 950 Keyboard Controller may be used as the voltage source. The voltage source should be monitored with a digital voltmeter of accuracy at least 0.1%. If a 950 is used, its SCALE control should be set so there is exactly one volt difference between octaves. Keyboards produced after 1968 are calibrated so that at room temperature, there is a one volt difference between octaves when the SCALE control is set on "5".

3. Change the voltage of the source alternately from 2.00 to 3.00 volts. (On the 950 Keyboard, set the RANGE control to "5" and play the keys corresponding to middle C and an octave above.) The output frequency of an oscillator being controlled by the 901A should change exactly one octave (a frequency ratio of 2:1). The accuracy of the one octave change can be measured by one of the three following methods.

- If you have a trained ear and "perfect pitch," you can hear directly how accurate the octave is.
- Using a frequency counter, you can measure the two frequencies. They should be exactly a factor of two apart. For measuring low frequencies, use a 10 second counter gate time.
- Listen simultaneously to a subtle test oscillator whose 901A is being adjusted. You can easily hear the beat, or difference in frequency. Set the test oscillator so that it is the same frequency as the higher note of the interval in question (i.e. no beating is heard). If the lower note of the interval produces no (or very slow) beating with the test oscillator, then the interval is an accurate octave. To set the size of the octave in this step, adjust the SCALE ADJUSTMENT (P1). With each resetting of the

SCALE ADJUSTMENT, the test oscillator will have to be reset to zero beat with the higher note.

4. Change the voltage of the source alternately from 0.50 to 1.50 volts. (On the 950 Keyboard, play the keys corresponding to the lowest F Sharp and the F Sharp an octave above it.) Set the LOW COMPENSATION ADJUSTMENT (P4) so that a perfect octave is heard.

5. Repeat steps (3) and (4) once.

6. Change the voltage of the source alternately from 3.50 to 4.50 volts. (On the 950 Keyboard, play the keys corresponding to the highest F Sharp and the F Sharp an octave below it.) Set the HIGH COMPENSATION (P2) so that a perfect octave is heard.

7. Install all of the modules in their places in the cabinet, and put the back on the cabinet. Allow the synthesizer to run for approximately one hour with the normal number of lighted control voltage switches on. Then recheck the tuning and touch up the adjustments if necessary.

### NOTE

Of the above adjustments, the LOW COMPENSATION ADJUSTMENT will probably need to be reset more frequently (once every month or two). The SCALE and HIGH END ADJUSTMENTS are considerably more stable, and may need to be readjusted once every year or so.

## B. CHECKOUT PROCEDURE

1. Check the output of the adder section as follows: Measure the voltage at the collector of Q5. This voltage should jump about -0.075 volts each time the top FIXED CONTROL VOLTAGE switch is advanced one step. When both FIXED CONTROL VOLTAGE knobs are set on "0", the voltage should be approximately +0.1 volts. If these voltages at the collector of Q5 are observed, then the adder section works properly. If not, check all components in the adder section.

2. Place a 2N4058 transistor in the Q10 socket, if one is not already there. If P1 is a silver-colored wire-wound trimmer, then set as indicated in Figure 6\*. If P1 is a blue carbon trimmer, then set in mid-range. Measure the voltage across R24. The voltage should increase by a factor of two each time the FIXED CONTROL VOLTAGE switch is advanced

one step. When both FIXED CONTROL VOLTAGE knobs are on "0", the voltage across R24 should be approximately .05 volts. If this checks out, then the "exponential generator" section is operating properly. If not, then check all the components in the "exponential generator" section.

3. Check all of the pots, switches, and trimmers to make sure that they function.

a. Operate the FIXED CONTROL VOLTAGE switch through all of its steps. Note that the voltage across R24 doubles (approximately) with each step. The highest voltage should be observed when the knob is on +6.

b. FIXED CONTROL VOLTAGE control (P3) should change the voltage across R24 by a 4:1 ratio (approximately).

c. PULSE WIDTH control should produce a voltage swing of 0 to +12 volts at terminal 6 of the rear strip.

d. SCALE ADJUSTMENT trimmer (P1) should change the ratio of the voltage change across R24 when the FIXED CONTROL VOLTAGE knob is turned.

e. LOW COMPENSATION TRIMMER (P4) should vary the voltage across R24 approximately  $\pm 10\%$  when the FIXED CONTROL VOLTAGE controls are set at "0".

f. HIGH COMPENSATION TRIMMER (P2) should vary the voltage ratio across R24 approximately  $\pm 5\%$  when the FIXED CONTROL VOLTAGE switch is switched between +5 and +6.

g. MID HIGH COMPENSATION (P5) is normally not used. Turn fully counterclockwise that wiper arm reads approximately +9 volts.

## C. NORMAL OPERATING VOLTAGES

The following direct voltages are measured with a transistor or vacuum tube voltmeter with an input impedance of 10 megohms. Voltages of properly operating units may vary as much as  $\pm 5\%$  from these values. Set the front panel controls as follows:

FIXED CONTROL VOLTAGE Switch: +2

FIXED CONTROL VOLTAGE Knob: 0

WIDTH OF PULSE WAVEFORM: Full counterclockwise. Nothing should be connected to the front panel jacks. All lower console voltage switches should be off. Large deviations from these voltages (See Table 1 on Figure 6) indicate trouble in the unit under test.

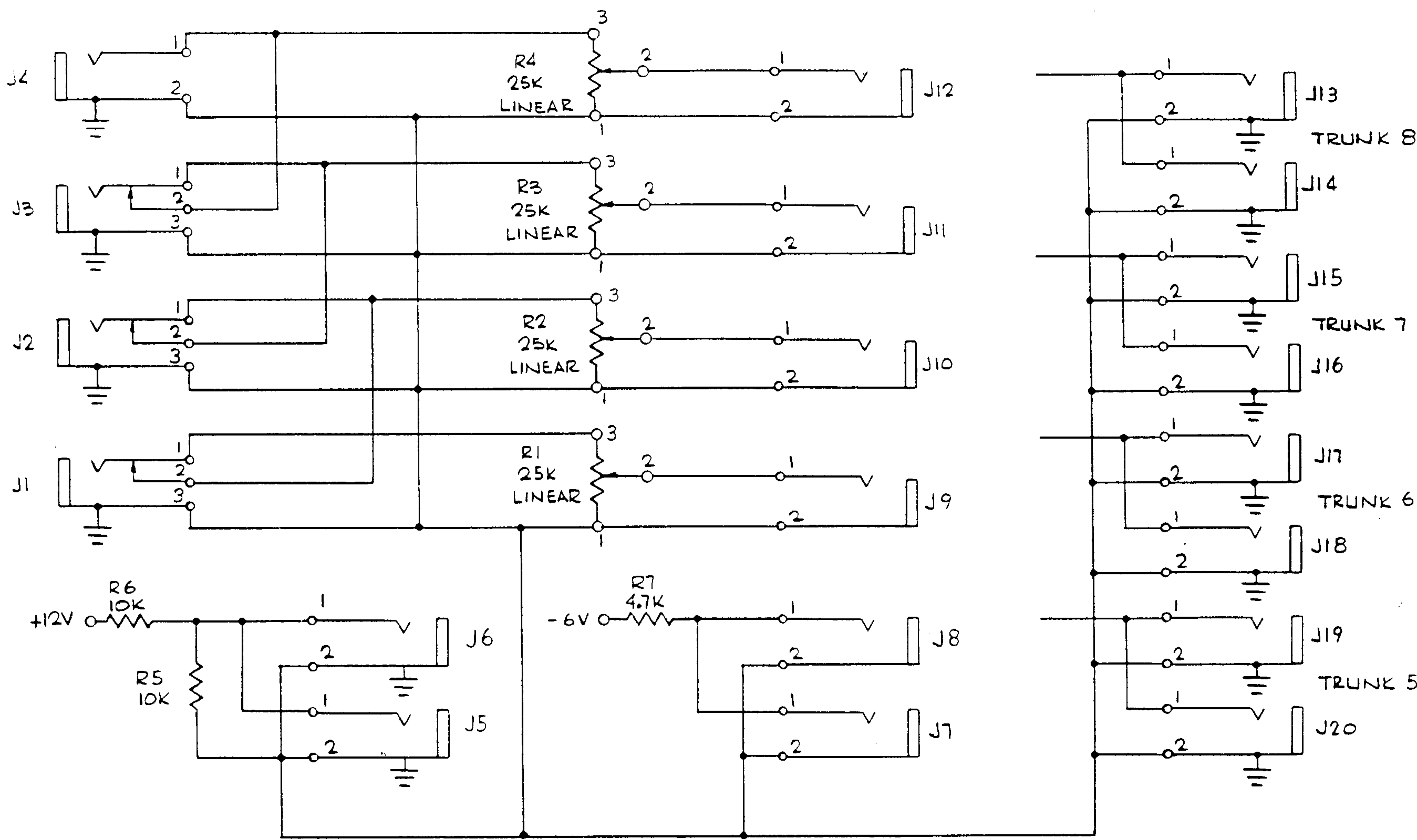

MOOG MUSIC INC.  
 SCHEMATIC, CONSOLE PANEL  
 SYSTEM 35 993-042184 08-048

FIGURE 5 CONSOLE PANEL SYSTEM 35

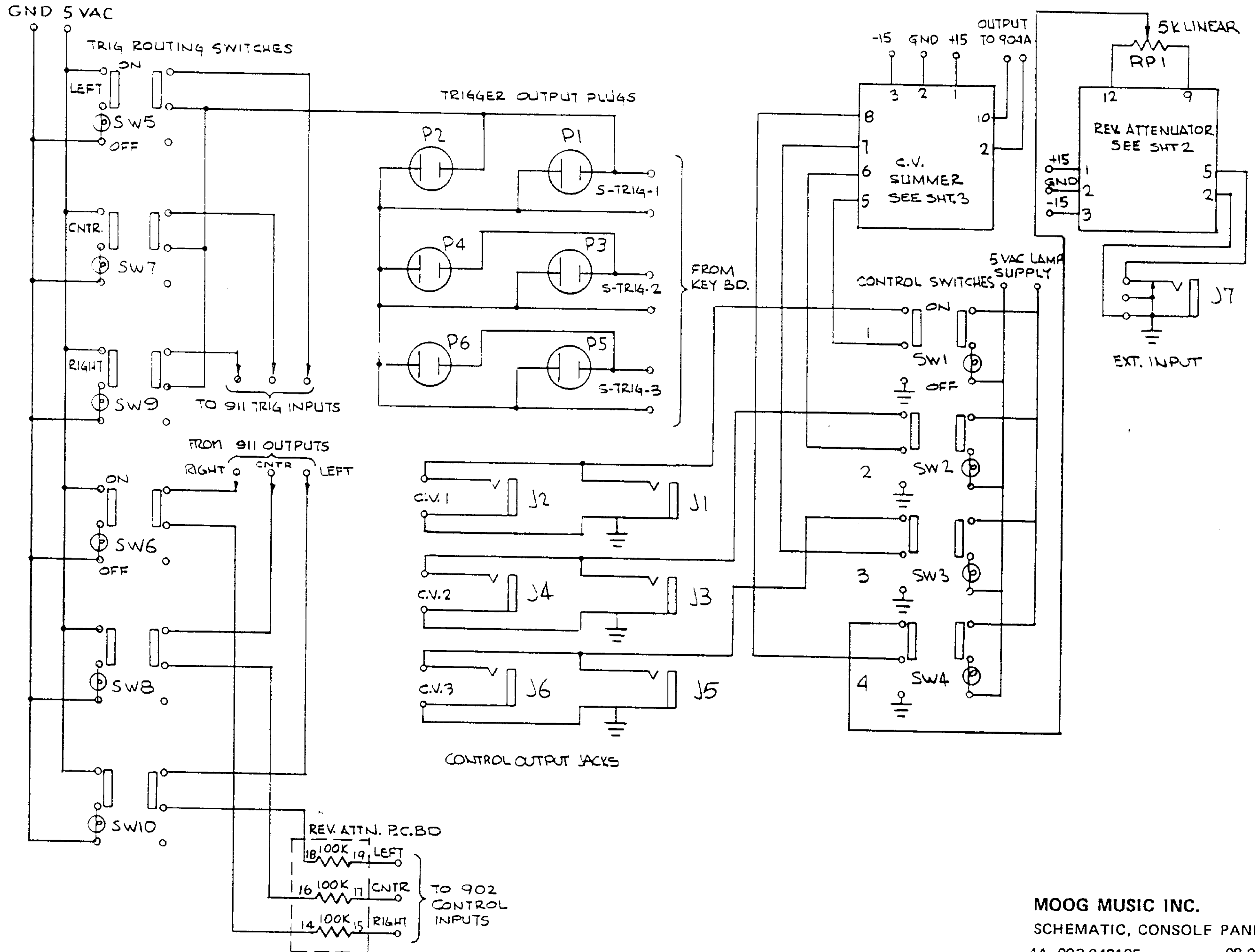

MOOG MUSIC INC.  
 SCHEMATIC, CONSOLE PANEL  
 4A 993-042185 08-050

FIGURE 4 CONSOLE PANEL MODEL 4A

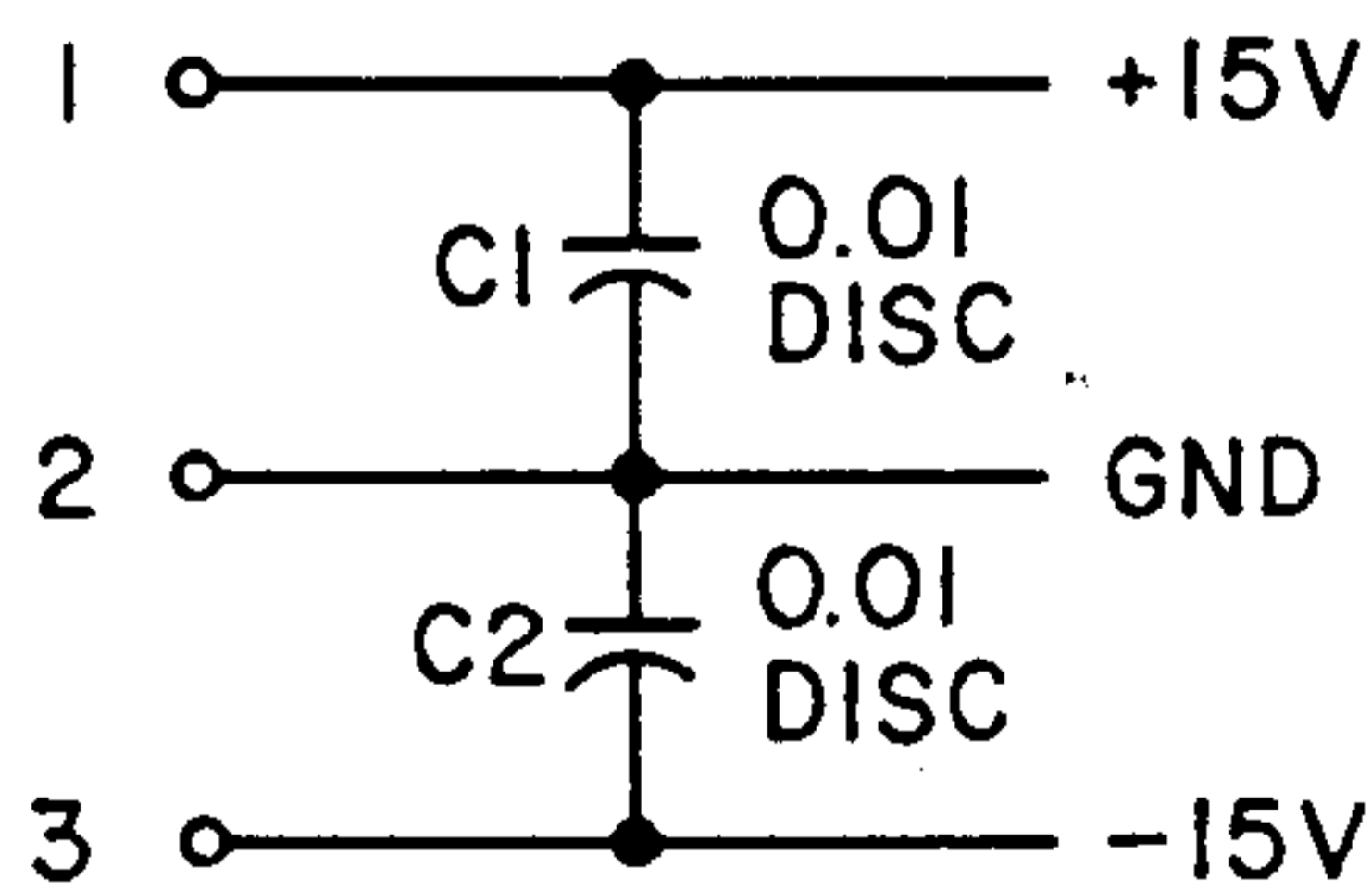
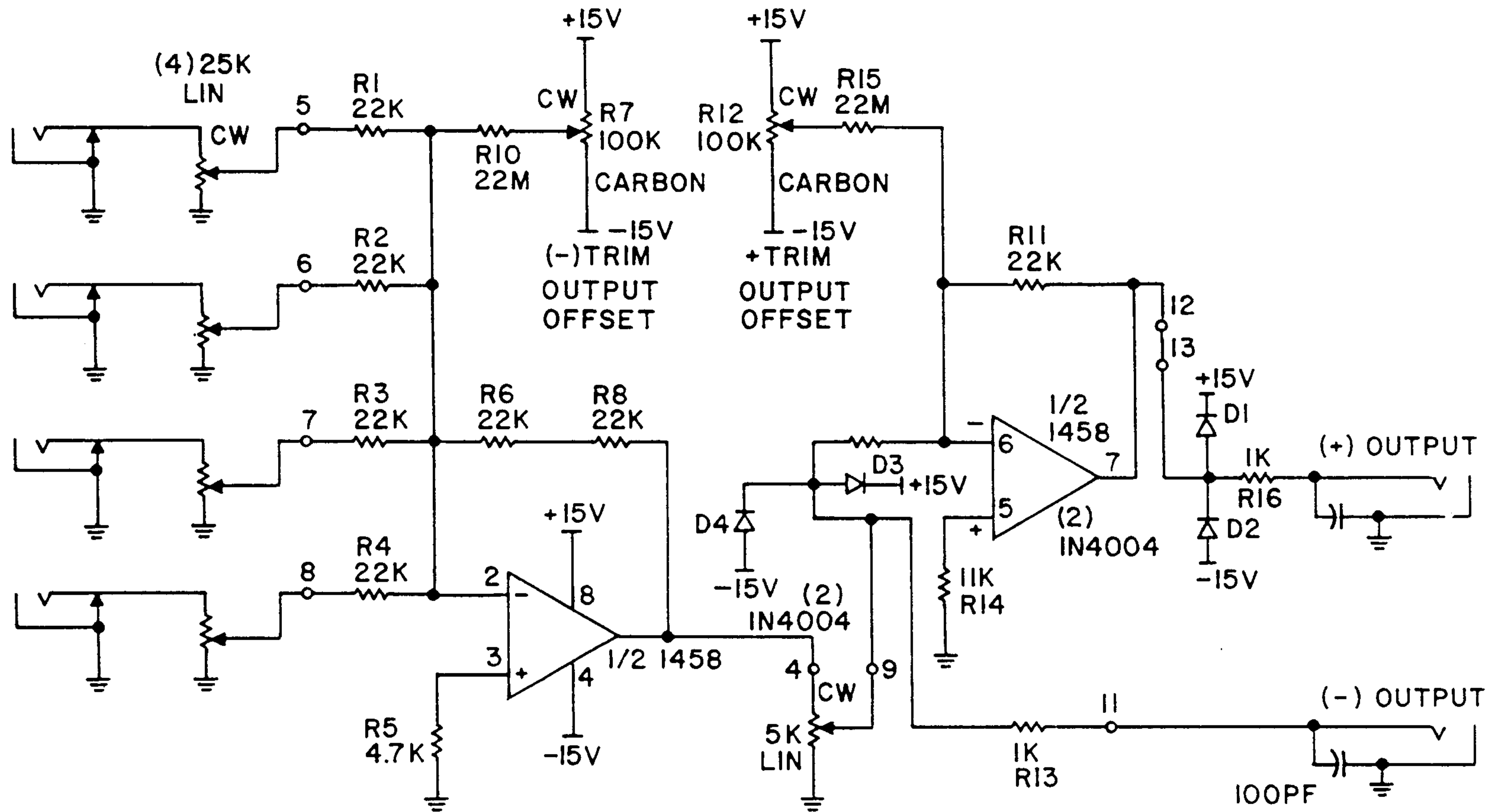

- ① ALL RESISTORS MAY BE 5% DISCRETE
- ② R1, 2, 3, 4, 6, 8, 9, 11 MAY BE DIP

MOOG MUSIC INC.  
 SCHEMATIC, CONTROL PANEL 3A MIXER  
 993-042239

FIGURE 3 CONTROL PANEL MIXER MODEL 3A

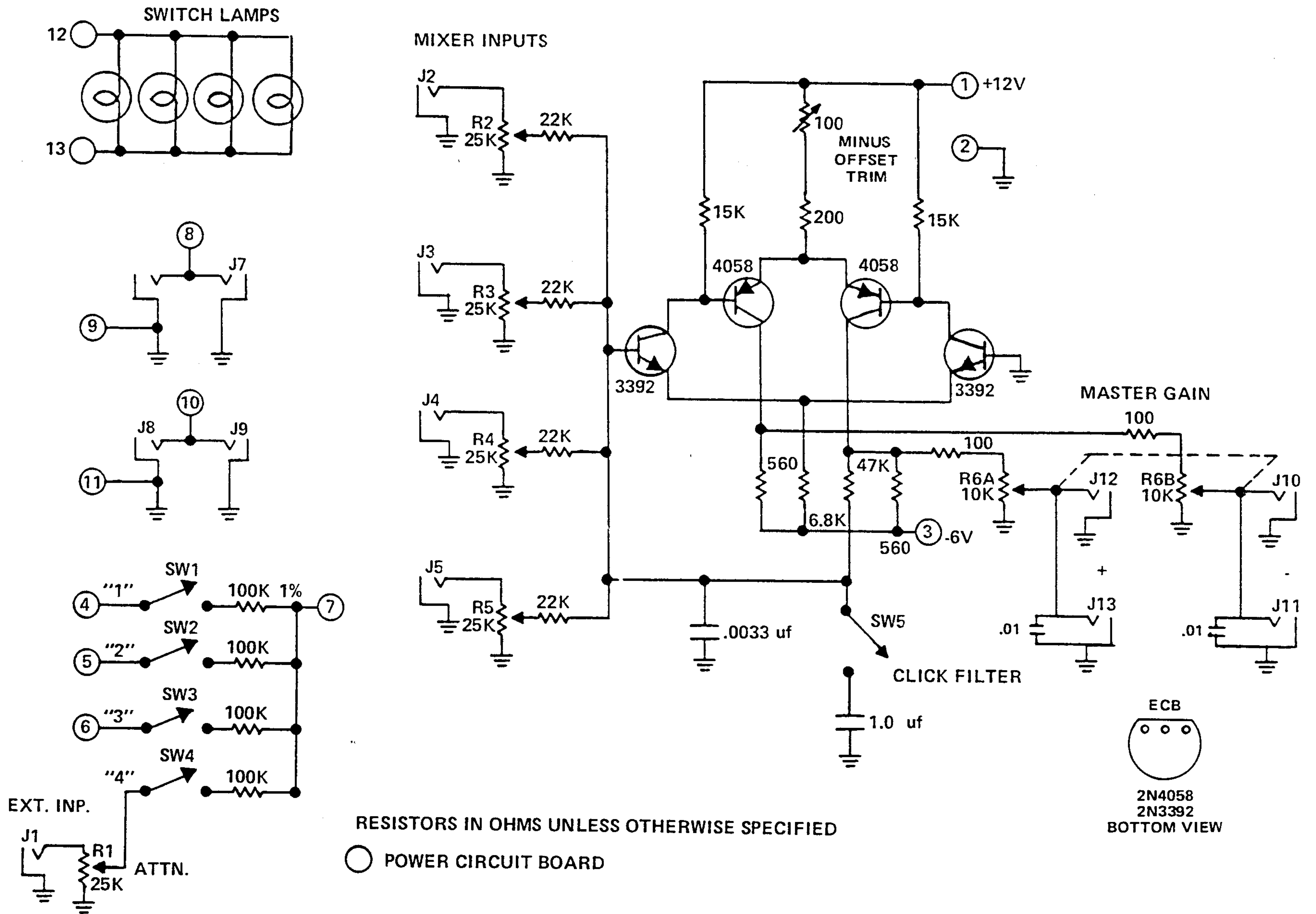
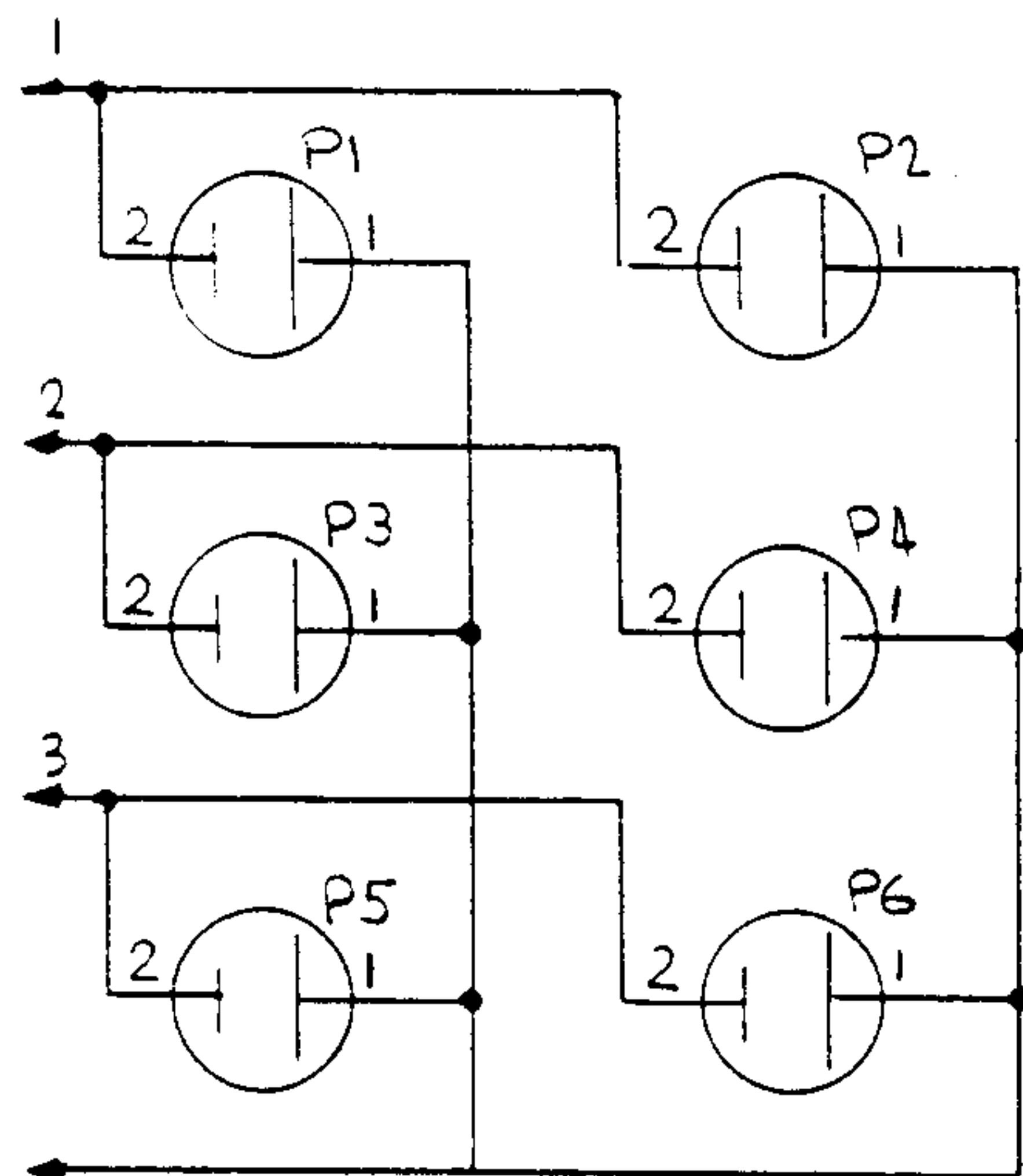

FIGURE 2 CONSOLE PANEL MODEL 3



S-TRIGS  
FROM  
CONTROLLERS



S-TRIG  
GND

S-TRIG OUTPUTS

CONTROL  
VOLTAGES  
FROM  
CONTROLLERS

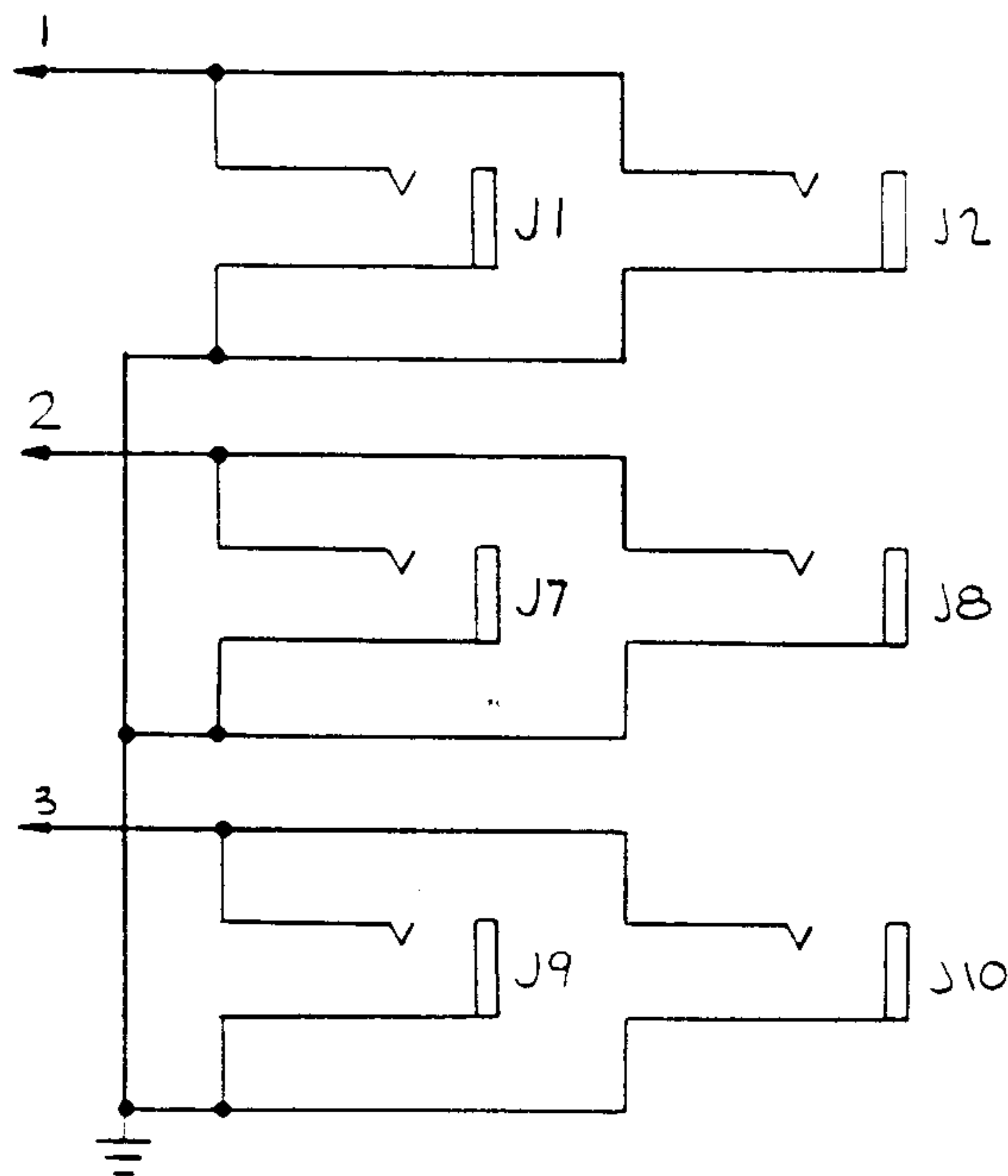

CONTROL OUTPUTS

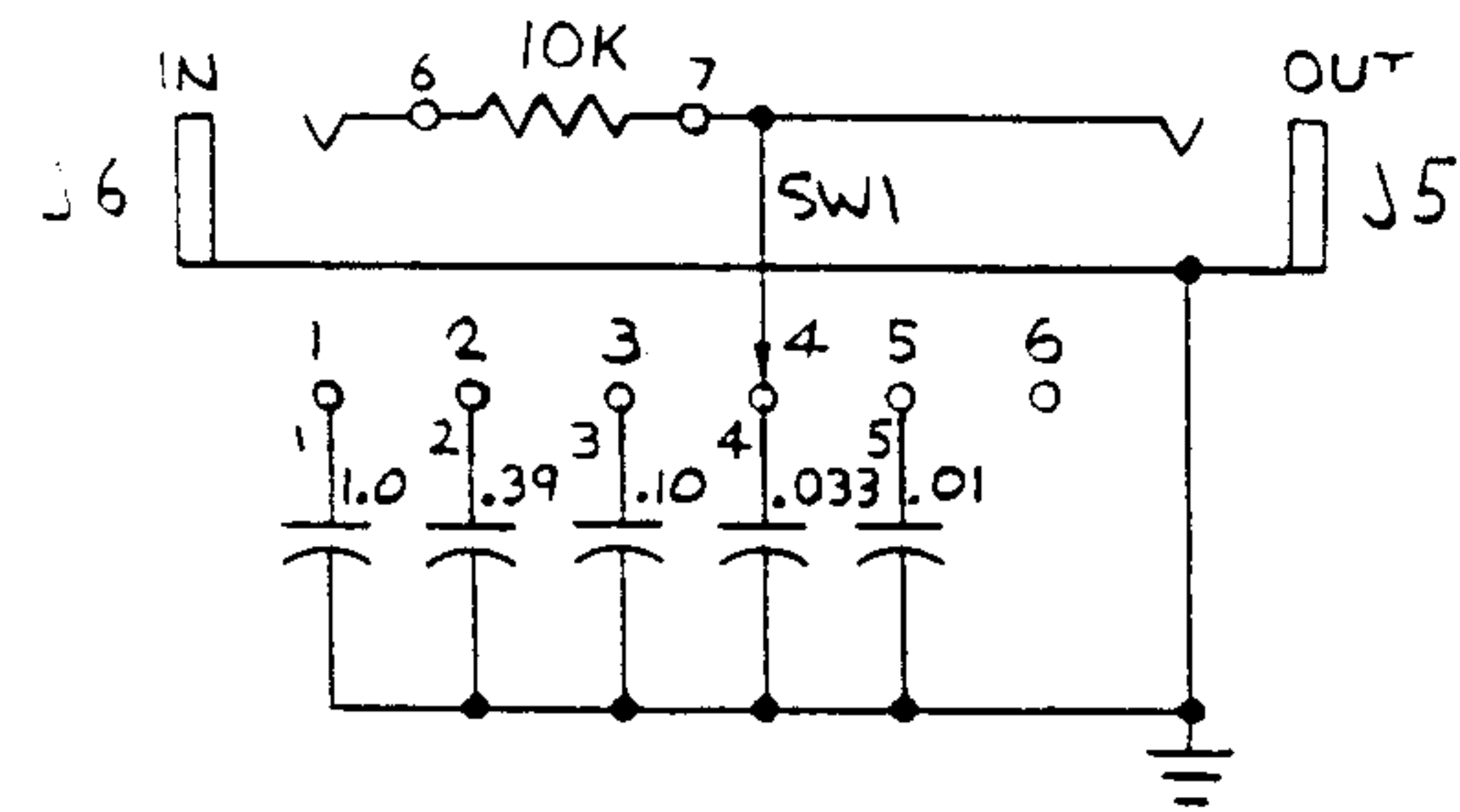
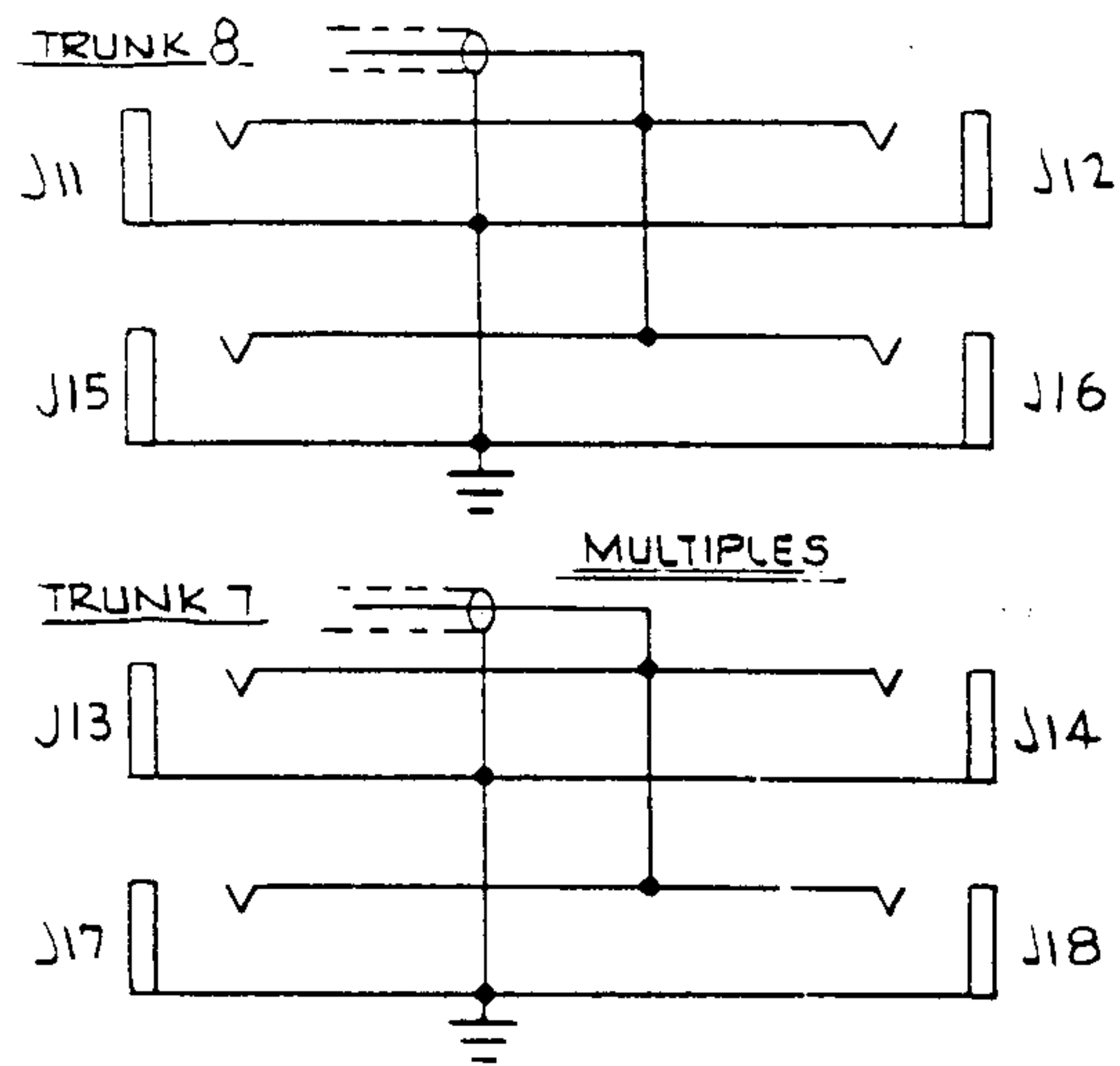

LOWPASS FILTER

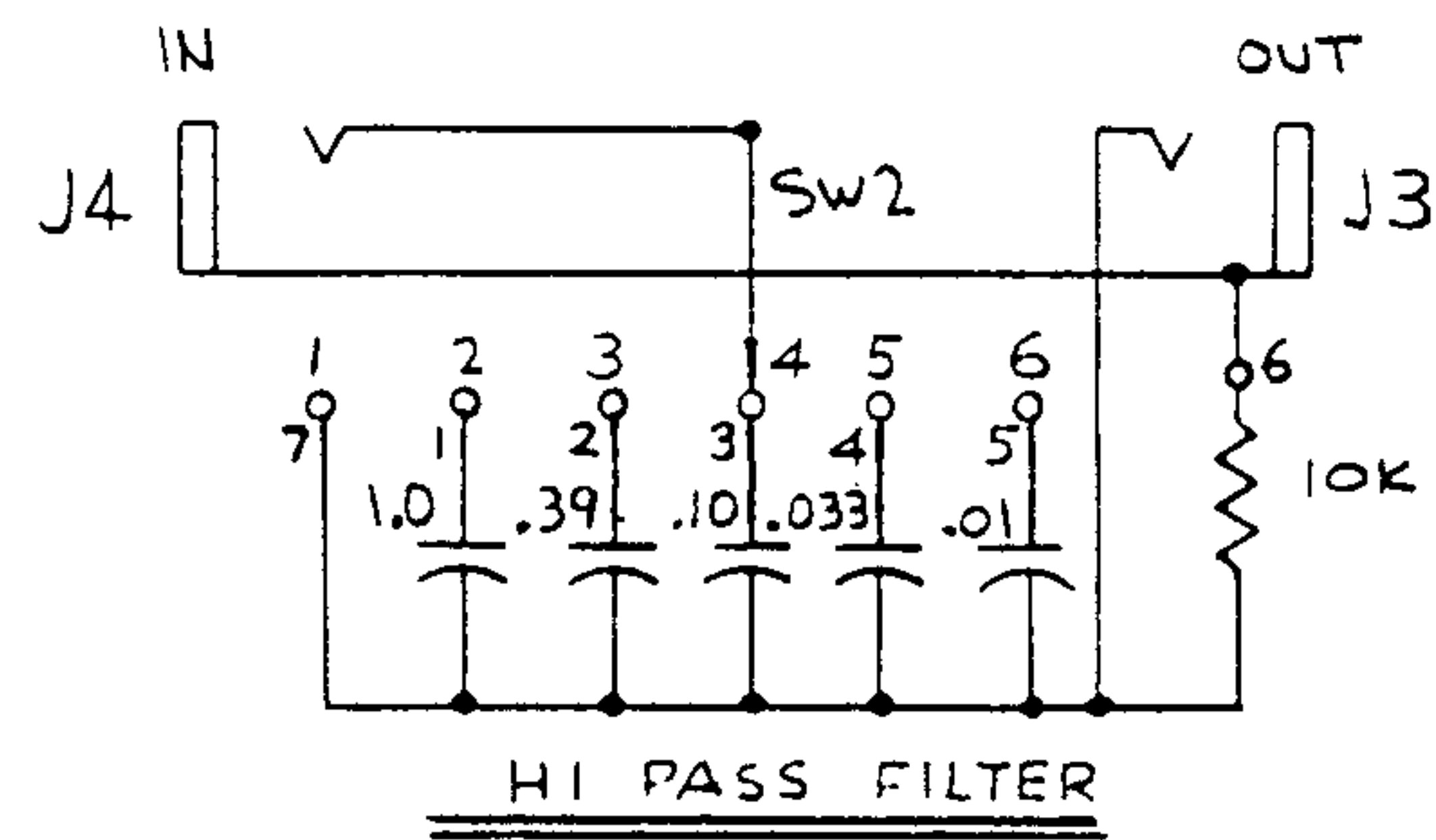

HI PASS FILTER

MOOG MUSIC INC.  
SCHEMATIC, CONSOLE PANEL  
2A 993-042141 08-049

FIGURE 1 CONSOLE PANEL MODEL 2A

## CONTENTS (Continued)

MODEL	DRAWING NO.	TITLE	PAGE
992	993-041804	Figure 37 Controller for 904s . . . . .	42
995	993-041812	Figure 38 Attenuators . . . . .	43
1630	993-042653	Figure 39 Dome Filter (Card No. 1) -Bode Frequency Shifter . . . . .	44
1630	993-042654	Figure 40 Variable Oscillator (Card No. 2) -Bode Frequency Shifter . . . . .	45
1630	993-042655	Figure 41 Fixed Oscillator (Card No. 3) -Bode Frequency Shifter . . . . .	46
1630	993-042656	Figure 42 Modulator/Output (Card No. 4) -Bode Frequency Shifter . . . . .	46
SYN 15	993-041817	Figure 43 Interconnection . . . . .	47
SYN 15	993-041817	Figure 44 Interconnection . . . . .	48
SYN 35/55	993-041778	Figure 45 Trigger Buffer . . . . .	49
SYN 35/55	993-042657	Figure 46 Cabinet Wiring . . . . .	50
SYN 35	993-041878	Figure 47 Cabinet Wiring . . . . .	51
SYN 55	993-041879	Figure 48 Cabinet Wiring . . . . .	52
		Matching Transistor Circuits . . . . .	53

# CONTENTS

MODEL	DRAWING NO.	TITLE	PAGE
SYN 35/55		Frontispiece . . . . .	ii
2A	993-042141	Figure 1 Console Panel . . . . .	1
3	993-042644	Figure 2 Console Panel . . . . .	2
3A	993-042239	Figure 3 Control Panel Mixer . . . . .	3
4A	993-042185	Figure 4 Console Panel . . . . .	4
35	993-042184	Figure 5 Console Panel . . . . .	5
901A	993-042645	Figure 6 Oscillator Controller . . . . .	7
901B	993-042646	Figure 7 Oscillator . . . . .	9
901C	993-042647	Figure 8 Output Stage . . . . .	10
902	993-041813	Figure 9 Voltage Controlled Amplifier . . . . .	11
903A	993-041818	Figure 10 Random Signal Source . . . . .	12
904A	993-041805	Figure 11 Voltage Controlled Low Pass Filter . . . . .	13
904B	997-041807	Figure 12 Voltage Controlled High Pass Filter . . . . .	14
904C	993-041809	Figure 13 Voltage Controlled Filter Coupler . . . . .	15
905	993-042648	Figure 14 Reverberation Unit . . . . .	16
907/907A	993-041838	Figure 15 Fixed Filter Bank . . . . .	17
909/910	994-042128	Figure 16 Power Supply . . . . .	18
911	993-041815	Figure 17 Envelope Generator . . . . .	19
911A	993-041780	Figure 18 Dual Trigger Delay . . . . .	20
912	993-041776	Figure 19 Envelope Follower . . . . .	21
914	993-041820	Figure 20 Fixed Filter . . . . .	22
921	993-041877	Figure 21 Oscillator . . . . .	23
921A	993-041835	Figure 22 Oscillator Driver . . . . .	25
921B	993-041875	Figure 23 Oscillator . . . . .	26
923	993-041876	Figure 24 Filters/Noise Source . . . . .	27
930	993-041841	Figure 25 Power Supply . . . . .	29
950	993-041831	Figure 26 Keyboard . . . . .	30
950B	993-042650	Figure 27 Programmer . . . . .	31
951	993-041831	Figure 28 Keyboard . . . . .	32
952	993-041832	Figure 29 Two Note Keyboard . . . . .	34
956	993-042651	Figure 30 Ribbon Controller . . . . .	35
960	993-041823	Figure 31 Sequential Controller (Circuit Board 1) . . . . .	36
960	993-041823	Figure 32 Sequential Controller (Circuit Board 2) . . . . .	37
960	993-041823	Figure 33 Sequential Controller (Circuit Board 3) . . . . .	38
961	993-041827	Figure 34 Interface . . . . .	39
962	993-041829	Figure 35 Sequential Switch . . . . .	40
984	993-042652	Figure 36 Four Channel Mixer . . . . .	41

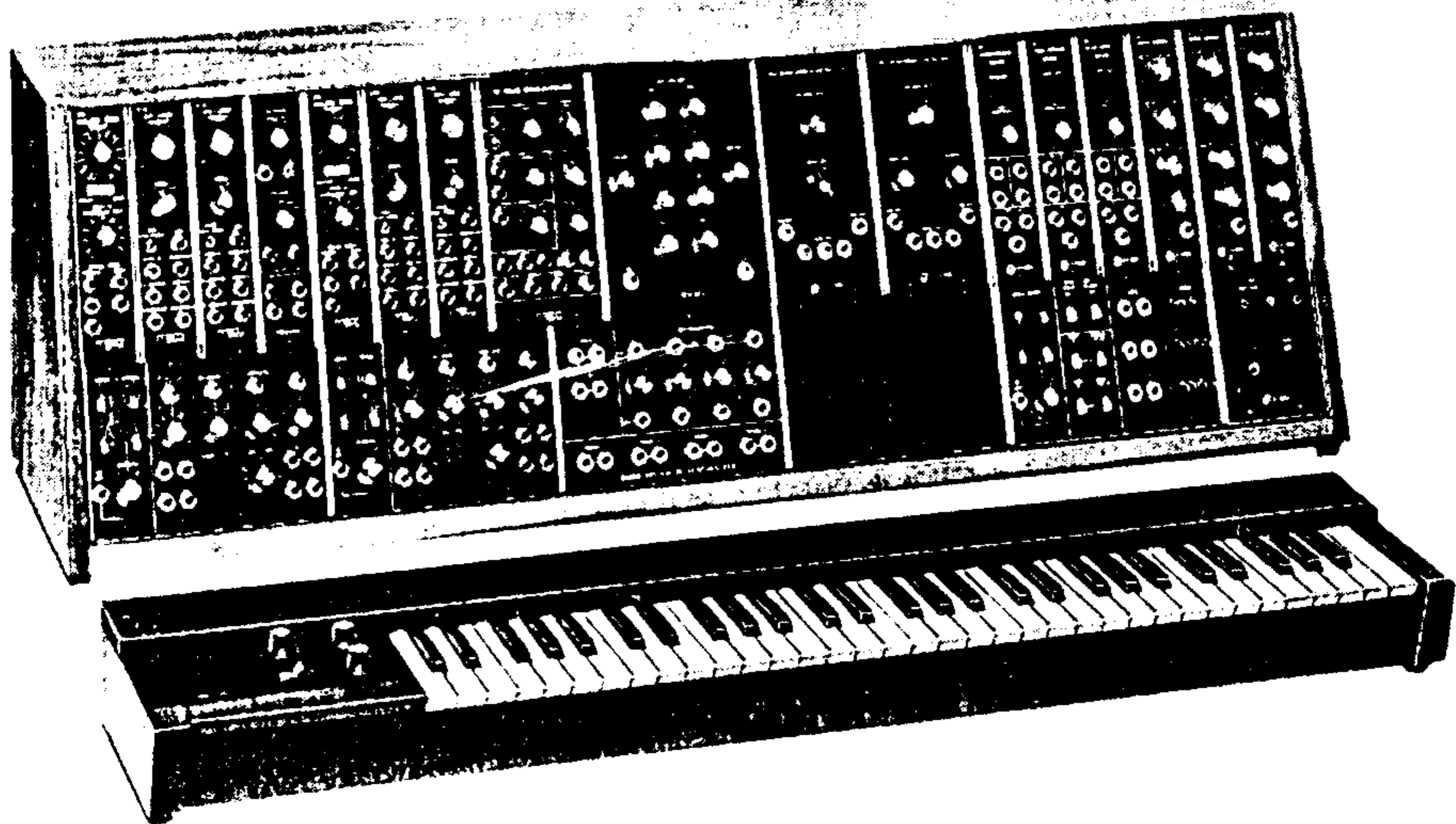

SYSTEM 35

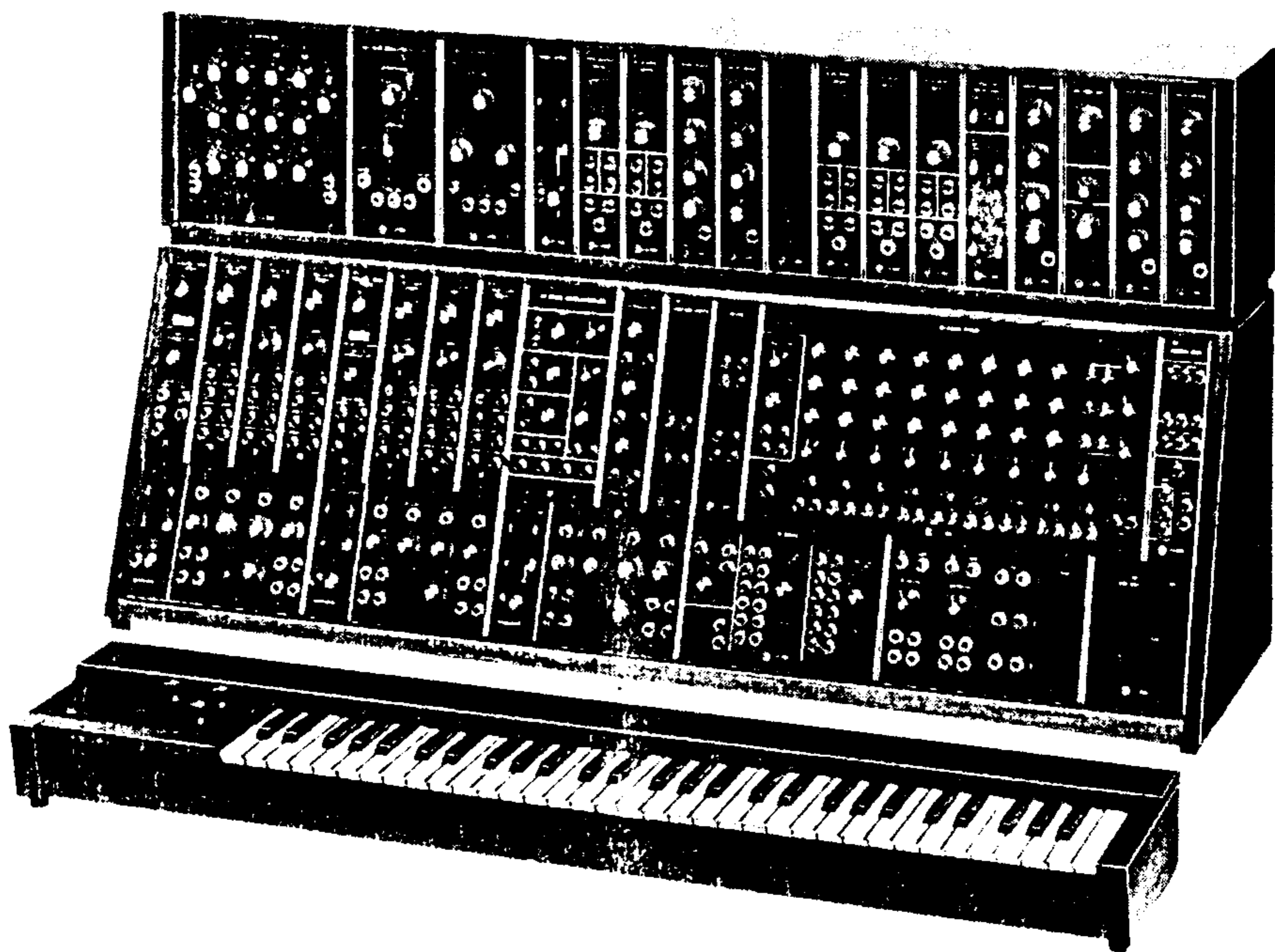

SYSTEM 55

MOOG SYNTHESIZER SYSTEM 35 AND SYSTEM 55

UPPER  
CABINET  
ASSEMBLY

1 = +12V  
2 = GND  
3 = -6V

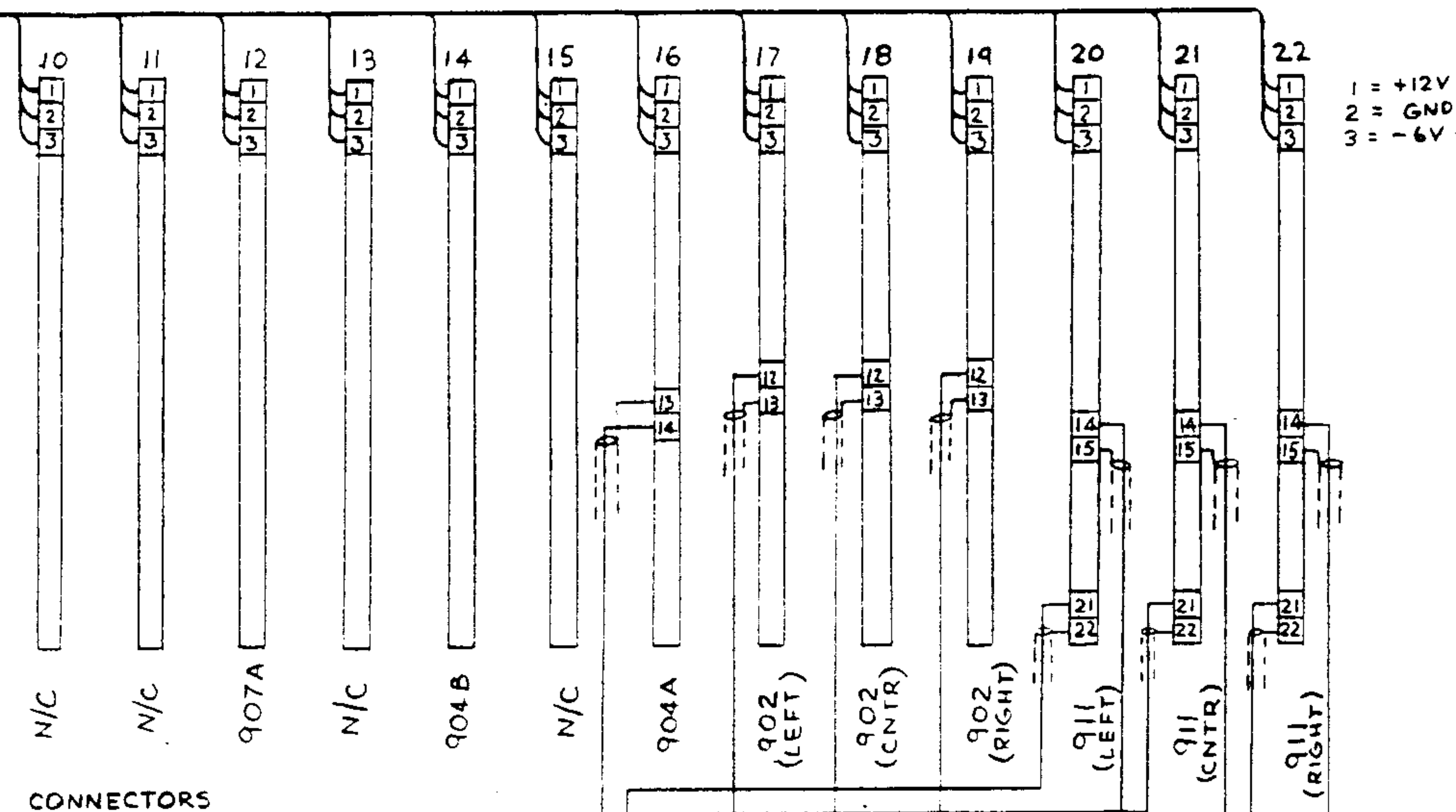

CONNECTORS

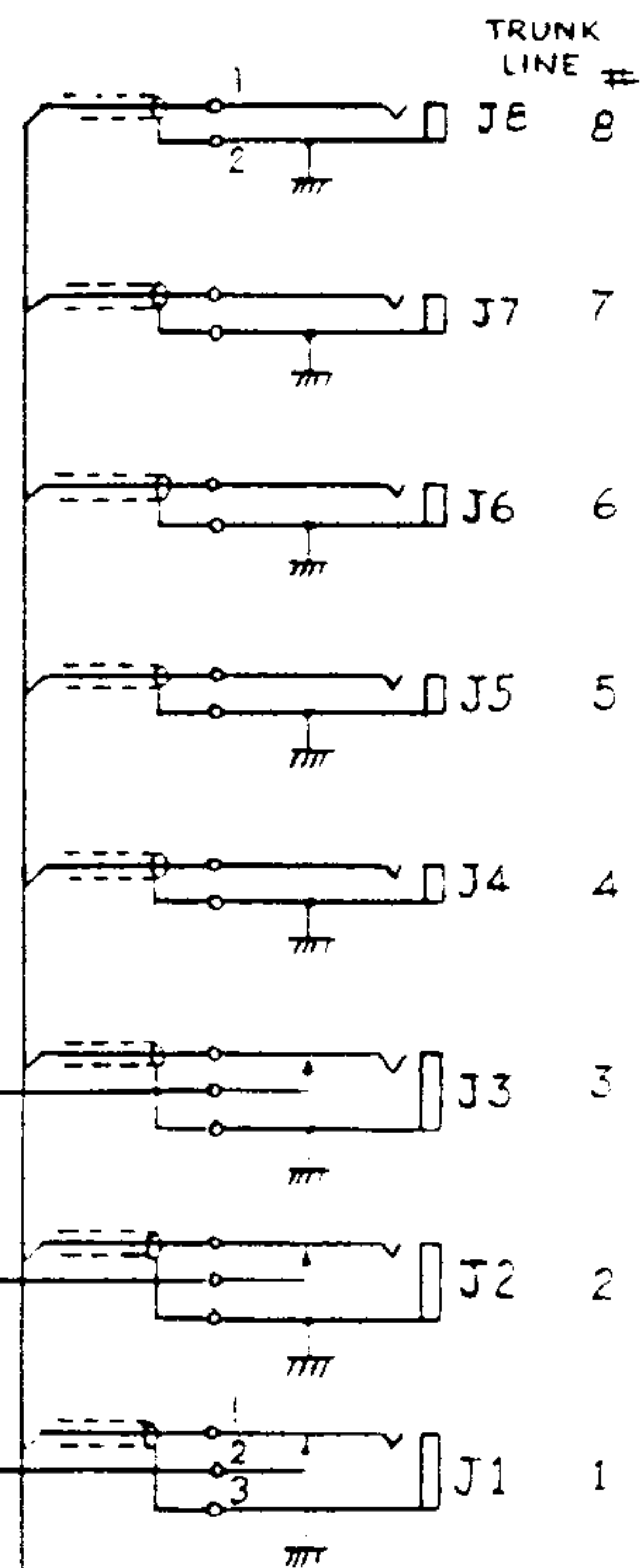
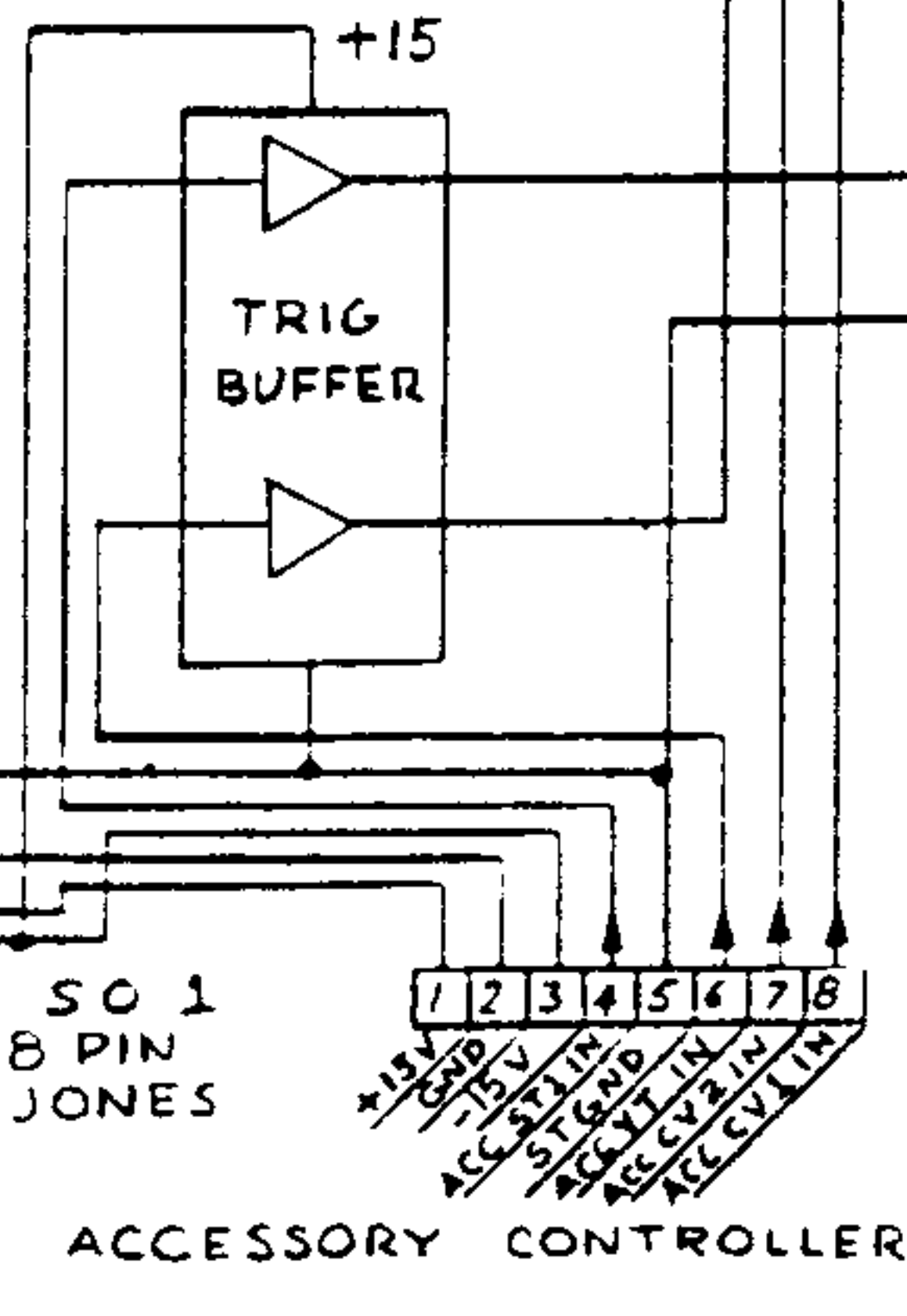
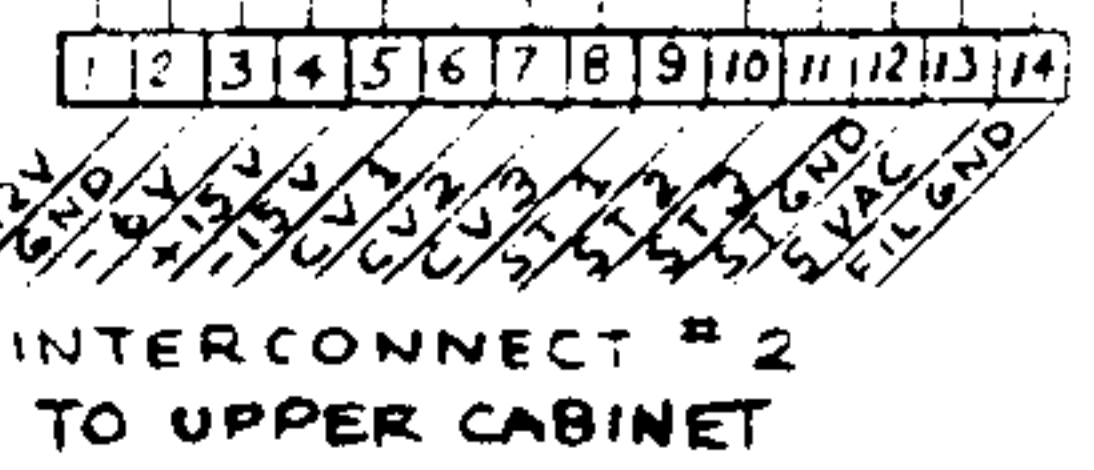
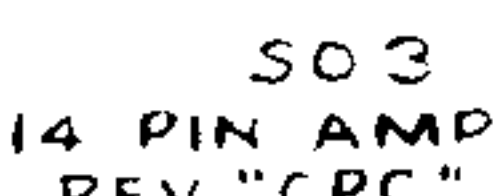
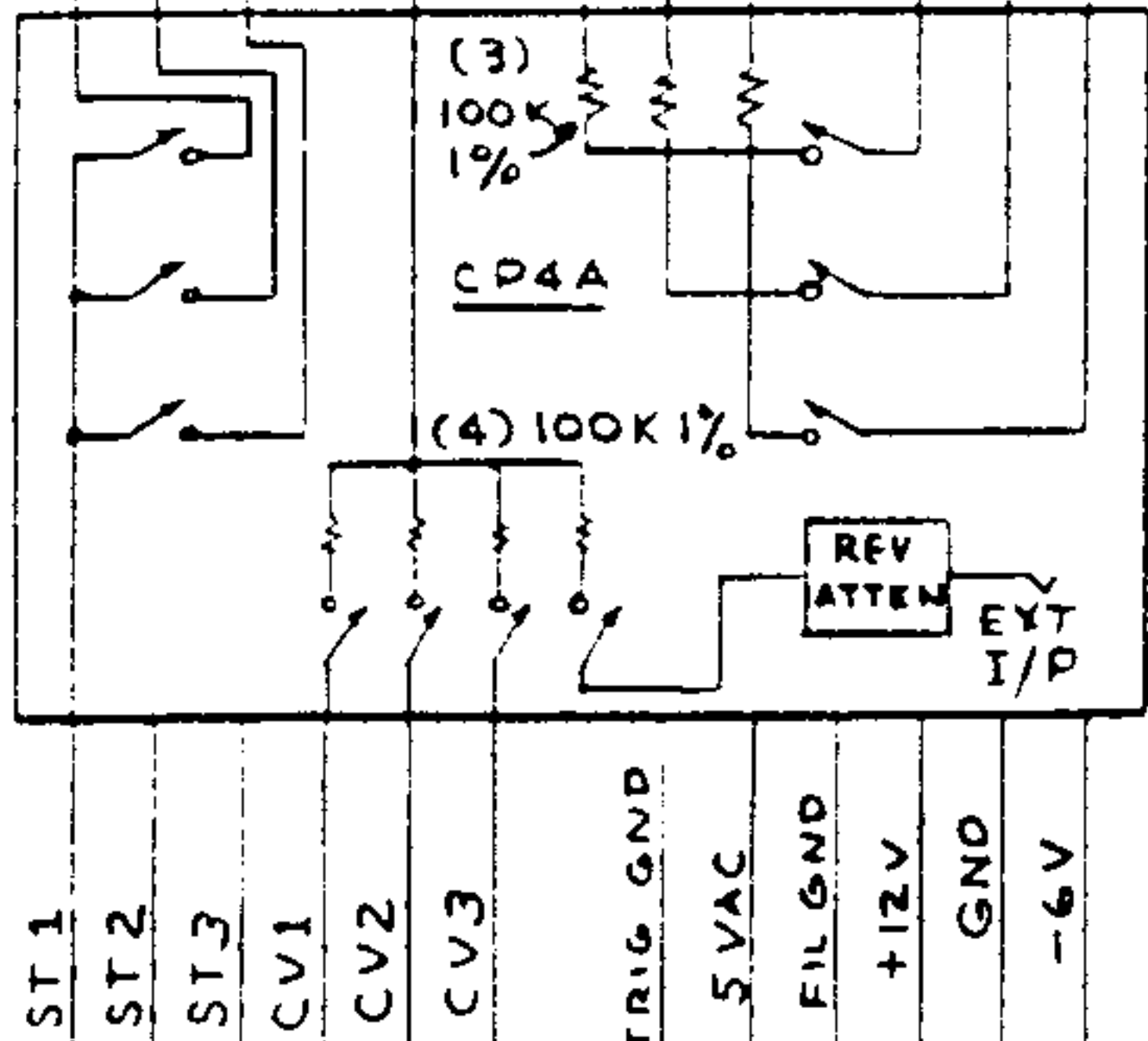
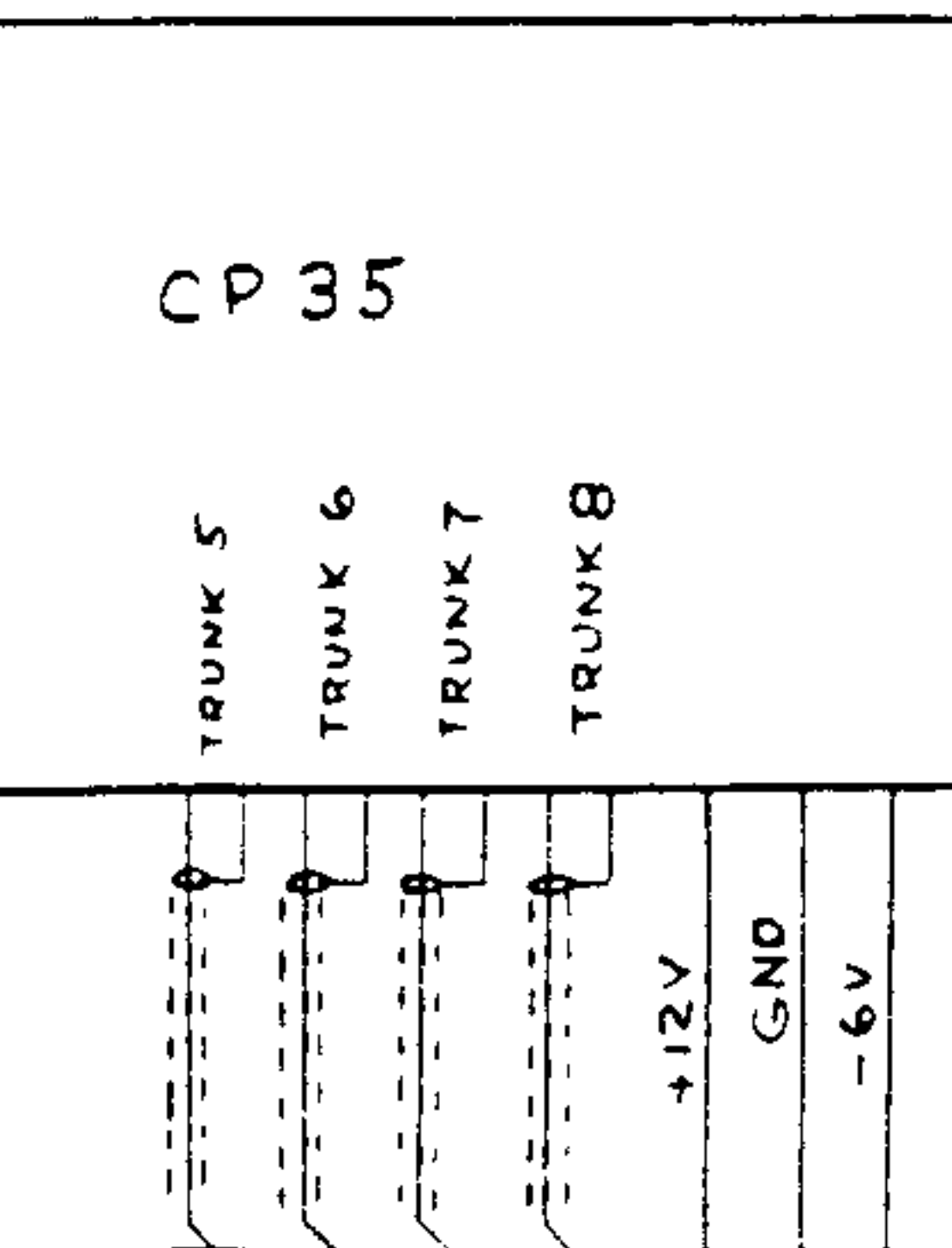

MOOG MUSIC INC.  
SCHEMATIC, SYSTEM 35  
CABINET WIRING SCHEMATIC  
993-041878 08-043

FIGURE 47 CABINET WIRING, SYSTEM 35