

Title			VOYAGER CPU		
Size	Number	Revision			
A3		11-400B			
Date:	21-Apr-2003	Sheet of	1	4	
File:	C:\WINDOWS\DESKTOP\11-400A.S01	Drawn By:			

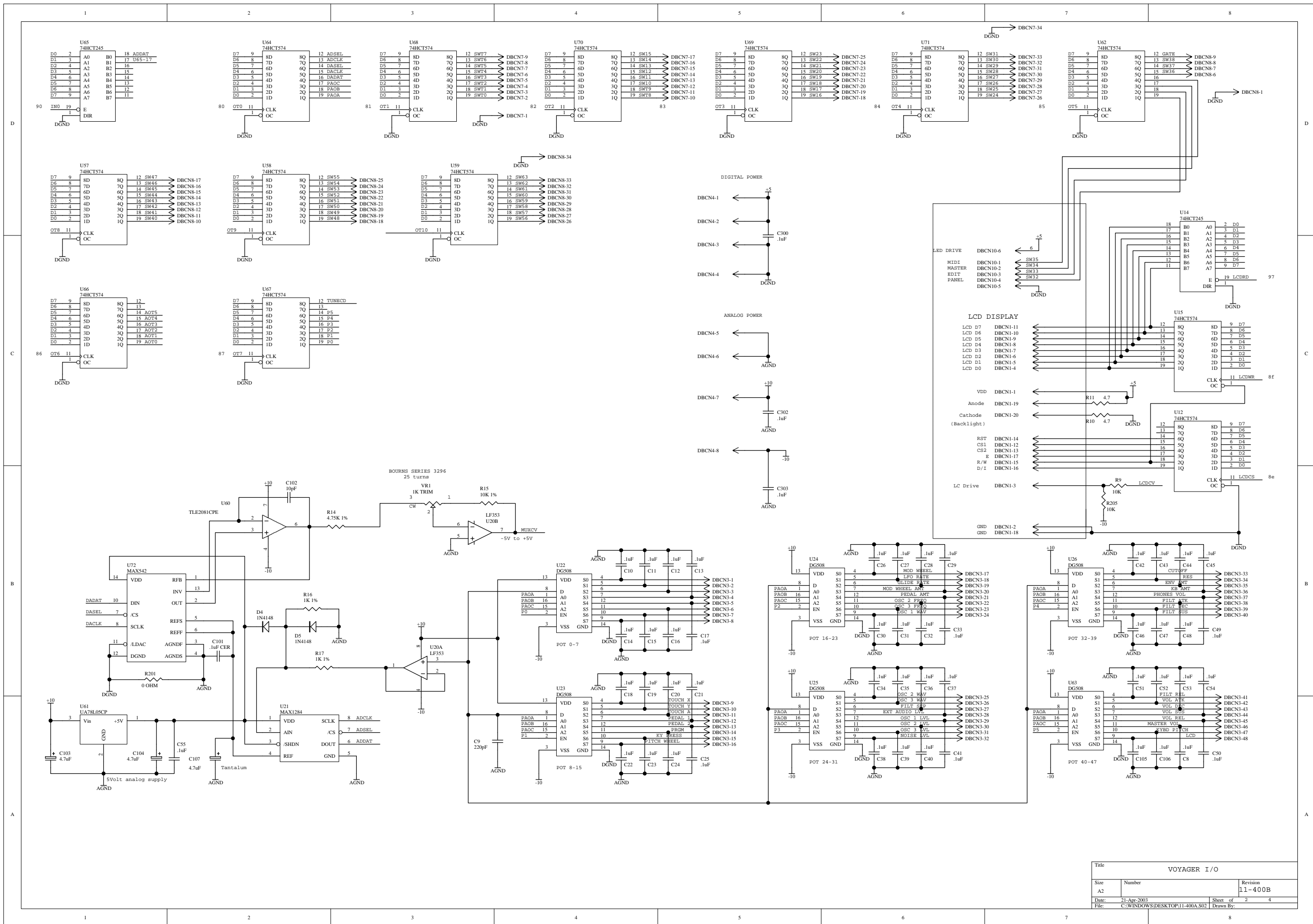

Title		
VOYAGER I/O		
Size	Number	Revision
A2		11-400B
Date:	21-Apr-2003	Sheet of 2 4
File:	C:\WINDOWS\DESKTOP\11-400A.S02	Drawn By:

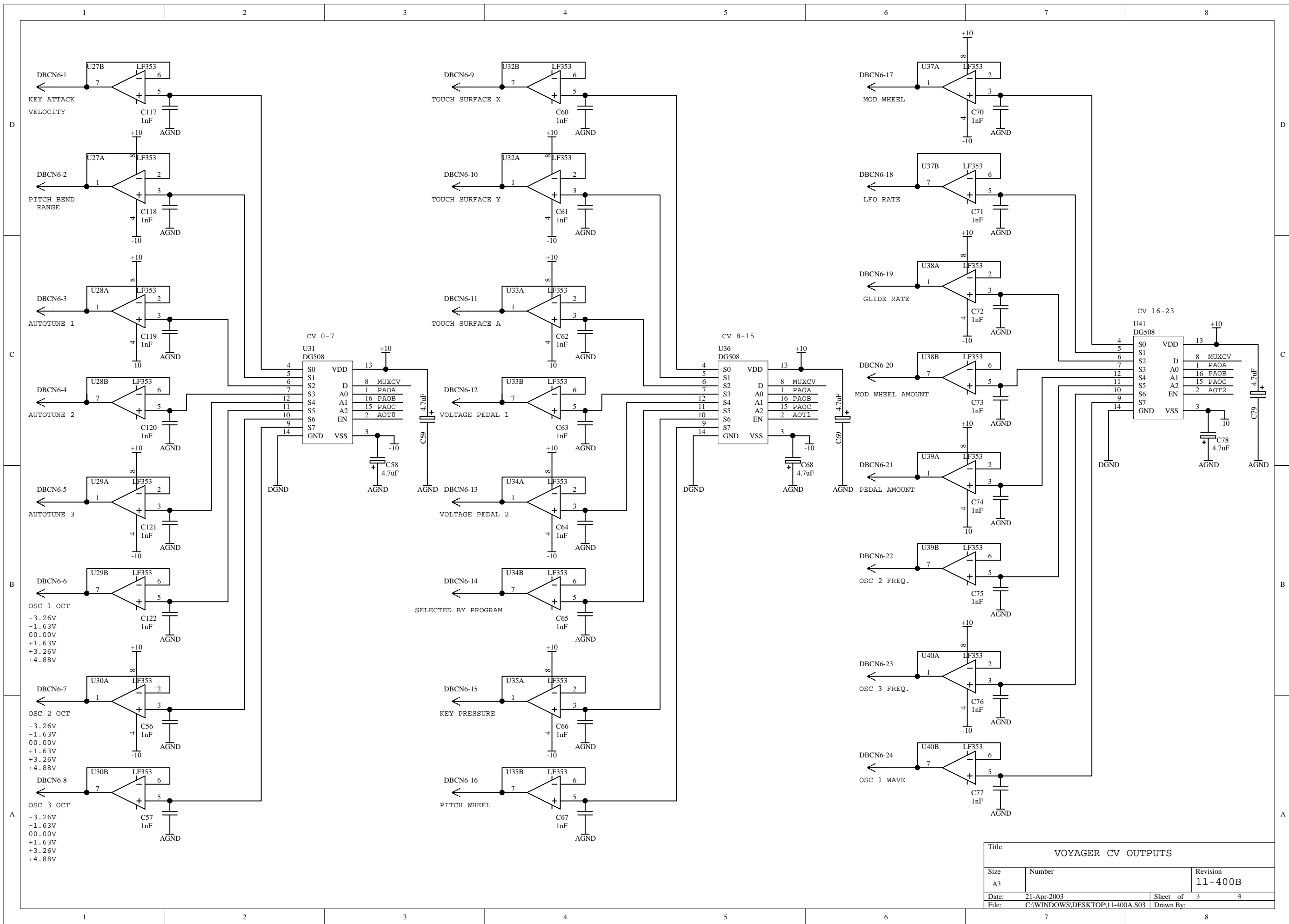

Title			VOYAGER CV OUTPUTS		
Size	Number		Revision		
A3			11-400B		
Date:	21-Apr-2003		Sheet of	3 4	
File:	C:\WINDOWS\DESKTOP\11-400A.S03		Drawn By:		

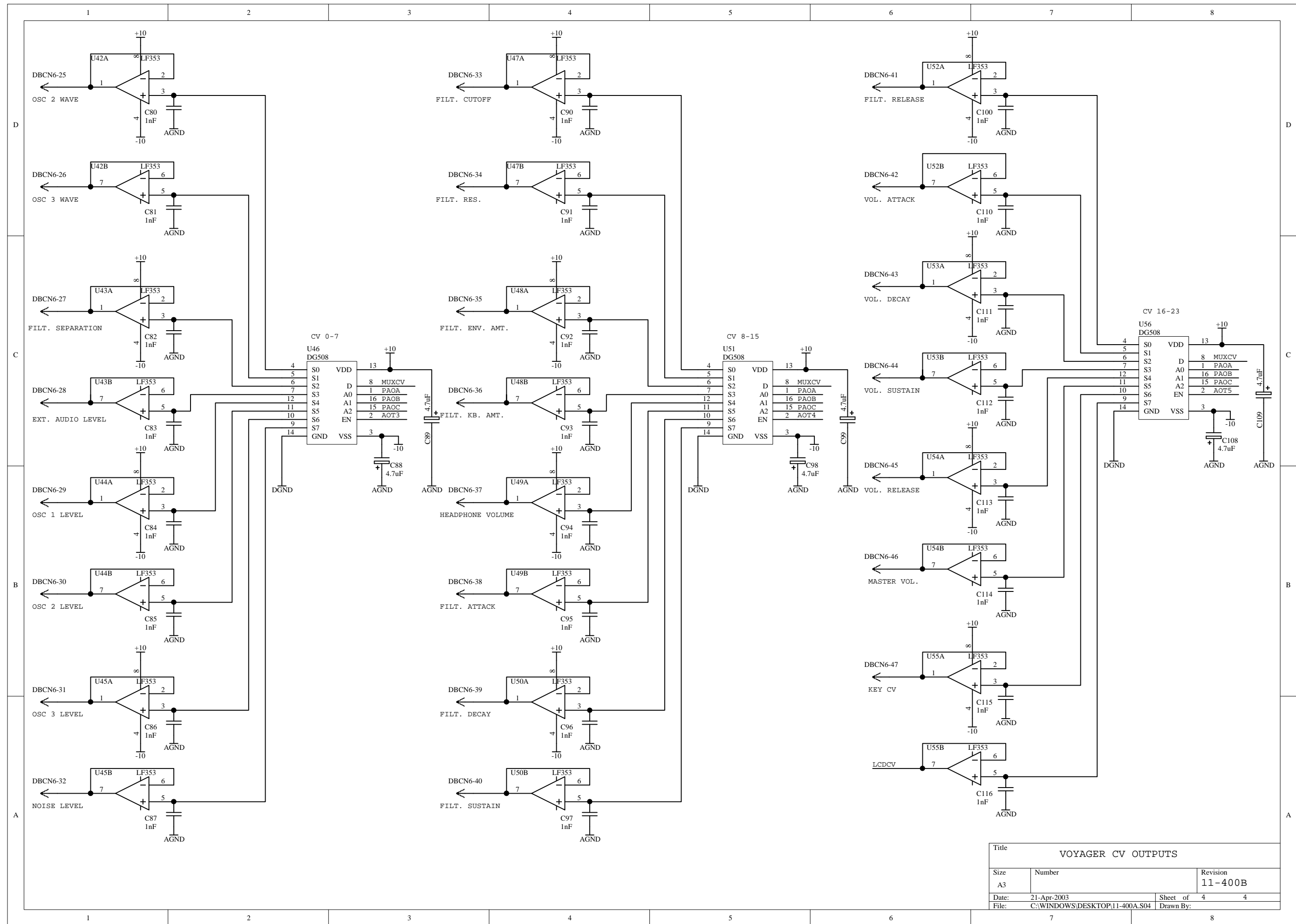

Title			VOYAGER CV OUTPUTS		
Size	Number		Revision		
A3			11-400B		
Date:	21-Apr-2003		Sheet of	4	4
File:	C:\WINDOWS\DESKTOP\11-400A.S04		Drawn By:		

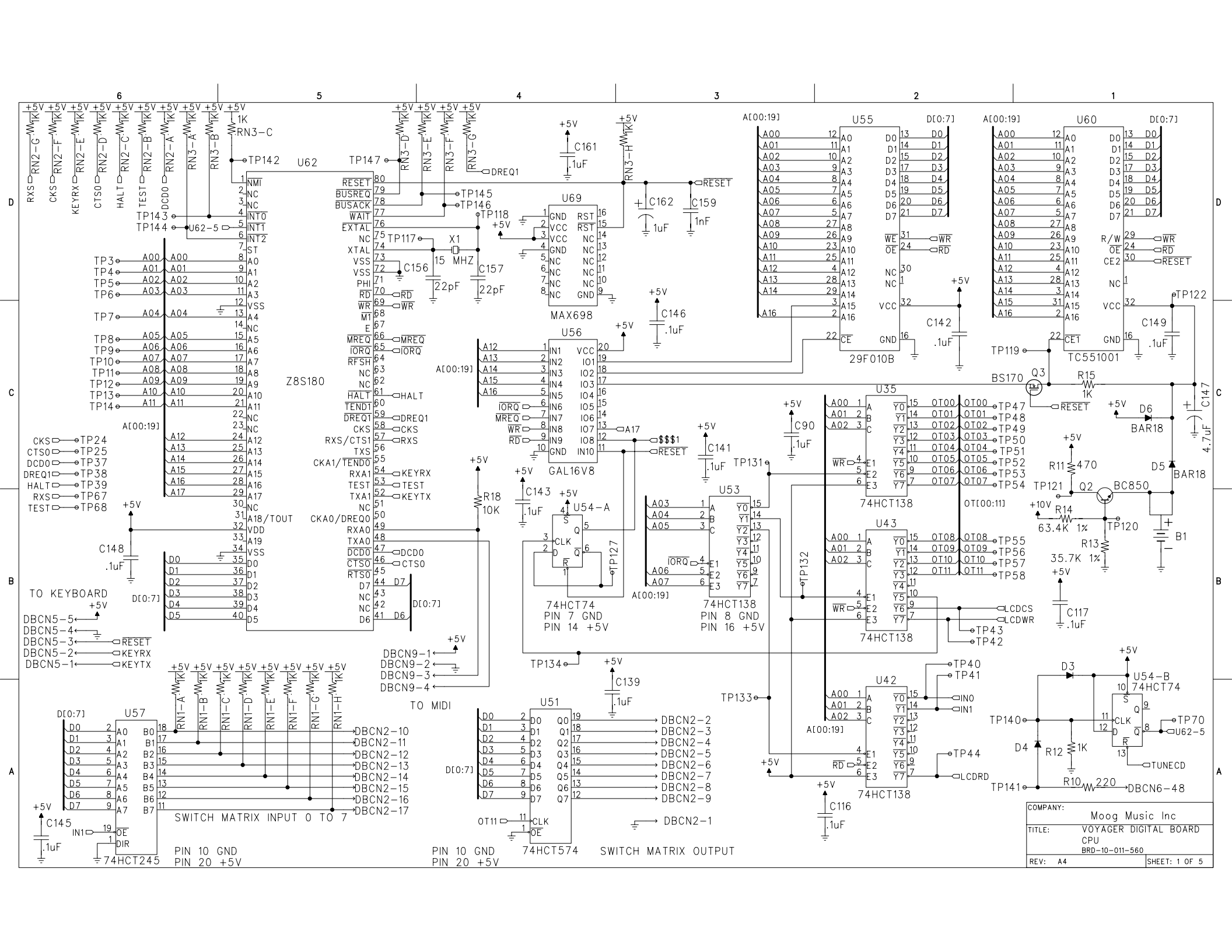

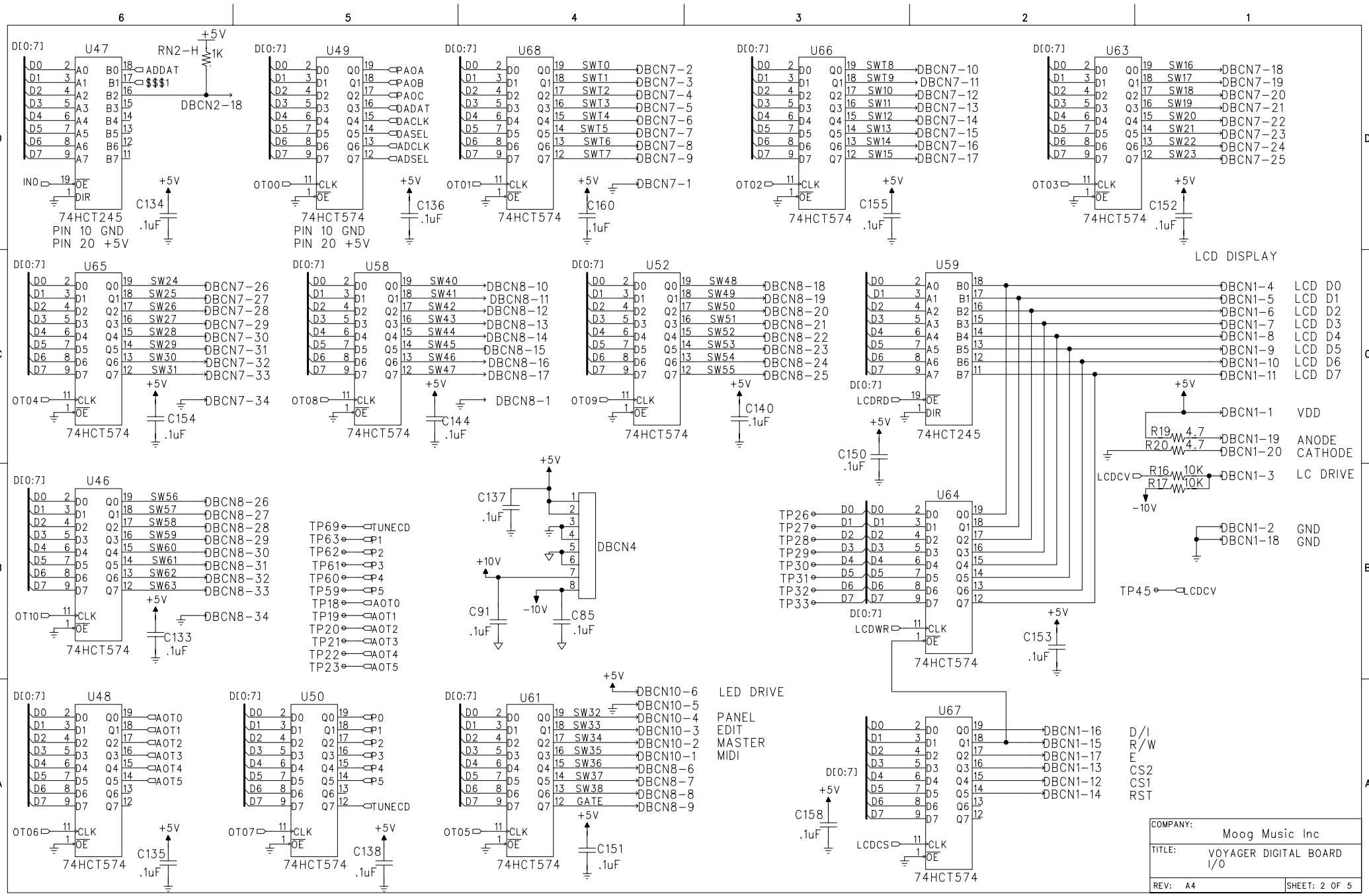

COMPANY:	Moog Music Inc
TITLE:	VOYAGER DIGITAL BOARD I/O
REV:	A4
SHEET:	2 OF 5

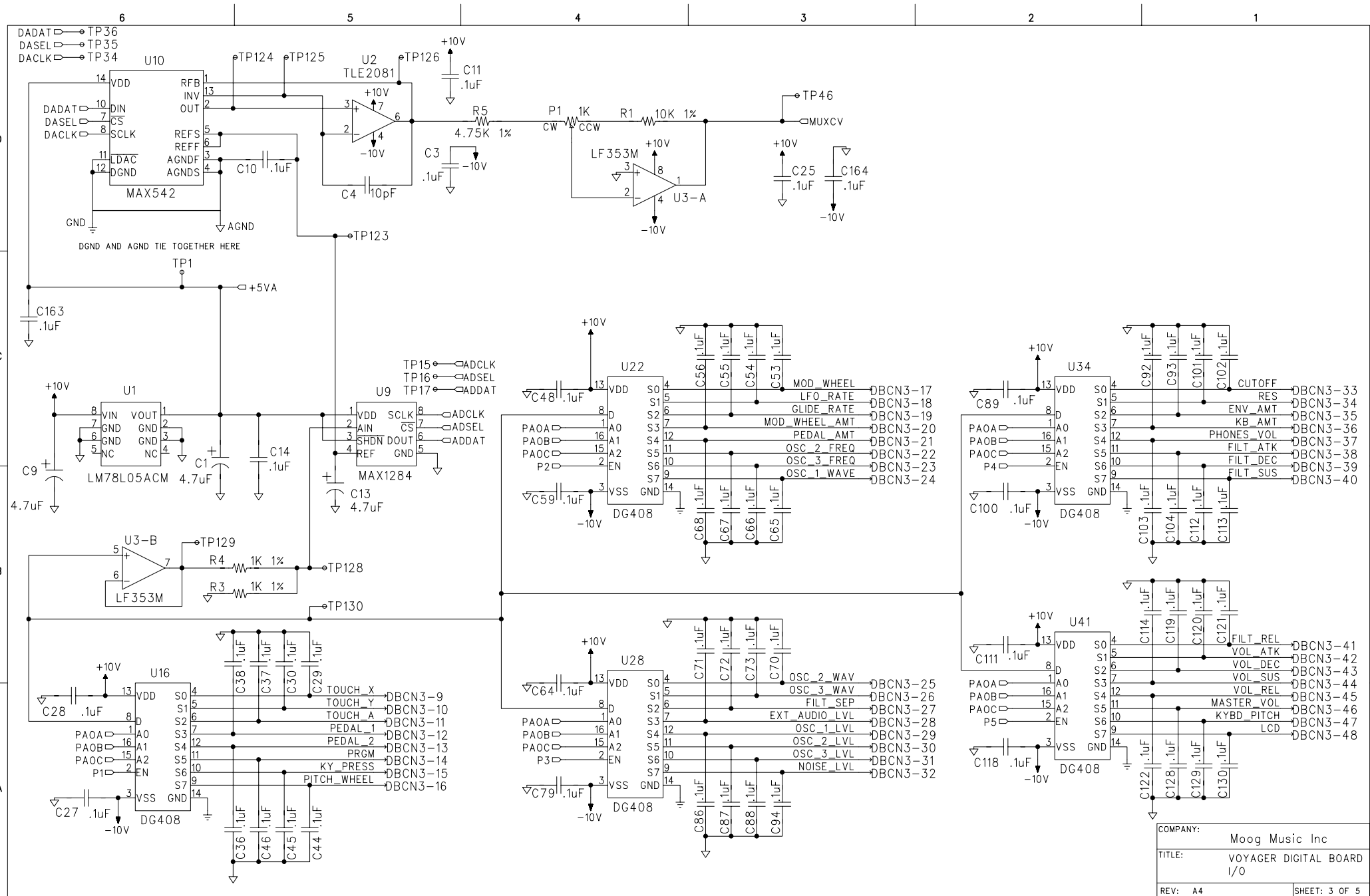

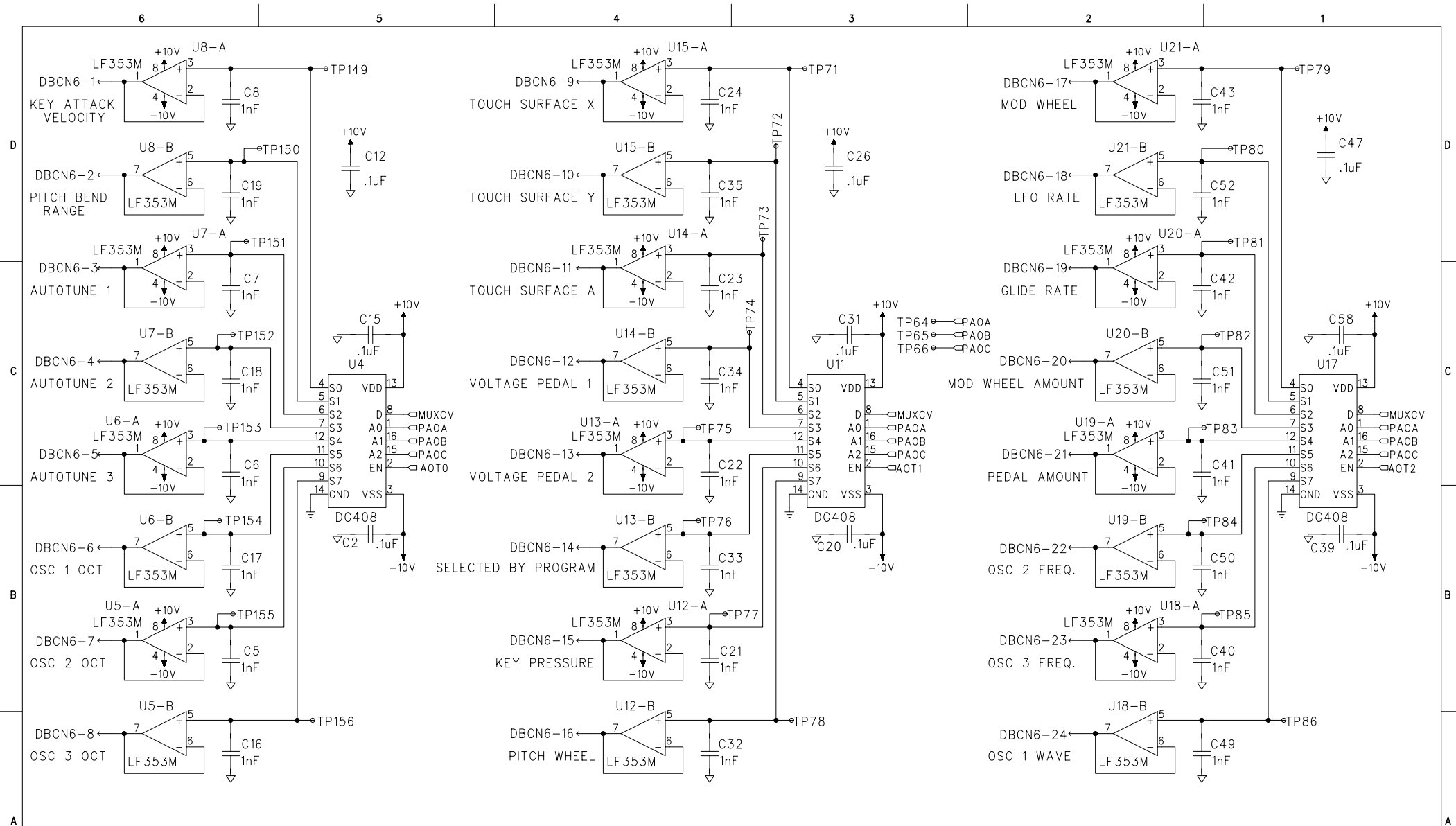

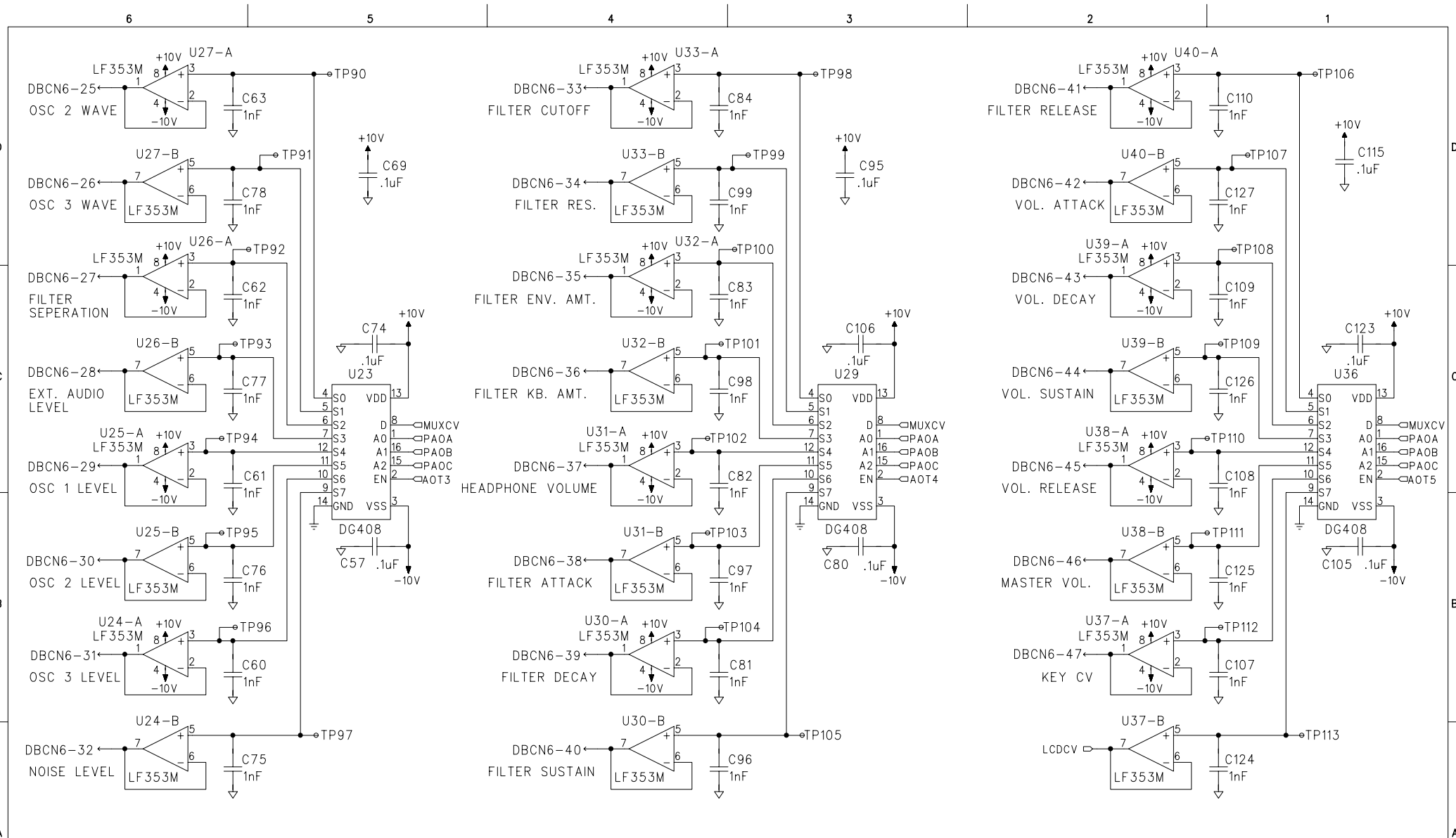

COMPANY:	Moog Music Inc
TITLE:	VOYAGER DIGITAL BOARD CV OUTPUTS
REV:	A4
SHEET:	5 OF 5

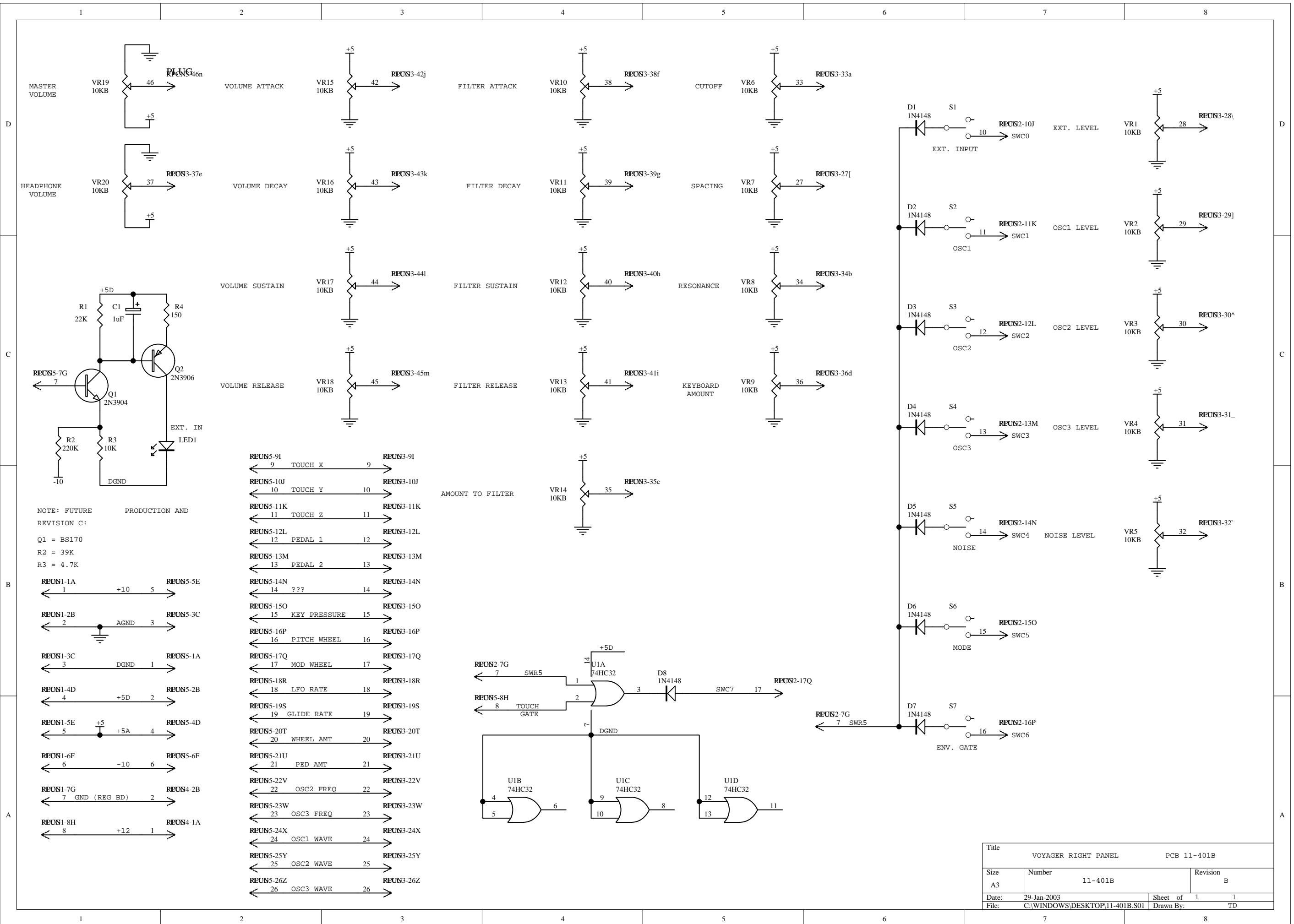

NOTE: FUTURE REVISION C:
 Q1 = BS170
 R2 = 39K
 R3 = 4.7K

- RECN5-9I 9 TOUCH X → RECN3-9I
- RECN5-10J 10 TOUCH Y → RECN3-10J
- RECN5-11K 11 TOUCH Z → RECN3-11K
- RECN5-12L 12 PEDAL 1 → RECN3-12L
- RECN5-13M 13 PEDAL 2 → RECN3-13M
- RECN5-14N 14 ??? → RECN3-14N
- RECN5-15O 15 KEY PRESSURE → RECN3-15O
- RECN5-16P 16 PITCH WHEEL → RECN3-16P
- RECN5-17Q 17 MOD WHEEL → RECN3-17Q
- RECN5-18R 18 LFO RATE → RECN3-18R
- RECN5-19S 19 GLIDE RATE → RECN3-19S
- RECN5-20T 20 WHEEL AMT → RECN3-20T
- RECN5-21U 21 PED AMT → RECN3-21U
- RECN5-22V 22 OSC2 FREQ → RECN3-22V
- RECN5-23W 23 OSC3 FREQ → RECN3-23W
- RECN5-24X 24 OSC1 WAVE → RECN3-24X
- RECN5-25Y 25 OSC2 WAVE → RECN3-25Y
- RECN5-26Z 26 OSC3 WAVE → RECN3-26Z

Title		VOYAGER RIGHT PANEL PCB 11-401B	
Size	Number	Revision	
A3	11-401B	B	
Date:	29-Jan-2003	Sheet of	1 1
File:	C:\WINDOWS\DESKTOP\11-401B.S01	Drawn By:	TD

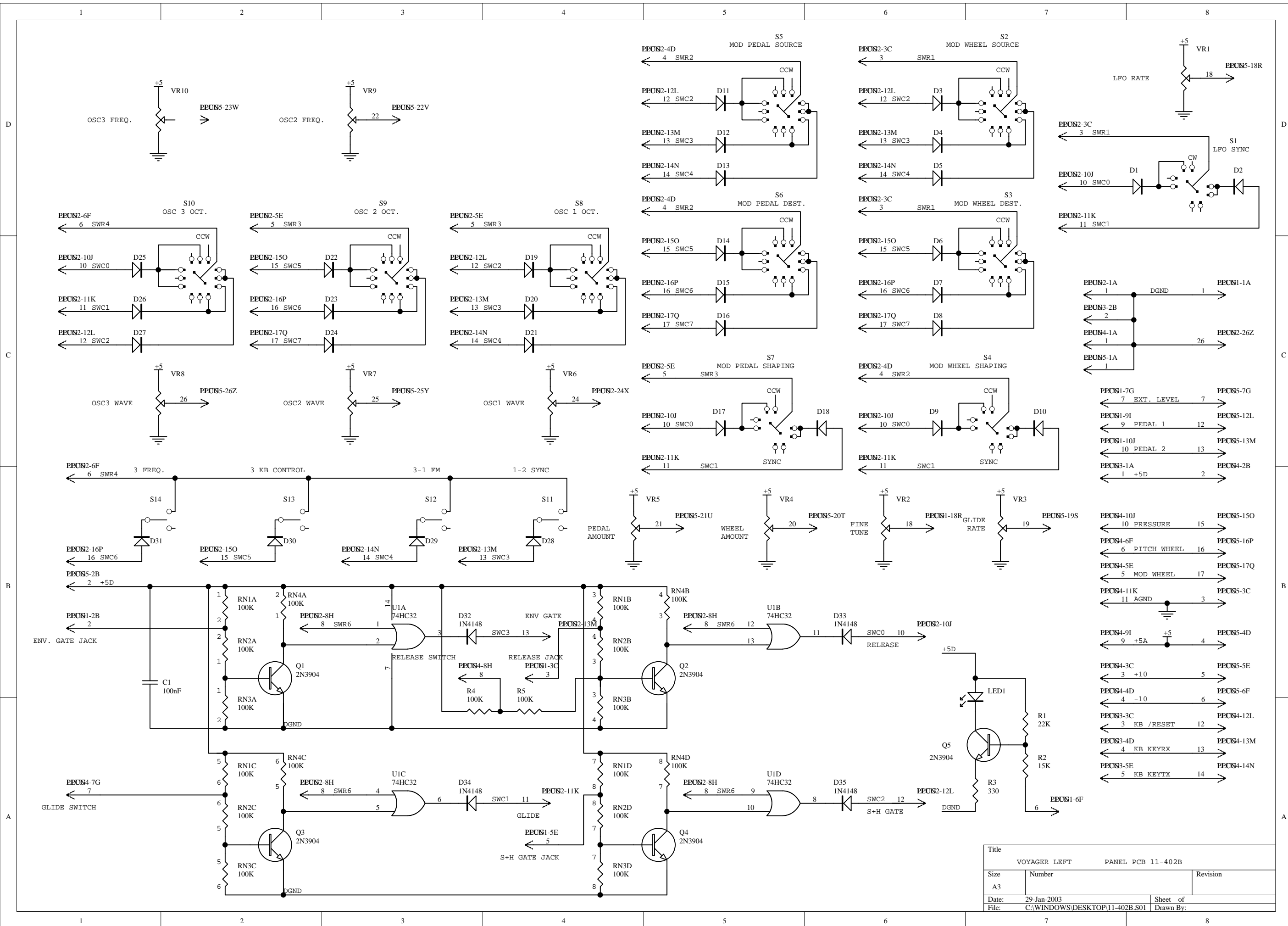

Title		VOYAGER LEFT PANEL PCB 11-402B	
Size	A3	Number	
Date:	29-Jan-2003	Sheet of	
File:	C:\WINDOWS\DESKTOP\11-402B.S01	Drawn By:	

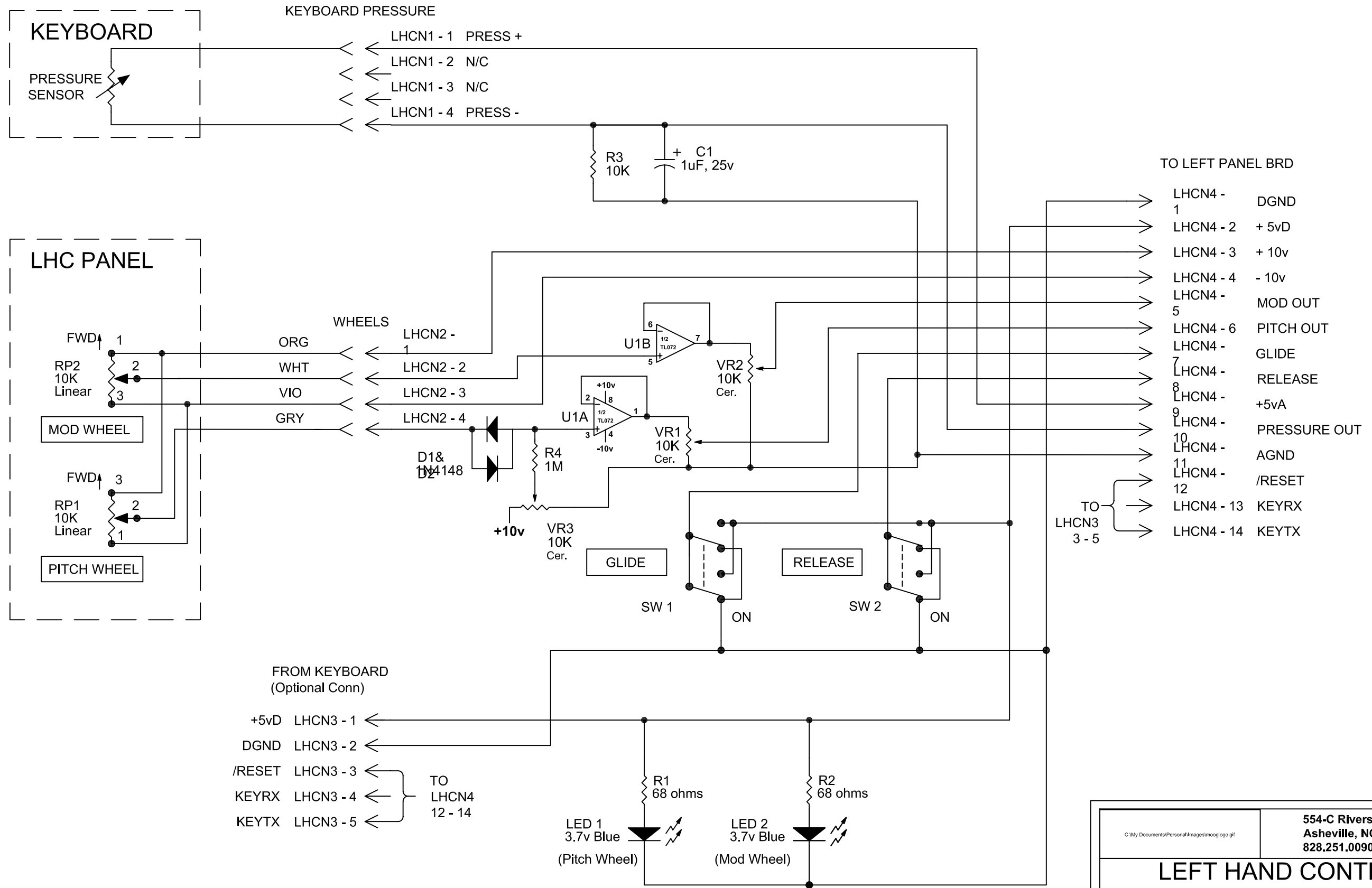

C:\My Documents\Personal\Images\mooglogo.gif		554-C Riverside Drive Asheville, NC 28801 828.251.0090 828.254.6233 FAX	
LEFT HAND CONTROLLER SCHEMATIC (11-403A)			
DWG #: 411403P		PRODUCT NAME: minimog VOYAGER	
DRAWN BY: AJW		APPROVED BY: RAM	SHEET: 1 of 1
DATE: 22 MAR 2002		DATE APPROVED: 26 MAR 2002	REV: -

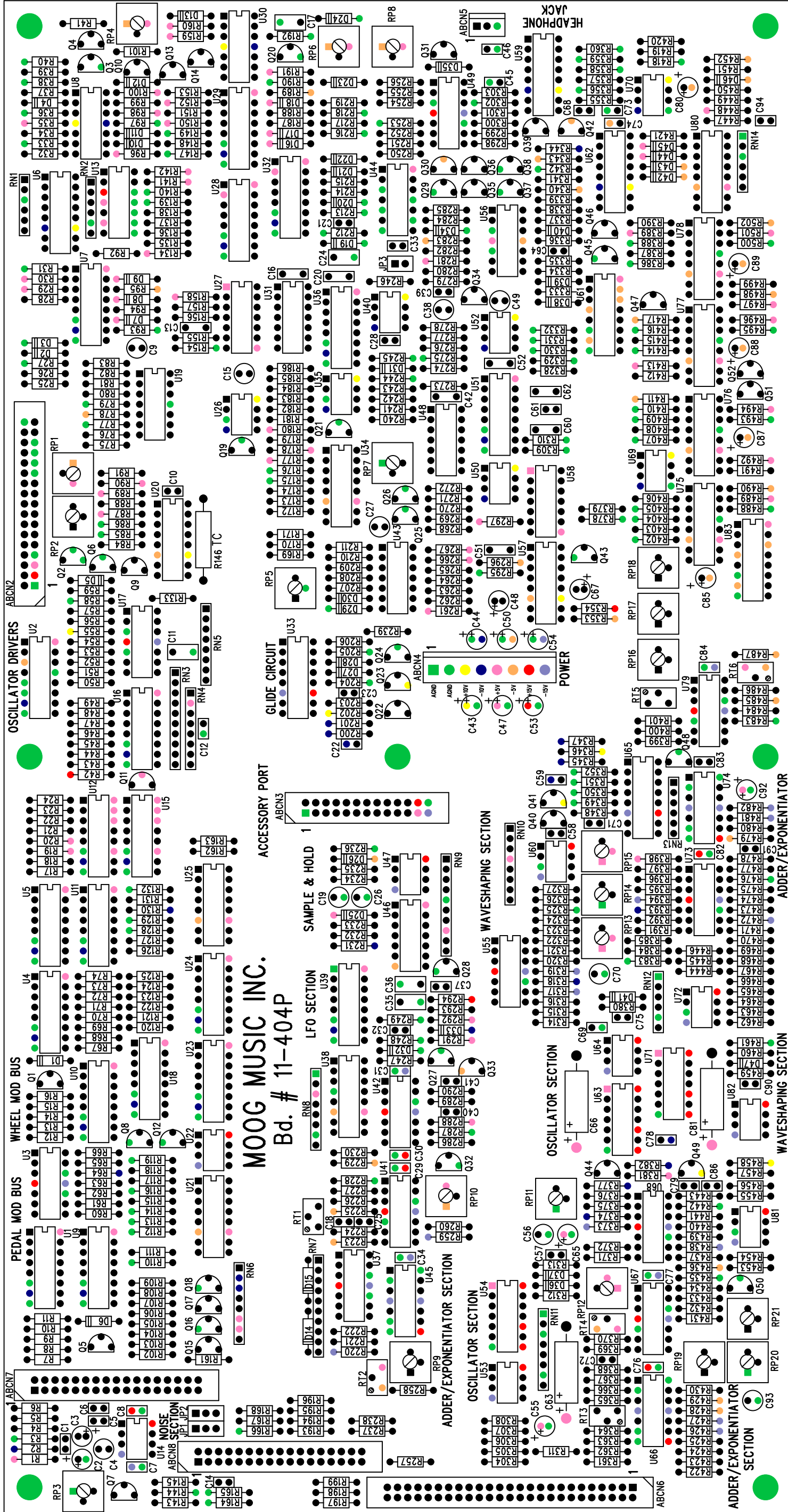

MOOG MUSIC INC.
Bd. # 11-404P

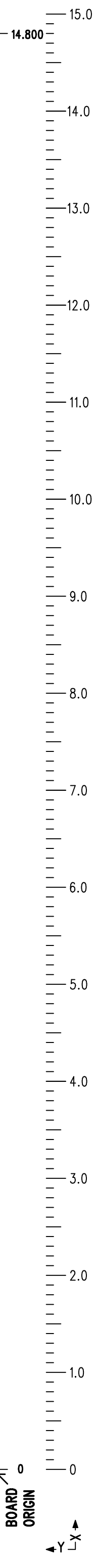

7.700

7.0

6.0

5.0

4.0

3.0

2.0

1.0

0

BOARD ORIGIN

Y
X

6

5

4

3

2

1

REVISION RECORD		
LTR	DESCRIPTION	BY

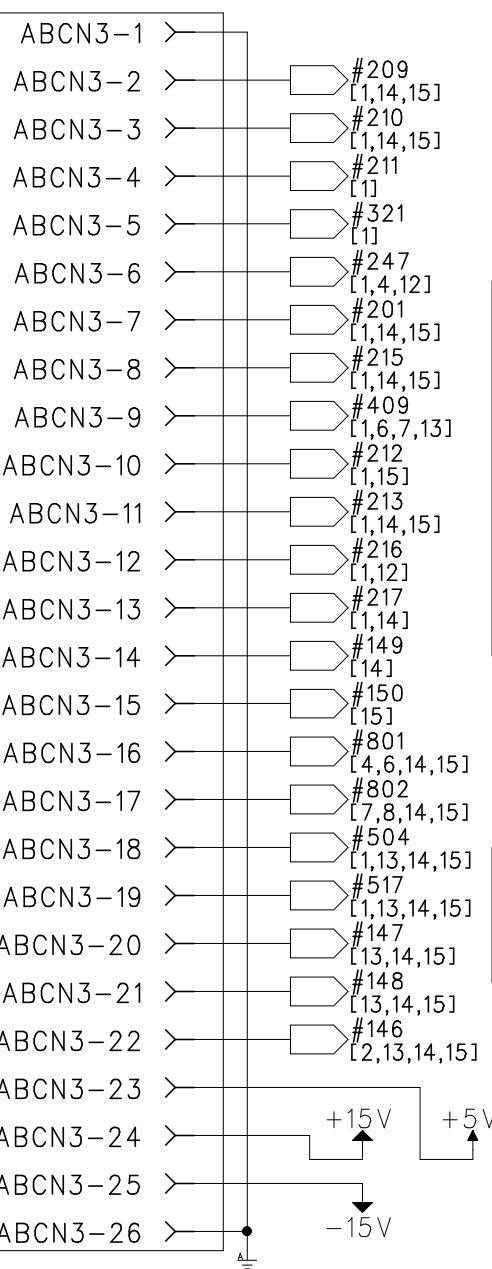
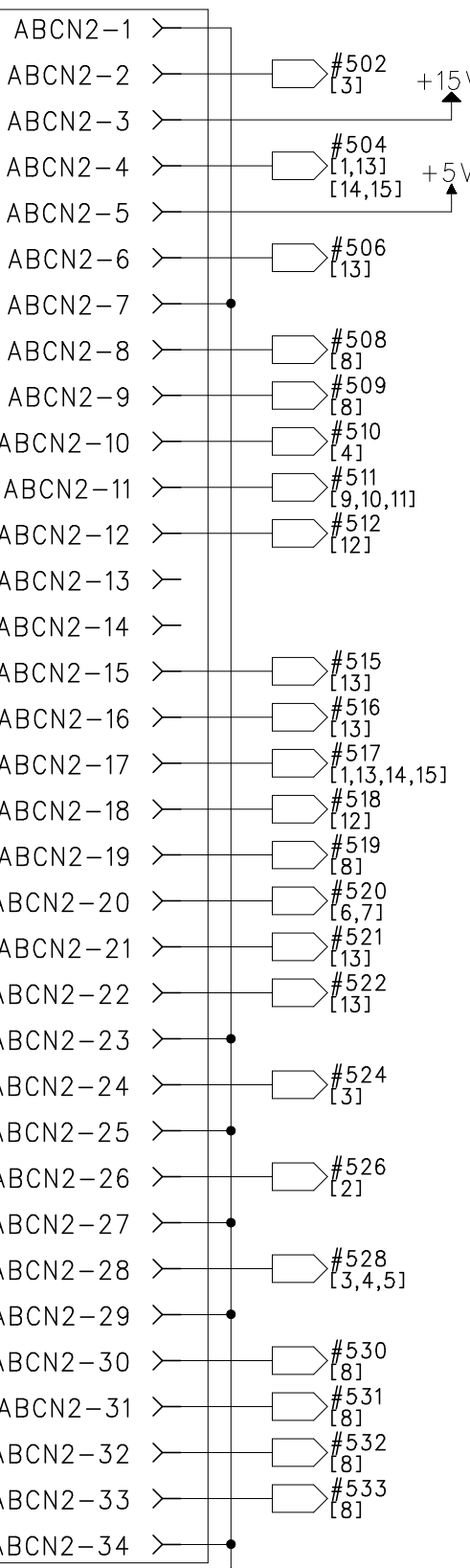
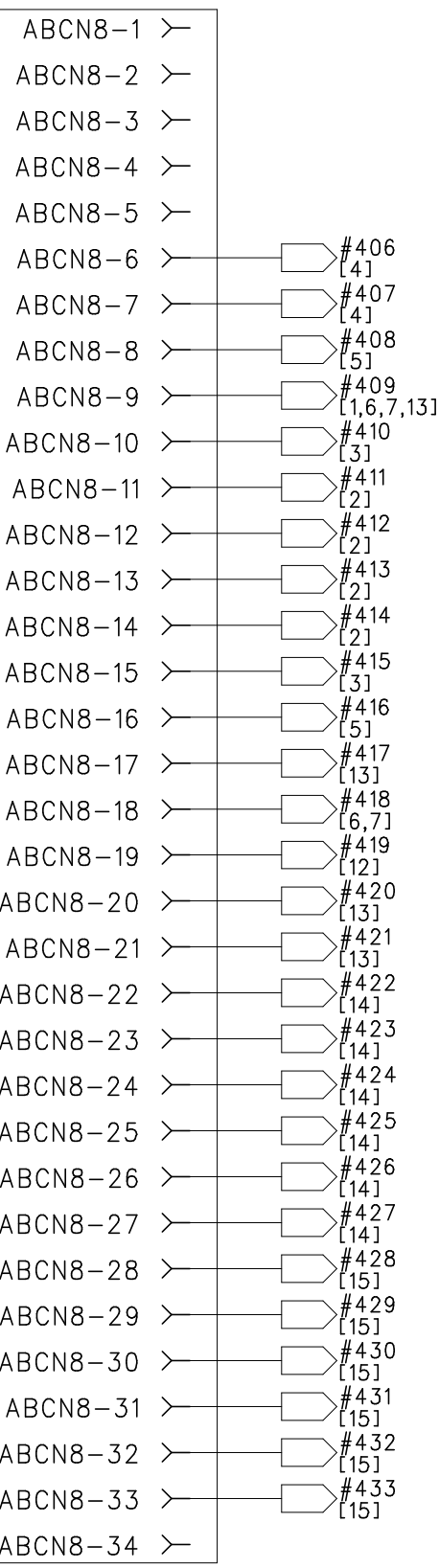
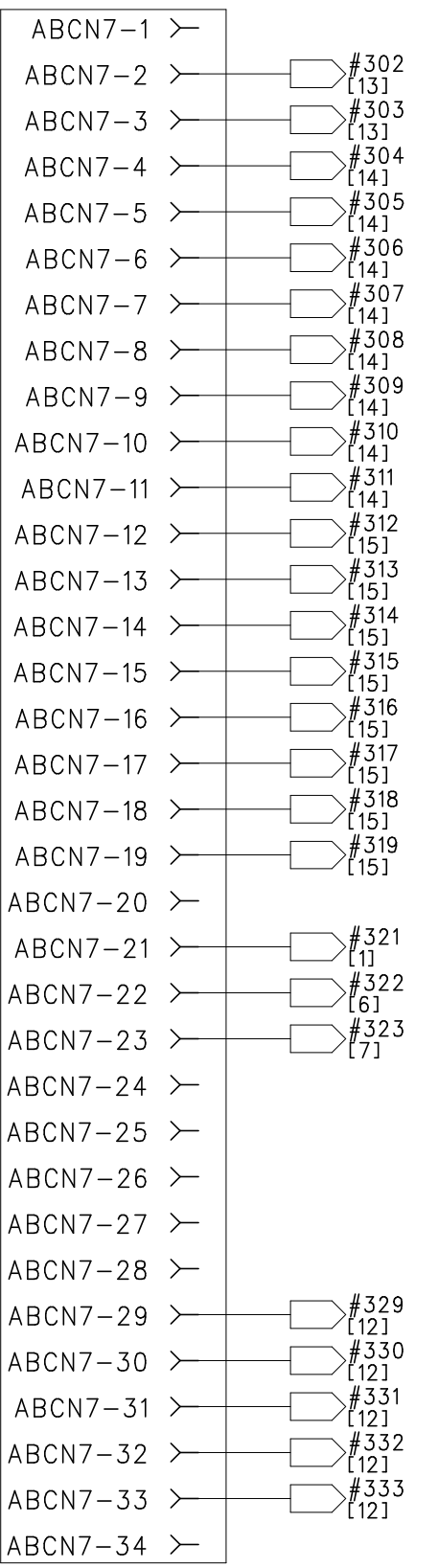
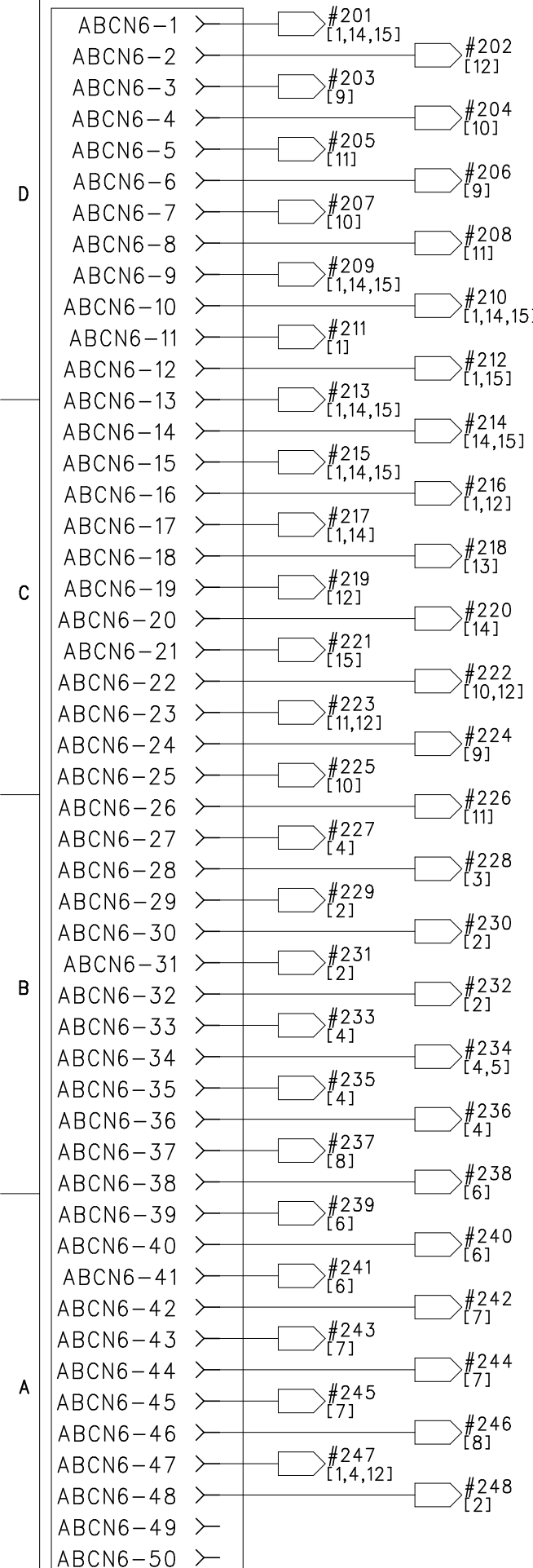

MOUNTING HOLES

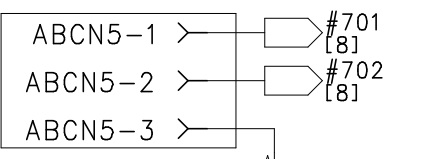
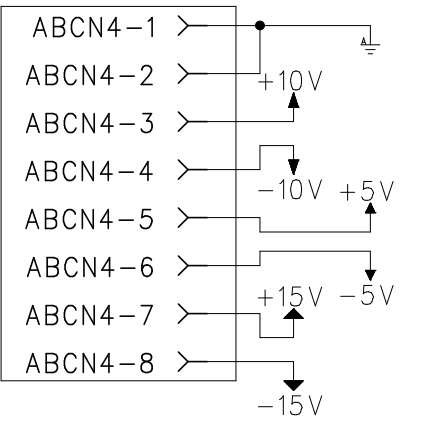
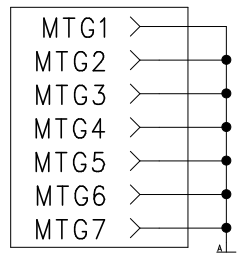

COMPANY: **Moog Music Inc.**

TITLE: **ANALOG BOARD; 11-404P**

DRAWN: J. Mathews	DATED: 7/24/2002	CODE:	SIZE:	DRAWING NO:	REV:
CHECKED: B. Moog	DATED: 7/25/2002	D		JN10759.SCH	
QUALITY CONTROL: S. Region	DATED: 7/25/2002				
RELEASED: J. Mathews	DATED: 7/26/2002	SCALE: NTS	SHEET: 1 OF 15		

D

C

B

A

D

C

B

A

Mixer

REVISION RECORD		
LTR	DESCRIPTION	BY

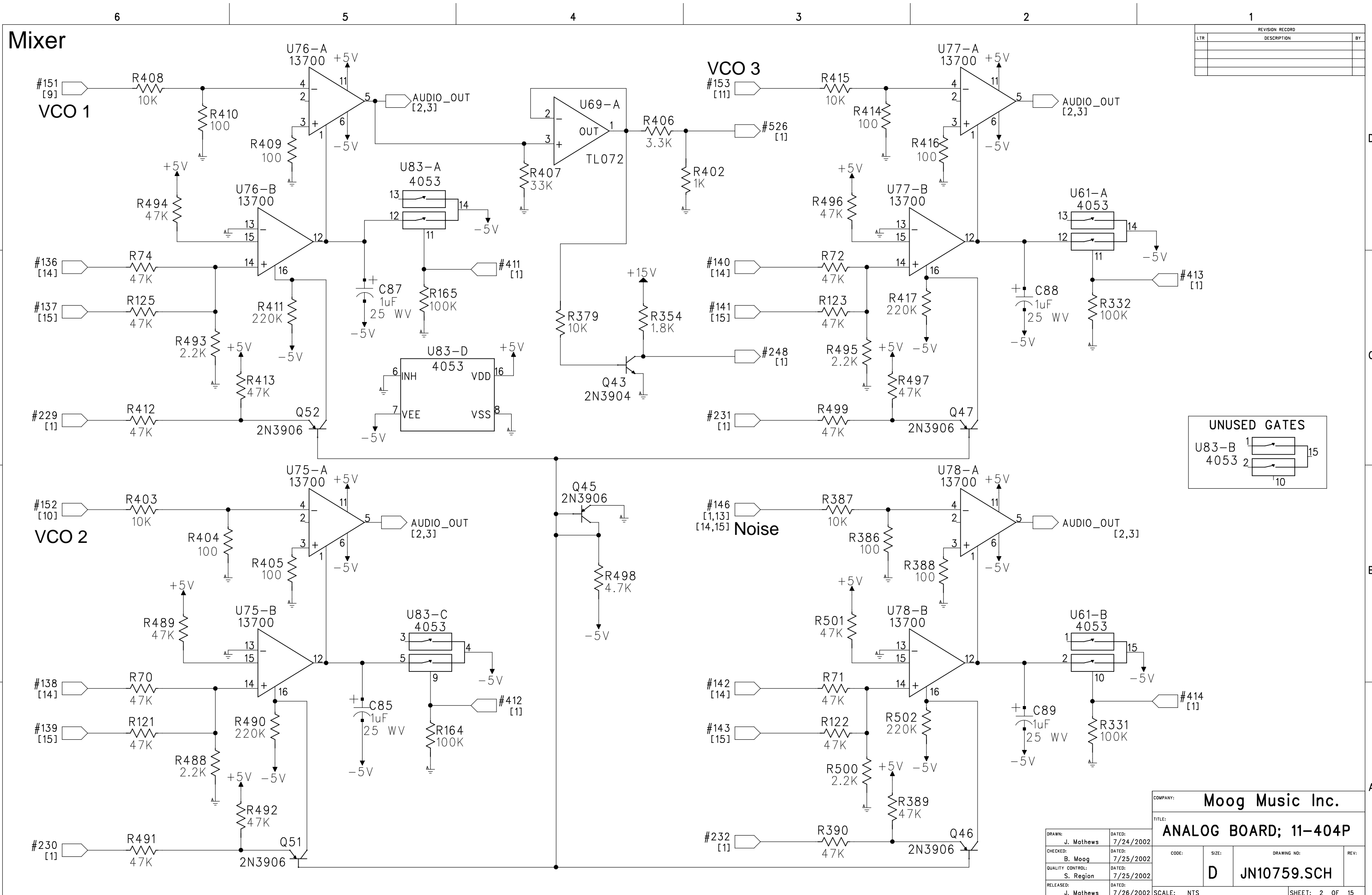

UNUSED GATES

U83-B
4053

DRAWN: J. Mathews		DATED: 7/24/2002		COMPANY: Moog Music Inc.	
CHECKED: B. Moog		DATED: 7/25/2002		TITLE: ANALOG BOARD; 11-404P	
QUALITY CONTROL: S. Region		DATED: 7/25/2002		CODE: D	SIZE: JN10759.SCH
RELEASED: J. Mathews		DATED: 7/26/2002		SCALE: NTS	SHEET: 2 OF 15

Audio IN (compressor & level)

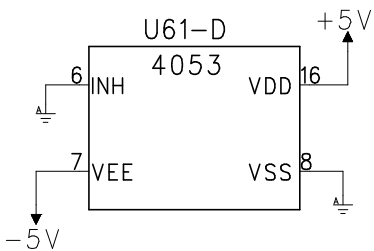
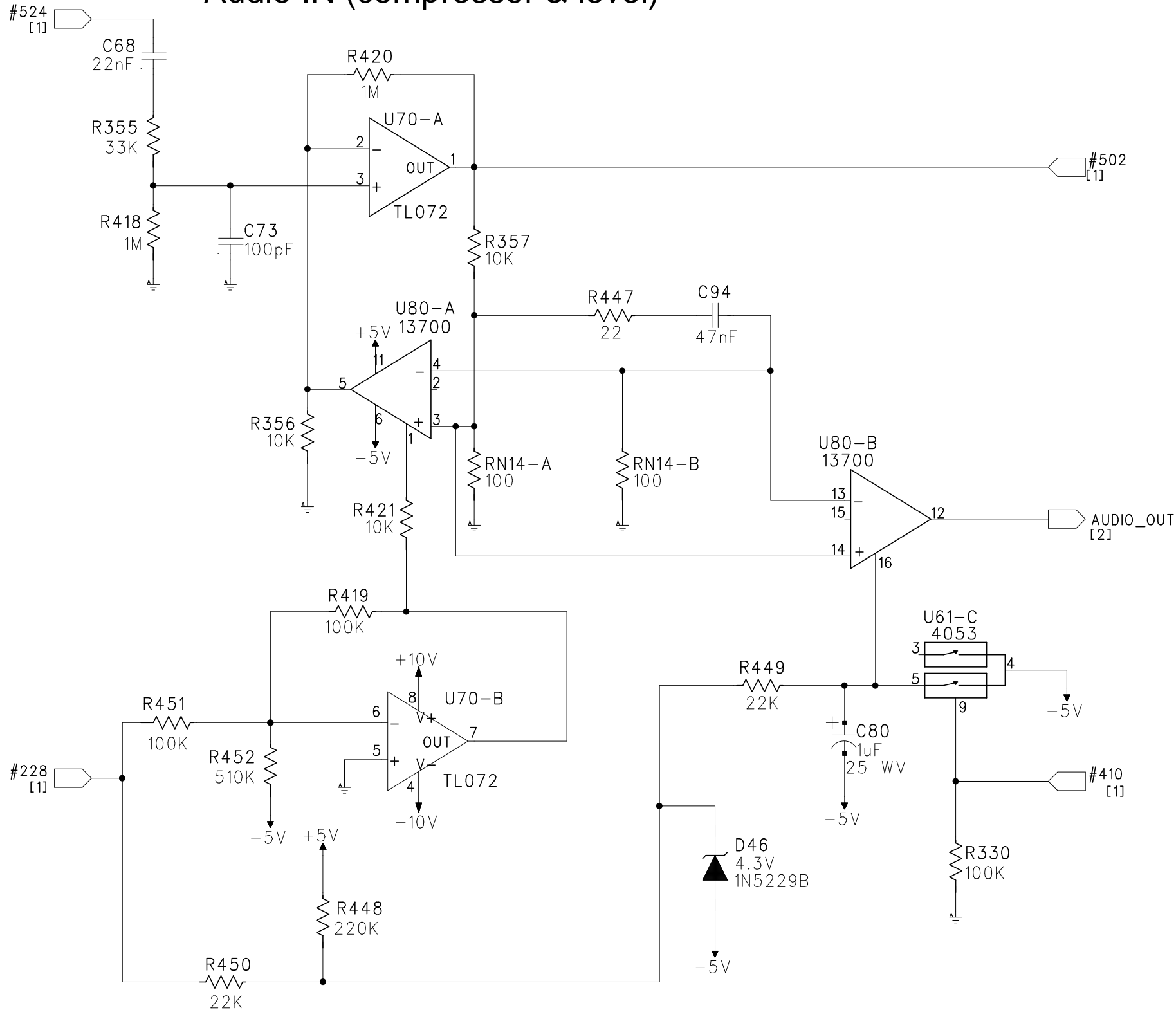

UNUSED GATES



FILTER COUPLING CIRCUIT

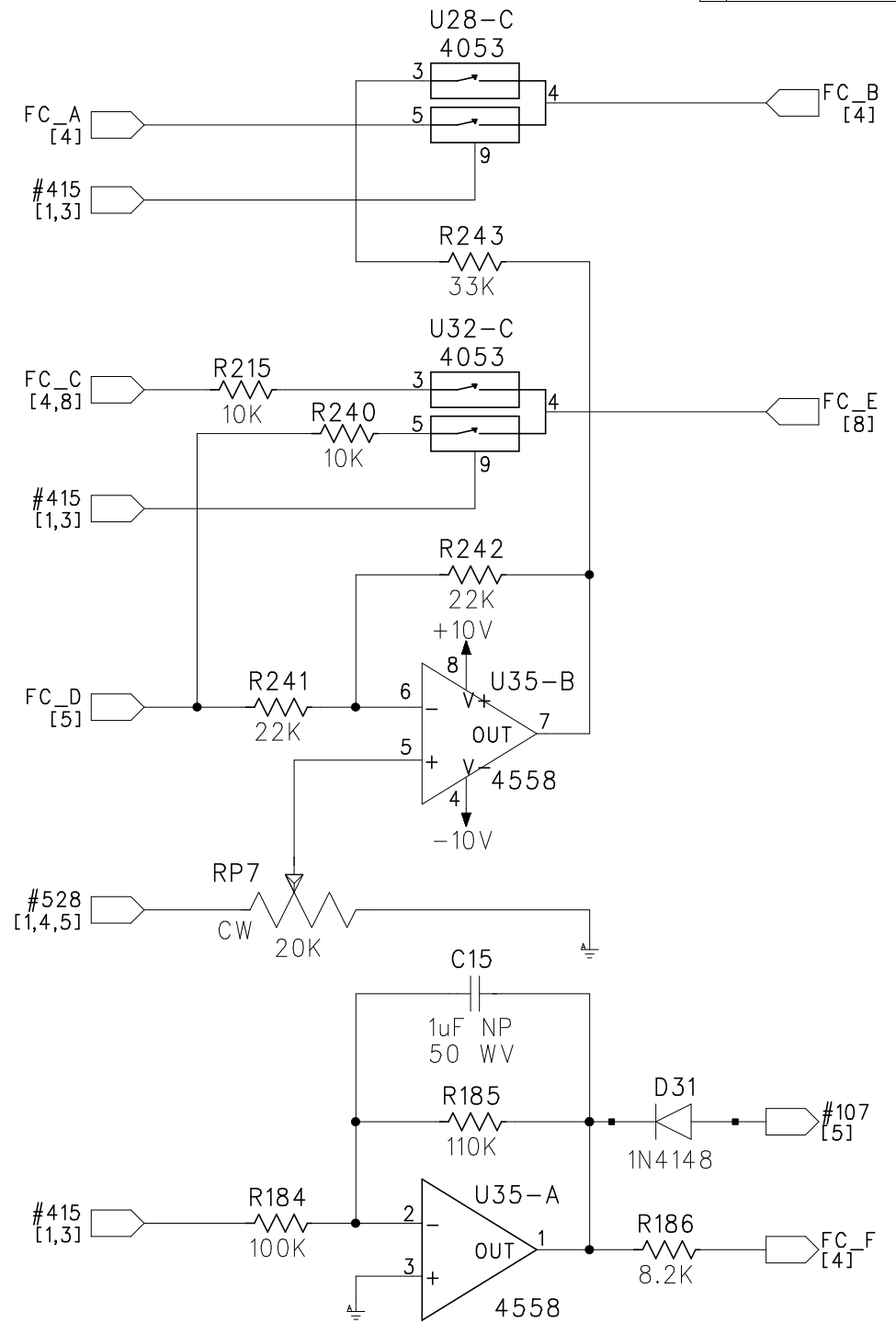

REVISION RECORD		
LTR	DESCRIPTION	BY

COMPANY: Moog Music Inc.

TITLE: ANALOG BOARD; 11-404P

DRAWN: J. Mathews	DATED: 7/24/2002
CHECKED: B. Moog	DATED: 7/25/2002
QUALITY CONTROL: S. Region	DATED: 7/25/2002
RELEASED: J. Mathews	DATED: 7/26/2002

CODE:	SIZE:	DRAWING NO:	REV:
		D	JN10759.SCH
SCALE: NTS		SHEET: 3 OF 15	

LPF Section

6 5 4 3 2 1

REVISION RECORD	
DESCRIPTION	BY

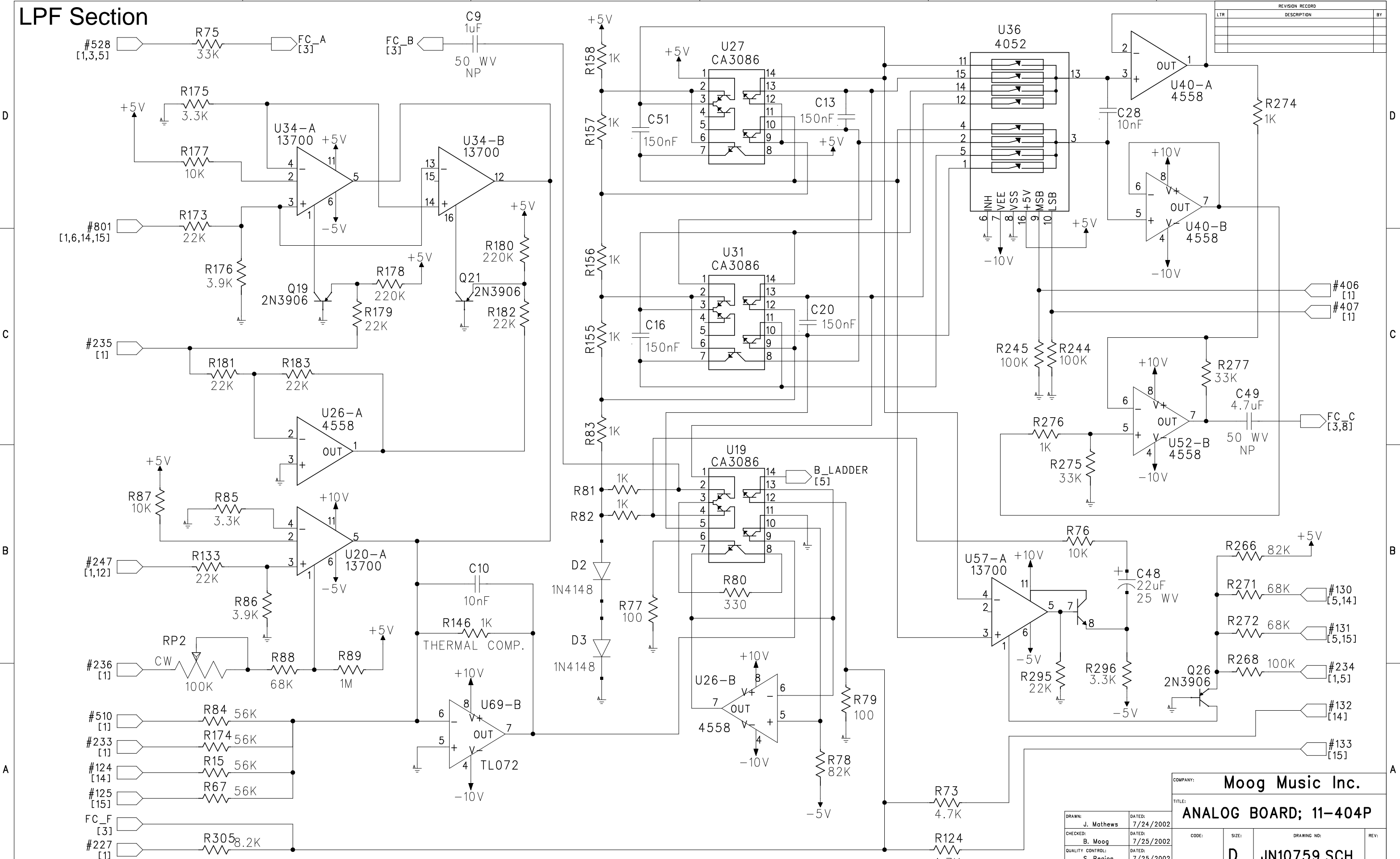

COMPANY: **Moog Music Inc.**

TITLE: **ANALOG BOARD; 11-404P**

DRAWN: J. Mathews	DATED: 7/24/2002	CODE: D	SIZE: NTS	DRAWING NO: JN10759.SCH	REV: 1
CHECKED: B. Moog	DATED: 7/25/2002	SHEET: 4 OF 15			
QUALITY CONTROL: S. Region	DATED: 7/25/2002				
RELEASED: J. Mathews	DATED: 7/26/2002				

6

5

4

3

2

1

REVISION RECORD		
LTR	DESCRIPTION	BY

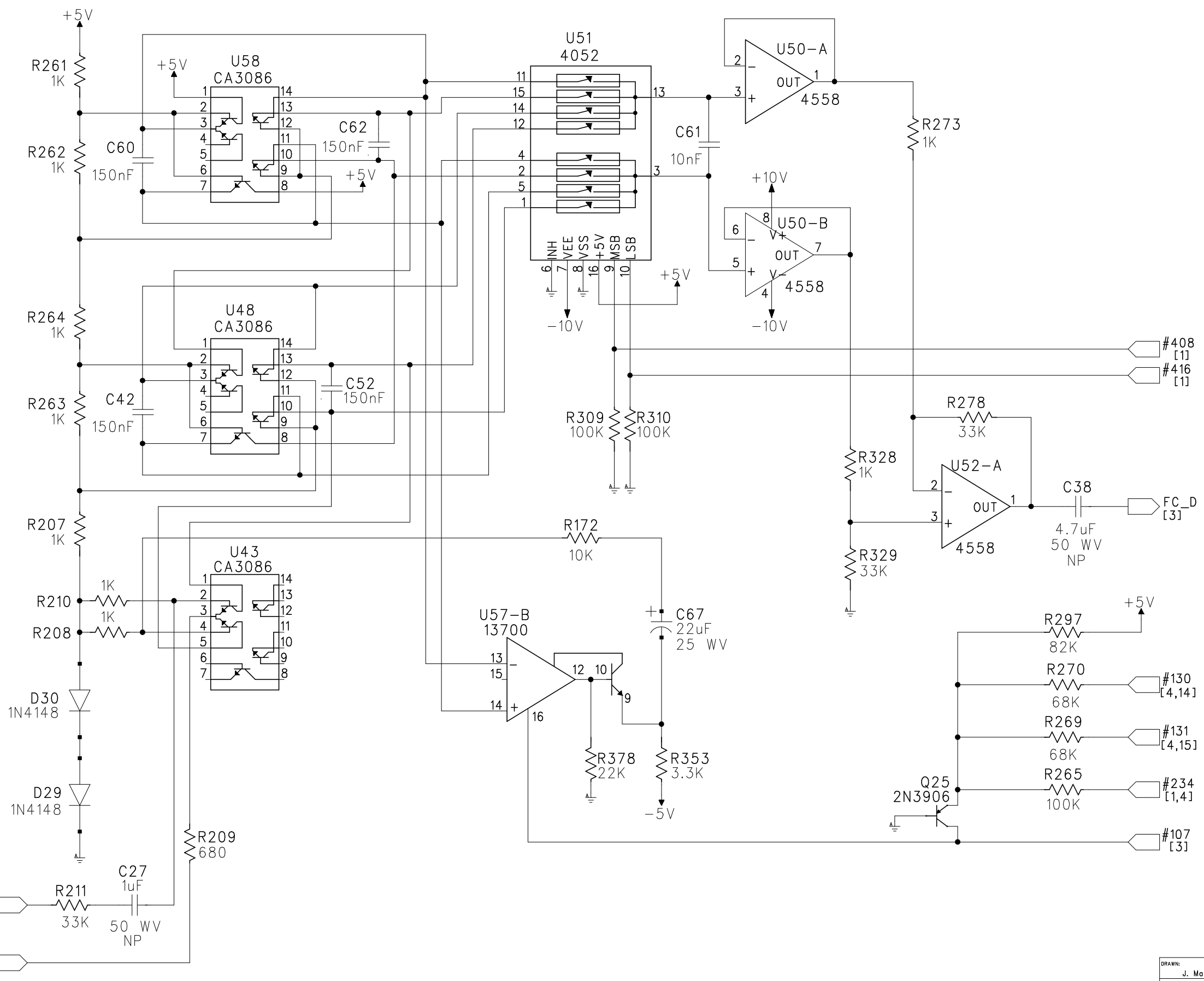

COMPANY: **Moog Music Inc.**

TITLE: **ANALOG BOARD; 11-404P**

DRAWN: J. Mathews	DATED: 7/24/2002	CODE:	SIZE:	DRAWING NO:	REV:
CHECKED: B. Moog	DATED: 7/25/2002	D JN10759.SCH			
QUALITY CONTROL: S. Region	DATED: 7/25/2002				
RELEASED: J. Mathews	DATED: 7/26/2002	SCALE: NTS	SHEET: 5 OF 15		

DRAWN: J. Mathews	DATED: 7/24/2002
CHECKED: B. Moog	DATED: 7/25/2002
QUALITY CONTROL: S. Region	DATED: 7/25/2002
RELEASED: J. Mathews	DATED: 7/26/2002

D

C

B

A

D

C

B

A

VCF Envelope

REVISION RECORD		
LTR	DESCRIPTION	BY

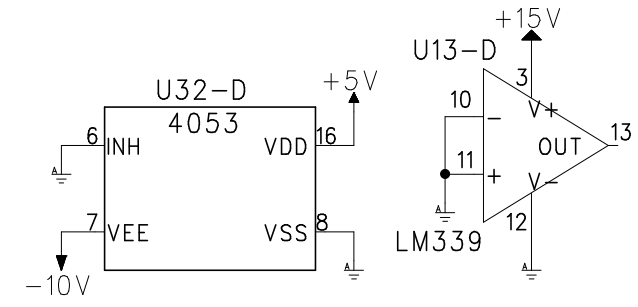
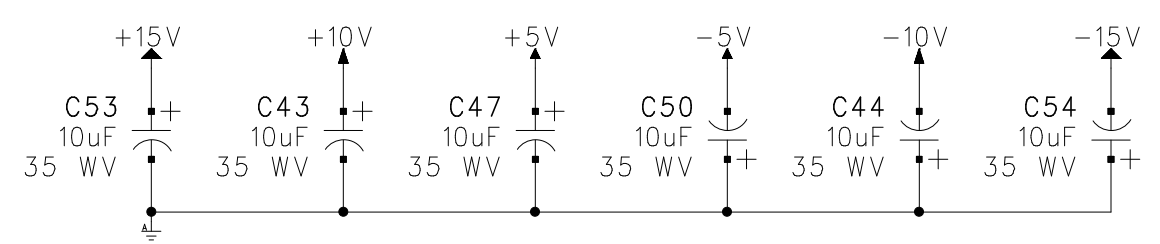
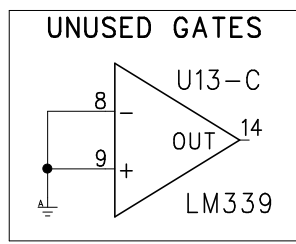
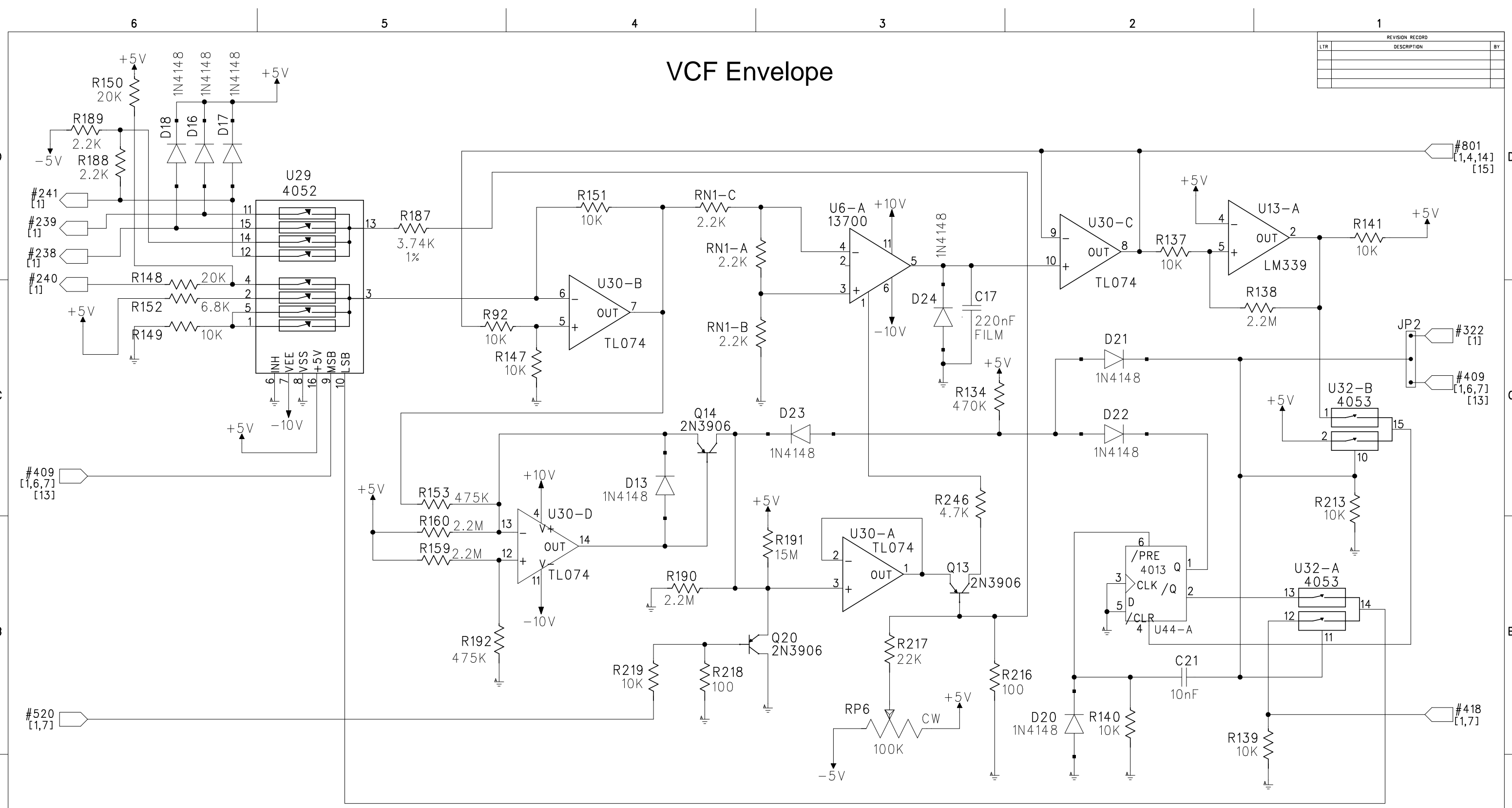

DRAWN: J. Mathews		DATED: 7/24/2002		COMPANY: Moog Music Inc.	
CHECKED: B. Moog		DATED: 7/25/2002		TITLE: ANALOG BOARD; 11-404P	
QUALITY CONTROL: S. Region		DATED: 7/25/2002		CODE: D	DRAWING NO: JN10759.SCH
RELEASED: J. Mathews		DATED: 7/26/2002		SCALE: NTS	SHEET: 6 OF 15

VCA Envelope

REVISION RECORD		
LTR	DESCRIPTION	BY

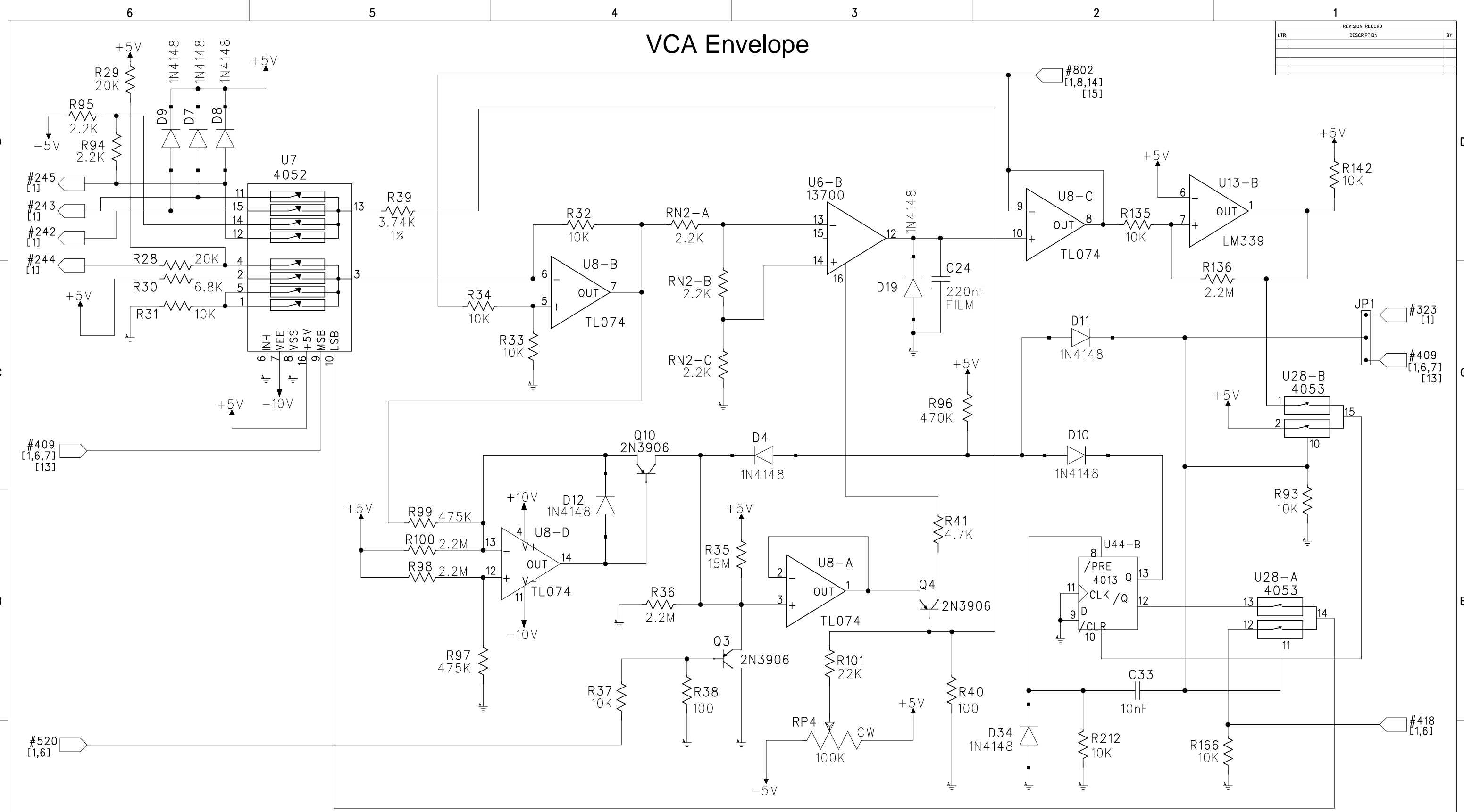

COMPANY:		Moog Music Inc.			
TITLE:		ANALOG BOARD; 11-404P			
DRAWN:	J. Mathews	DATED:	7/24/2002	CODE:	
CHECKED:	B. Moog	DATED:	7/25/2002	SIZE:	
QUALITY CONTROL:	S. Region	DATED:	7/25/2002	DRAWING NO:	D JN10759.SCH
RELEASED:	J. Mathews	DATED:	7/26/2002	REV:	
SCALE: NTS				SHEET: 7 OF 15	

Output Section (Master & Headphones)

REVISION RECORD		
LTR	DESCRIPTION	BY

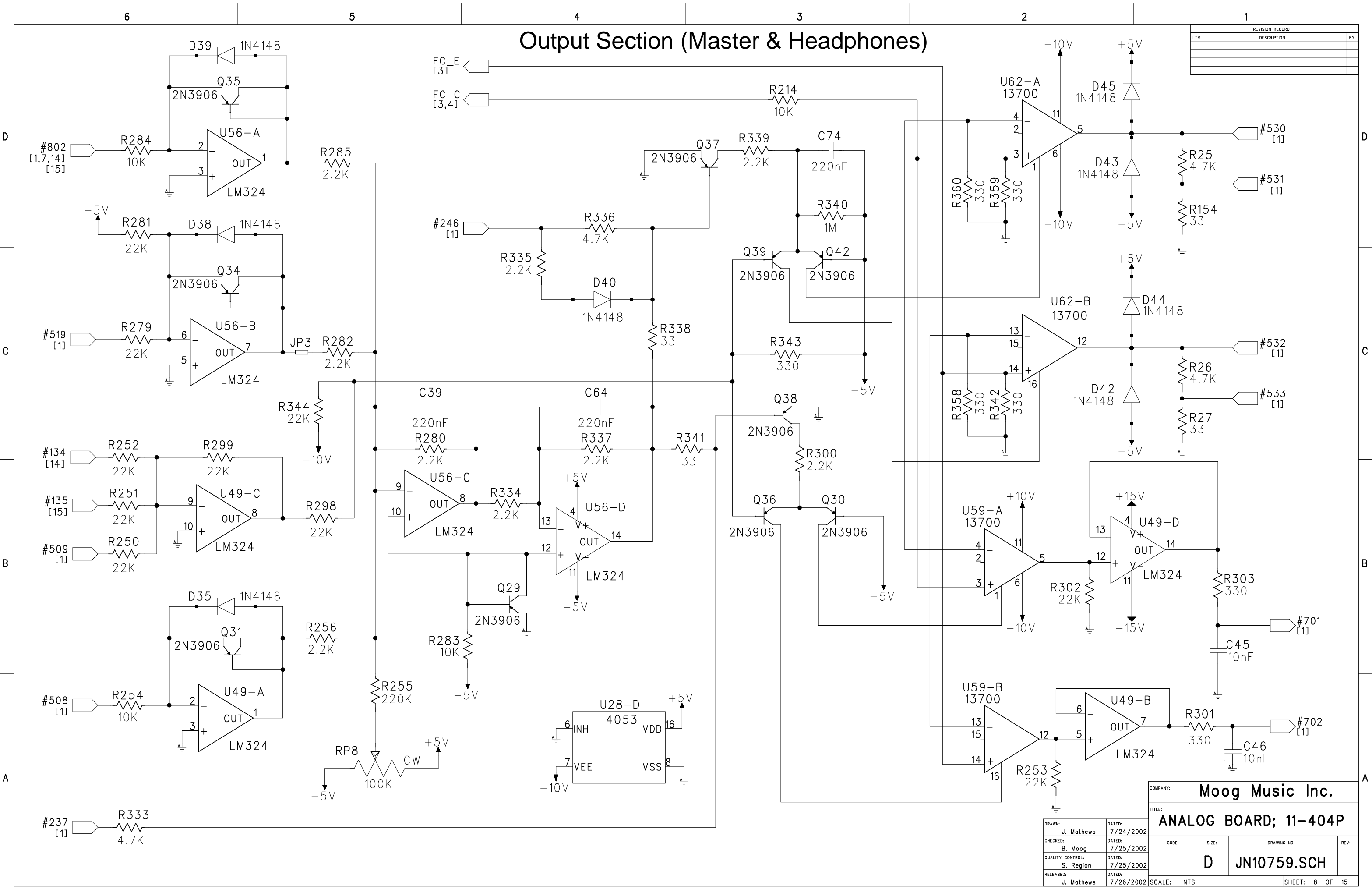

COMPANY:		Moog Music Inc.			
TITLE:		ANALOG BOARD; 11-404P			
DRAWN:	J. Mathews	DATED:	7/24/2002	CODE:	
CHECKED:	B. Moog	DATED:	7/25/2002	SIZE:	
QUALITY CONTROL:	S. Region	DATED:	7/25/2002	DRAWING NO:	D JN10759.SCH
RELEASED:	J. Mathews	DATED:	7/26/2002	SCALE:	NTS
					SHEET: 8 OF 15

VCO 1

ADDER/EXPONENTIATOR SECTION

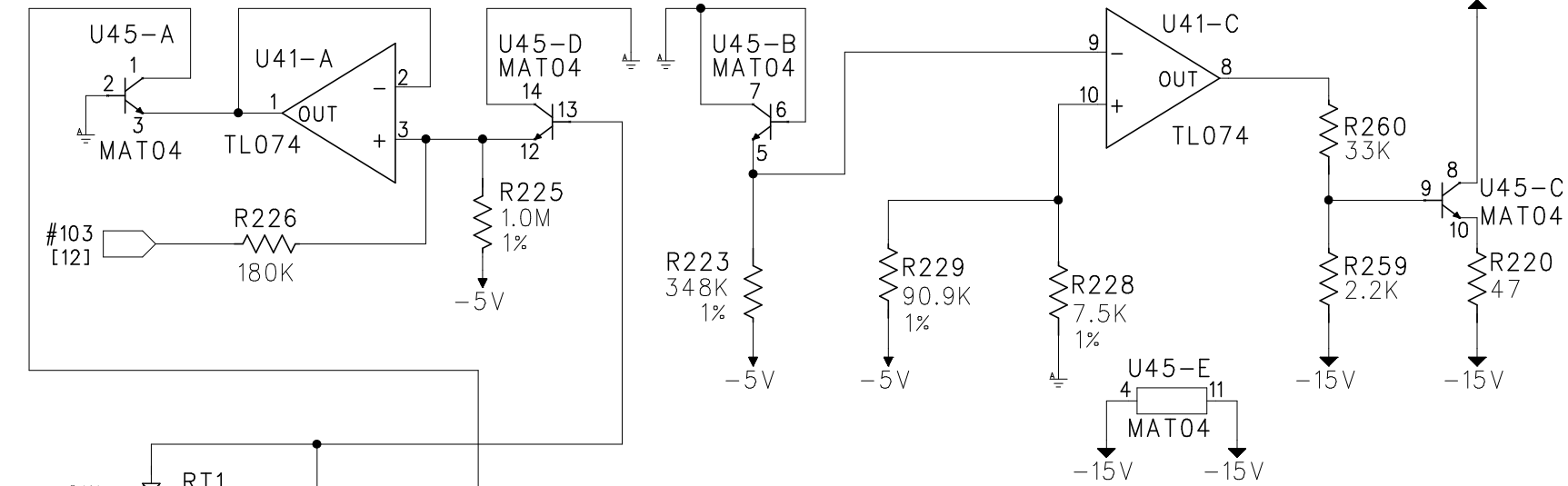

WAVESHAPING SECTION

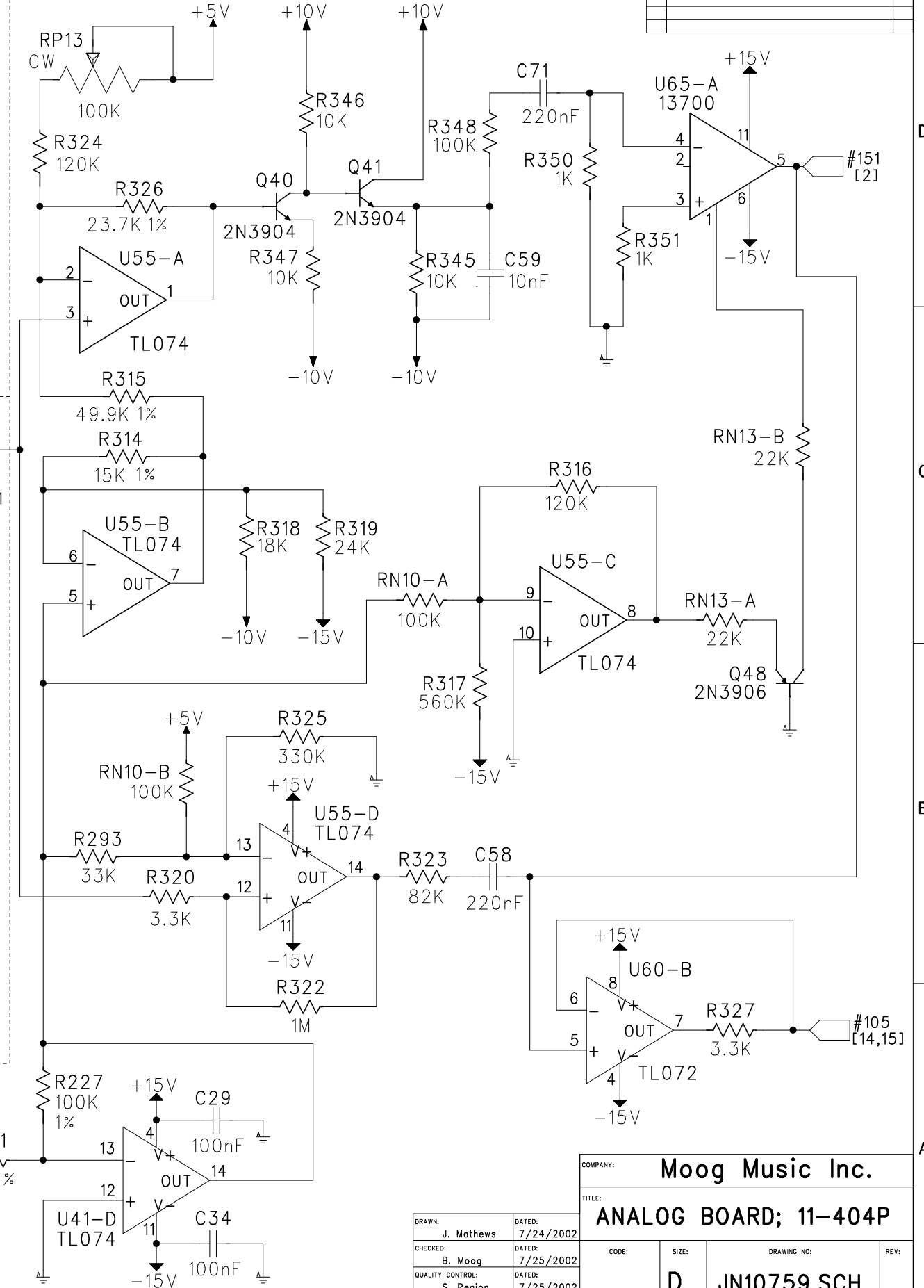

OSCILLATOR SECTION

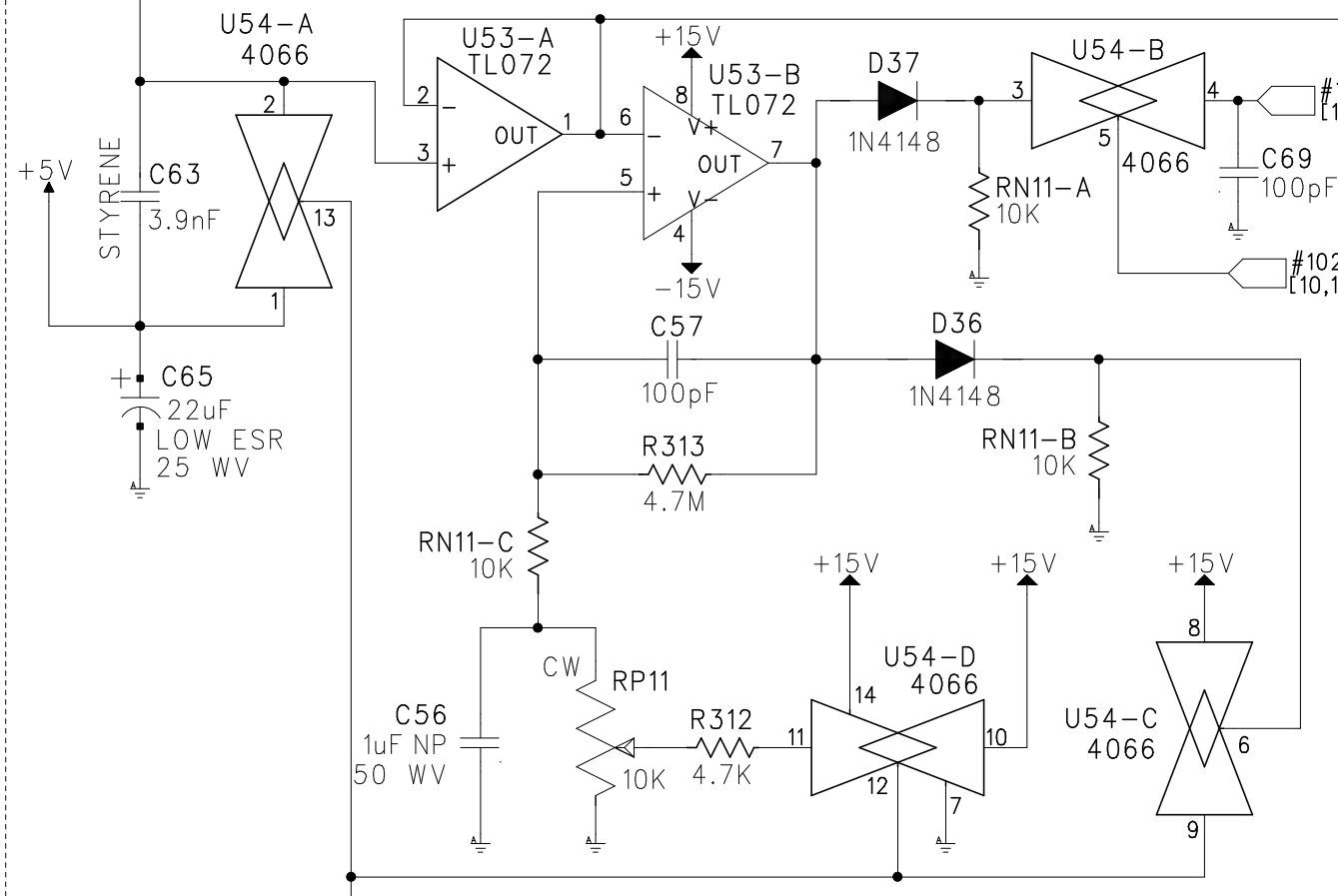

UNUSED GATES

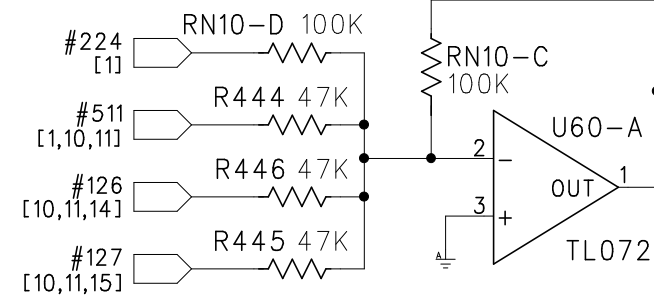

REVISION RECORD		
LTR	DESCRIPTION	BY

COMPANY: Moog Music Inc.		TITLE: ANALOG BOARD; 11-404P	
DRAWN: J. Mathews	DATED: 7/24/2002	CODE: D	SIZE: NTS
CHECKED: B. Moog	DATED: 7/25/2002	DRAWING NO: JN10759.SCH	REV: 9 OF 15
QUALITY CONTROL: S. Region	DATED: 7/25/2002	SHEET: 9 OF 15	
RELEASED: J. Mathews	DATED: 7/26/2002	SCALE: NTS	

VCO 2

ADDER/EXPONENTIATOR SECTION

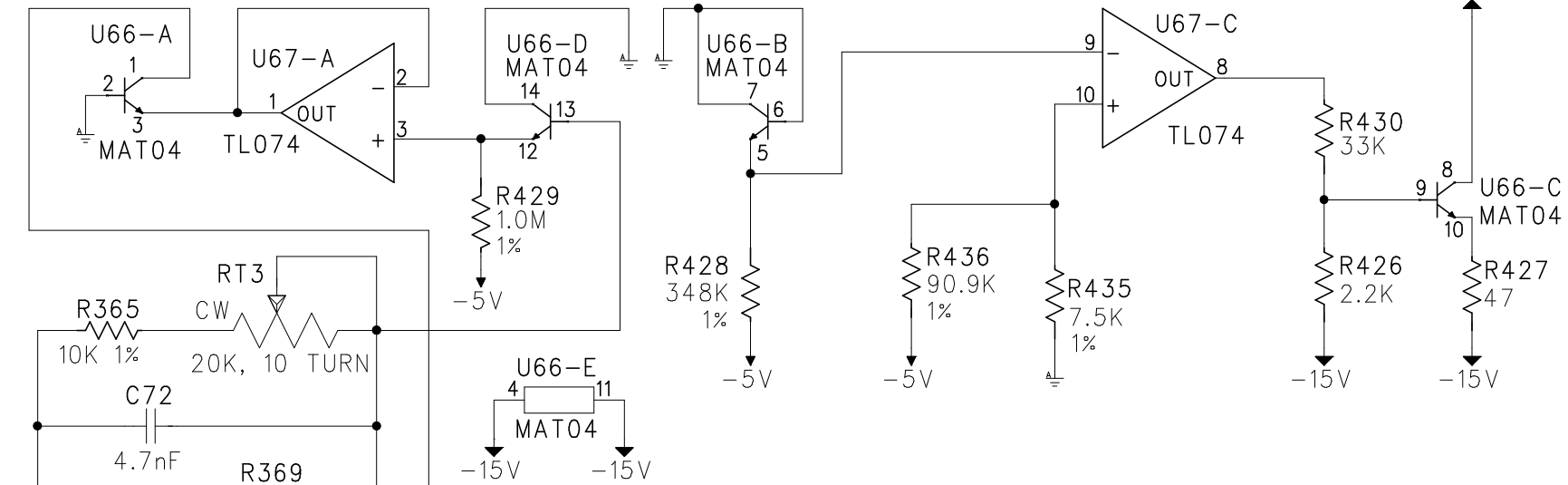

OSCILLATOR SECTION

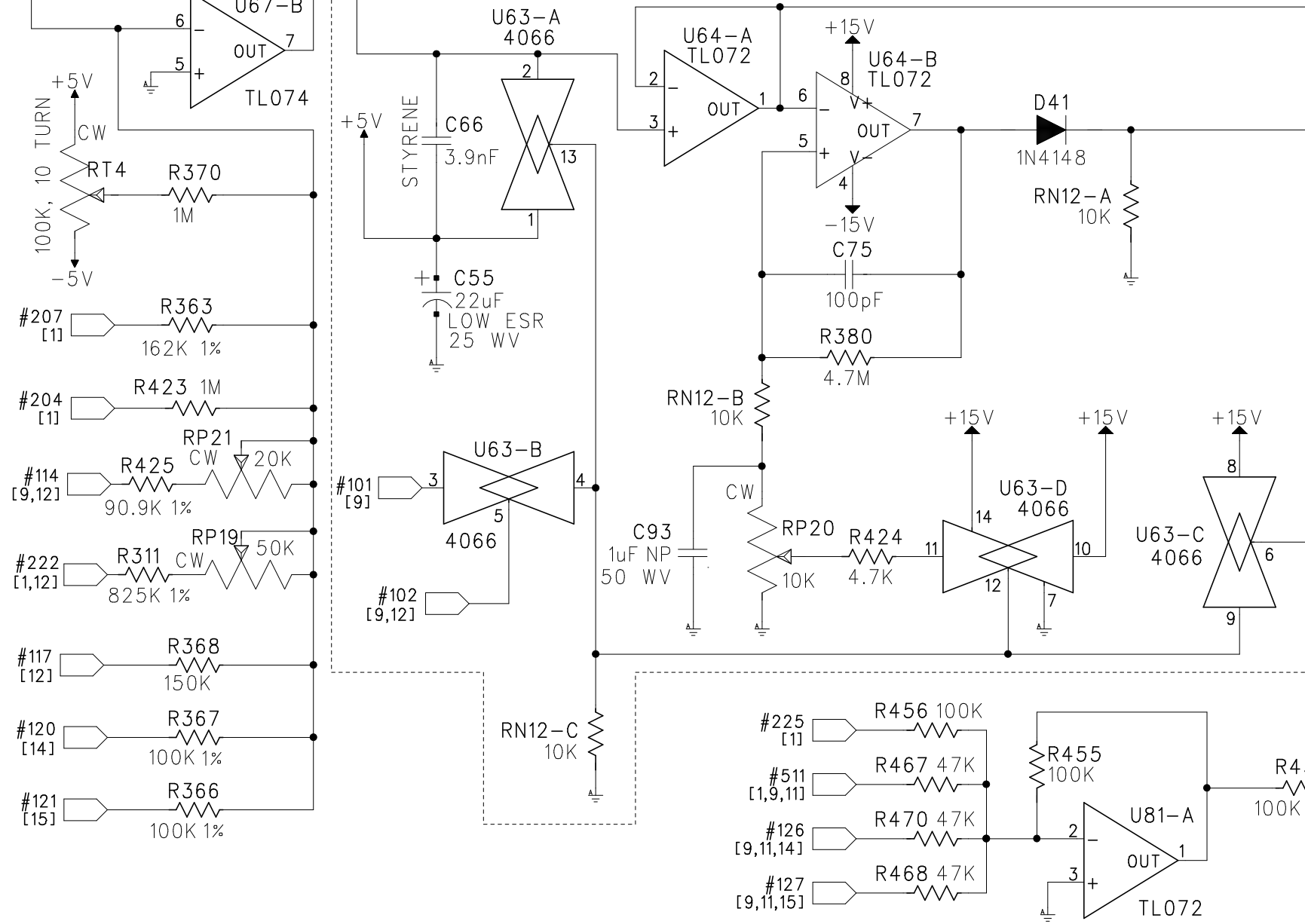

WAVESHAPING SECTION

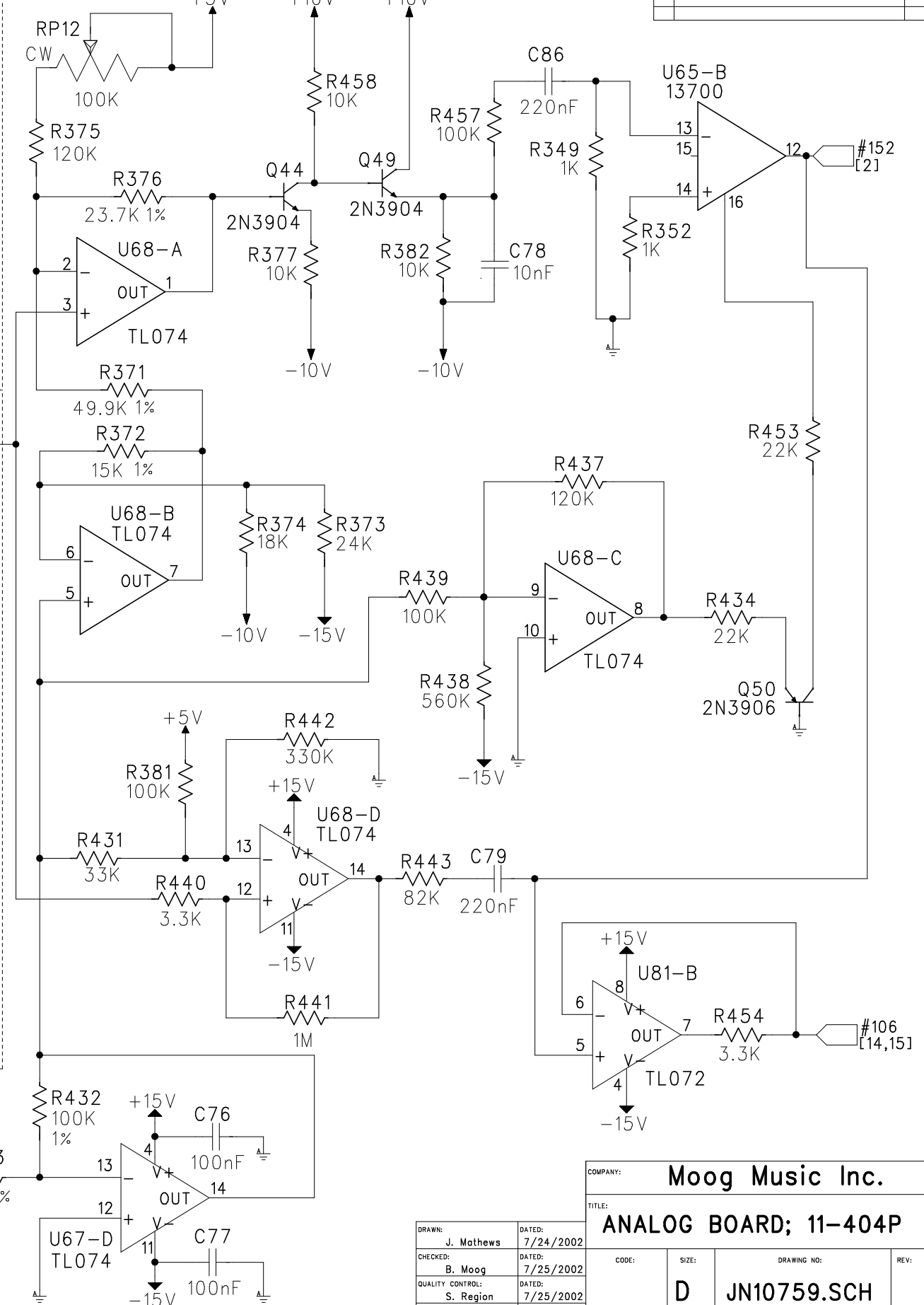

REVISION RECORD		
LTR	DESCRIPTION	BY

COMPANY: Moog Music Inc.	
TITLE: ANALOG BOARD; 11-404P	
DRAWN: J. Mathews	DATED: 7/24/2002
CHECKED: B. Moog	DATED: 7/25/2002
QUALITY CONTROL: S. Region	DATED: 7/25/2002
RELEASED: J. Mathews	DATED: 7/26/2002
CODE: D	SIZE: NTS
DRAWING NO: JN10759.SCH	REV: 10 OF 15

VCO 3

ADDER/EXPONENTIATOR SECTION

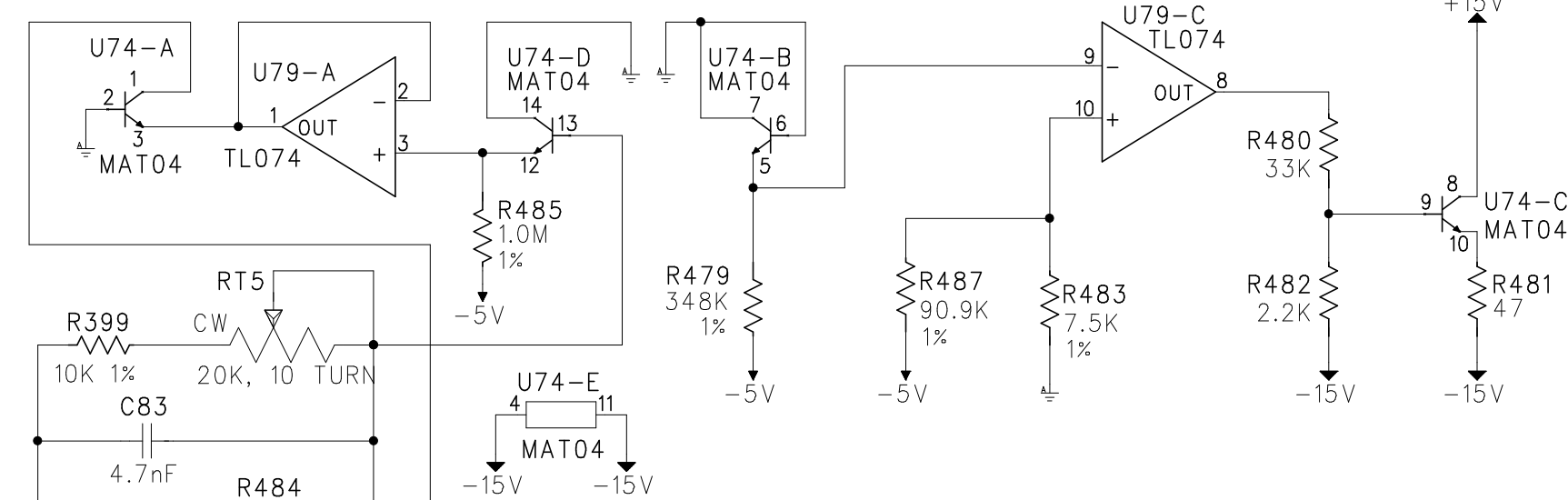

OSCILLATOR SECTION

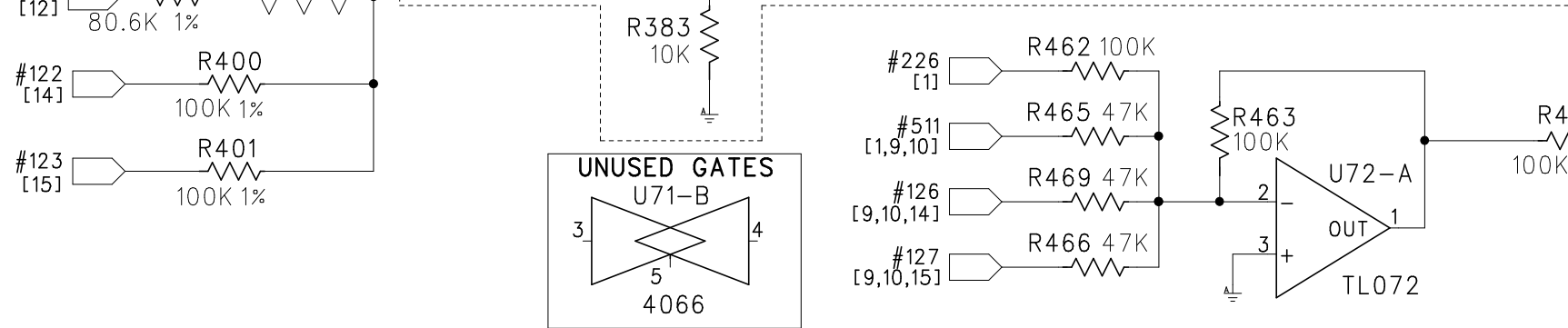
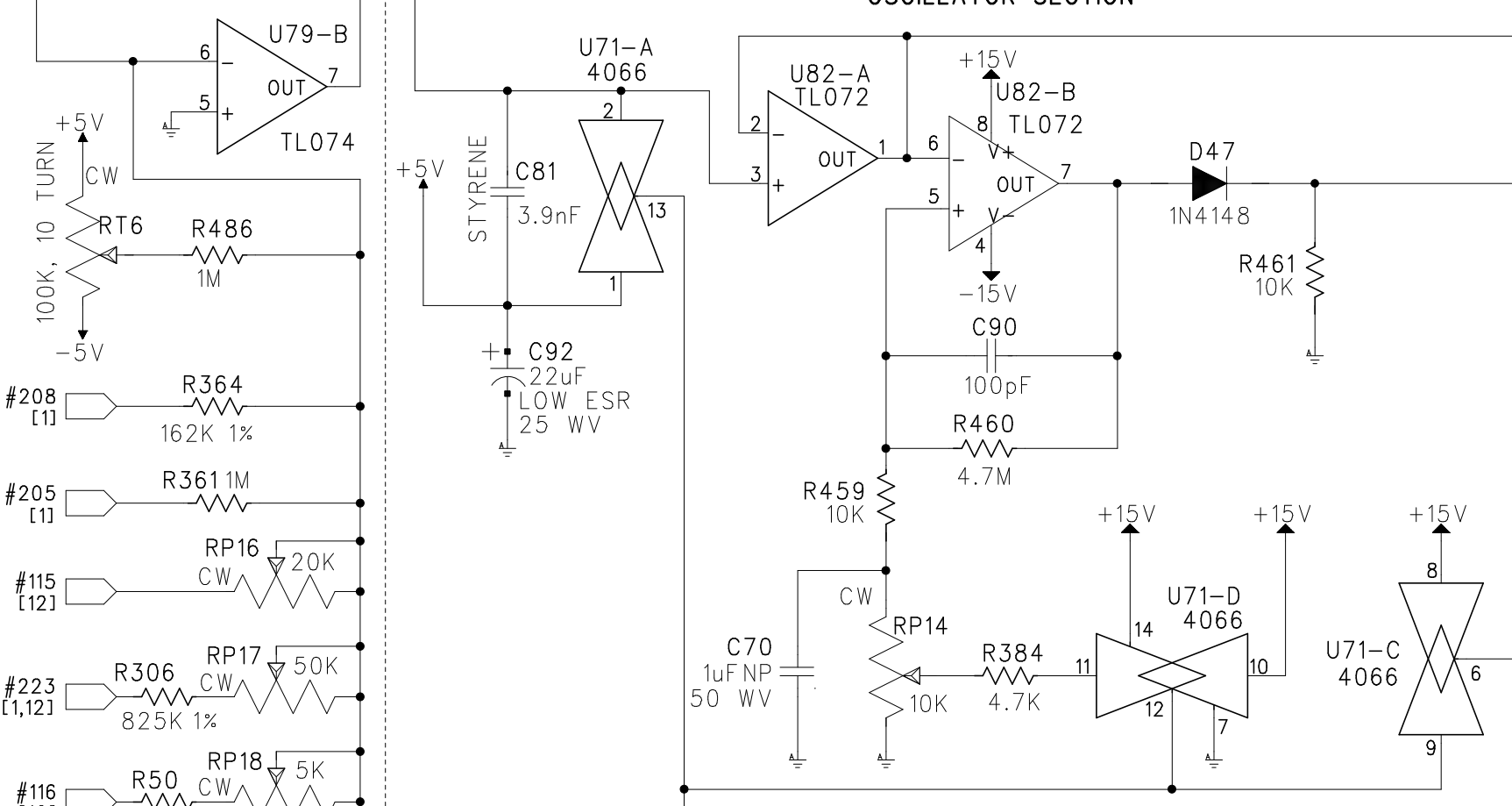

WAVESHAPING SECTION

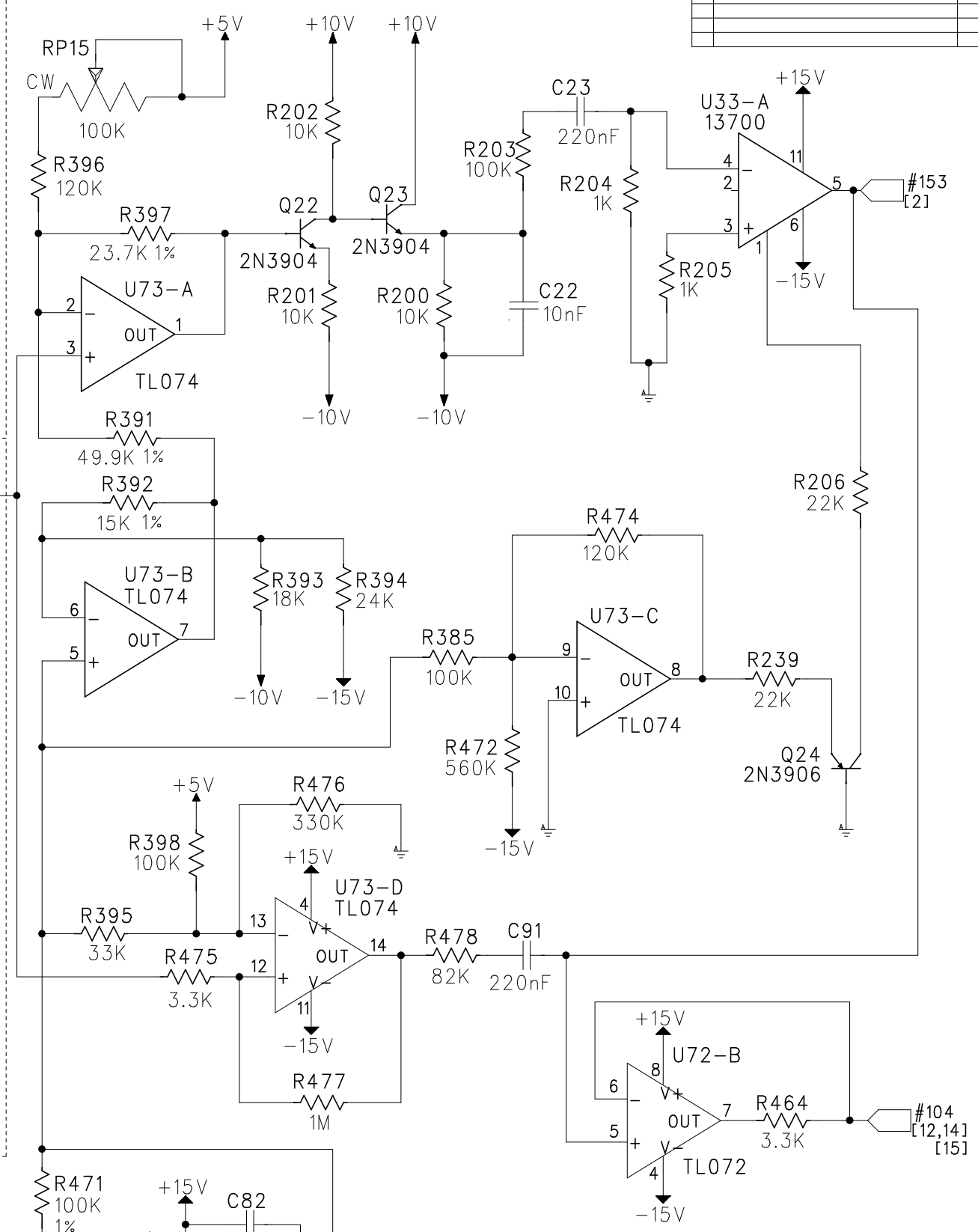

REVISION RECORD		
LTR	DESCRIPTION	BY

COMPANY: **Moog Music Inc.**

TITLE: **ANALOG BOARD; 11-404P**

DRAWN: J. Mathews	DATED: 7/24/2002	CODE:	SIZE:	DRAWING NO:	REV:
CHECKED: B. Moog	DATED: 7/25/2002	D		JN10759.SCH	
QUALITY CONTROL: S. Region	DATED: 7/25/2002				
RELEASED: J. Mathews	DATED: 7/26/2002	SCALE: NTS	SHEET: 11 OF 15		

OSCILLATOR DRIVERS

REVISION RECORD		
LTR	DESCRIPTION	BY

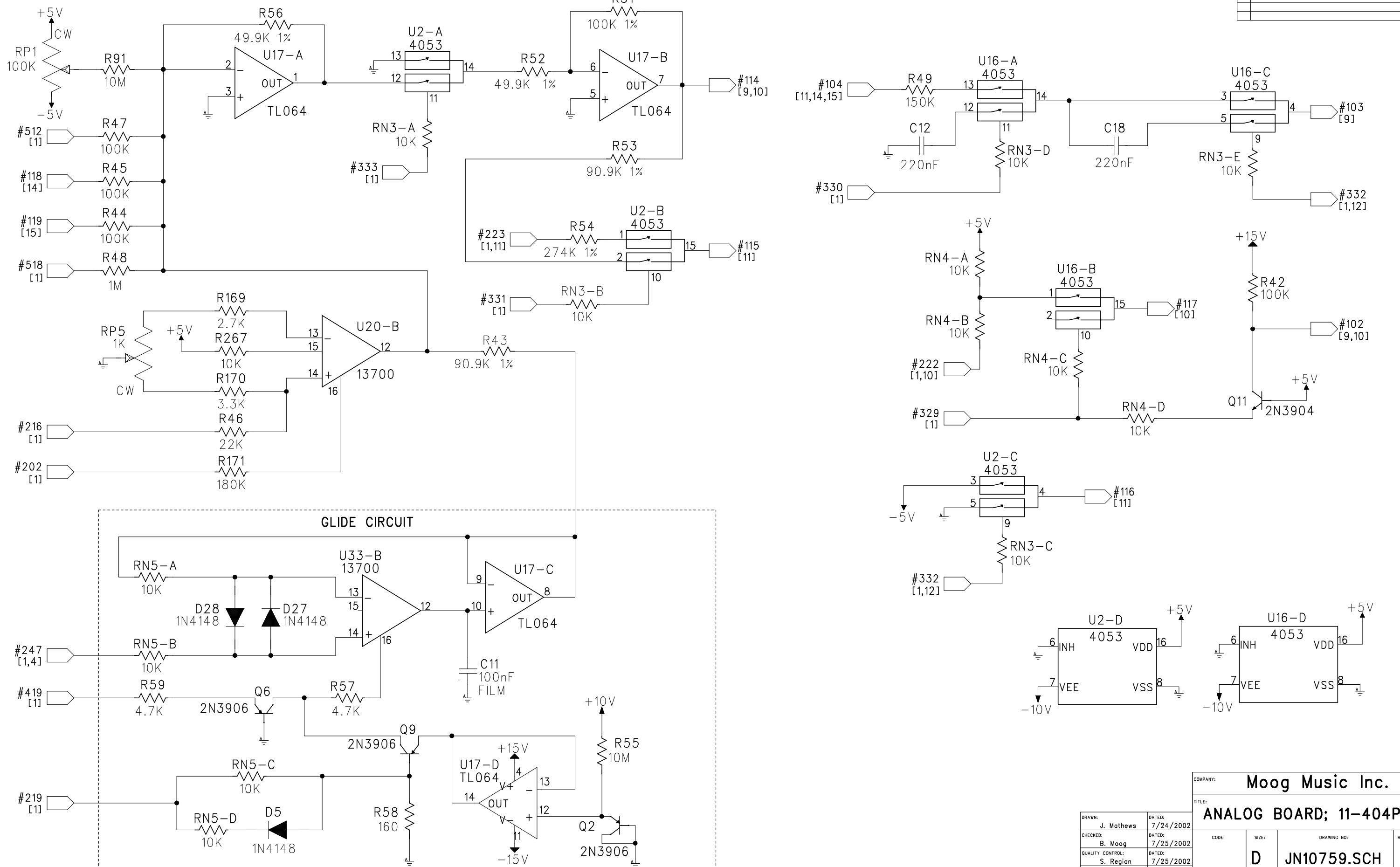

COMPANY:		Moog Music Inc.			
TITLE:		ANALOG BOARD; 11-404P			
DRAWN:	DATED:	CODE:	SIZE:	DRAWING NO:	REV:
J. Mathews	7/24/2002				
CHECKED:	DATED:	D		JN10759.SCH	
B. Moog	7/25/2002				
QUALITY CONTROL:	DATED:				
S. Region	7/25/2002				
RELEASED:	DATED:				
J. Mathews	7/26/2002	SCALE: NTS		SHEET: 12 OF 15	

REVISION RECORD	
DESCRIPTION	BY

LFO SECTION

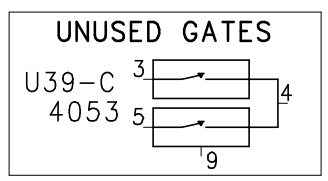
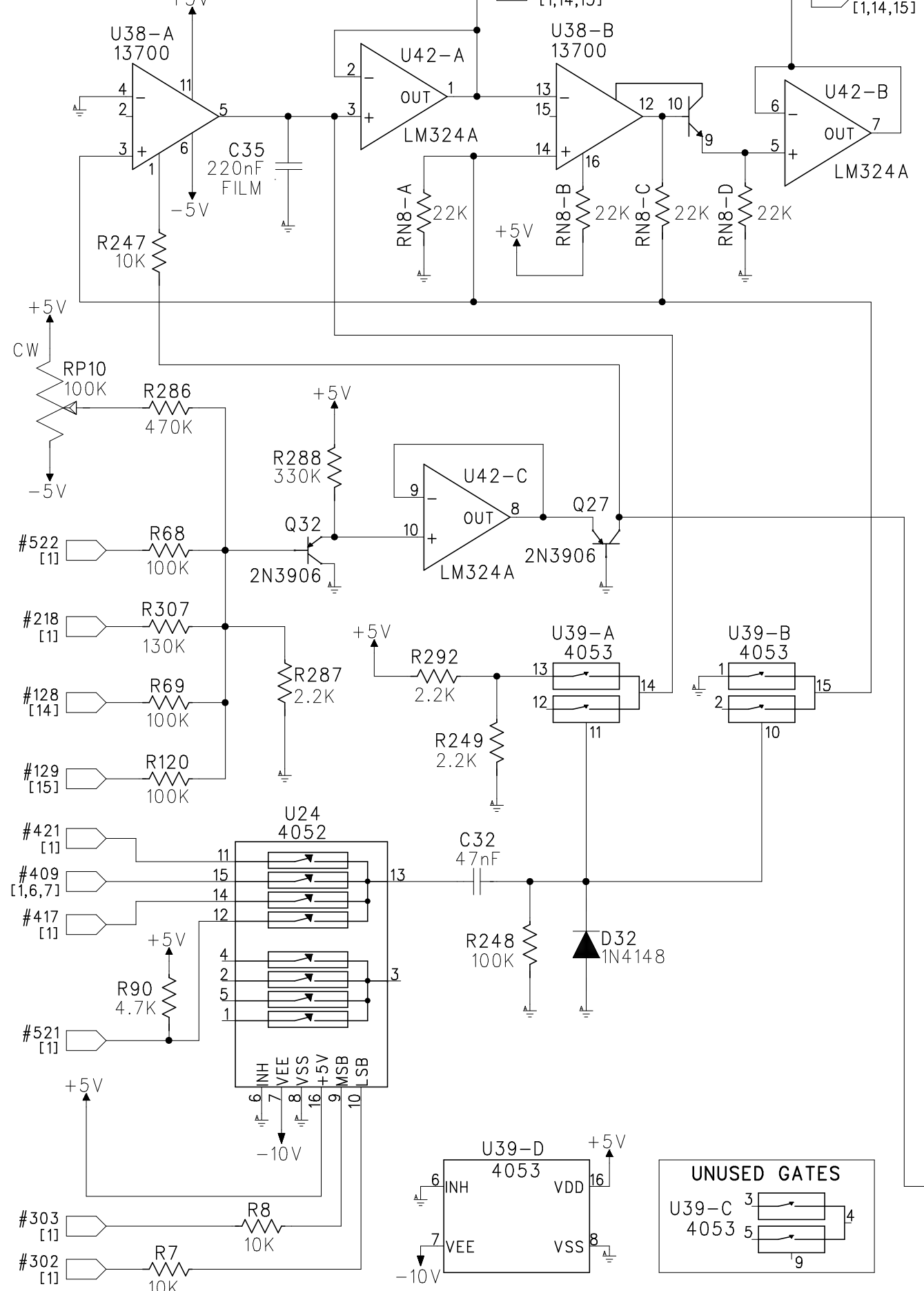

NOISE SECTION

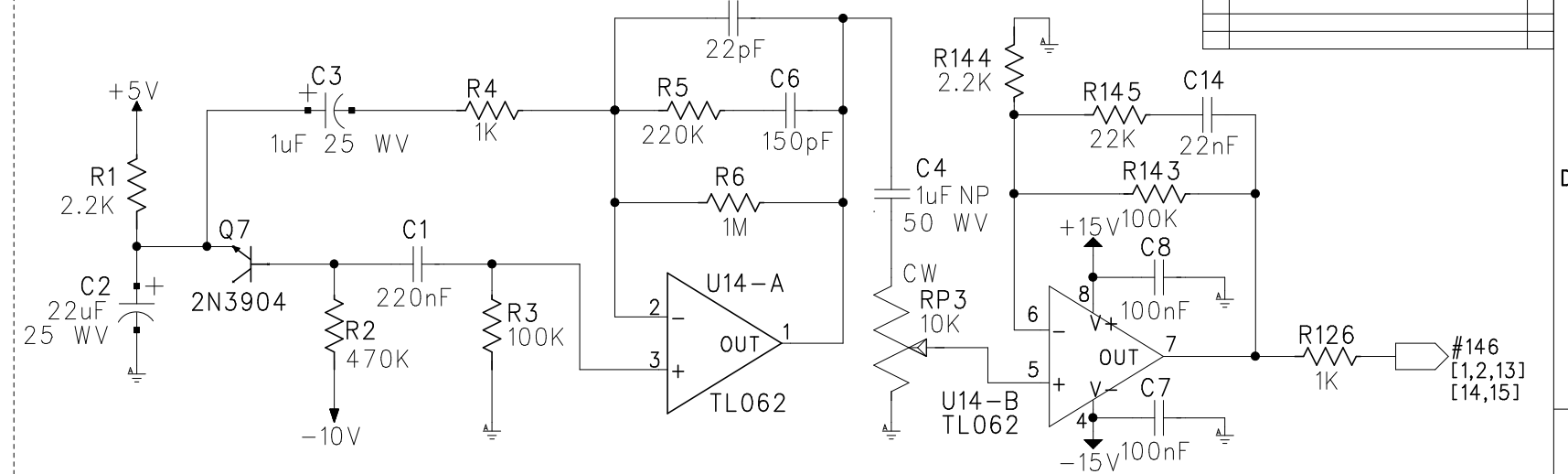

SAMPLE & HOLD SECTION

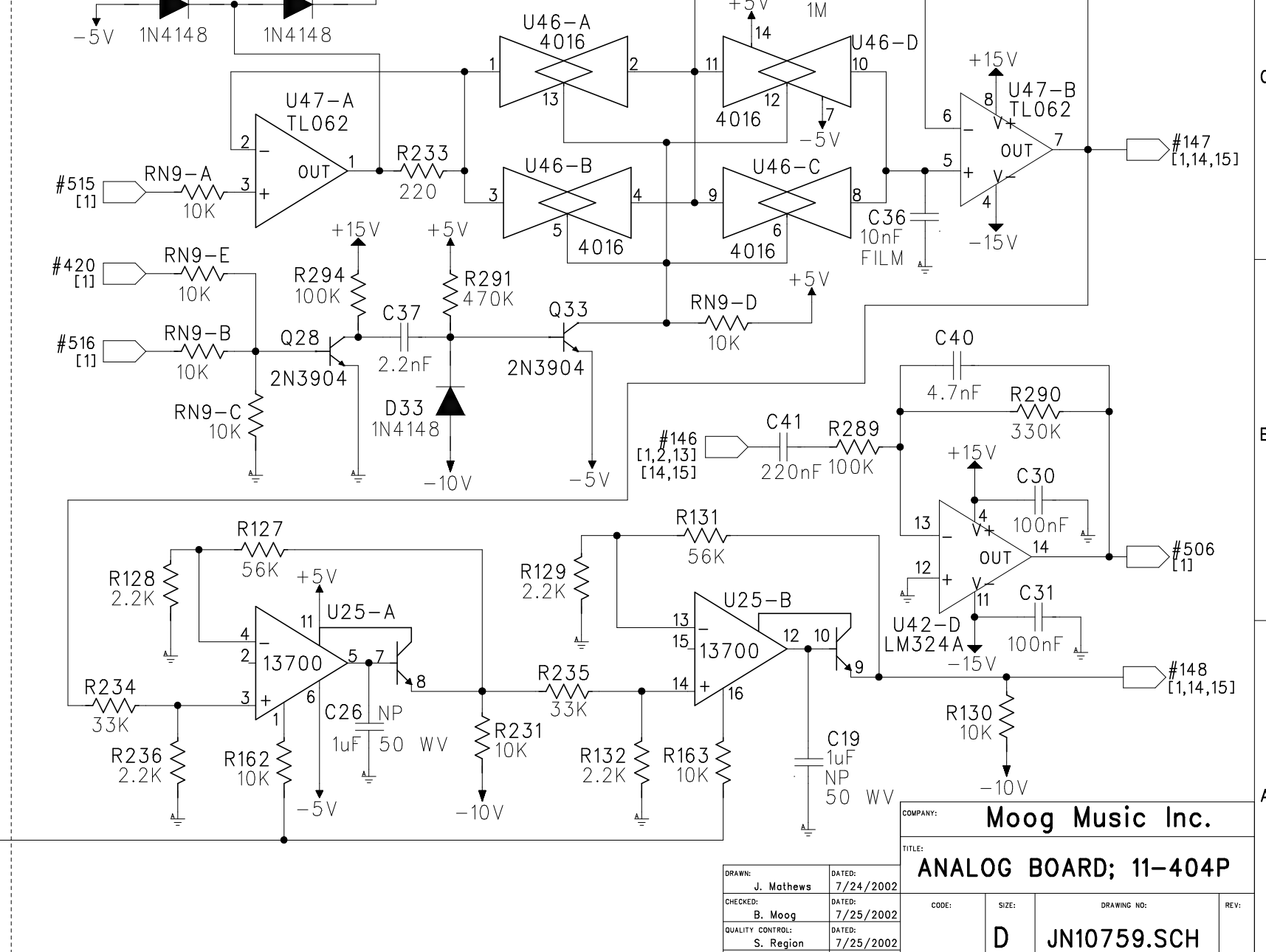

COMPANY: **Moog Music Inc.**

TITLE: **ANALOG BOARD; 11-404P**

DRAWN: J. Mathews	DATED: 7/24/2002	CODE:	SIZE:	DRAWING NO:	REV:
CHECKED: B. Moog	DATED: 7/25/2002	D JN10759.SCH			
QUALITY CONTROL: S. Region	DATED: 7/25/2002				
RELEASED: J. Mathews	DATED: 7/26/2002				

SCALE: NTS SHEET: 13 OF 15

WHEEL MOD BUSS

REVISION RECORD		
LTR	DESCRIPTION	BY

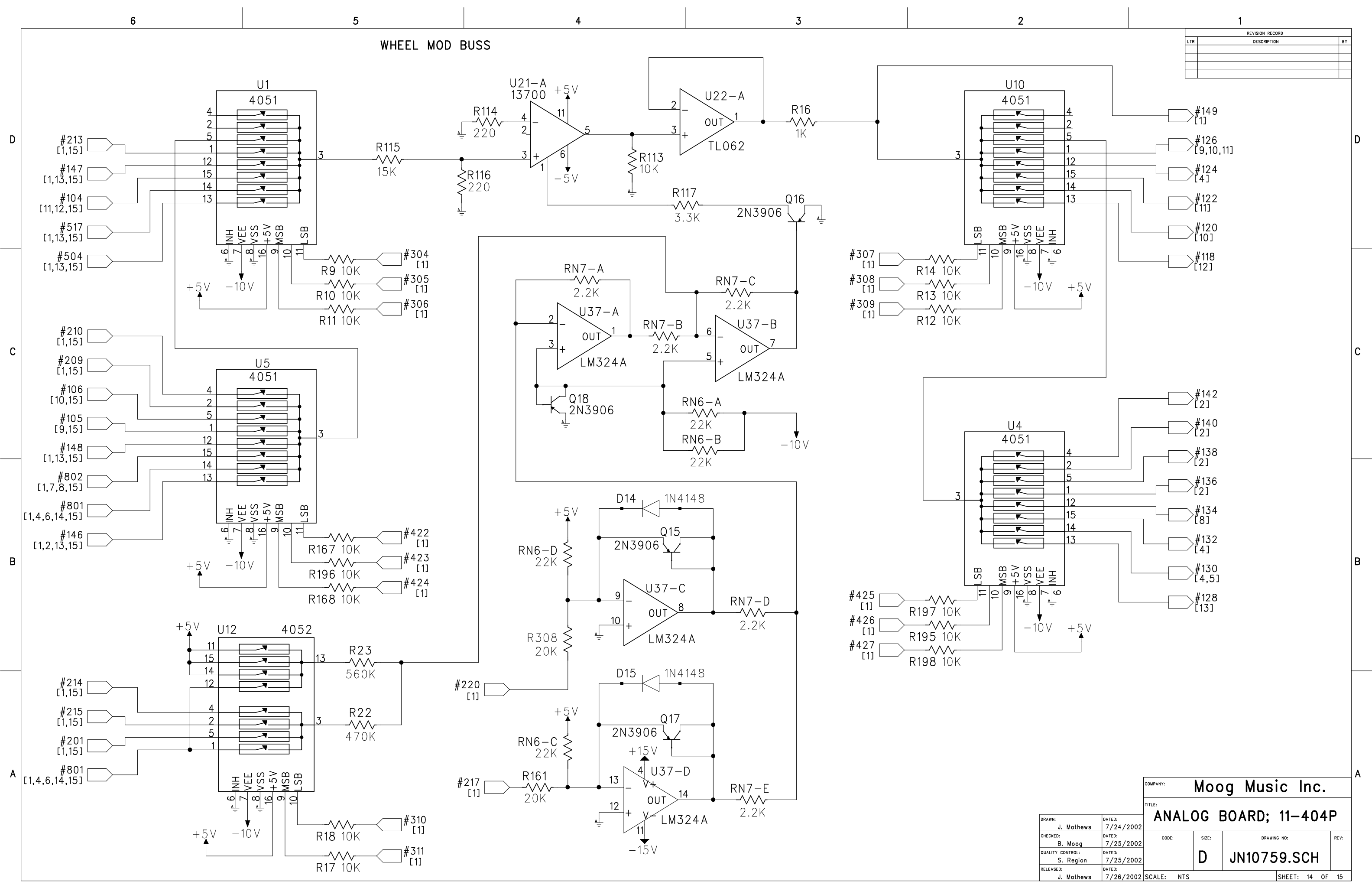

COMPANY: **Moog Music Inc.**

TITLE: **ANALOG BOARD; 11-404P**

DRAWN: J. Mathews	DATED: 7/24/2002	CODE:	SIZE:	DRAWING NO:	REV:
CHECKED: B. Moog	DATED: 7/25/2002	D		JN10759.SCH	
QUALITY CONTROL: S. Region	DATED: 7/25/2002				
RELEASED: J. Mathews	DATED: 7/26/2002	SCALE: NTS	SHEET: 14 OF 15		

PEDAL MOD BUSS

REVISION RECORD		
LTR	DESCRIPTION	BY

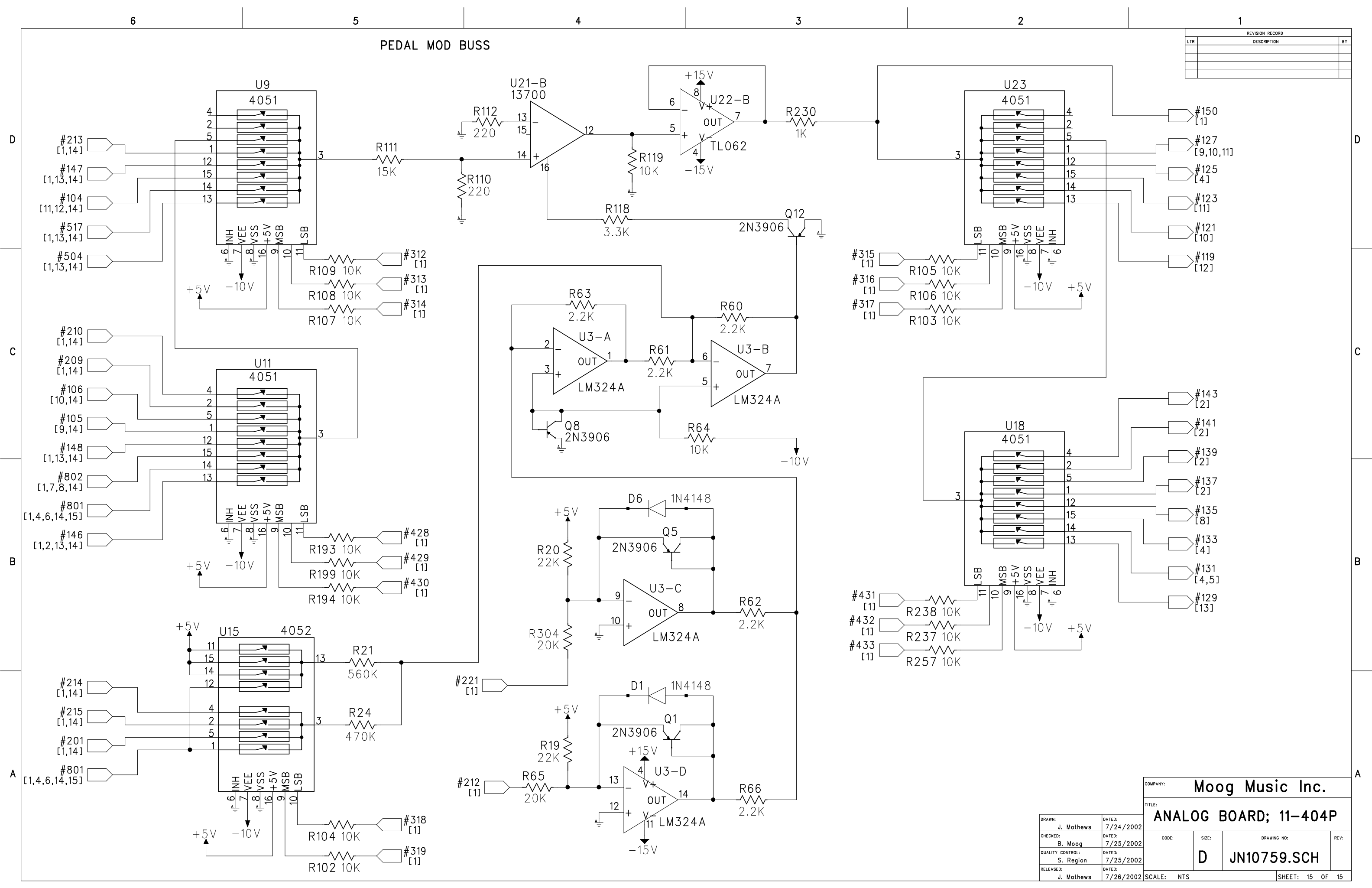

COMPANY: **Moog Music Inc.**

TITLE: **ANALOG BOARD; 11-404P**

DRAWN: J. Mathews	DATED: 7/24/2002	CODE:	SIZE:	DRAWING NO:	REV:
CHECKED: B. Moog	DATED: 7/25/2002	D		JN10759.SCH	
QUALITY CONTROL: S. Region	DATED: 7/25/2002				
RELEASED: J. Mathews	DATED: 7/26/2002	SCALE: NTS	SHEET: 15 OF 15		

6 5 4 3 2 1

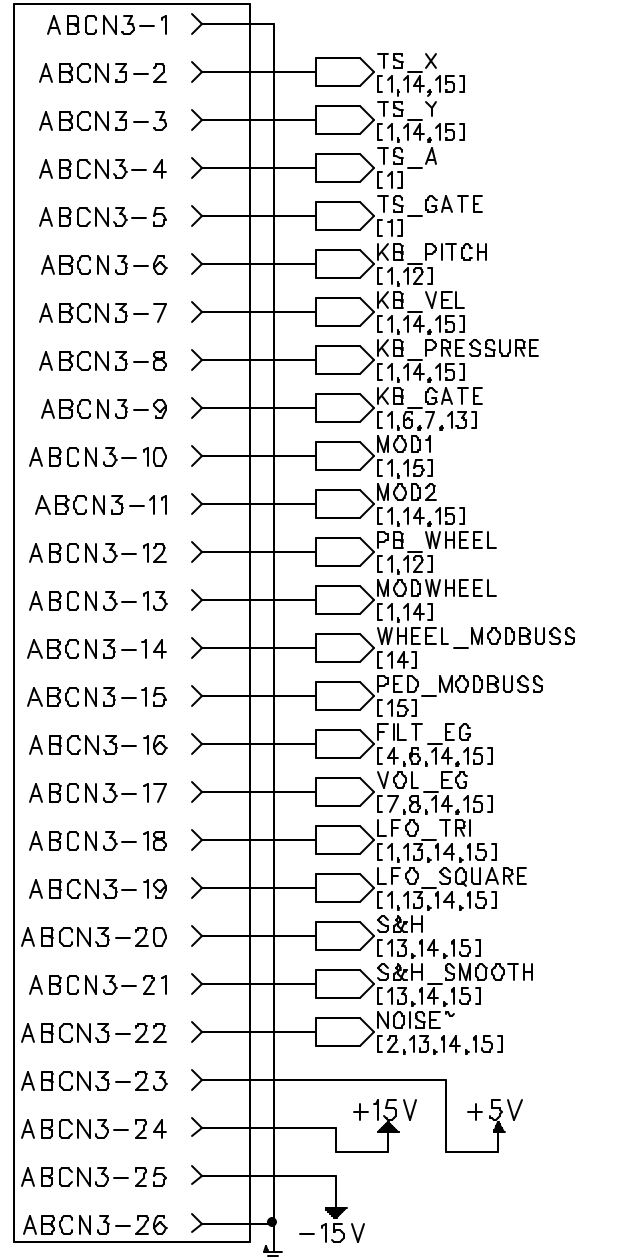
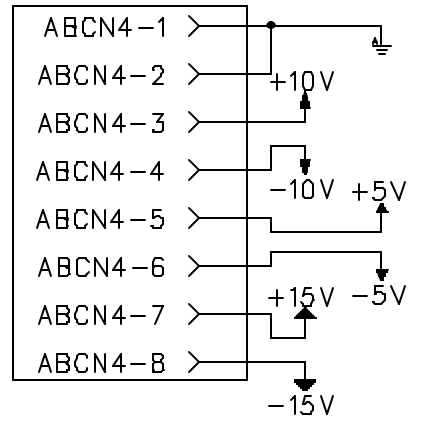
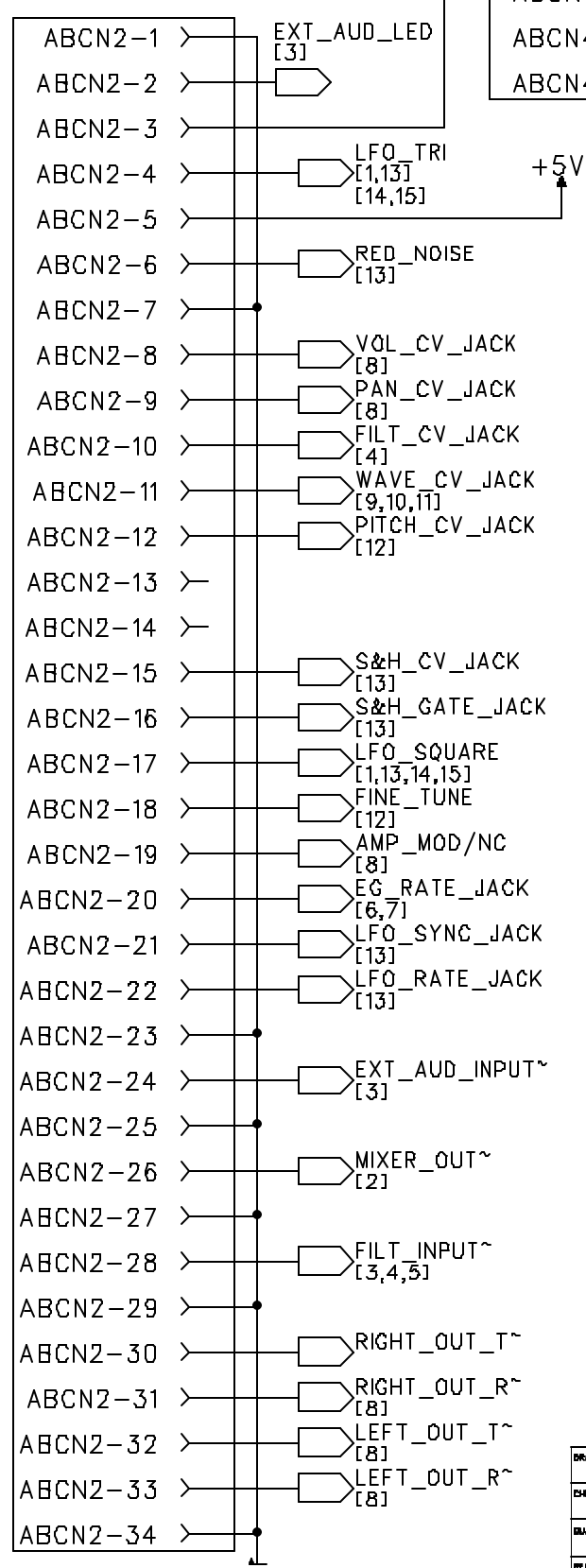
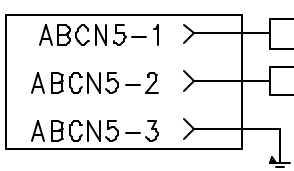
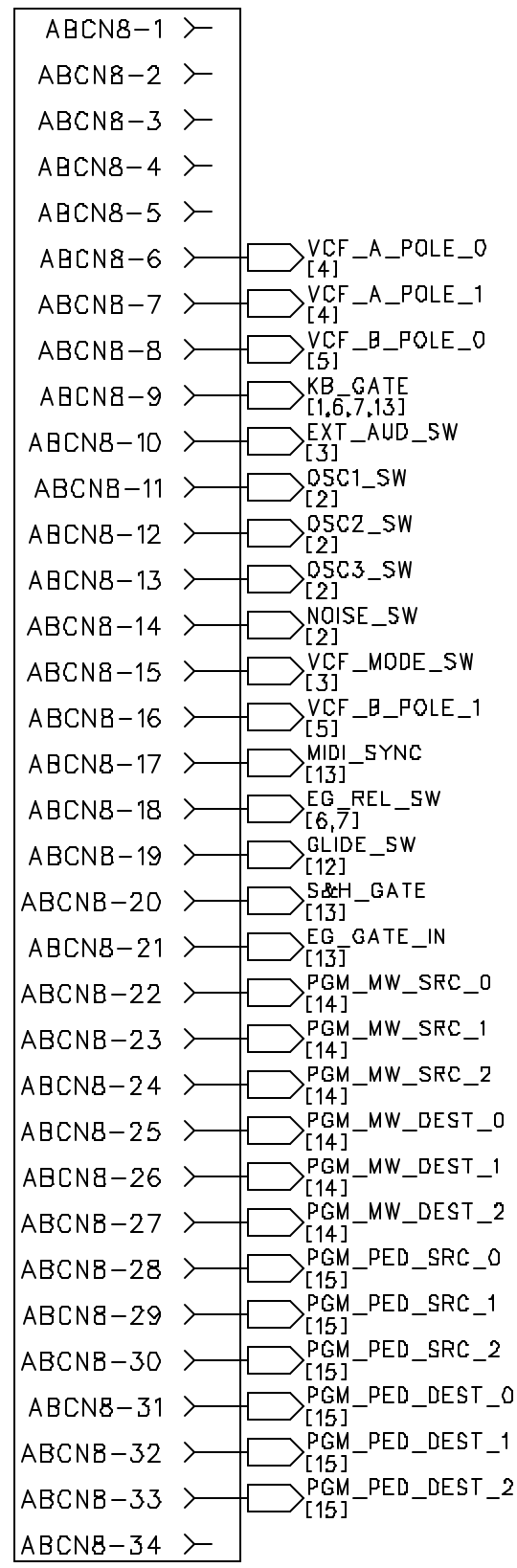
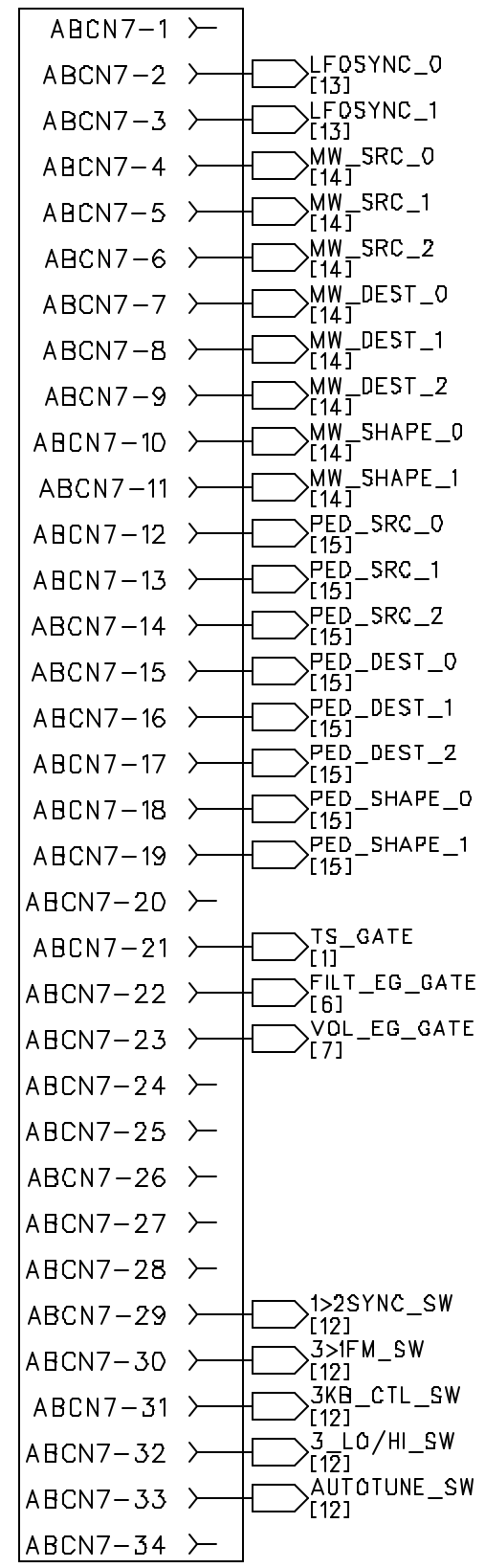
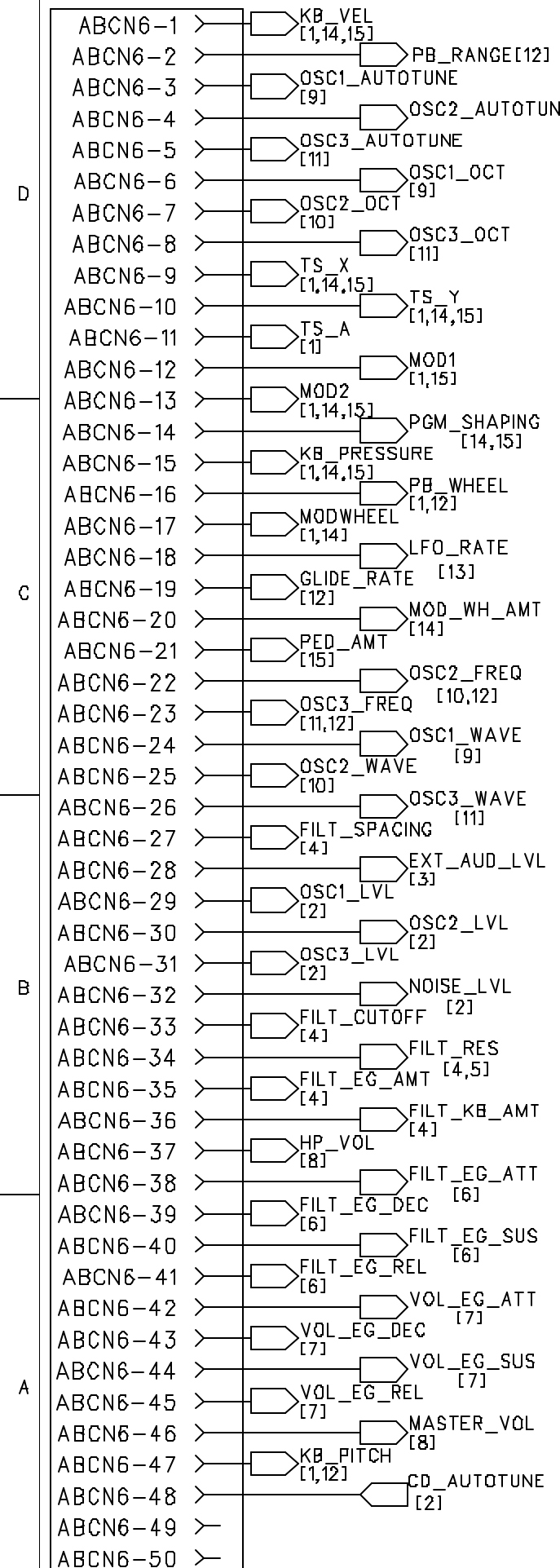

REVISION RECORD	
DATE	DESCRIPTION

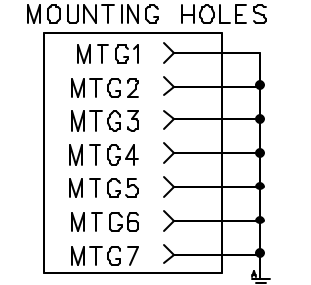

COMPANY: **Moog Music Inc.**

TITLE: **ANALOG BOARD; 11-404P**

DRAWN: J. Mathews	DATE: 7/24/2002	CODE:	SIZE:	ISSUE NO:	REV:
CHECKED: B. Moog	DATE: 7/25/2002	D	JN10759.SCH	1	DF 15
QUALITY CONTROL: S. Regan	DATE: 7/26/2002				
RELEASED: J. Mathews	DATE: 7/26/2002	SCALE: NTS	SHEET: 1 OF 15		

REVISION RECORD	
LT#	DESCRIPTION

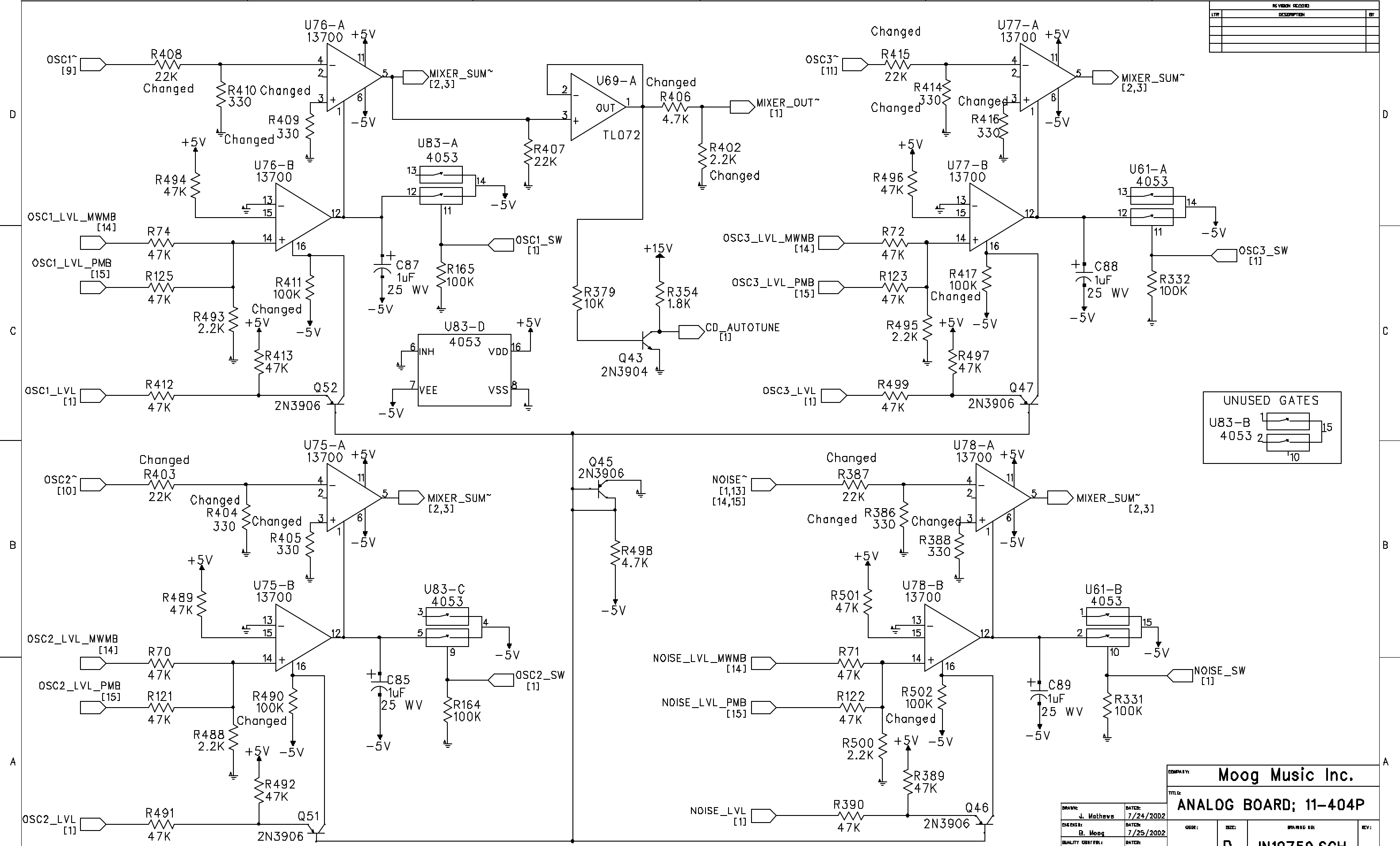

UNUSED GATES
 U83-B 4053

COMPANY: **Moog Music Inc.**

TITLE: **ANALOG BOARD; 11-404P**

DRAWN: J. Mathews	DATE: 7/24/2002	CODE:	SIZE:	ISSUE NO.:	REV.:
CHECKED: B. Moog	DATE: 7/25/2002	D			
QUALITY CONTROL: S. Regan	DATE: 7/25/2002				
RELEASED: J. Mathews	DATE: 7/26/2002				

SCALE: NTS SHEET: 2 OF 15

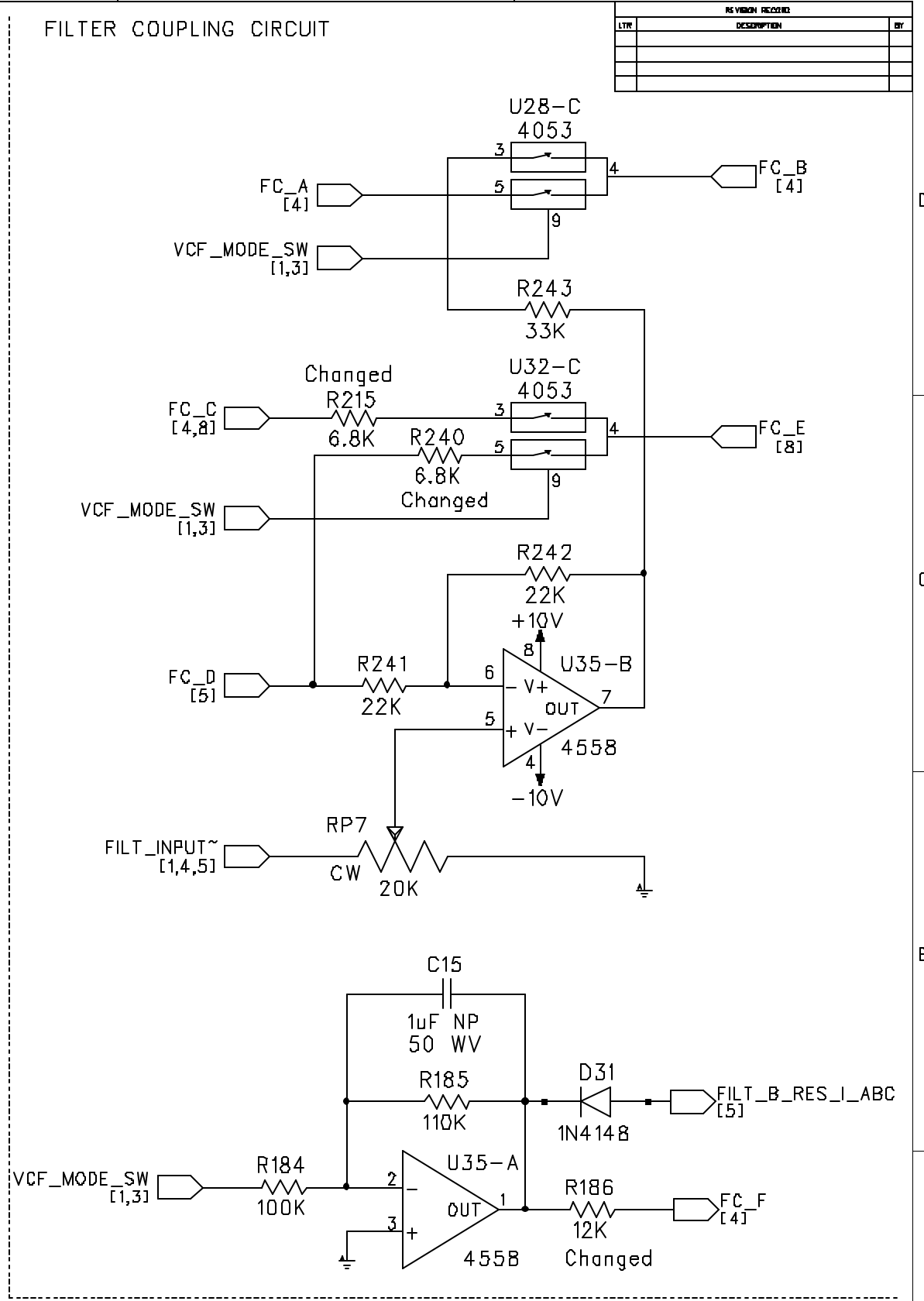
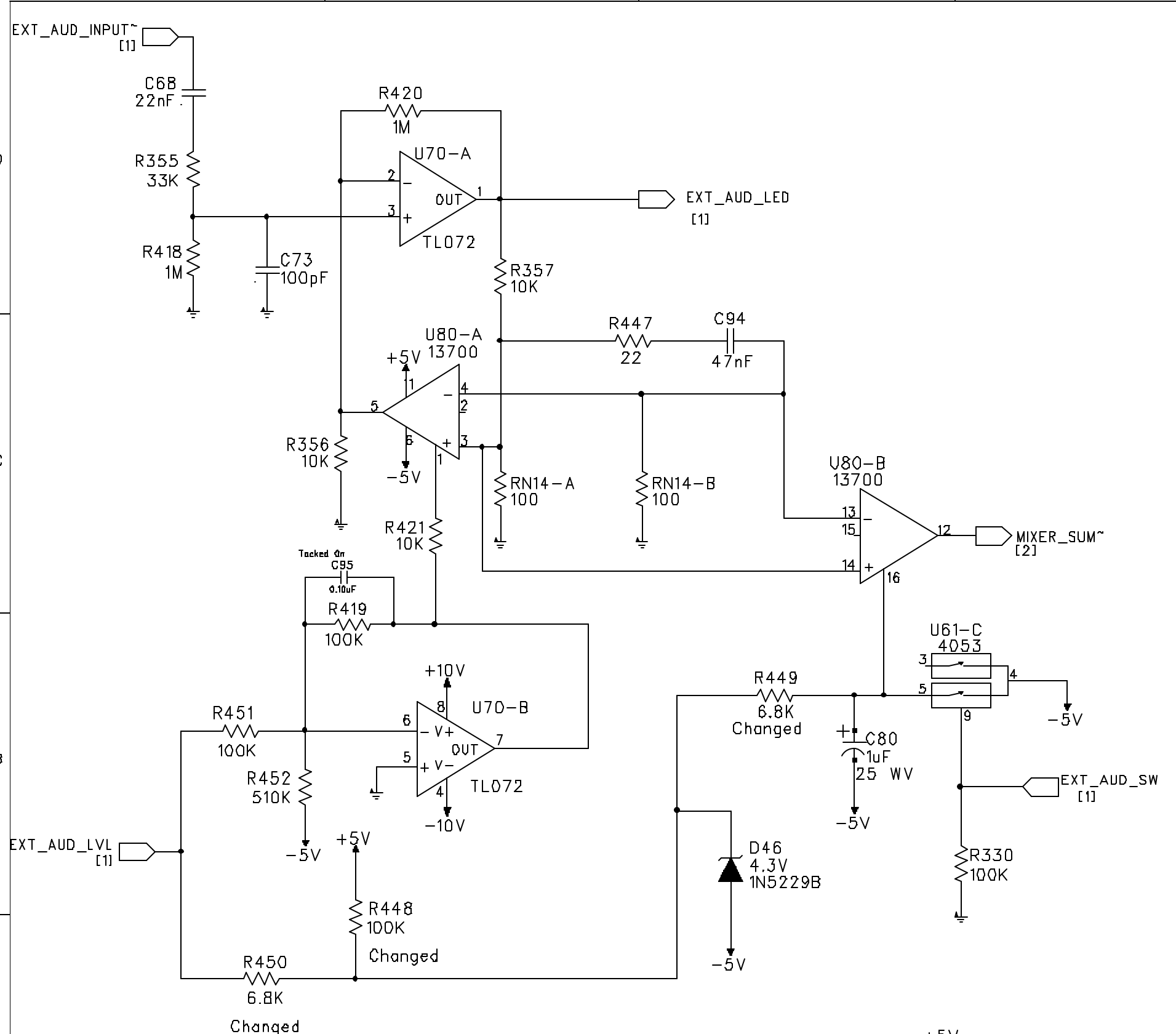

REVISION RECORD	
LT#	DESCRIPTION

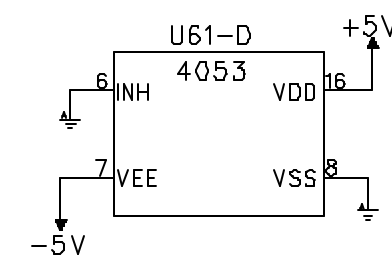

UNUSED GATES

RN14-C

100

COMPANY: Moog Music Inc.				
TITLE: ANALOG BOARD; 11-404P				
DRAWN: J. Mathews	DATE: 7/24/2002	QTY: D	REV: 1	SCALE: NTS
CHECKED: B. Moog	DATE: 7/25/2002	PARTS LIST: JN10759.SCH		
QUALITY CONTROL: S. Regan	DATE: 7/25/2002	SHEET: 3 OF 15		
RELEASED: J. Mathews	DATE: 7/26/2002			

6 5 4 3 2 1

REVISION RECORD	
LT#	DESCRIPTION

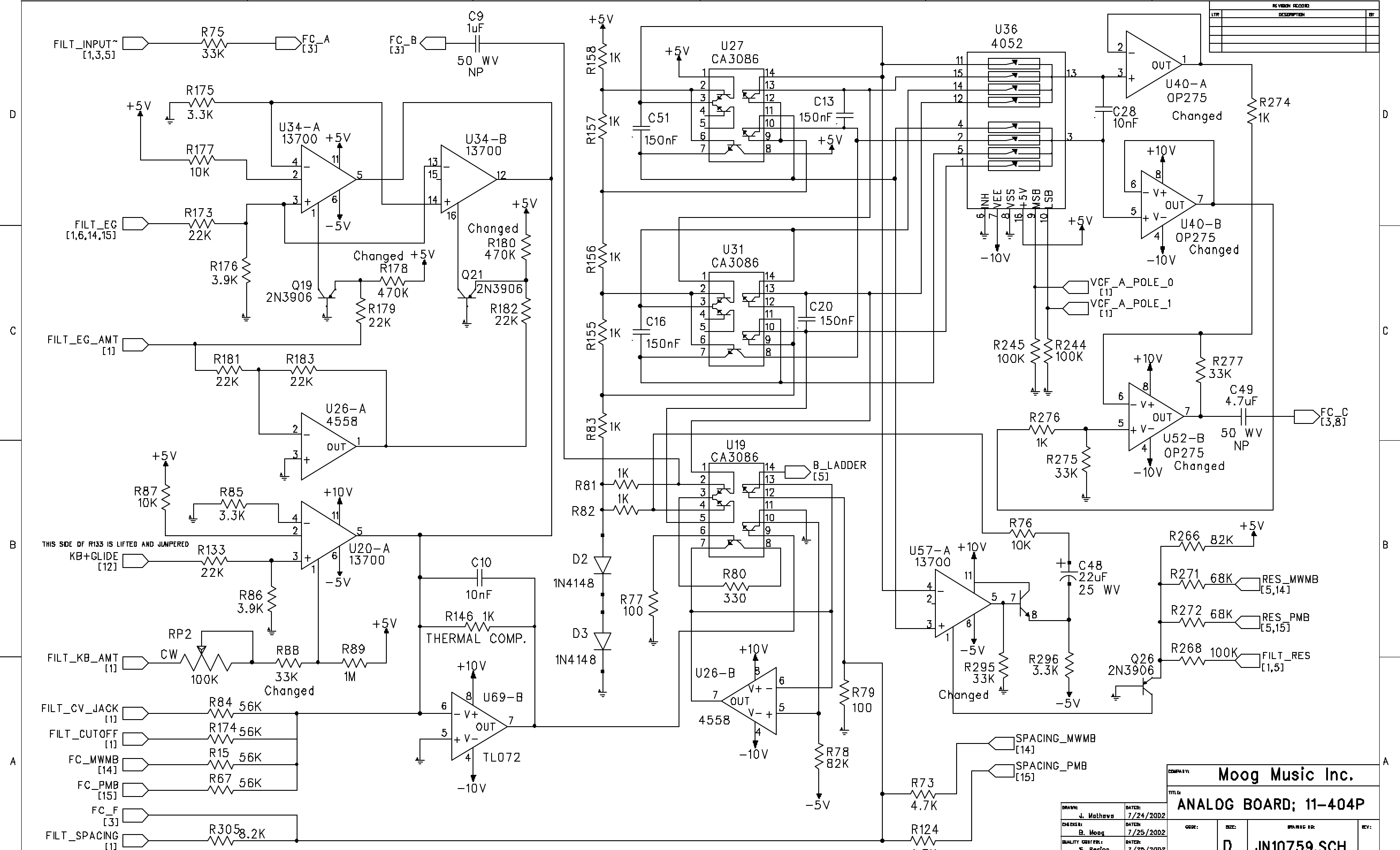

COMPANY: **Moog Music Inc.**

TITLE: **ANALOG BOARD; 11-404P**

DRAWN: J. Mathews	DATE: 7/24/2002				
CHECKED: B. Moog	DATE: 7/25/2002				
QUALITY CONTROL: S. Regan	DATE: 7/25/2002				
RELEASED: J. Mathews	DATE: 7/26/2002				

SCALE: NTS

SHEET: 4 OF 15

D

C

B

A

D

C

B

A

REVISION RECORD		
LT#	DESCRIPTION	BY

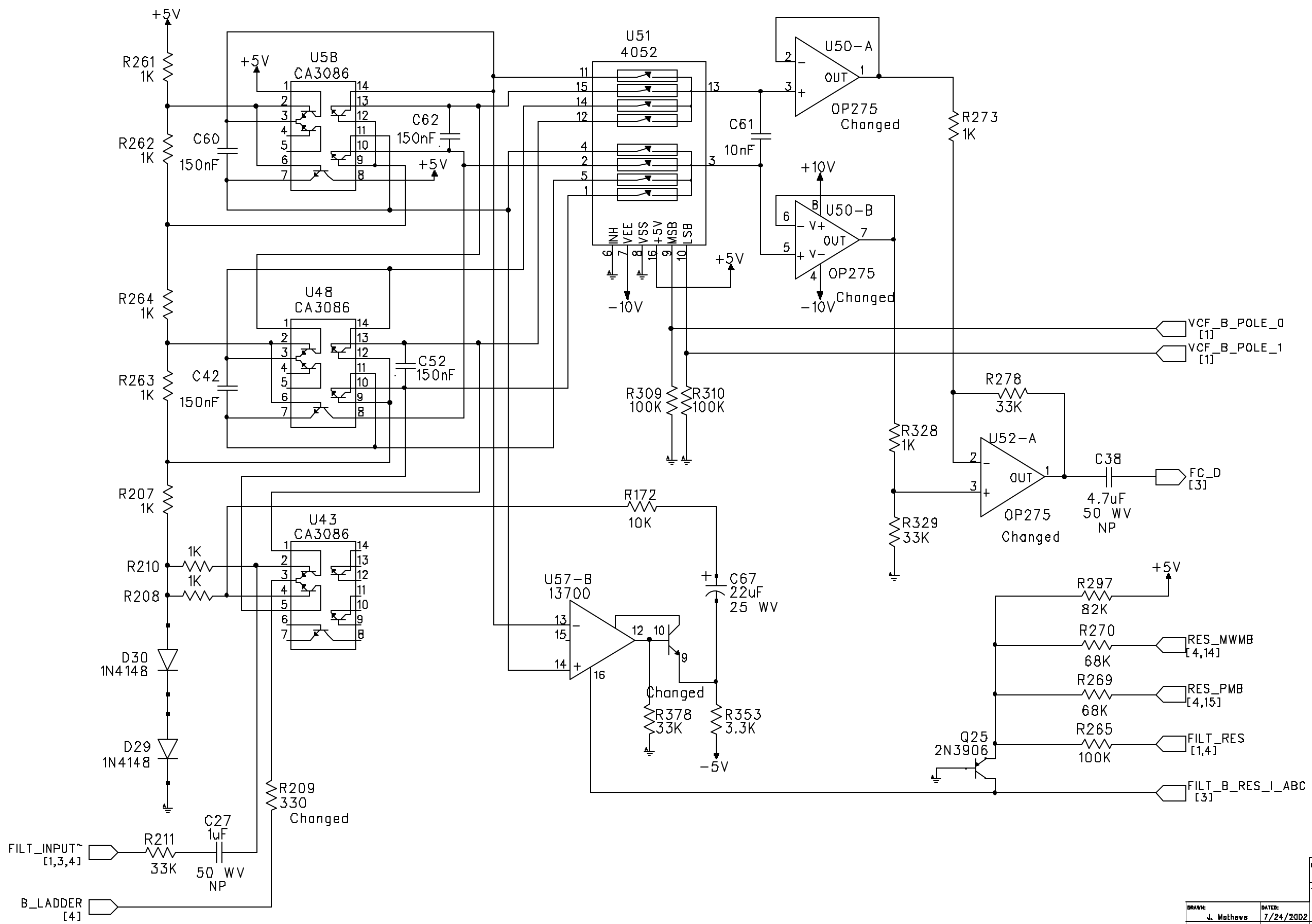

COMPANY: **Moog Music Inc.**

TITLE: **ANALOG BOARD; 11-404P**

DRAWN: J. Mathews	DATE: 7/24/2002	CODE:	SIZE:	ISSUE NO:	REV:
CHECKED: B. Moog	DATE: 7/25/2002				
QUALITY CONTROL: S. Regan	DATE: 7/25/2002				
RELEASED: J. Mathews	DATE: 7/26/2002				

SCALE: NTS

SHEET: 5 OF 15

REVISION RECORD		
LT#	DESCRIPTION	BY

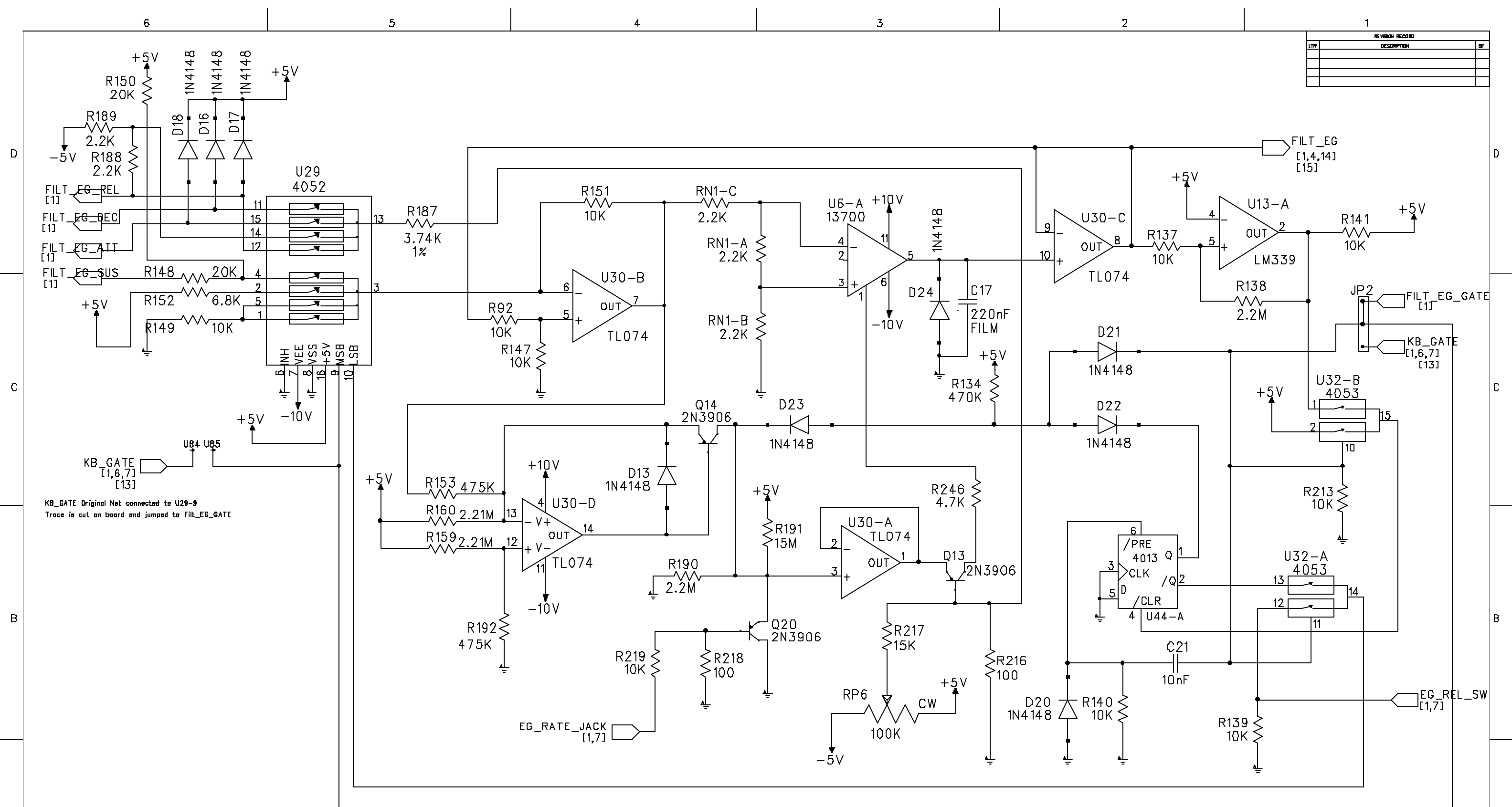

KB_GATE Original Net connected to U29-9
Trace is cut on board and jumped to FILT_EG_GATE

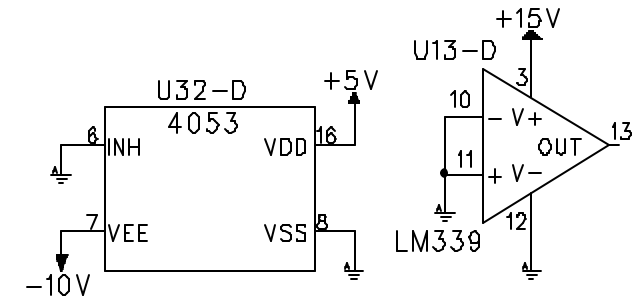
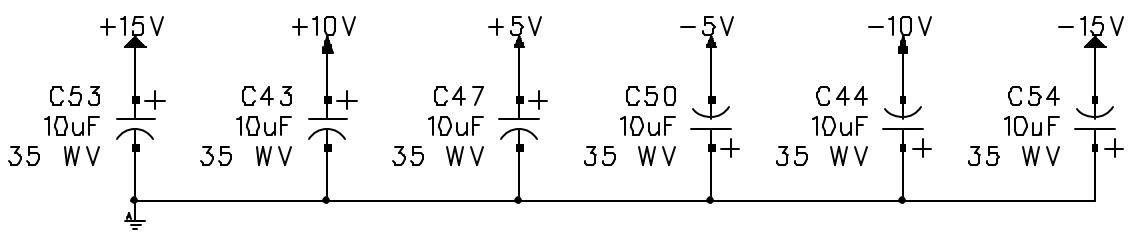
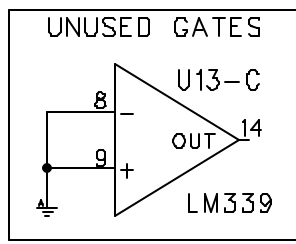

DRAWN: J. Mathews		DATE: 7/24/2002		COMPANY: Moog Music Inc.	
CHECKED: B. Moog		DATE: 7/25/2002		TITLE: ANALOG BOARD; 11-404P	
QUALITY CONTROL: S. Regan		DATE: 7/25/2002		CODE: D	ISSUE NO: JN10759.SCH
RELEASED: J. Mathews		DATE: 7/26/2002		SCALE: NTS	SHEET: 6 OF 15

REVISION RECORD		
LT#	DESCRIPTION	BY

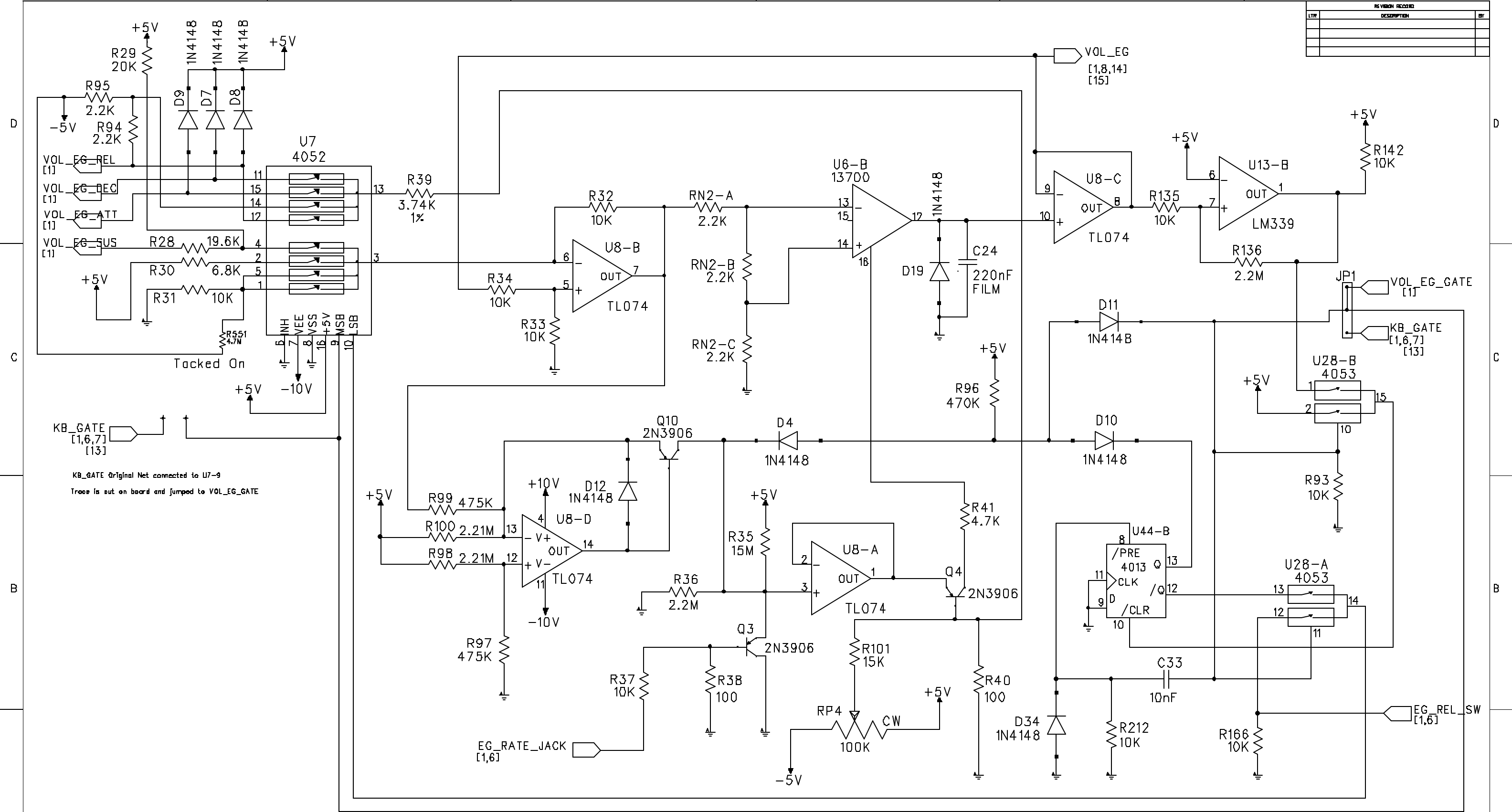

KB_GATE [1,6,7] [13]
 KB_GATE Original Net connected to U7-9
 Trace is out on board and jumped to VOL_EG_GATE

COMPANY: **Moog Music Inc.**

TITLE: **ANALOG BOARD; 11-404P**

DRAWN: J. Mathews	DATE: 7/24/2002	QTY:	SIZE:	ISSUE NO:	REV:
CHECKED: B. Moog	DATE: 7/25/2002	D JN10759.SCH			
QUALITY CONTROL: S. Regan	DATE: 7/26/2002				
RELEASED: J. Mathews	DATE: 7/26/2002	SCALE: NTS	SHEET: 7 OF 15		

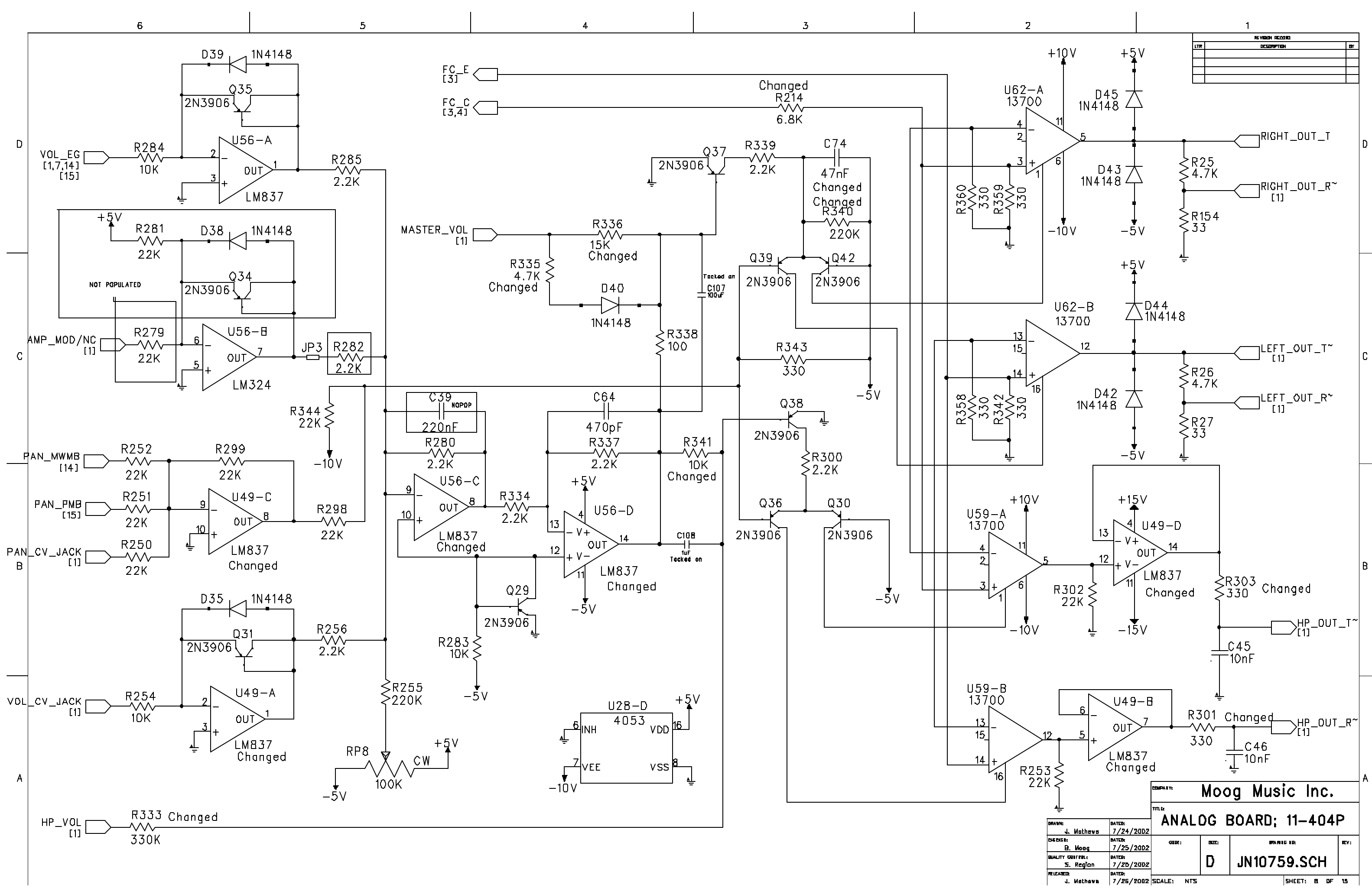

REVISION RECORD		
LT#	DESCRIPTION	BY

COMPANY: Moog Music Inc.					
TITLE: ANALOG BOARD; 11-404P					
DRAWN: J. Mathews	DATE: 7/24/2002	QTY:	REV:	ISSUE NO:	REV:
CHECKED: B. Moog	DATE: 7/25/2002	D		JN10759.SCH	
QUALITY CONTROL: S. Regan	DATE: 7/25/2002				
RELEASED: J. Mathews	DATE: 7/26/2002	SCALE: NTS			SHEET: 8 OF 15

6

5

4

3

2

1

ADDER/EXPONENTIATOR SECTION

WAVESHAPING SECTION

REVISION ENGINEER		
LTR	DESCRIPTION	BY

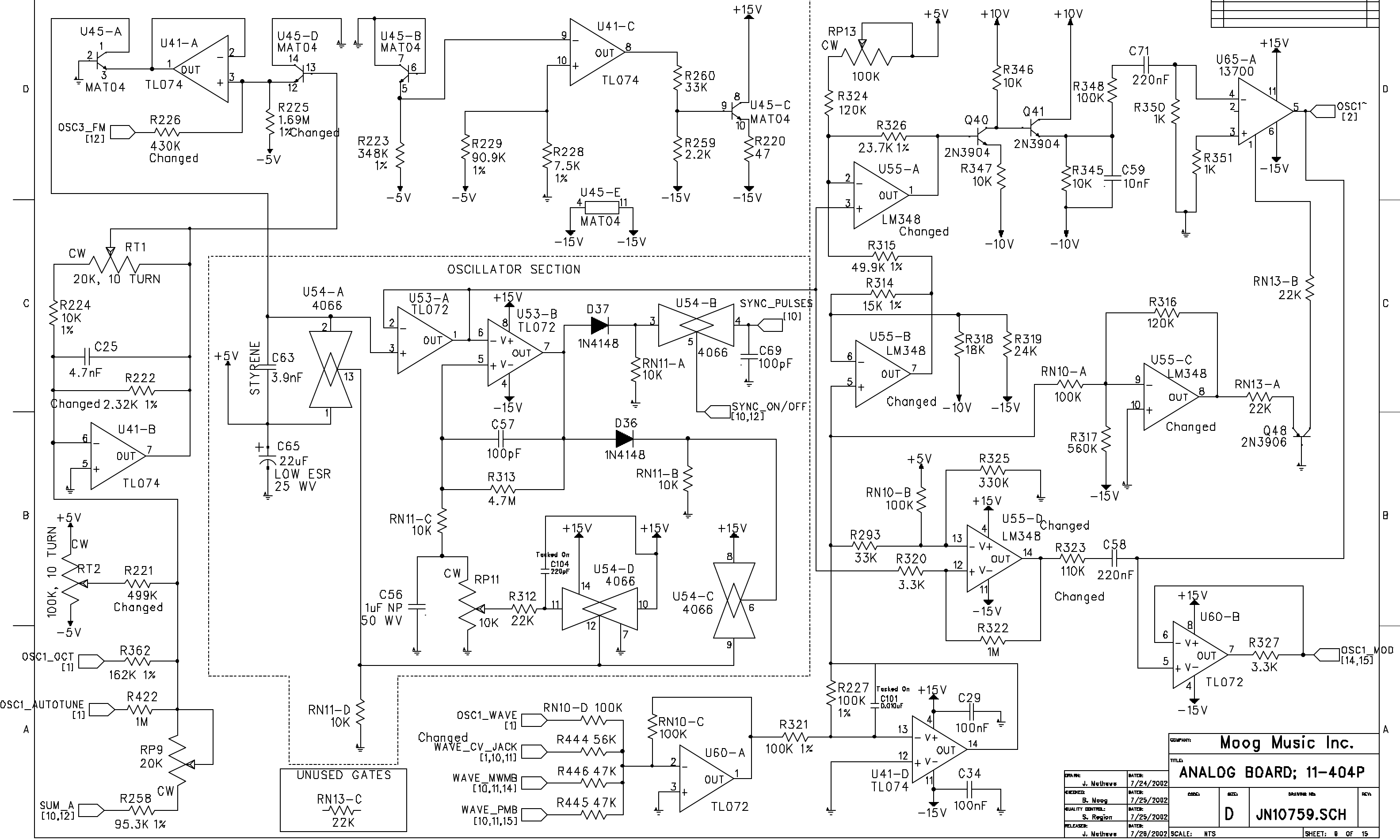

UNUSED GATES
RN13-C 22K

OSC1_WAVE [1] RN10-D 100K
 Changed WAVE_CV_JACK [1,10,11] R444 56K
 WAVE_MWMB [10,11,14] R446 47K
 WAVE_PMB [10,11,15] R445 47K

COMPANY: **Moog Music Inc.**

TITLE: **ANALOG BOARD; 11-404P**

DRAWN: J. Nethers	DATE: 7/24/2002	SCALE: NTS	SHEET: 8 OF 15
REVISION: B. Moog	DATE: 7/25/2002		
QUALITY CONTROL: S. Region	DATE: 7/25/2002		
RELEASED: J. Nethers	DATE: 7/26/2002		

DRAWING NO: **JN10759.SCH**

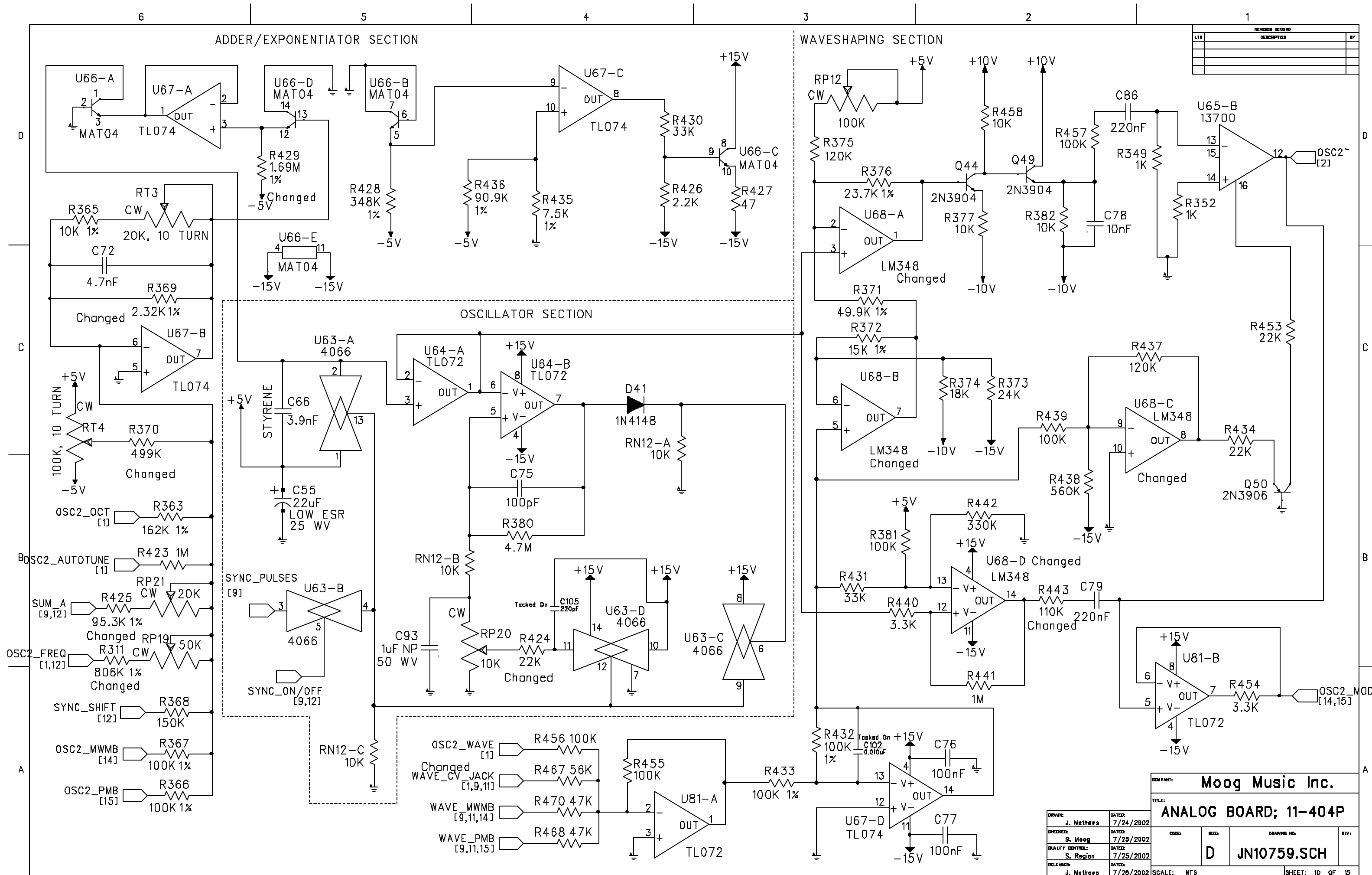

ADDER/EXPONENTIATOR SECTION

WAVESHAPING SECTION

OSCILLATOR SECTION

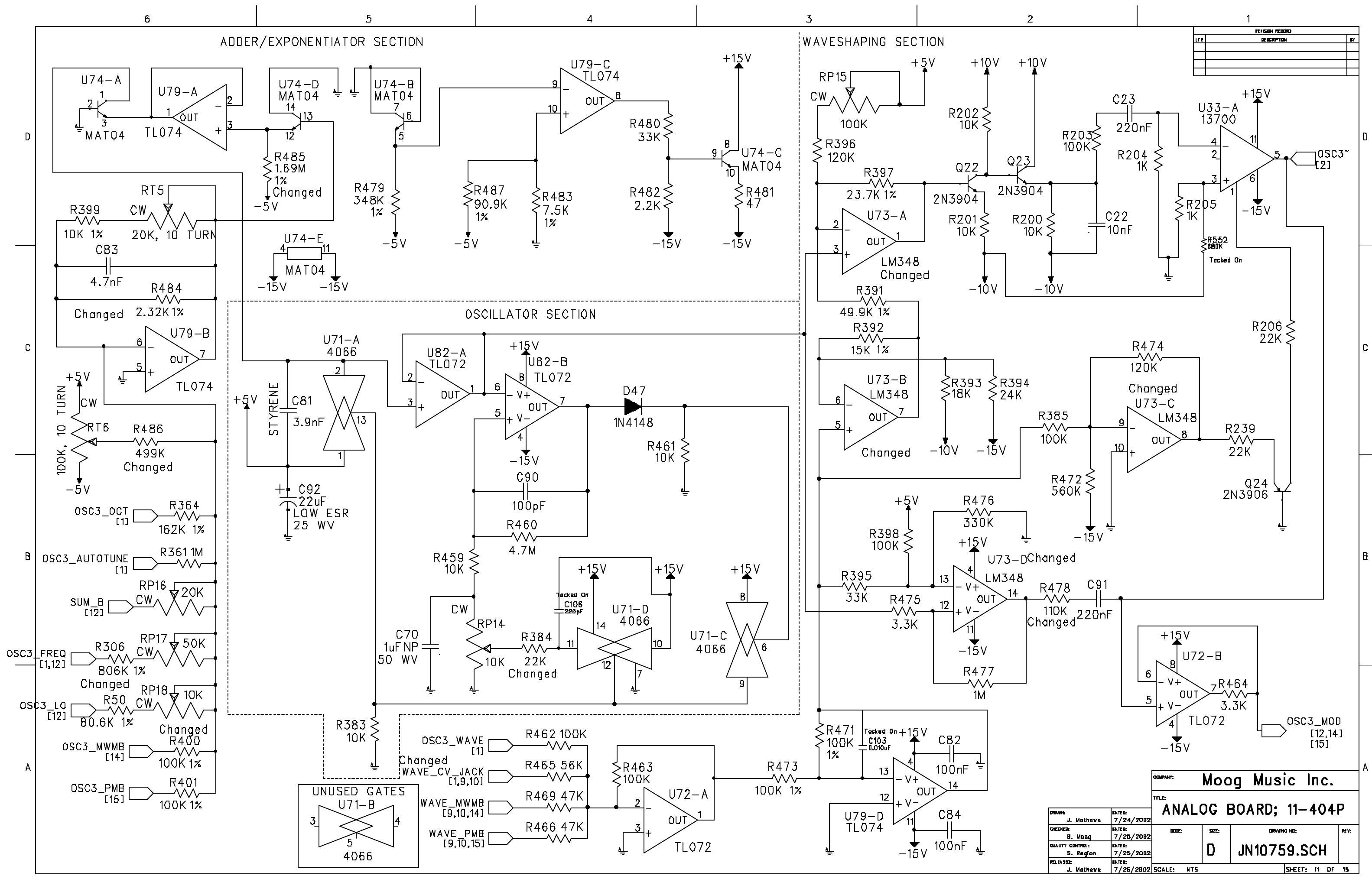

REVISION RECORD		
DATE	DESCRIPTION	BY

COMPANY: **Moog Music Inc.**

TITLE: **ANALOG BOARD; 11-404P**

DRAWN: J. Mathews	DATE: 7/24/2002	CODE: D	SIZE: 11	DRAWING NO: JN10759.SCH	REV: 15
CHECKED: B. Moog	DATE: 7/25/2002				
QUALITY CONTROL: S. Rajan	DATE: 7/25/2002				
RELEASED: J. Mathews	DATE: 7/25/2002				

SCALE: NTS SHEET: 11 OF 15

OSCILLATOR DRIVERS

REVISION HISTORY		
DATE	DESCRIPTION	BY

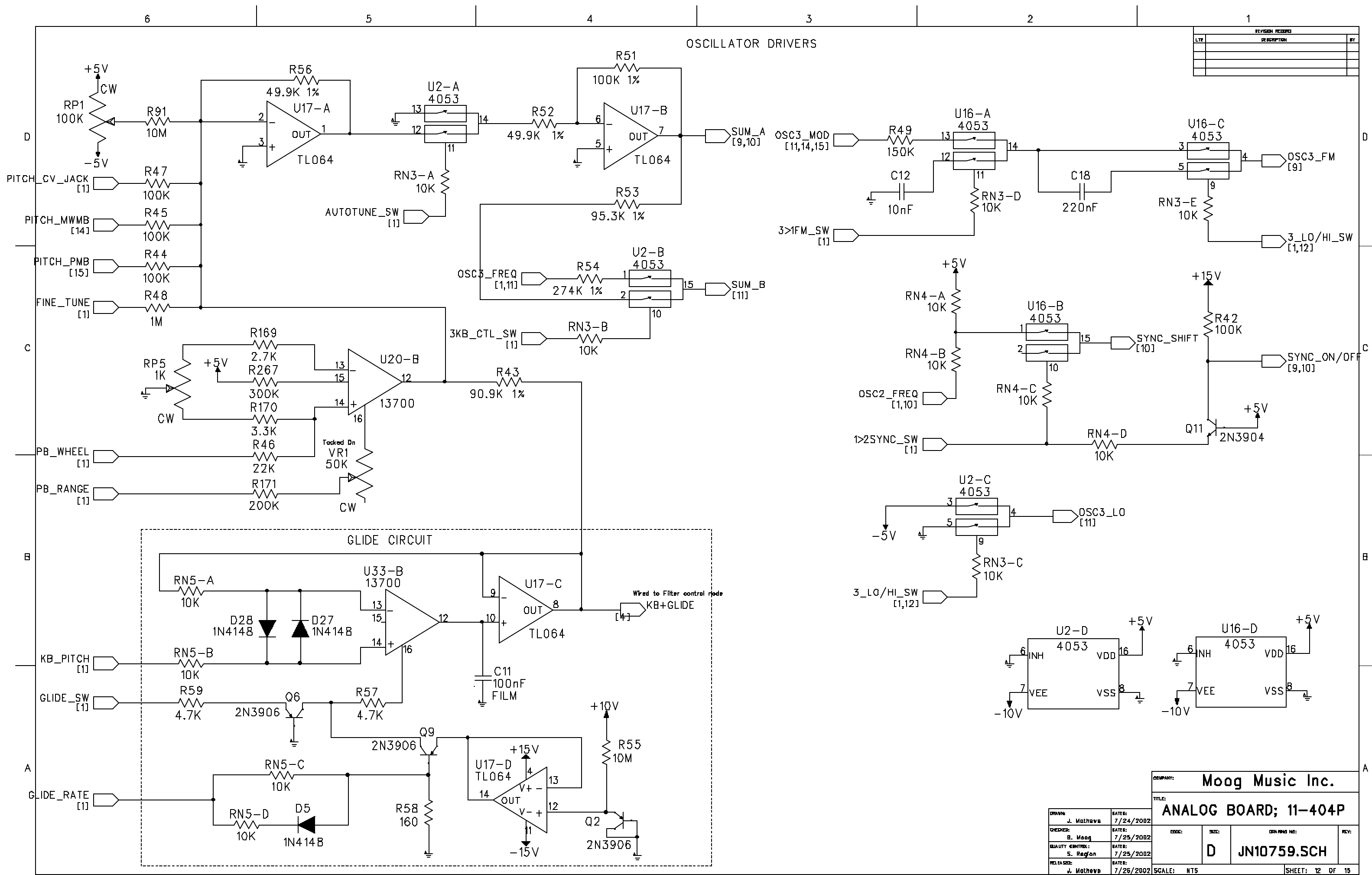

Moog Music Inc.

TITLE: ANALOG BOARD; 11-404P

DRAWN: J. Mathews	DATE: 7/24/2002	CODE:	SIZE:	DRAWING NO.:	REV.:
CHECKED: B. Moog	DATE: 7/25/2002	D	JN10759.SCH		
QUALITY CONTROL: S. Rajan	DATE: 7/25/2002				
RELEASED: J. Mathews	DATE: 7/26/2002	SCALE: NTS	SHEET: 12	OF 15	

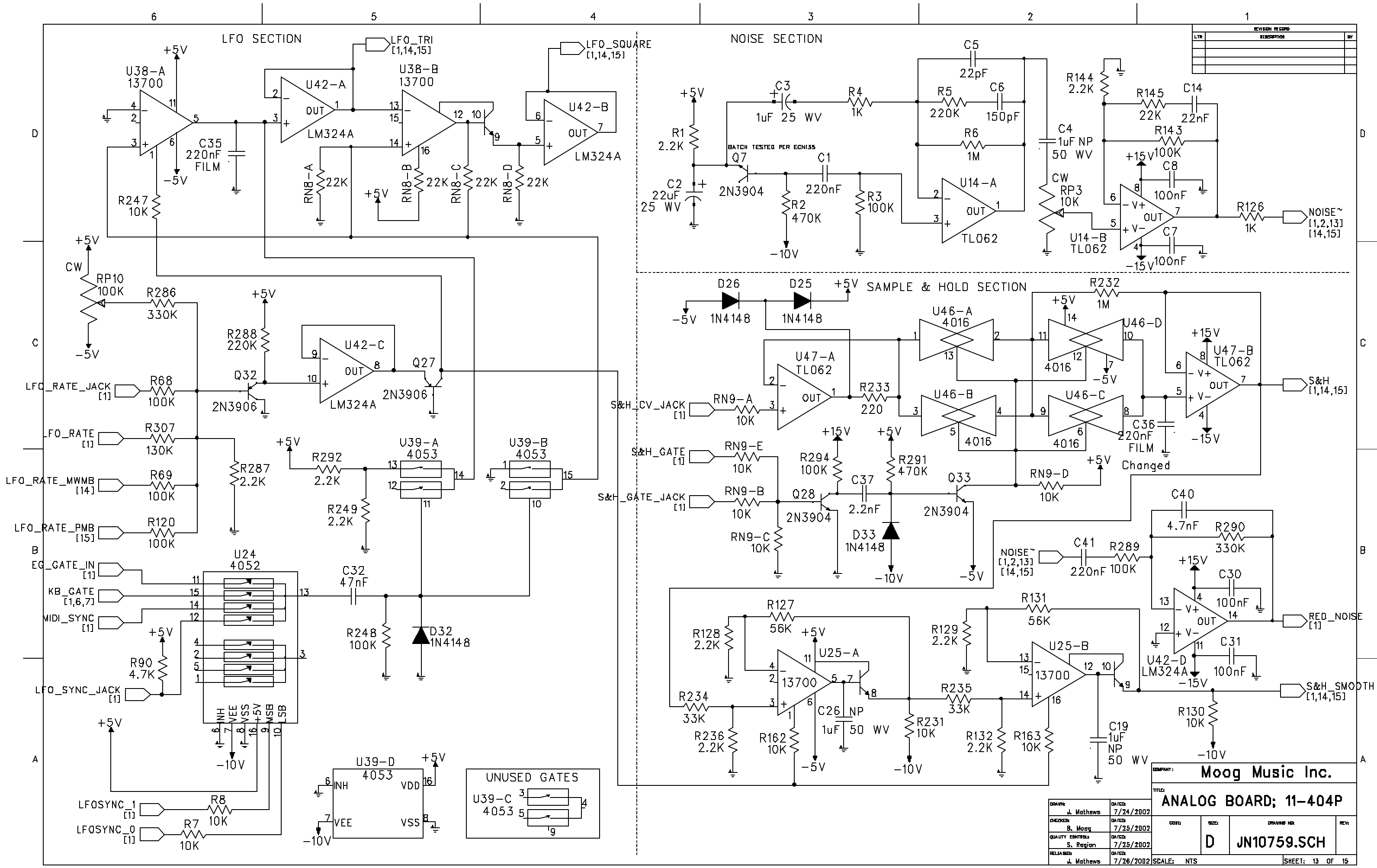

REVISION RECORD		
LT#	DESCRIPTION	BY

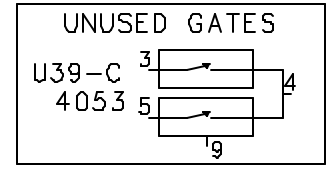

COMPANY: **Moog Music Inc.**

TITLE: **ANALOG BOARD; 11-404P**

DRAWN: J. Mathews	DATE: 7/24/2002	SCALE: NTS	SHEET: 13 OF 15
CHECKED: B. Moog	DATE: 7/25/2002		
QUALITY CONTROL: S. Reagin	DATE: 7/25/2002	DRAWING NO: D JN10759.SCH	
RELEASED: J. Mathews	DATE: 7/26/2002	REV:	

WHEEL MOD BUSS

REVISION RECORD		
LT#	DESCRIPTION	BY

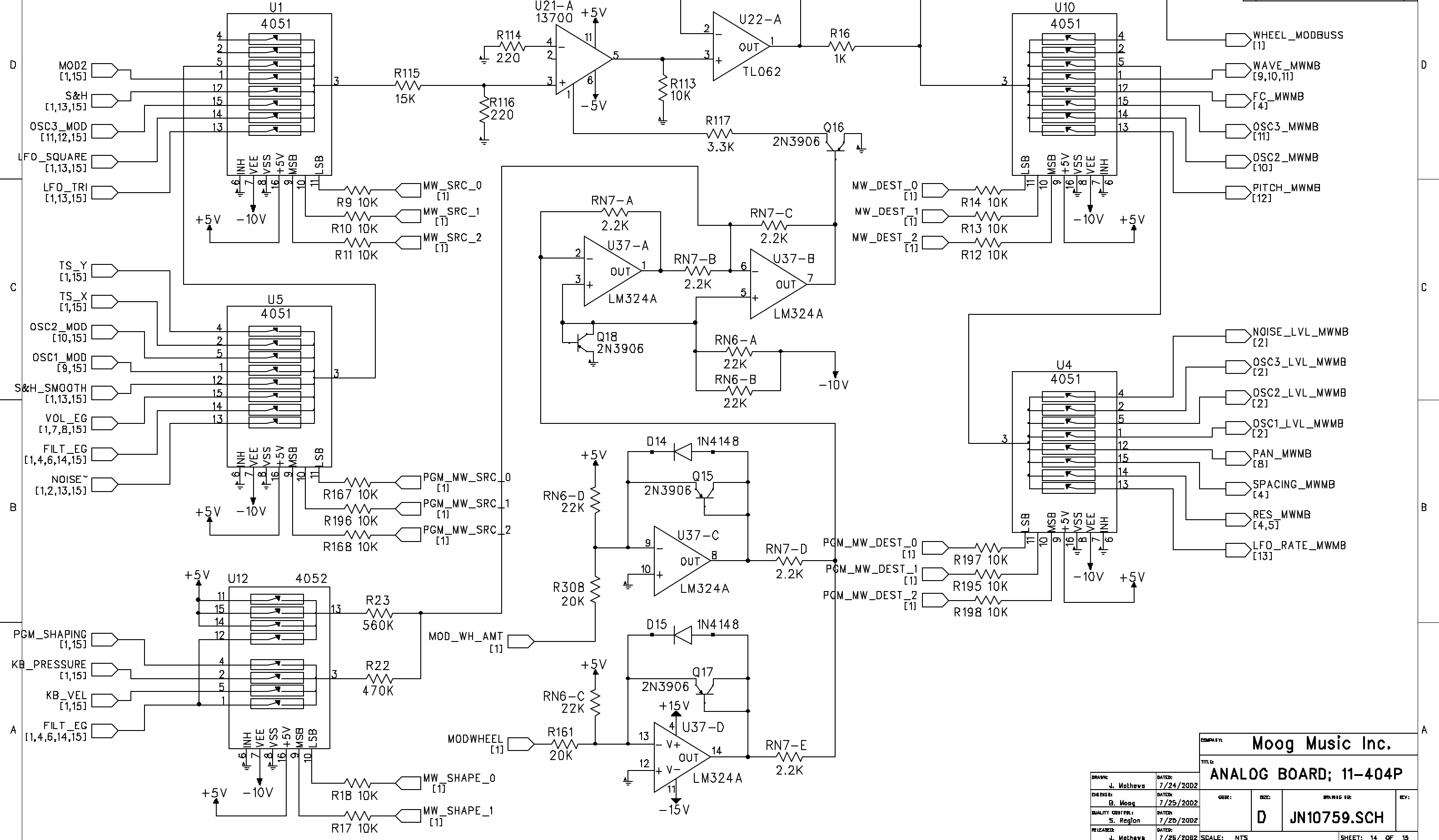

COMPANY: **Moog Music Inc.**

TITLE: **ANALOG BOARD; 11-404P**

DRAWN: J. Mathews	DATE: 7/24/2002	QTY:	SIZE:	ISSUE NO.:	REV.:
CHECKED: B. Moog	DATE: 7/25/2002	D		JN10759.SCH	
QUALITY CONTROL: S. Regan	DATE: 7/26/2002				
RELEASED: J. Mathews	DATE: 7/26/2002	SCALE: NTS			SHEET: 14 OF 15

6

5

4

3

2

1

PEDAL MOD BUSS

REVISION RECORD		
LT#	DESCRIPTION	BY

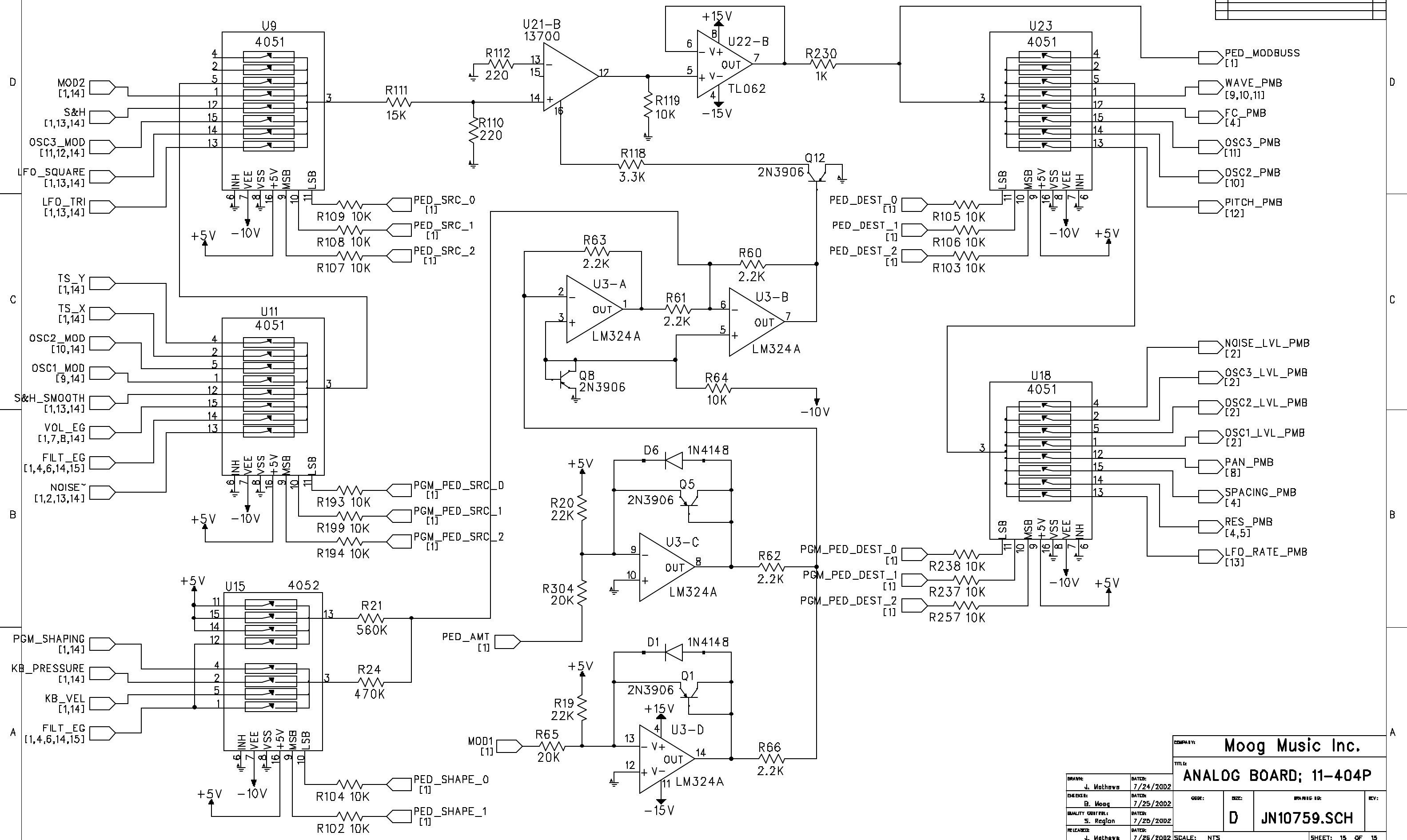

COMPANY: **Moog Music Inc.**

TITLE: **ANALOG BOARD; 11-404P**

DRAWN: J. Mathews	DATE: 7/24/2002	QTY:	SIZE:	ISSUE NO.:	REV.:
CHECKED: B. Moog	DATE: 7/25/2002	D		JN10759.SCH	
QUALITY CONTROL: S. Regan	DATE: 7/26/2002				
RELEASED: J. Mathews	DATE: 7/26/2002	SCALE: NTS			SHEET: 15 OF 15

Notes and Revisions

7/24/02: First Release

7/24/02: Omit R281, D38, Q34, R279, R282, JP3, RP1, C39, C64

Install Wire jumpers in C23 and C91. Install wire jumpers from U29-9 to U32-10 and from U7-9 to U28-10; Cut traces from U7-9, U29-9 (both component and solder side)

Install C101 to C106 on Solder side

Install C107 across R33B, C108 across R341 and C109 across R419

Install R551 and R552

2/25/03: Change R46 From 22K to 220K; R267 From 10K to 300K; R171 From 180K to 220K

3/03/03: Change RP9, RP21, RP16 to 20K; R53, R256, R453 to 95.3K

3/03/13: Changed C63, C66, C81 to Phillips Styrene 2222-424-33902

3/27/03: Change C63, C66, C81 to Panasonic ECH-S1H392JZ; R324, R375, R396 to 120K

??? Add VR1 (50K trimmer) inseries w/ R171

7/23/03: Change U56 to LMB37; U40, U50 and U52 to OP275; Install C64

7/19/04: 2N3904s used for Q7 must be tested for min 100mV noise in test circuit

8/2/04 Q1-3, Q5, Q8-10, Q12, Q14-18, Q20, Q27, Q29-31, Q35-39, Q42 Must Be Fairchild parts (2n3906) from same batch - no matching necessary

Specify Bourns only trimpots for RP2, RP9, RP16, RP21, RP11, RP14, RP18, RP20 and RP5

12/21/09 Add three jumper wires from +5V to oscillator integrator caps to prevent syncing.

REVISIONS			
REV.	DESCRIPTION	CHANGE BY	DATE
1	Prototype	xx	xx/xx/08
A	RELEASE	xx	xx/xx/08
B	.	xx	xx/xx/08

BRD-10-011-XXX

BRD-10-011-XXX

B

B

A

A

NOTES: (UNLESS OTHERWISE SPECIFIED):
 1. RESISTORS 0805, 1%, 1/BW, VALUE IN OHMS
 2. CAPACITORS 0805, X7R, 50V, VALUE IN pF

DRAFTER		DATE	THIS INFORMATION ON THIS DRAWING IS THE CONFIDENTIAL, COPYRIGHTED PROPERTY OF MOOG MUSIC INC. IT IS NOT TO BE REPRODUCED, USED, OR ENCLOSED EXCEPT TO THOSE OTHER THAN MOOG MUSIC INC. WHOSE NEED TO KNOW BASIS. RELEASE TO A THIRD PARTY IS ALLOWED ONLY WITH THE WRITTEN PERMISSION OF MOOG MUSIC INC.		
X		xx/xx/08			
DESIGN ENG.		DATE			
X		xx/xx/08			
PROJECT MGR.		DATE			
X		xx/xx/08			
MANUFACTURING		DATE			
X		xx/xx/08			
PLANT MANAGER		DATE			
X		xx/xx/08			
PURCHASING		DATE			
X		xx/xx/08			
PRESIDENT		DATE			
X		xx/xx/08			
DOC. CONTROL		DATE			
X		xx/xx/08			

MOOG MUSIC INC.		2004-E Riverside Drive		Asheville, NC 28804	
TEL: 828-251-1100		FAX: 828-251-2833		WWW.MOOGMUSIC.COM	

TITLE		Schematic / Sheet Name			
PROJECT NAME		Project Name			
REV	DATE	SCALE	ENGR	PROJECT CODE	SHEET NO.
0		N/A	X	BRD-10-011-XXX	1
SCALE		ENGR DIRECTORY		PROJECT CODE	
N/A		X		X	
				1 OF 1	

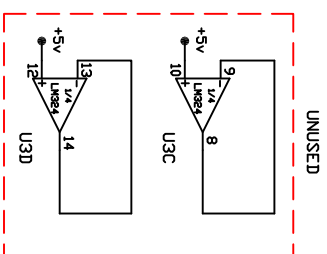
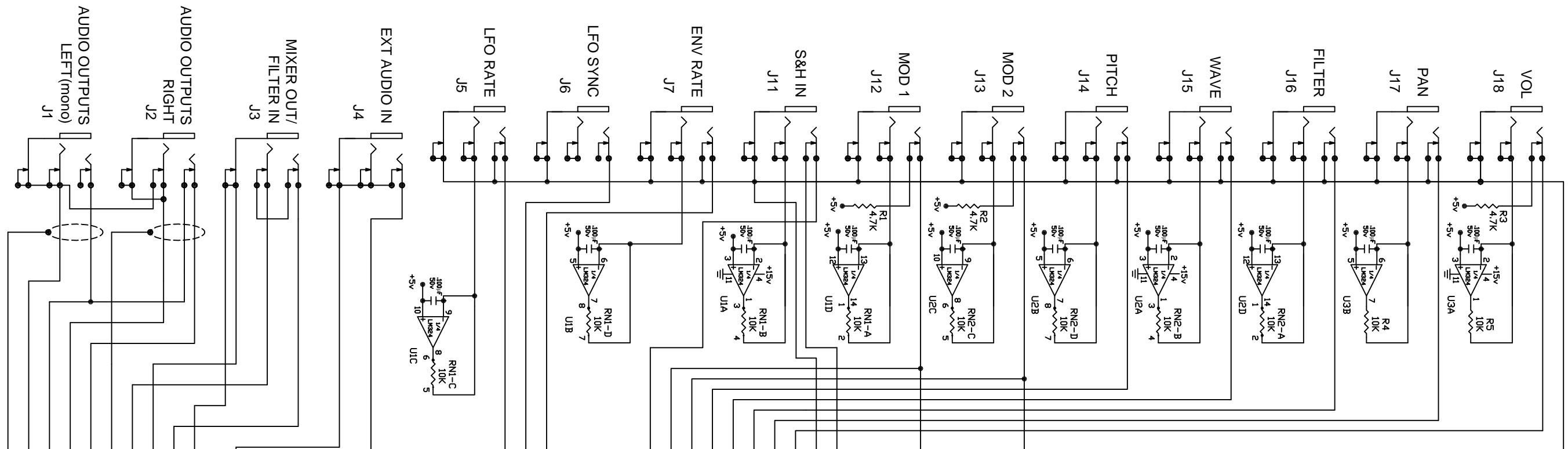

LAST COMPONENT USED:
 U3
 R5
 RN2
 J18

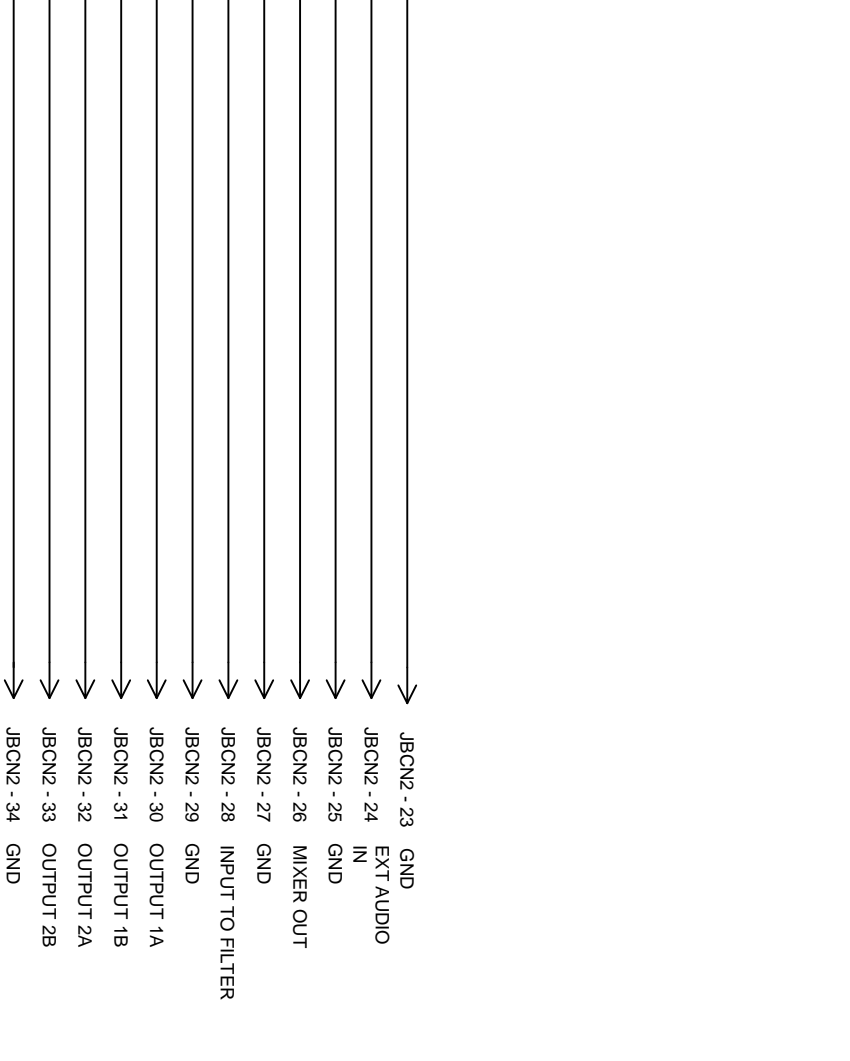
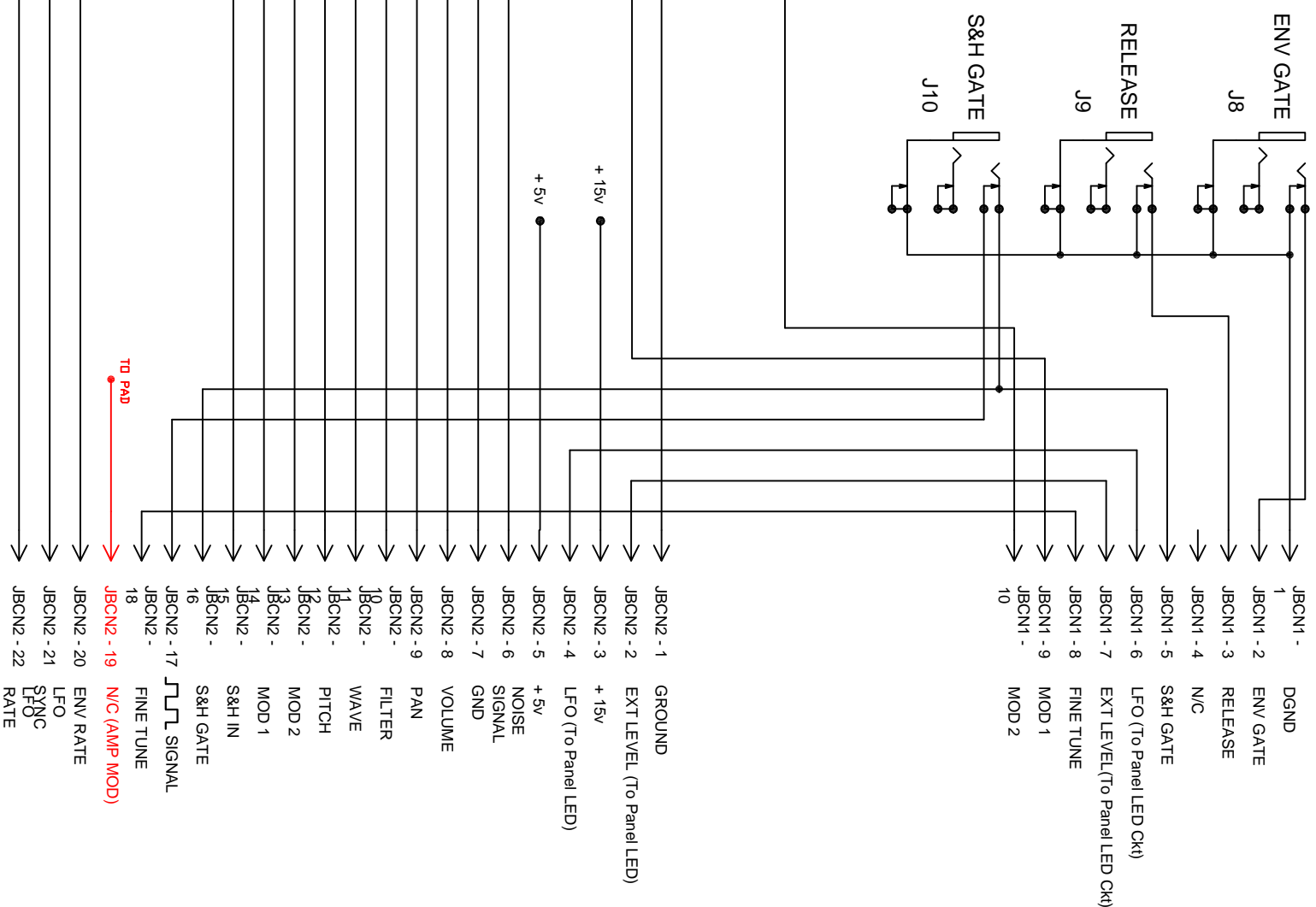

DIMENSIONS ARE IN INCHES TOLERANCE PRACTICES: * M, * F, * H, * K, * N, * P, * R, * S, * T, * U, * V, * W, * X, * Y, * Z		DIMENSIONS ARE IN MILLIMETERS TOLERANCE PRACTICES: * A, * B, * C, * D, * E, * F, * G, * H, * I, * J, * K, * L, * M, * N, * O, * P, * Q, * R, * S, * T, * U, * V, * W, * X, * Y, * Z	
UNLESS OTHERWISE SPECIFIED:			
DATE: 13 JUN 2002	DESIGNED BY: AJW	CHECKED BY: RAM	APPROVED BY: RAM
DRAWN BY: AJW			
DATE APPROVED: 13 JUN 2002			
REV: -			
PART # 11-405A			
PRODUCT NAME: mini/mog VOYAGER			
DRAWN BY: AJW			
CHECKED BY: RAM			
APPROVED BY: RAM			
DATE APPROVED: 13 JUN 2002			
REV: -			

JACK BOARD SCHEMATIC

554-C RIVERDALE DRIVE
 620-251-0090 620-254-6223 FAX

6

5

4

3

2

1

REVISION RECORD			
LTR	ECCO NO:	APPROVED:	DATE:

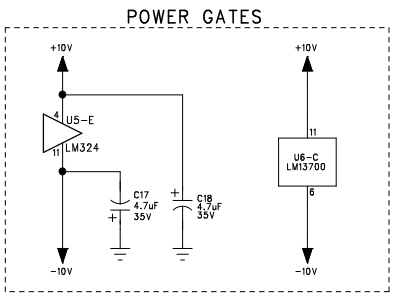
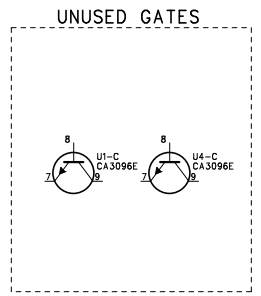
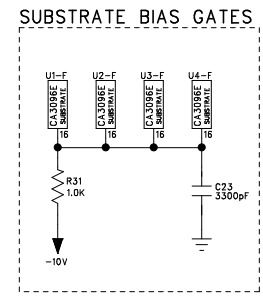
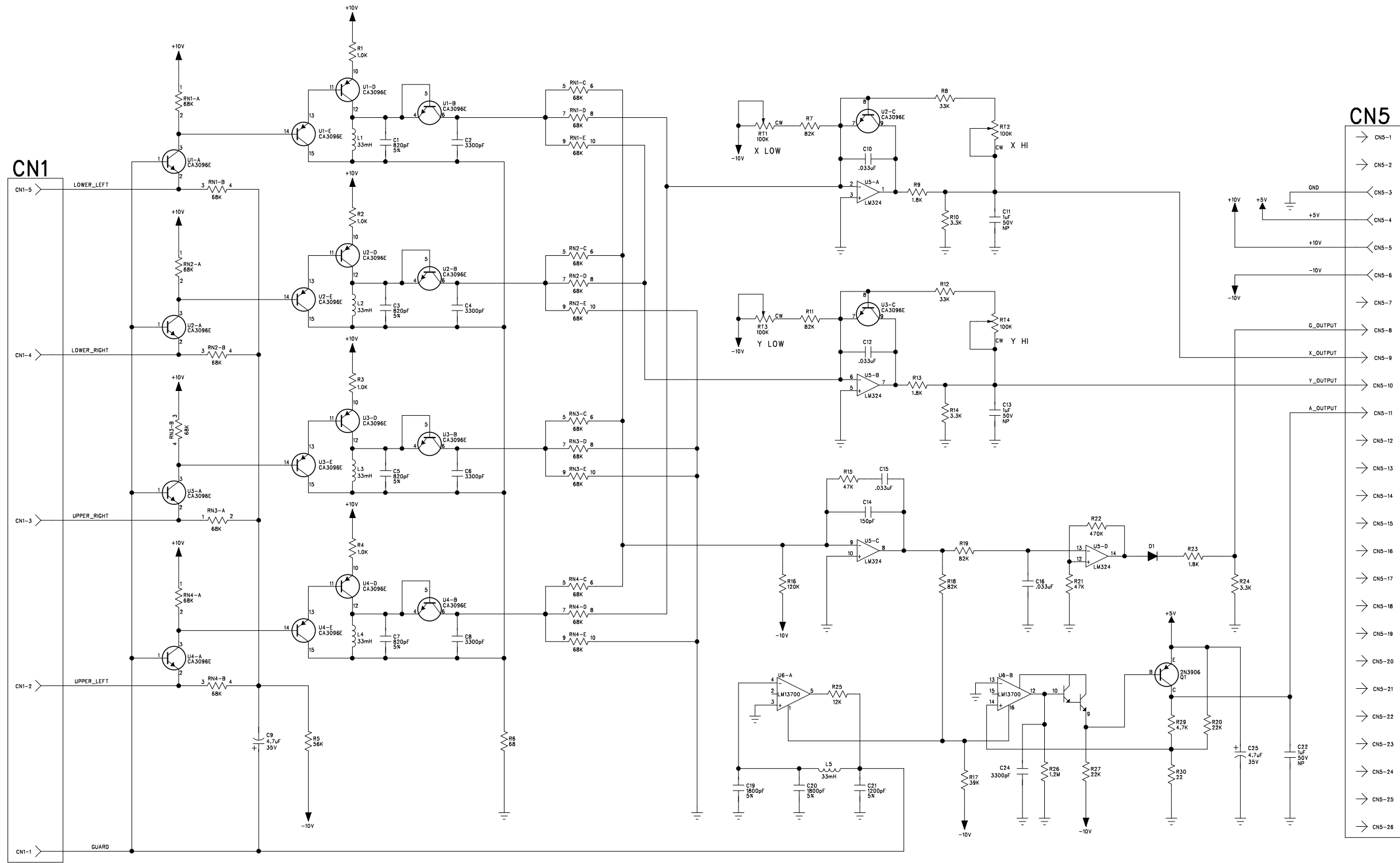

- CN5**
- CN5-1
 - CN5-2
 - CN5-3
 - CN5-4
 - CN5-5
 - CN5-6
 - CN5-7
 - G_OUTPUT
 - CN5-8
 - X_OUTPUT
 - CN5-9
 - Y_OUTPUT
 - CN5-10
 - A_OUTPUT
 - CN5-11
 - CN5-12
 - CN5-13
 - CN5-14
 - CN5-15
 - CN5-16
 - CN5-17
 - CN5-18
 - CN5-19
 - CN5-20
 - CN5-21
 - CN5-22
 - CN5-23
 - CN5-24
 - CN5-25
 - CN5-26

COMPANY: Moog Music Inc.		TITLE: 11-406A - TOUCH PLATE PCB	
DRAWN: S. Region	DATED: 7/03/02	CODE: D	SIZE: 11-406.sch
CHECKED: B. Moog	DATED: 7/05/02	DRAWING NO:	REV: A
QUALITY CONTROL: J. Mathews	DATED: 7/08/02	SCALE: NTS	SHEET: 1 OF 1
RELEASED: S. Region	DATED: 7/08/02		

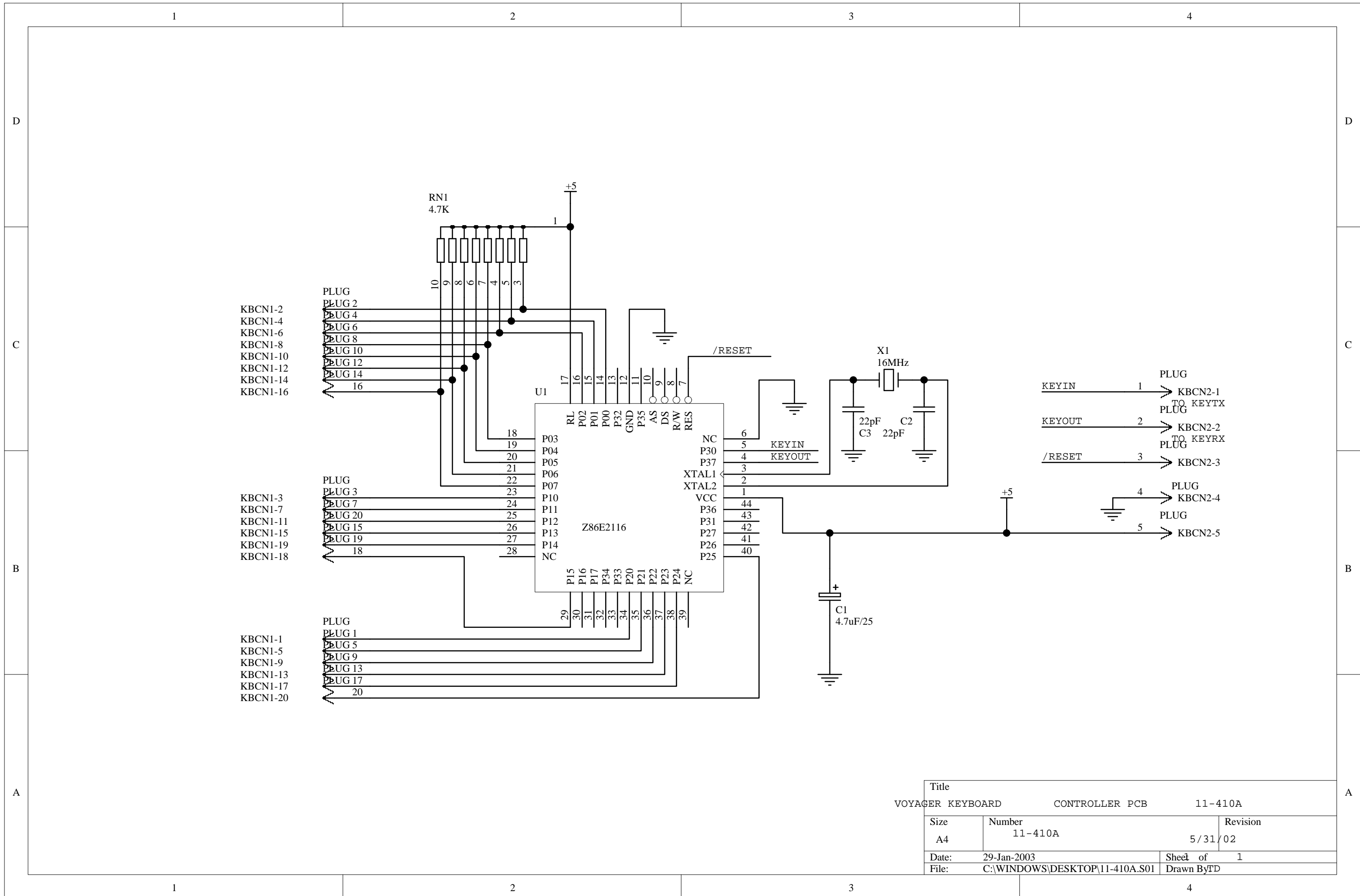

Title		11-410A	
VOYAGER KEYBOARD		CONTROLLER PCB	
Size	Number	Revision	
A4	11-410A	5/31/02	1
Date:	29-Jan-2003	Sheet	of 1
File:	C:\WINDOWS\DESKTOP\11-410A.S01	Drawn	By TD

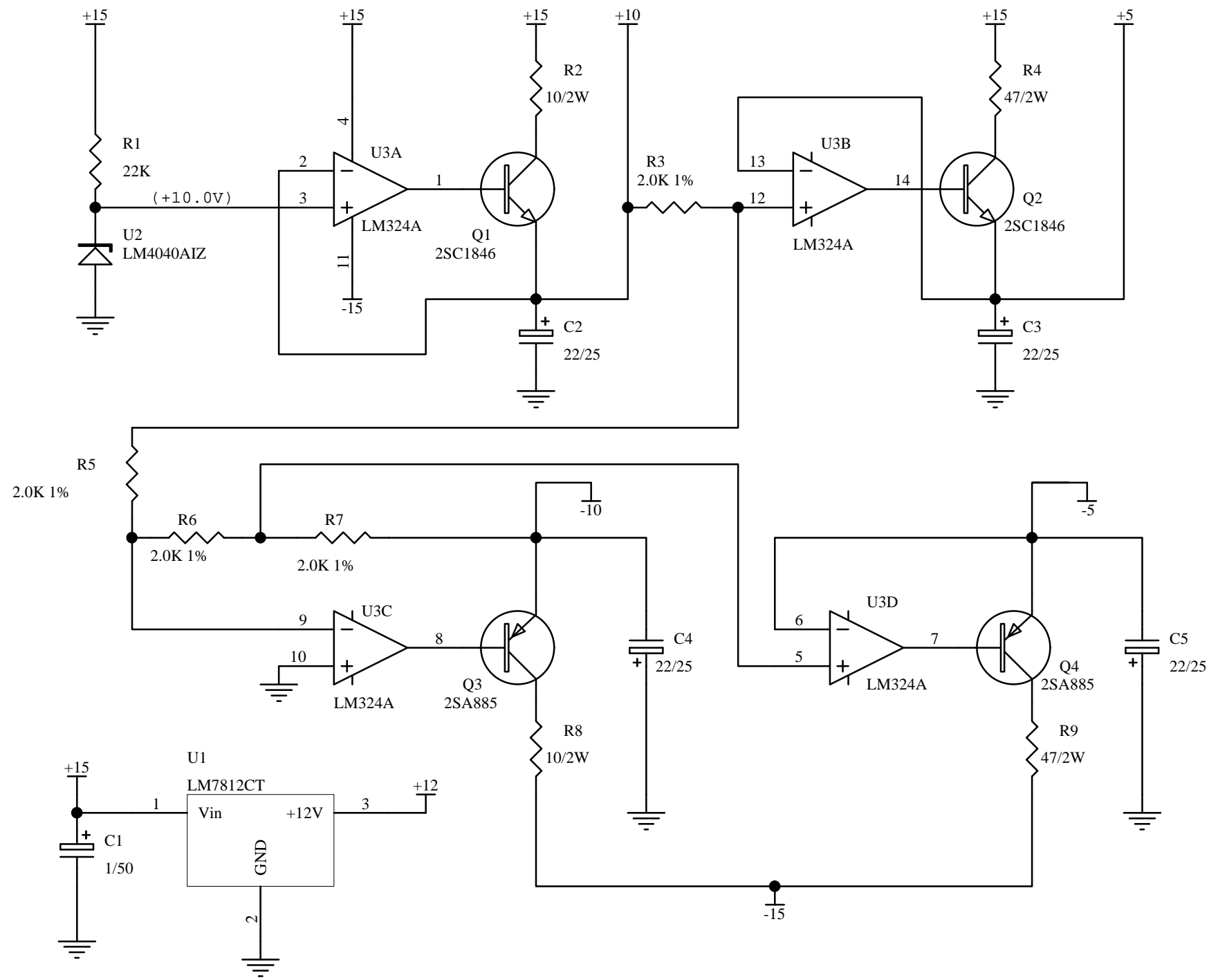

Title		
VOYAGER REGULATOR CIRCUIT		
Size	Number	Revision
A4		11-415B
Date:	29-Jan-2003	Sheet of
File:	C:\WINDOWS\DESKTOP\11-415B.S01	Drawn By: T.D.

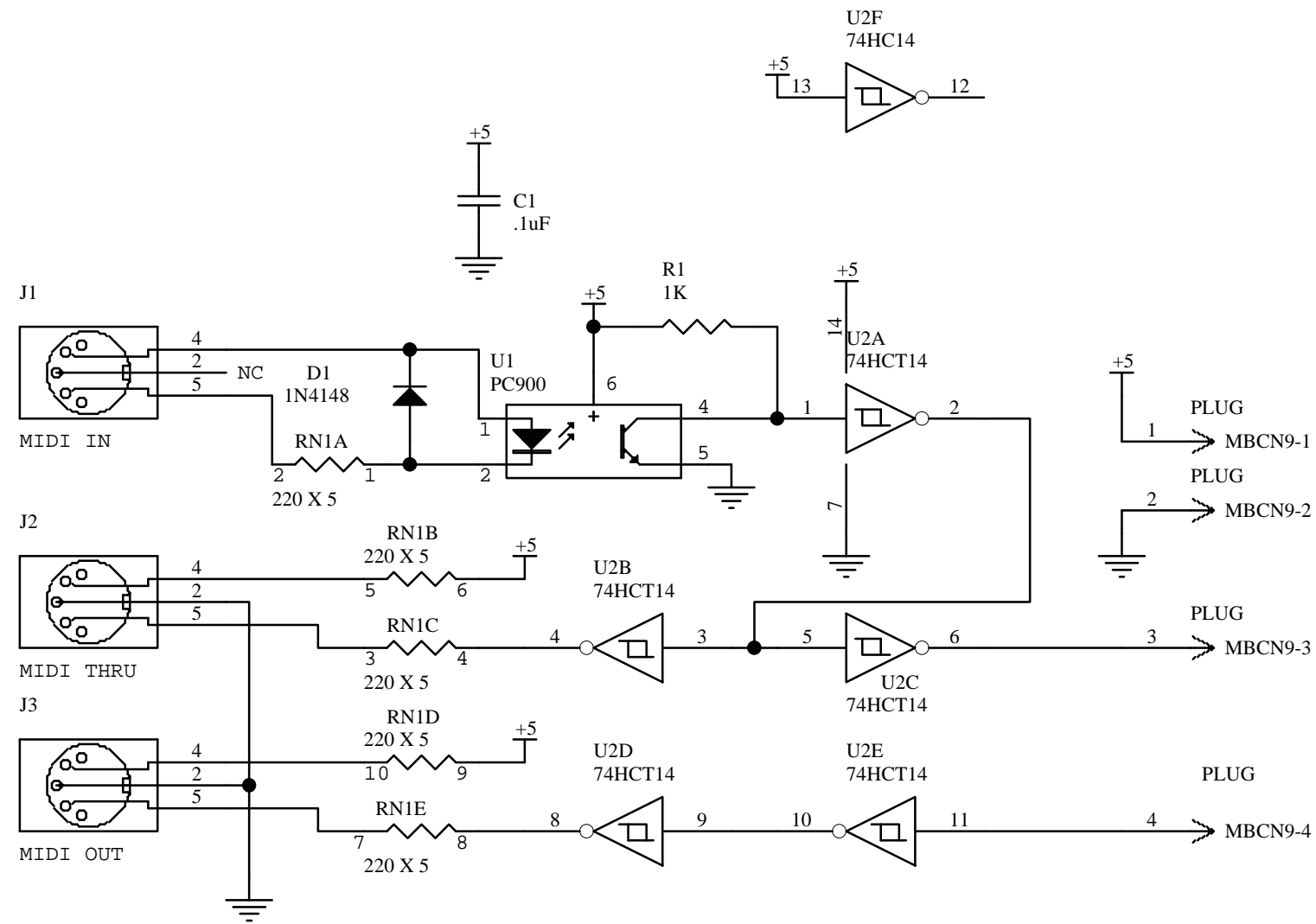

Title		VOYAGER MIDI PCB		11-420A	
Size	A4	Number		Revision	11-420A
Date:	29-Jan-2003	Sheet 1 of	1	Drawn By:	TD
File:	C:\WINDOWS\DESKTOP\11-420A.S01				

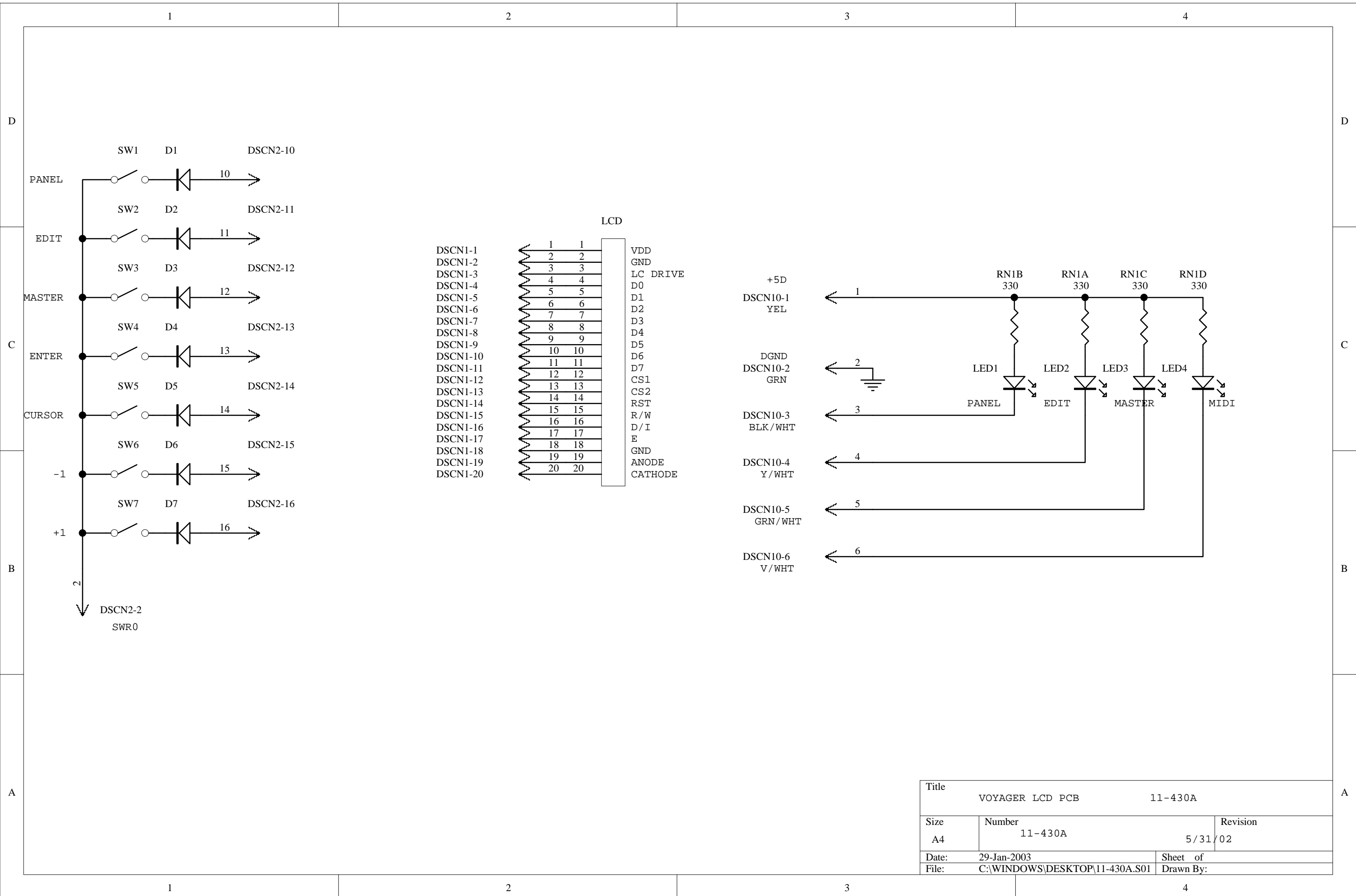

Title		VOYAGER LCD PCB		11-430A	
Size	A4	Number	11-430A		Revision
Date:	29-Jan-2003	Sheet	of		5/31/02
File:	C:\WINDOWS\DESKTOP\11-430A.S01		Drawn By:		