

SERVICE MANUAL

OB-88

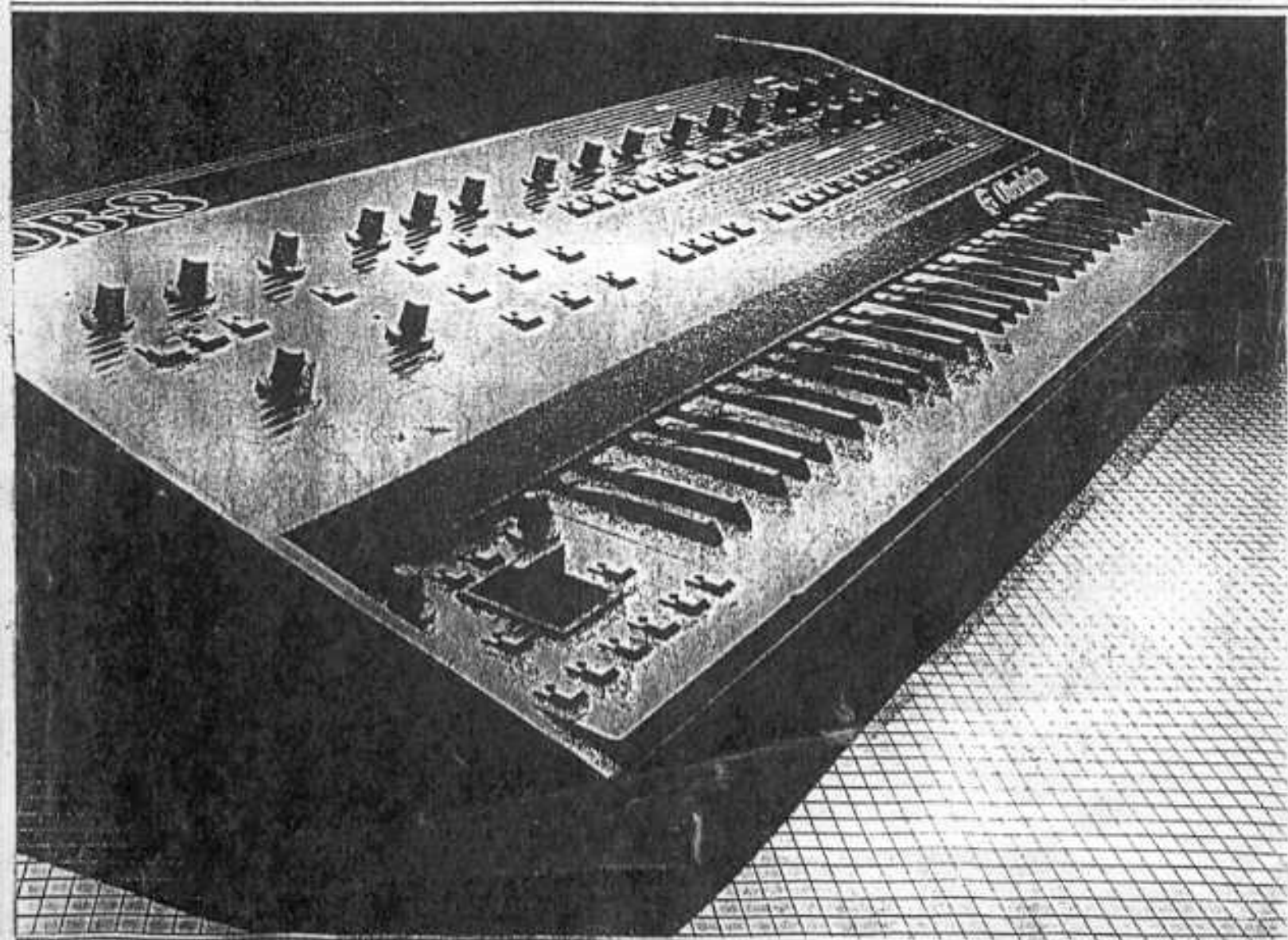



Oberheim

A Division of ECC Development Corporation
Corporate Offices: 11650 W. Olympic Blvd., Los Angeles, CA 90064 (213) 479-4948

OB-8

SERVICE MANUAL

First Edition
January 1983

This manual applies to units starting with
Serial Number C30101.

Part Number 950020

TABLE OF CONTENTS

INTRODUCTION	1
CALIBRATION	3
DAC	4
Bend Trimmers	5
Envelope Offsets	6
Oscillator Volts/Octave	8
Led Test	9
Switch Test	9
Oscillator Drift Test	10
Filter Calibration	11
Output VCA Calibration	12
FREERUNNING THE OB-8 PROCESSOR BOARD	13
CONNECTORS	14
SCHEMATICS	16
PARTS LAYOUTS	25

INTRODUCTION

INTRODUCTION

The OB-8 is the latest development in the evolution of Oberheim synthesizers. The design philosophy behind it was to take all of the features of the OB-Xe, add as many new features as were economically feasible, and redesign all of the circuitry for increased reliability and lower cost. The result is a synthesizer with 90 fewer calibrations and 11 less circuit boards, and with many of the remaining calibrations microprocessor assisted. The circuitry and the trimmers that were eliminated have been replaced with software functions in the microprocessor which simulate the replaced hardware. Some of these functions are explained below.

VCO TRACKING

The volts per octave (scaling) parameters of the 16 oscillators in the OB-8 are adjusted by the microprocessor whenever the AUTO button is pressed. The processor samples 5 different frequencies for each oscillator and calculates the proper correction voltage to bring each oscillator in tune. This voltage changes depending on the final pitch desired from the oscillator. There is a rough trimmer adjustment for each oscillator's volts per octave in order to get the oscillator within the range in which the processor can calibrate it. If this calibration is out of the acceptable range, it may be noticed by either AUTO TUNE failing that oscillator, or excessive beating between it and other oscillators while it is BETWEEN half steps. The reason for this is that the processor compensates for scaling of the oscillators for each half step, requiring that the oscillator be calibrated well enough so that the tracking between half steps is a volt per octave. If this is out of calibration it can also be perceived as steps in the LFO modulation, since the oscillator will jump slightly in pitch as the modulation amount reaches each half step.

LFOs

All of the LFOs in the OB-8 are generated in software. What this means is, the voltage necessary at any given time to simulate LFO modulation is output through the DAC to whatever destination is selected. If, for example, the triangle wave of the LFO should be at its peak, then a high voltage will be output to the destination. When the LFO should ramp down, the voltage is decreased. All of the electronic switches and VCAs normally required with a hardware LFO in order to determine its destination and amplitude are eliminated since these functions are now accomplished in software.

PITCH BEND

The pitch bend and vibrato levers are scanned by the microprocessor and their relative positions are calculated to determine the voltage necessary to bend a pitch up or down, or how much vibrato to add. This eliminates all problems associated with matching 100k resistors in order to send equal voltages to all voices, op amp offsets, and scaling trimmers. There are 2 rough trimmers used to bring the levers into range so that the processor can read them. Once they are in range, the processor re-calculates the center dead-zone of each lever each time AUTO is pressed.

4-POLE FILTER

The OB-Xa had separate 2-pole and 4-pole filters for each voice, each filter utilizing a CEM3320 with different external components to implement the filter functions. In the OB-8, there is one 3320 per voice, and the external components are electronically switched to generate either a 2-pole or a 4-pole slope. This eliminates the need to calibrate the two filters separately, since they are now the same filter.

OP AMP OFFSETS

Many sample and hold op amps can affect a parameter if their offset is large. To correct for this, the processor uses a software calibration procedure described later to assist in setting the offset to 0 volts. This adjustment is most critical for the envelope time parameters, since the CEM3310 envelope chips require a control voltage range from 0 to 300 millivolts. The software is able to correct for the offsets by outputting a voltage to the sample and holds that will compensate for the offset. If an op amp has +30 millivolts of offset, the processor will output 30 millivolts less than the final voltage required for that sample and hold, effectively canceling the offset.

CALIBRATION

OB-8 CALIBRATION PROCEDURE

The following calibration instructions are those followed by the technicians at Oberheim prior to the shipment of an OB-8. The microprocessor assists in many of the necessary calibrations by indicating which direction to turn a trimmer, and indicating when a trimmer is calibrated by using the test LEDs located on the inside of the front panel circuit boards (they are visible when the lid is open). Even though these calibrations seldom need adjustment, it is a good idea to check them whenever servicing an OB-8.

A digital voltmeter with 4 & 1/2 digits is required to perform some of these calibrations. The rest can be done without any test equipment.

For access to all voices when servicing an OB-8, it is necessary to remove the right wood endbell completely and to remove the top two screws from the left endbell. The four screws holding down the circuit board with the Upper four voices should also be removed, to allow access to the Lower Voices.

The test procedures to follow assume the OB-8 has software version A4 or above. To determine the software version, press the CHORD/PAGE 2 button twice and hold it down the second time (the LED should now be lit), and while holding it, press and hold the SYNC button. The LEDs being displayed in the PROGRAMMER section now show the current version number. If the LEDs light up as version A1 or A2, a few special procedures are required which will be mentioned later in the test descriptions. For software version A3, the only difference is that the output volume offset cannot be calibrated (unless updated to A4 with ECO 410).

First, power the unit on. Verify all voltage sources (+5, -5, +15, and -15) at connectors I and J. Calibrate the +15 supply using T2 to + or -10mv. Calibrate the -5 supply using T1 to + or - 5mv. The +5 and the -15 supplies do not require calibration, but should be verified to be within + or - 5% of their rated value.

Now, enter the calibration mode by turning the TEST 1 switch on (up). This switch is located inside the synthesizer at the lower left corner of the front panel. All LEDs should now be off except for the OSC 1 MOD LED in the Bend Box. The Bend Box in conjunction with the two leds on the inside of the pot board and the first eight keys of the keyboard can now assist in many of the necessary calibrations. Each button performs a different test or calibration procedure and assists in calibrating 28 of the 56 trimmers in the OB-8.

CALIBRATING THE DAC

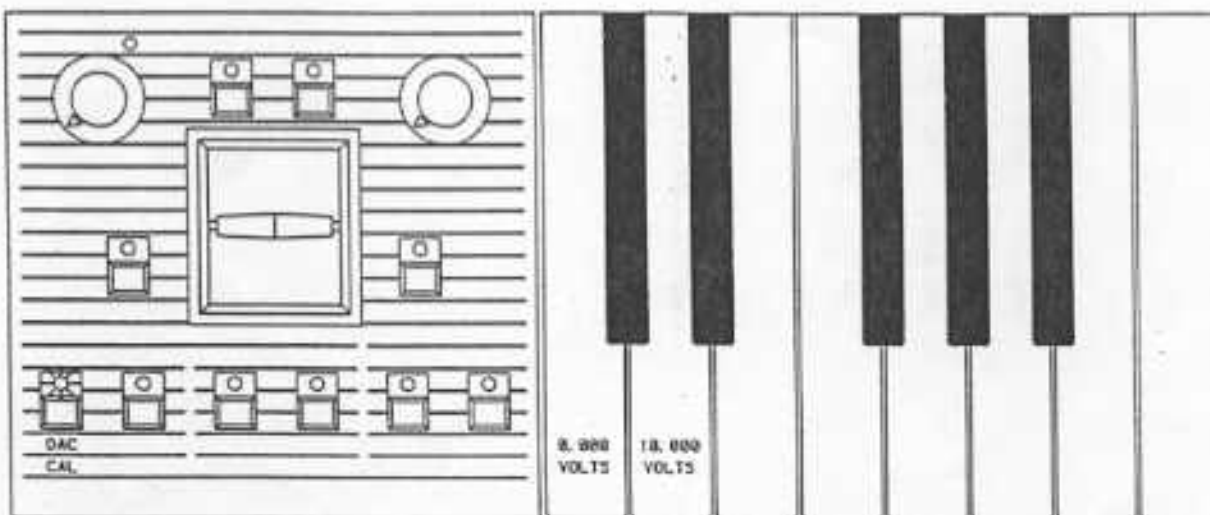

Pressing the OSC 1 MOD button in the Bend Box enables the DAC calibration mode. This procedure allows for the DAC offset and scaling to be calibrated, and should be done before any other calibrations (excluding the power supply). Connect a voltmeter to the DAC OUTPUT and AGND test points on the processor board. If there are no test points, the DAC output can be found at pin 20 of U45. Be sure to connect to a ground closest to the DAC. Press CO on the keyboard. Adjust the DAC OFFSET trimmer (T3) until the meter reads 0.000 volts. Now press DO. Adjust the DAC SCALE trimmer (T4) until the meter reads 10 volts +/- 5mv. Then press CO again and check that the meter still reads 0.000 volts and recalibrate if necessary. NOTE: The sample/holds to the attack, decay and release controls of the filter and VCA envelopes are enabled during this test so that op-amp offsets may be checked. This is necessary only if version A1 is being used. The procedure is described under SETTING ENVELOPE OFFSETS.

SETTING THE BEND TRIMMERS

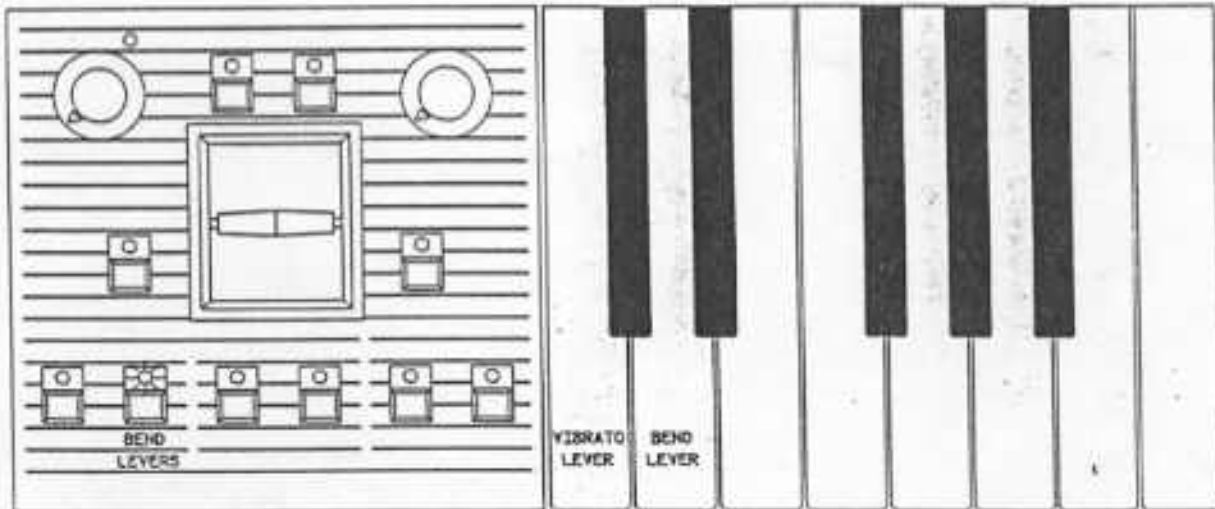

When the OSC 2 MOD switch is selected, the Bend Box trimmers can be calibrated. These trimmers are used to roughly center the Pitch Bend and Modulation Levers. First, flick the levers back and forth a little to make sure that they are in their rest position. Press CO. The LOWER LED has come on to indicate that the Modulation Lever trimmer can now be adjusted. Either one or both of the inside Pot Board LEDs (hereafter called test LEDs) will be on. If both LEDs are on, this trimmer is already properly calibrated. If only one LED is on, Adjust the RIGHT trimmer on the Bend Board until both test LEDs are on. Now press DO. The UPPER LED has come on to indicate that the Bend Lever trimmer can now be adjusted. Adjust the LEFT trimmer on the Bend Board until both LEDs are on. The Bend and Modulation Lever trimmers are now calibrated.

into memory. Now attach the DVM to U33 pin 8. Press D0. Adjust for 0.000V offset using the UPPER and LOWER buttons and write it into memory with the ARPEGGIATE button. Using the diagram as a guide, repeat this procedure for the Filter and VCA Decay, and the Filter and VCA Attack by selecting the proper parameter using the first six white keys on the keyboard. Do not adjust the Filter Sustain or the Volume Offset yet.

Now, pull up on the DEPTH knob to select the Upper Voice Board. Connect the meter to the Upper Voice Board and repeat the procedure of the Lower Board. Be sure to write each offset into memory with the ARPEGGIATE button.

After the Release, Decay, and Attack parameters have been calibrated, the Filter Sustain can be calibrated. This calibration only requires that the Upper and Lower Voice Boards be matched, but it is not necessary for them to be adjusted for 0.000 volts offset. With the DEPTH knob still pulled up, connect the meter to U27 pin 1 on the Upper Voice Board. Press B0. Adjust the offset for zero volts, or as close as it can be adjusted to zero volts. If the offset is not zero volts, remember the offset value. Write the offset into memory with the ARPEGGIATE button. Push down the DEPTH knob and connect the meter to U27 pin 1 on the Lower Voice Board. Press B0. Adjust the offset so that it is the same as the Upper Voice Board. If the offset will not go low enough, set it as low as it can go, store it in memory, and readjust the Upper Board offset to match the Lower Board.

The final offset calibration is the output volume offset. This adjustment is made to insure equal volume between Voice Boards at any volume setting. This calibration only exists in software versions A4 and above. Like the Filter Sustain calibration, the important thing is to match the 2 boards, even if they are not set for 0 offset. Make sure that the MASTER VOLUME and trimmers T501 on each Voice Board are all the way up before making this adjustment. First on the Lower Voice Board, connect the meter to U503 pin 6. This is a high impedance signal so be sure to use a shielded cable on the meter. Press the DEPTH knob into its down position and press C1 on the keyboard. Using the same procedure as for the Filter Sustain, adjust the offset until the meter reads 0.000 volts or is as close to 0 as possible. Write the offset into memory with the ARPEGGIATE button. If the offset is more than 150 millivolts, replace U503 with another 3080 and repeat the procedure. If the offset is below 150 mv but above 0, remember the offset. Repeat the procedure for the Upper Voice Board by pulling up on the DEPTH knob, pressing C1, and connecting the meter to U503 on the Upper Board. Adjust the offset so that it matches the Lower Board. If the offset cannot be adjusted low enough, set it as low as it will go below 150 mv (otherwise it should be replaced), write it into memory with the ARPEGGIATE button and reset the Lower Board so that the offset matches the Upper Board. Write the new offset into memory. After all of the offset calibrations have been completed, press down on the RATE knob.

OSCILLATOR VOLTS PER OCTAVE ADJUSTMENTS

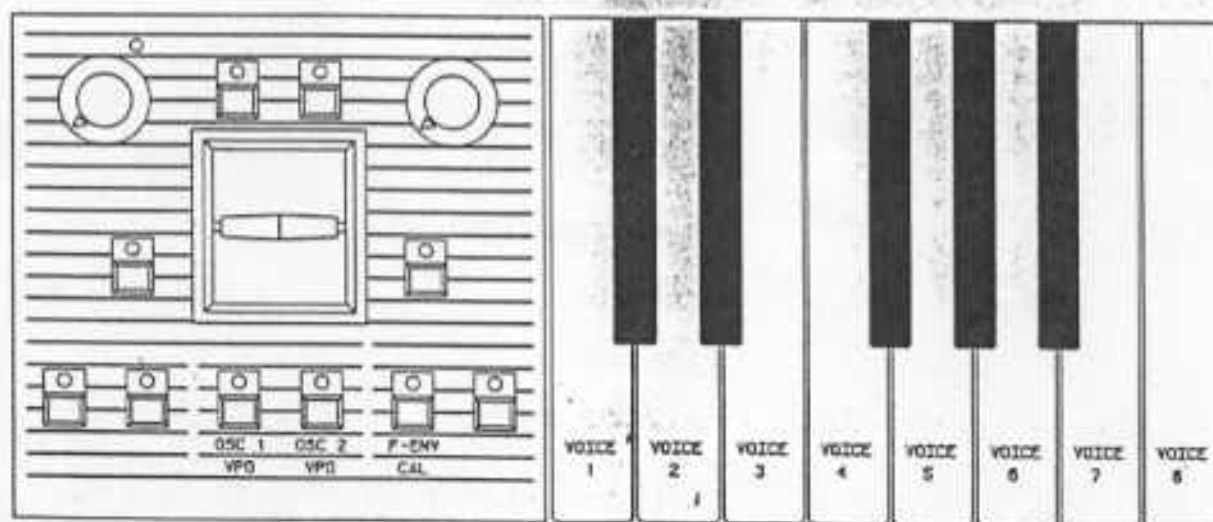

To calibrate the volts per octave of oscillator 1 of each voice, press the OSC 2 ONLY button. The voice to be calibrated is selected using the first 8 white keys on the keyboard (C0-C1). The gate LED will be lit on the voice that is currently selected. Select voice 1 by pressing C0 on the keyboard. If both test LEDs are on, this oscillator is in calibration. If only one LED is on, adjust the volts per octave trimmer (T101) until both test LEDs are on. If both test LEDs are off or seem to be flashing randomly, then this oscillator is not functioning properly and should be repaired or replaced. Select D0 now to calibrate voice 2 and repeat the procedure stated above for voices 2 through 8 using trimmers T201, T301, T401, etc. After calibrating all 8 voices, both test LEDs should be on whenever pressing any of the first 8 white keys. To calibrate oscillator 2 of each voice, press the BEND AMOUNT button. Follow the procedure for calibrating oscillator 1 using the first 8 white keys to select which voice is being calibrated. Adjust oscillator 2's volts per octave trimmers (T103, T203, T303, etc.) until all 8 voices are calibrated. To calibrate the amount of filter envelope modulation into oscillator 2, press the DOWN TRANSPOSE button and select a voice using the first 8 white keys. Adjust the F-ENV trimmer for each voice (T102, T202, etc.) until both test LEDs are on. Again, if both test LEDs are off or flashing randomly, oscillator 2 of the selected voice is not functioning correctly. NOTE: The volts per octave for Osc 2 and the envelope offsets must be calibrated before this adjustment is made. Also, on software version A1 and A2, the F-ENV calibration may not be able to be calibrated so that both LEDs are always on. This is due to the temperature instability and the nonlinearity of the CEM3360 VCA on each voice (U109). If this is a problem, it can be rectified by implementing ECOs 405 and 406 and replacing the eeproms (U21-U24) with the most recent version of software. This change requires many cuts and jumpers as well as component value changes and should only be attempted if absolutely necessary.

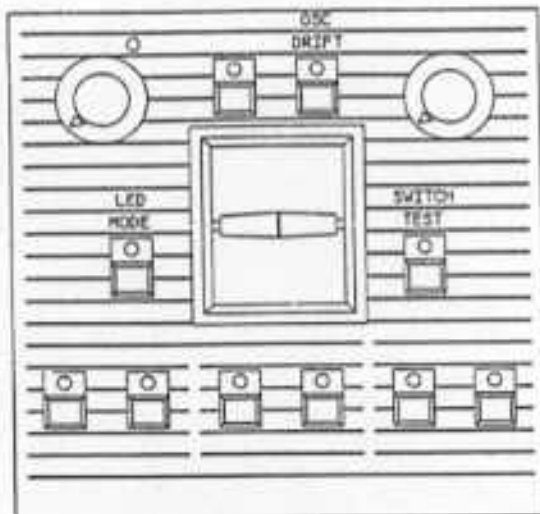

LED TEST

To test all of the LEDs, press the MODE button. This test will turn on all of the LEDs on the front panel and in the Bend Box except for the CASSETTE LED which must be turned on with the Cassette Enable switch. Any LEDs that do not light are not functioning properly. To leave this mode, select another test.

SWITCH TEST

Enter the switch test mode by pressing the ARPEGGIATE button. When in the switch test mode, each switch on the front panel will light its respective LED when pressed. The AUTO switch will light the detune LED. This test, in conjunction with the LED test, can be used to determine whether a switch or a LED is not functioning. To leave this mode, select another test.

REMAINING BEND SWITCHES

The remaining Bend Box switches (LOWER, UP TRANSPOSE) do not currently have any test function and will be ignored when pressed. These switches have been left for possible future test procedures.

All of the microprocessor assisted calibrations and tests have now been done. Return the synthesizer to its normal operating mode by turning the TEST 1 switch inside the front panel to its off position before performing the following calibrations.

FILTER CALIBRATION

There are three more calibrations necessary per voice before the voices are calibrated, and these are for the filter. This calibration procedure can be done by ear, or with a strobe tuner. First, put the front panel into manual mode, and turn off all of the switches except TRACK in the filter section. Turn the RESONANCE, VOLUME ENVELOPE SUSTAIN, and PROGRAM VOL/BAL knobs all the way up, center the MASTER TUNE control, and turn everything else all the way down. Set the master volume to a desired listening level. Go into page 2 by pressing the CHORD/PAGE 2 button twice, and turn off all of the voices except the one to be calibrated by using the program 1-8 buttons. Play a note on the keyboard and adjust the resonance trimmer (T104 for voice 1) up until sound can be heard. While playing alternate octaves on the keyboard, adjust the volts per octave trimmer² (T106) until the interval is one octave. Verify this adjustment by playing notes 2 or 3 octaves apart and determining that the octaves are in tune. Next, adjust the resonance trimmer (T104) down while holding down a key until just after the filter stops oscillating. To adjust the filter initial frequency (T105), Turn on oscillator 1 and adjust the trimmer for maximum volume. This sets the filter to the same frequency as the oscillator. Repeat this procedure for all 8 voices by enabling the voice to be calibrated and following the steps stated above. After all 8 voices have been calibrated, turn all 8 voices back on and verify that all 8 voices sound the same.

OUTPUT VCA VOLUME ADJUSTMENT

The only two remaining adjustments are the final volume trimmers (T501) on each Voice Board). While listening in MONO, turn both trimmers to maximum volume (clockwise). Turn the MASTER VOLUME and the PROGRAM VOL/BAL knobs to maximum, and check for even volume between the two Voice Boards by playing through the voices and seeing if four voices are louder than the other four. If uneven, adjust the trimmer on the board that is louder to match the other. While still in mono, turn the Master volume half way up. Check for about the same volume between Voice Boards. If the difference is very noticeable, the output volume offsets may need to be calibrated. This procedure was mentioned under ADJUSTING ENVELOPE OFFSETS. If the software version is A1, A2, or A3, replace U503 on the louder board with a 3080 with low offset and recalibrate T501.

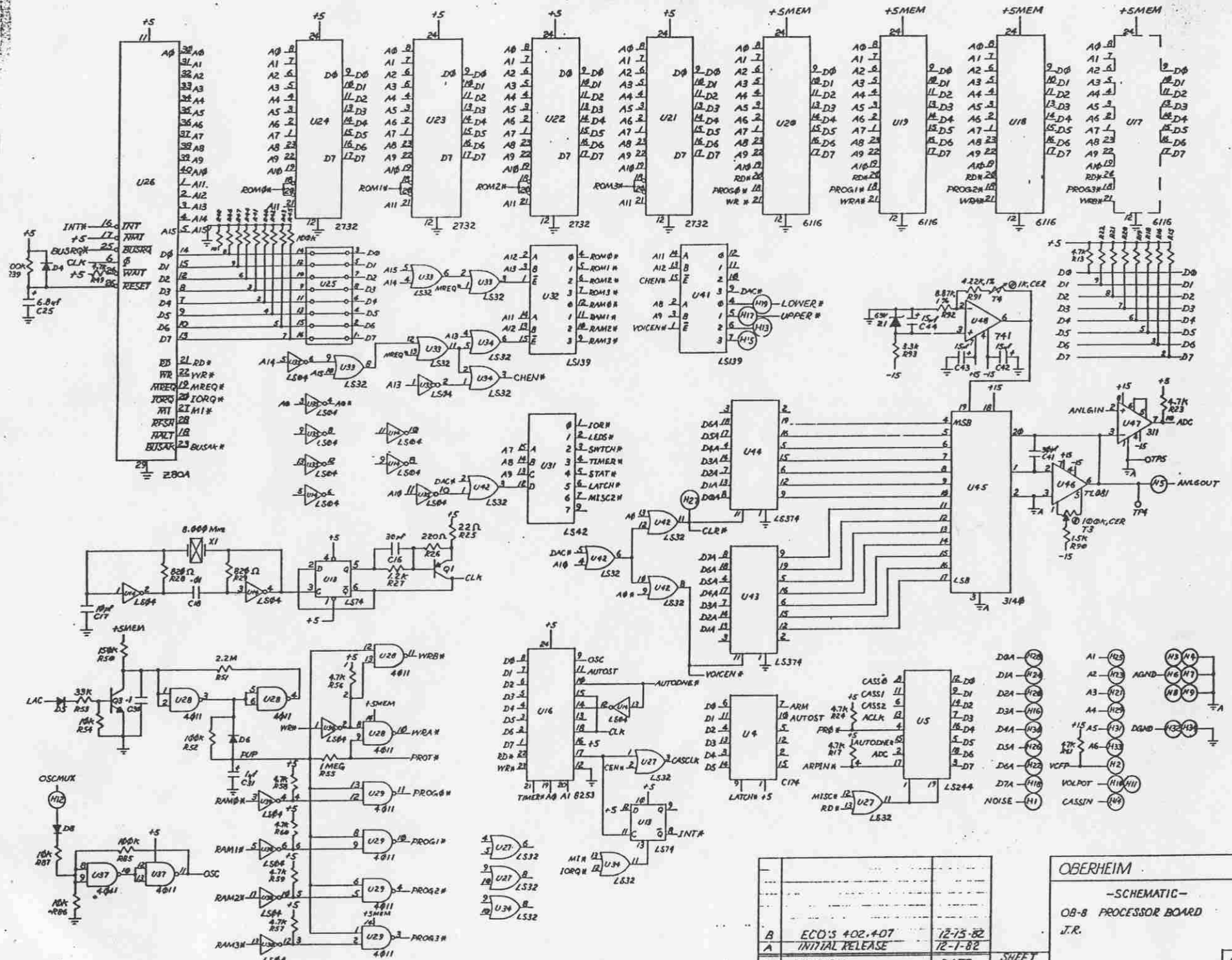

OBERHEIM			
-SCHEMATIC-			
OB-8 PROCESSOR BOARD			
J.R.			
B	ECO'S +02.407	12-75-82	SHEET 104
A	INITIAL RELEASE	12-1-82	
LTR	REVISION	DATE	1679B

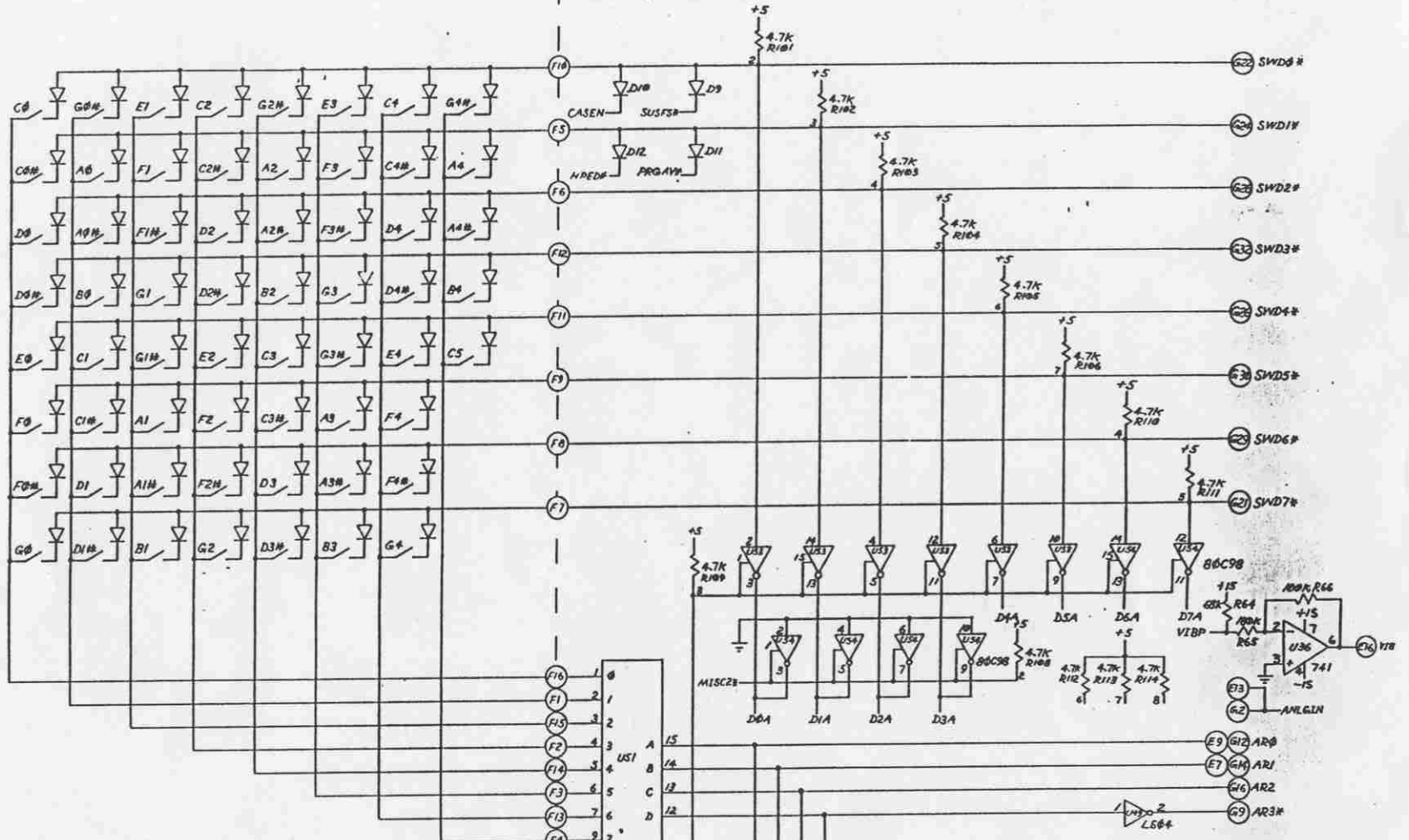

KEYBOARD

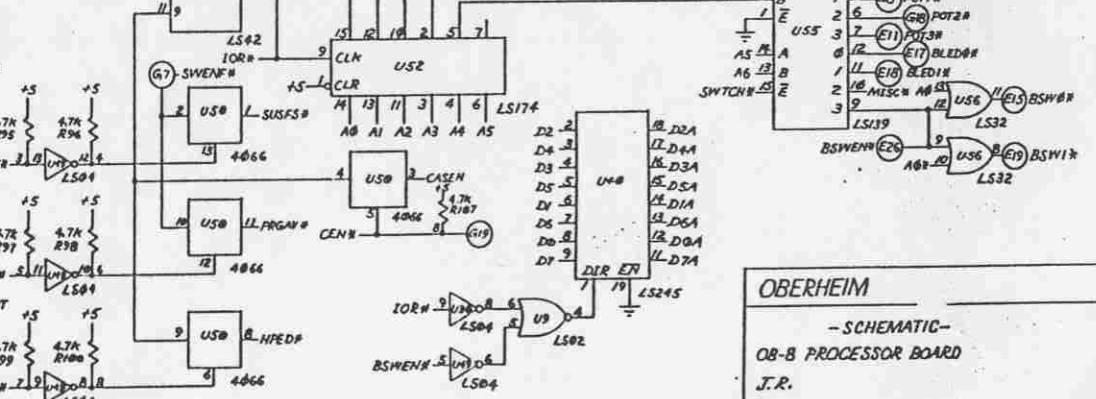
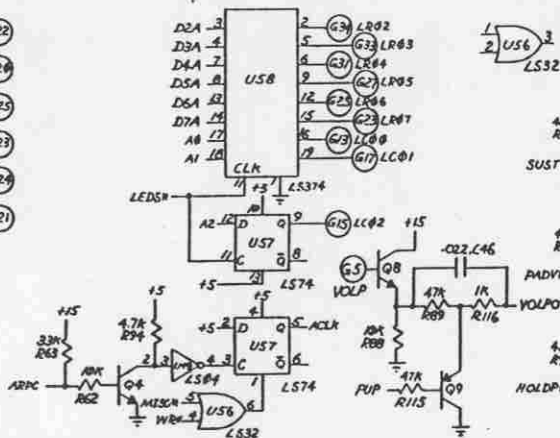
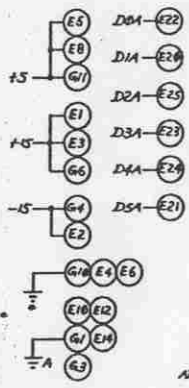

OBERHEIM
- SCHEMATIC -
OB-8 PROCESSOR BOARD
J.R.

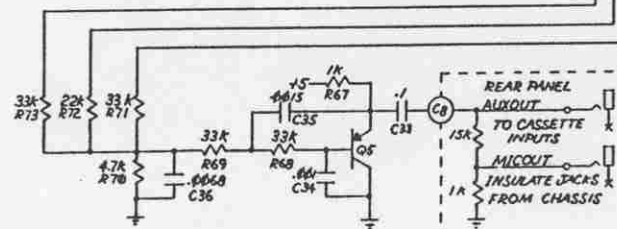
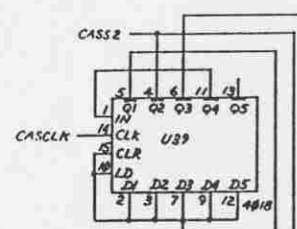
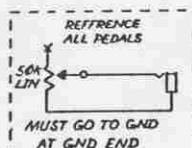
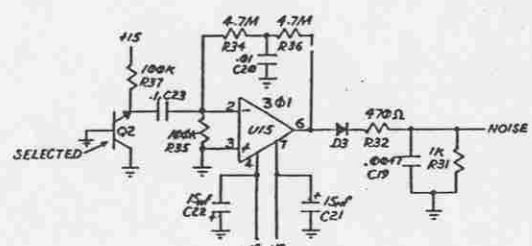
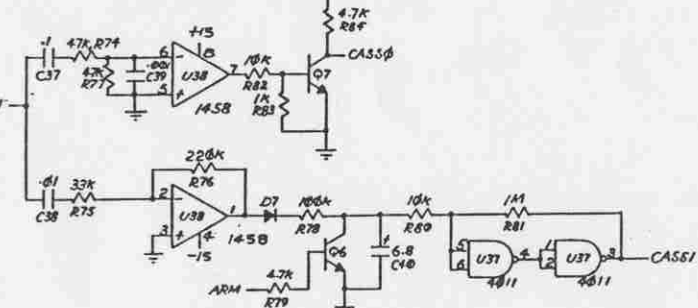
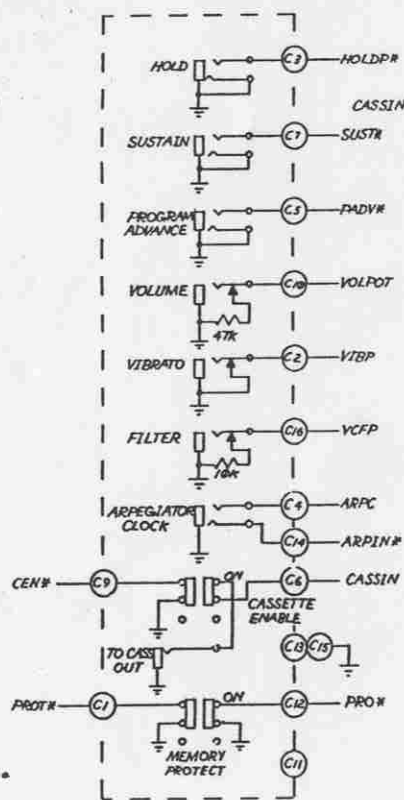
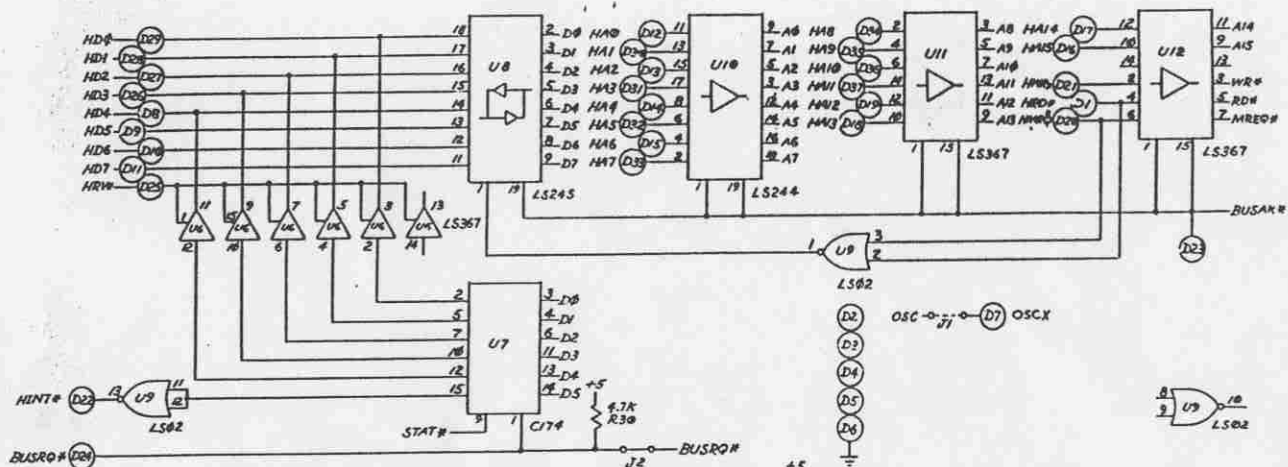

OBERHEIM
 - SCHEMATIC -
 OB-8 PROCESSOR BOARD
 J.R.

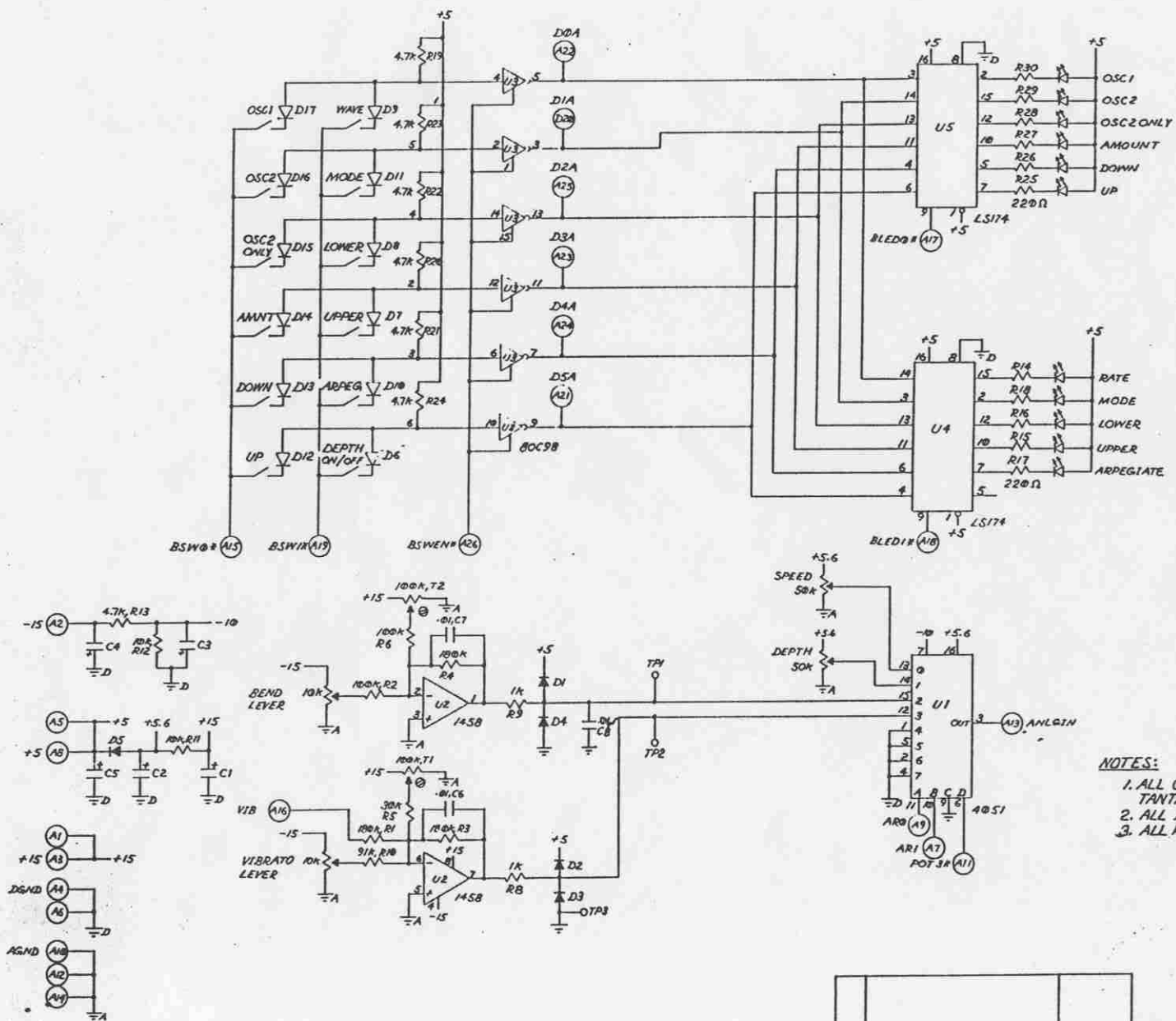

- NOTES:
1. ALL CAPACITORS, 6.8 TO 22 μ F, ARE TANTALUM OR ELECTROLYTIC.
 2. ALL DIODES ARE 1N4148.
 3. ALL RESISTORS ARE 1/4 W, 5%.

B	ECO #11	1-6-83	SHEET 1 OF 1
A	INITIAL RELEASE	12-1-82	
LTR	REVISION	DATE	

OBERHEIM
 - SCHEMATIC -
 OB-8 BEND BOARD
 J.R.

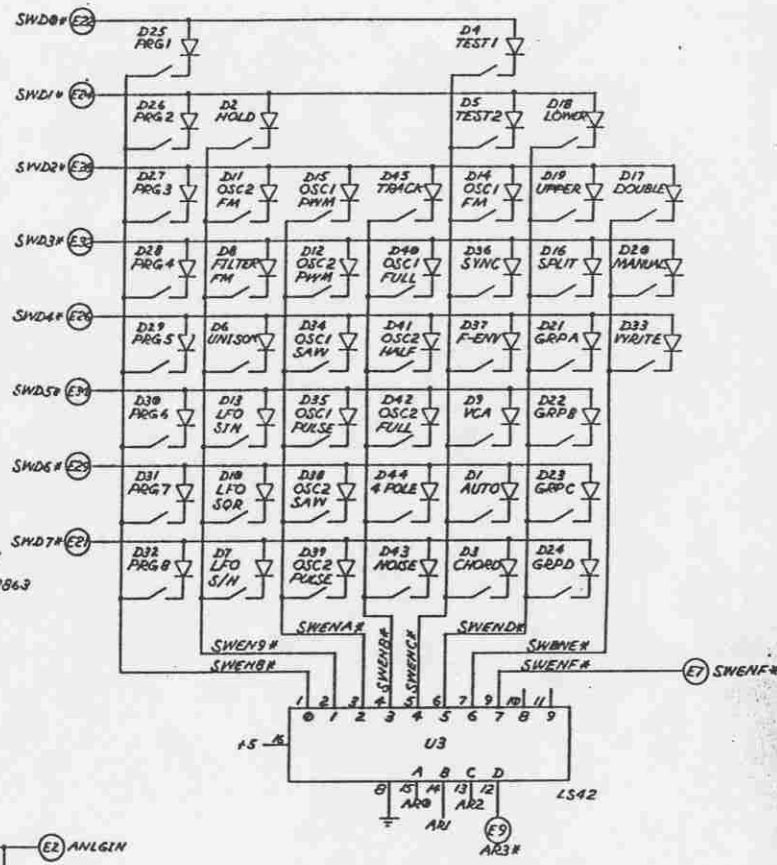
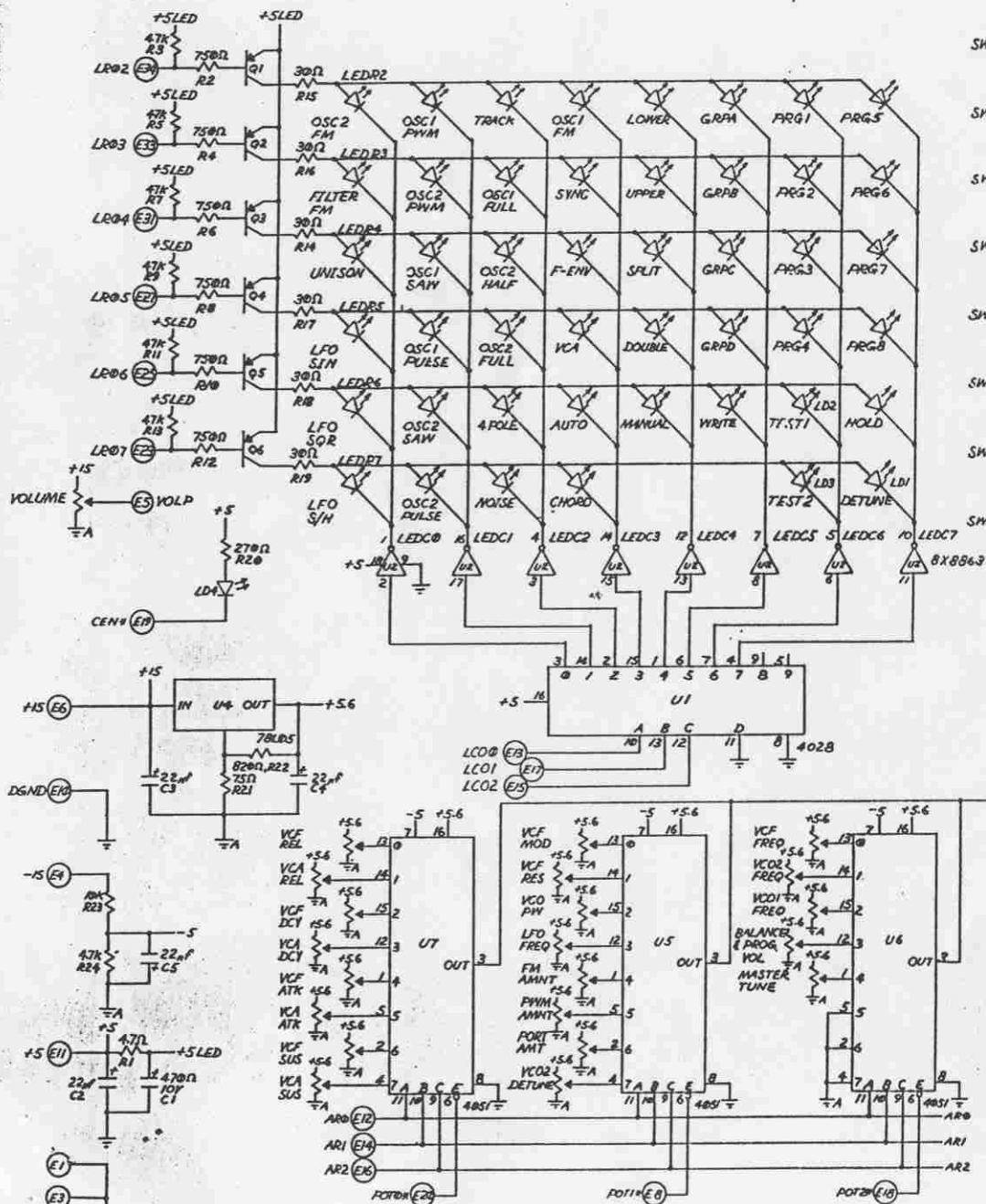

- NOTES-UNLESS OTHERWISE INDICATED:
- 1) ALL RESISTORS ARE 1/4 W, 5%.
 - 2) ALL DIODES ARE IN4148
 - 3) ALL POTS ARE 50K LIN CW4
 - 4) ALL PNP TRANSISTORS ARE 2N3638A

OBERHEIM

-SCHEMATIC-
DS-8 POT BOARD 1 & 2
J.R.

LTR	REVISION	DATE	SHEET
B	ECO 404	12-10-82	1 OF 1
A	INITIAL RELEASE	12-1-82	

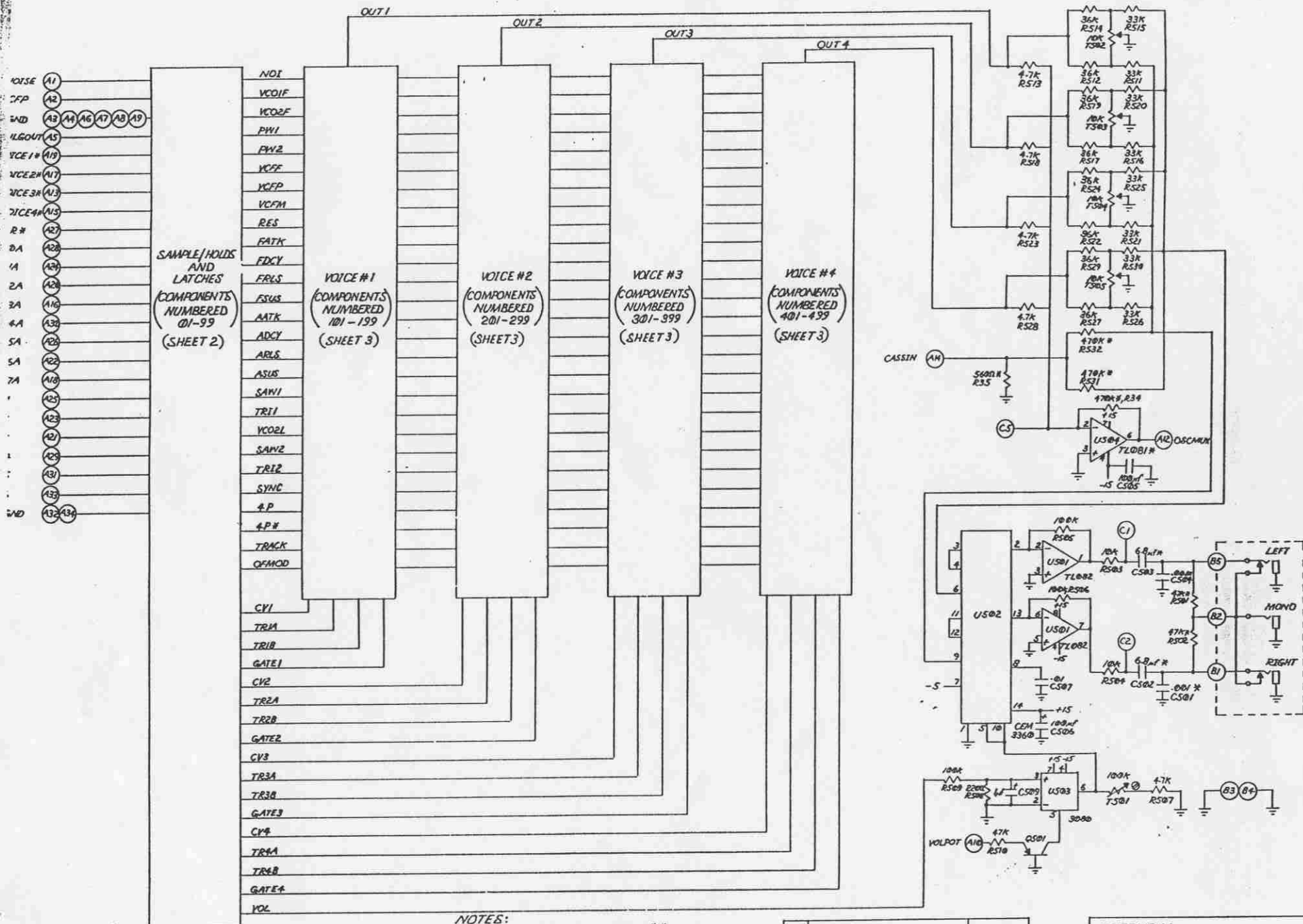

NOTES:
1. ALL COMPONENTS MARKED * ARE ON LOWER VOICE BOARD ONLY.

B	ECD'S 403,405,406,409	12-22-82
A	INITIAL RELEASE	12-1-82
ZTR	REVISION	

OBERHEIM
-SCHEMATIC-
OB-8 VOICE BOARD
J.R.
SHEET 1 OF 3
1682B

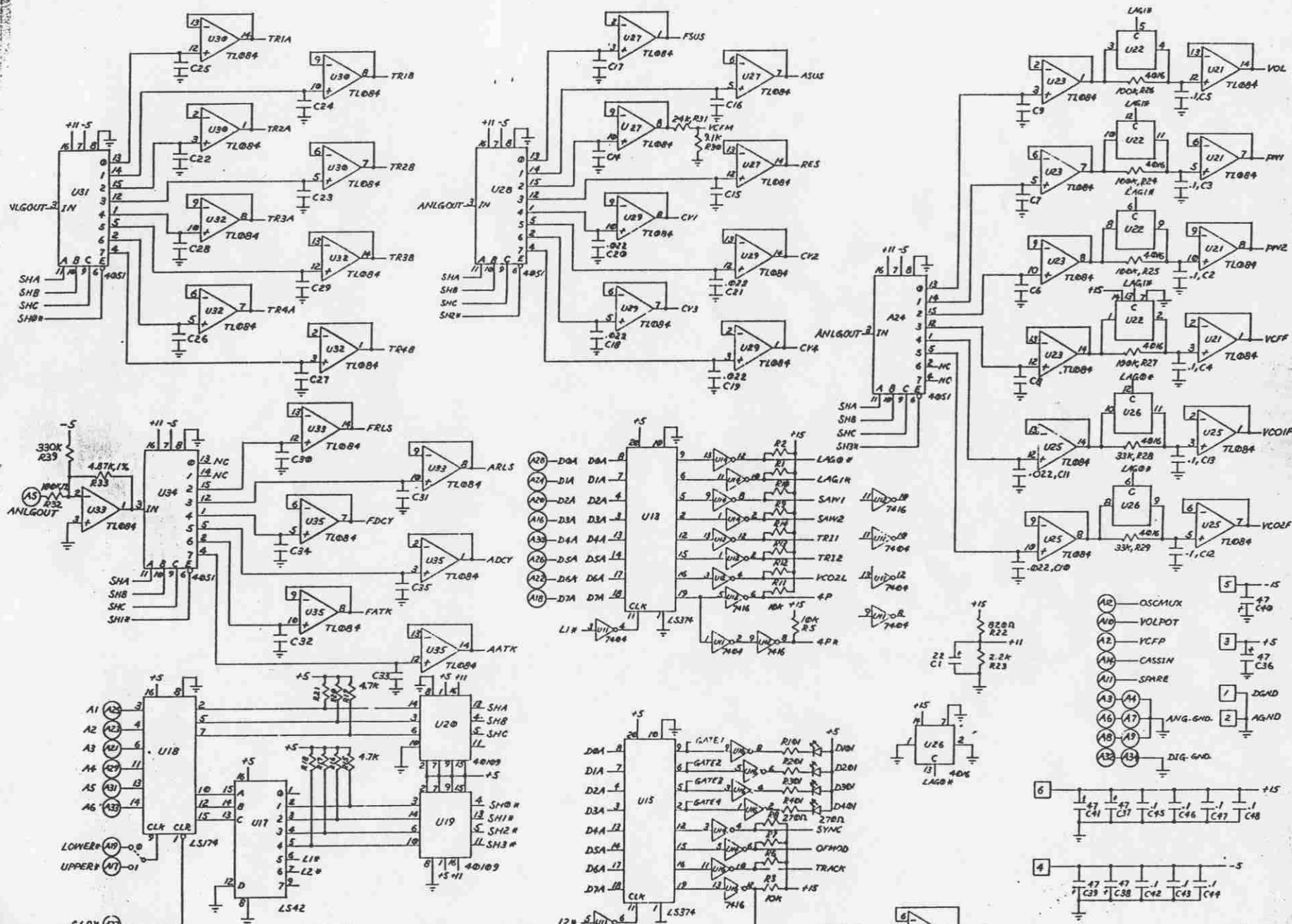

- NOTES:
1. ALL UNMARKED OP AMPS ARE TL084. SUPPLY +15/-5.
 2. ALL CAPS ARE IN MICRO FARADS.
 3. ALL RESISTORS ARE 1/4 W, 5%.
 4. ALL UNMARKED CAPS ARE .01 MF.
 5. .022 CAPS ARE POLYSTYRENE.

OBERHEIM
 -SCHEMATIC-
 OB-8 VOICE BOARD
 J.R.

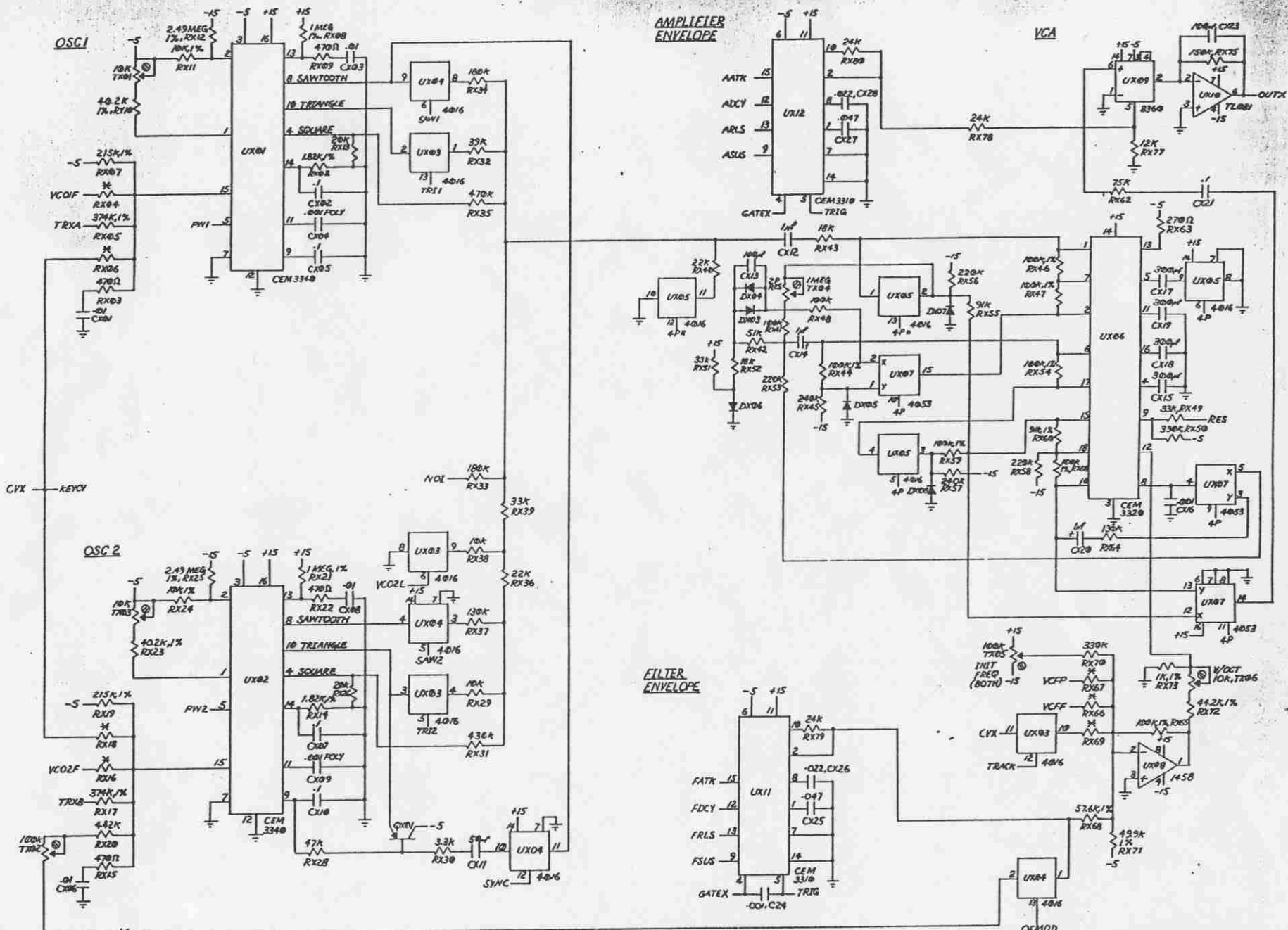

- NOTES:
1. ALL NPN TRANSISTORS ARE MPSS17Z.
 2. ALL PNP TRANSISTORS ARE 2N3905.
 3. ALL DIODES ARE 1N4148.
 4. "X" DENOTES VOICE No. (1,2,3,4).
 5. "M" DENOTES MATCHED, 100K, 1% RESISTORS.

OBERHEIM
 -SCHEMATIC-
 08-B VOICE BOARD
 J.R.

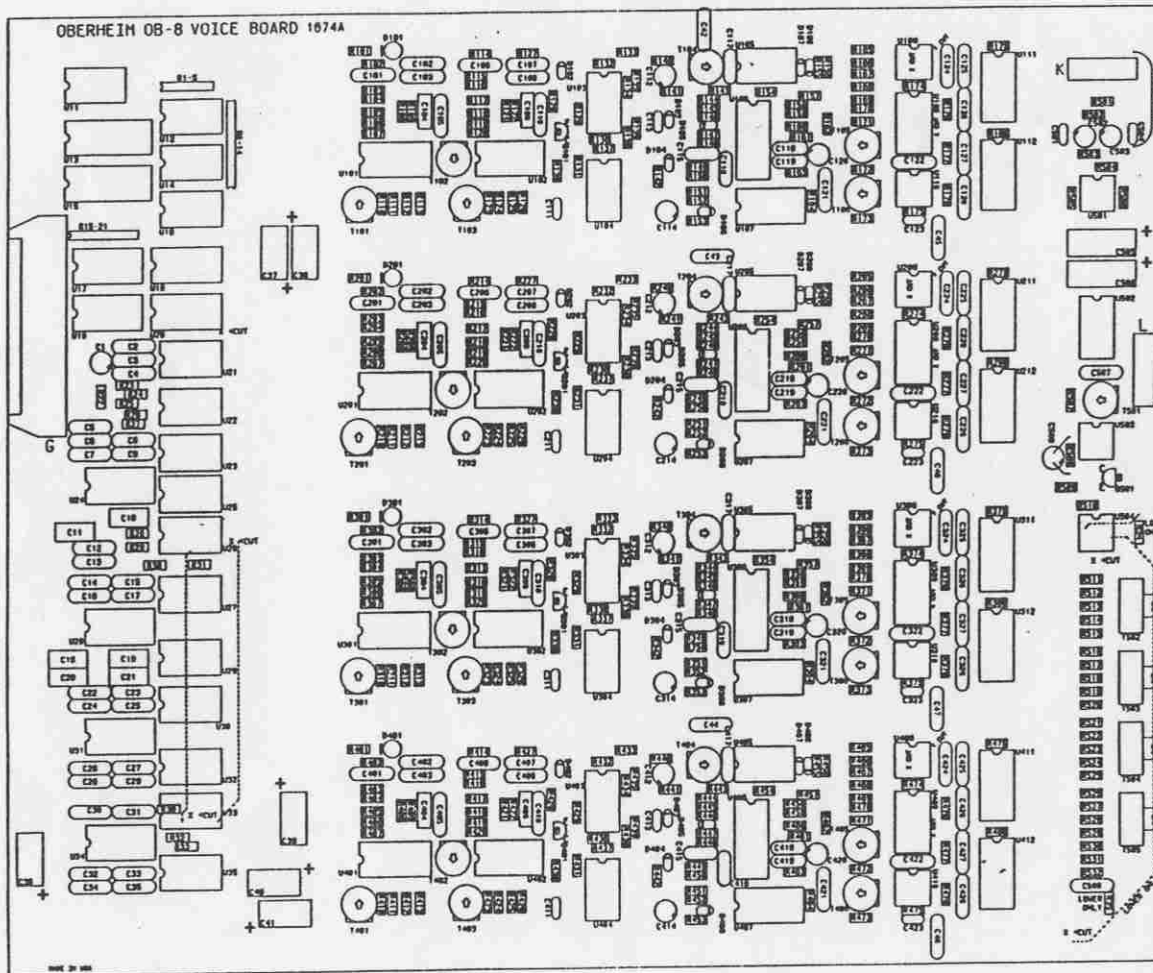

A	ECO'S 403, 405, 406, 409	12-22-82
A	INITIAL RELEASE	12-1-82
LTR	REVISION	DATE

OBERHEIM

- PARTS LAYOUT -

OB-8 VOICE BOARD

1689B

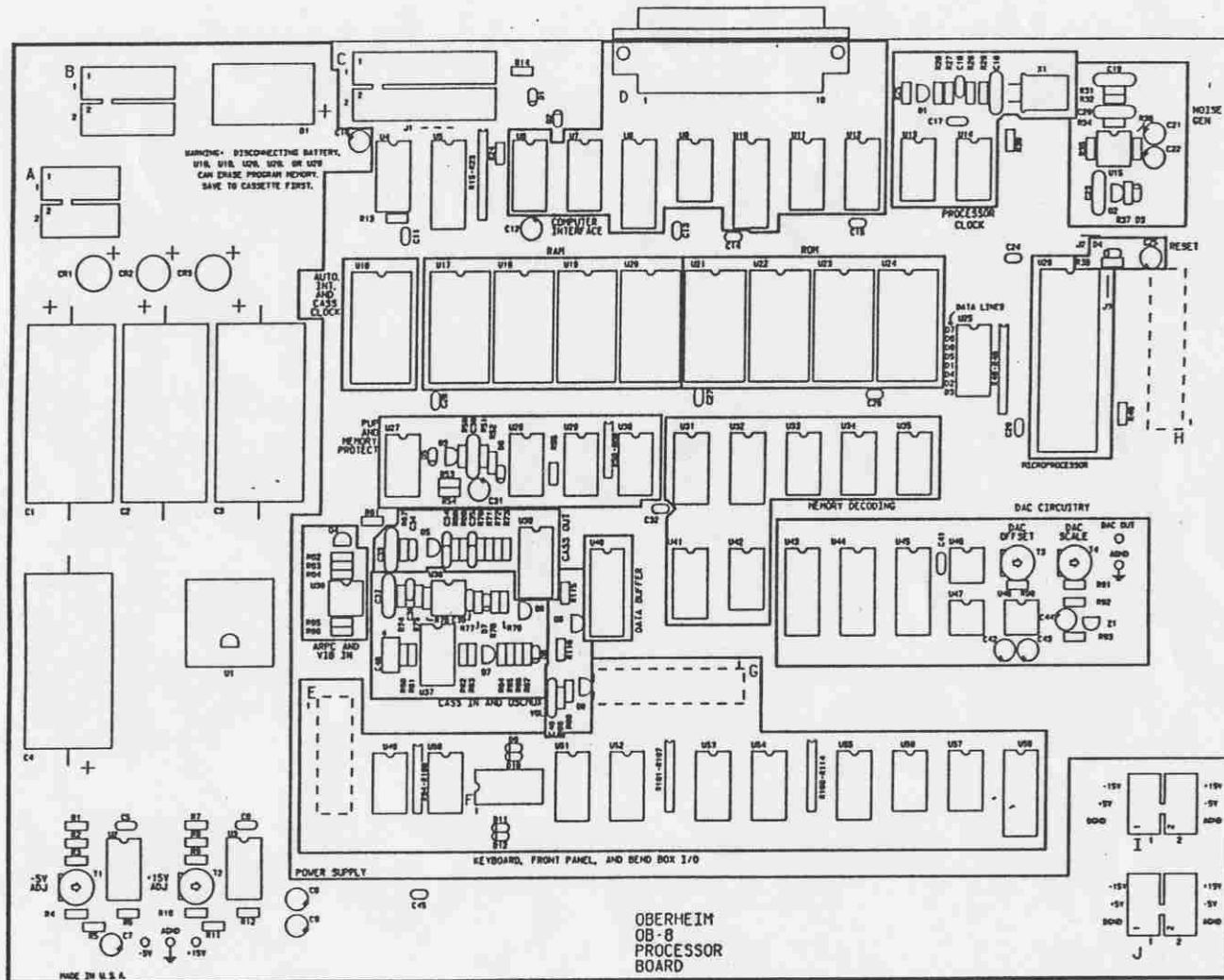

B	ECO'S 402,407	12-15-82
A	INITIAL RELEASE	12-1-82
LTR	REVISION	DATE

OBERHEIM	
- PARTS LAYOUT -	
OB-8 PROCESSOR BOARD	
1690B	

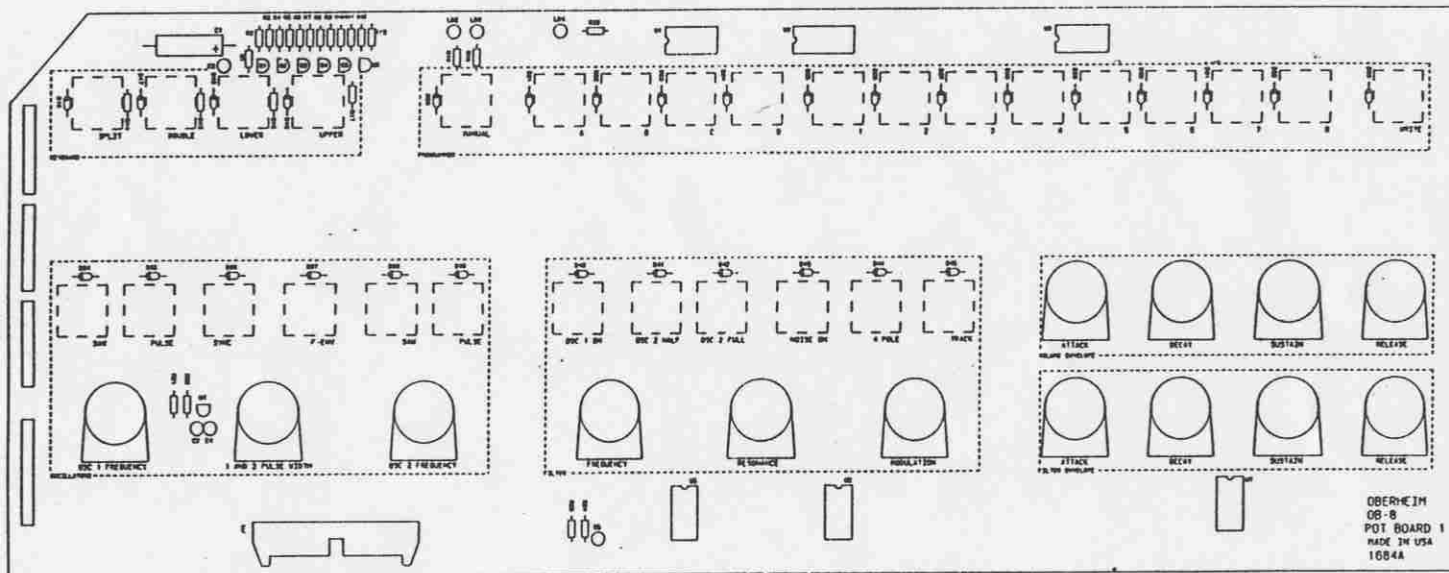

OBERHEIM
 OB-8
 POT BOARD 1
 MADE IN USA
 1684A

B	ECO 404	12-10-82
A	INITIAL RELEASE	12-1-82
LTR	REVISION	DATE

OBERHEIM

- PARTS LAYOUT -
 OB-8 POT BOARD #1

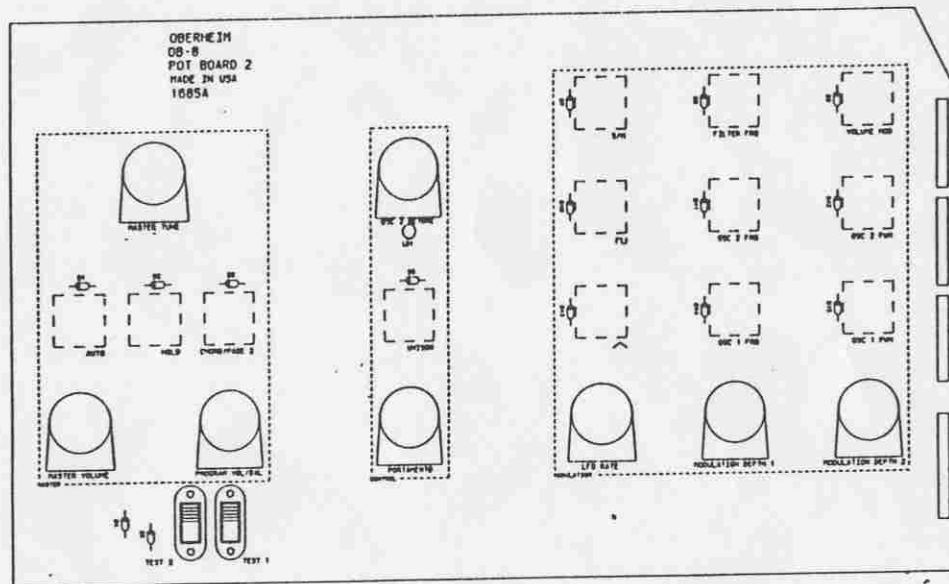

B	ECD 404	12-10-82
A	INITIAL RELEASE	12-1-82
LTR	REVISION	DATE

OBERHEIM
- PARTS LAYOUT -
OB-8 POT BOARD #2
1692 B