

 Roland

MIDI

MIDI→CV INTERFACE
MPU-101

RADIO AND TELEVISION INTERFERENCE

Warning – This equipment has been verified to comply with the limits for a Class B computing device, pursuant to Subpart J, of Part 15, of FCC rules. Operation with non-certified or non-verified equipment is likely to result in interference to radio and TV reception.”

The equipment described in this manual generates and uses radio-frequency energy. If it is not installed and used properly, that is, in strict accordance with our instructions, it may cause interference with radio and television reception.

This equipment has been tested and found to comply with the limits for a Class B computing device in accordance with the specifications in Subpart J, of Part 15, of FCC Rules. These rules are designed to provide reasonable protection against such a interference in a residential installation. However, there is no guarantee that the interference will not occur in a particular installation. If this equipment does cause interference to radio or television reception, which can be determined by turning the equipment on and off, the user is encouraged to try to correct the interference by the following measure:

- Disconnect other devices and their input/output cables one at a time. If the interference stops, it is caused by either the other device or its I/O cable.

These devices usually require Roland designated shielded I/O cables. For Roland devices, you can obtain the proper shielded cable from your dealer. For non Roland devices, contact the manufacturer or dealer for assistance.

If your equipment does cause interference to radio or television reception, you can try to correct the interference by using one or more of the following measures:

- Turn the TV or radio antenna until the interferences stops.
- Move the equipment to one side or the other of the TV or radio.
- Move the equipment farther away from the TV or radio.
- Plug the equipment into an outlet that is on a different circuit than the TV or radio. (That is, make certain the equipment and the radio or television set are on circuits controlled by different circuit breakers or fuses.)
- Consider installing a rooftop television antenna with coaxial cable lead-in between the antenna and TV.

If necessary, you should consult your dealer or an experienced radio/television technician for additional suggestions. You may find helpful the following booklet prepared by the Federal Communications Commission:

“How to Identify and Resolve Radio-TV Interference Problems”

This booklet is available from the U.S. Government Printing Office, Washington, D.C., 20402, Stock No. 004-000-00345-4.

Bescheinigung des Herstellers /Importeurs

Hiermit wird bescheinigt, daß der/die/das

MIDI – CV INTERFACE MPU-101

(Gerät, Typ, Bezeichnung)

in Übereinstimmung mit den Bestimmungen der

Vfg 1046 / 1984

(Amtsblattverfügung)

funk entstört ist.

Der Deutschen Bundespost wurde das Inverkehrbringen dieses Gerätes angezeigt und die Berechtigung zur Überprüfung der Serie auf Einhaltung der Bestimmungen eingeräumt.

Roland Corporation

Name des Herstellers/Importeurs

IMPORTANT NOTES

- The appropriate power supply for this unit is shown on its name plate. Please make sure that the voltage system in your country meets it.
- Do not turn the MPU-101 on before connecting the power cable to the wall socket.
- This unit might not work properly if turned on immediately after being turned off, if this happens, simply turn it off, and turn it on again a few seconds later.
- Before setting up the MPU-101 with an external synthesizer, be sure to turn both of them off.
- Using the MPU-101 near a neon or fluorescent lamp may cause noise interference. If so, change the angle or position of the MPU-101.
- Avoid using the MPU-101 in extreme heat or humidity or where it may be affected by dust.
- Use a soft cloth and clean only with a mild detergent.
- Do not use solvents such as paint thinner.
- Do not connect more than three MIDI devices using the MIDI THRU's. Use the MIDI THRU Box MM-4 (optional).

OUTLINE

- The MPU-101 is a MIDI-CV Interface that converts MIDI messages to analog voltages.
- Now, the MIDI messages can control the sound modules that have 1 V/oct CV input and positive gate (=high level when Note On) input or even negative gate (=low level when Note On).
- Not only Note Number but also Key Velocity, Pitch Bender, Modulation, Aftertouch and Volume messages can be converted to CVs, allowing wide variety of applications.
- The MPU-101 accepts the messages of any MIDI Channel and converts them to CVs. In the Mono mode, up to four MIDI Channels can be distributed to the separate Outputs.
- The Gate Output of the MPU-101 can be used as Trigger Pulse of percussion sound module (e.g. BOSS PC-2, HC-2), sampling machine (e.g. BOSS DSD-2), or digital delay (e.g. BOSS DE-200).
- The MPU-101 features "Special Mode" that allows to distribute highest, lowest and latest notes of a chord to three different Outputs.
- The MIDI OUT Connector allows connection of two MPU-101's, therefore setup of 5 to 8 monophonic synthesizers.
In the Special mode, any of the highest, latest, or lowest note can be distributed to this MIDI OUT.

CONTENTS

1 Panel Description	6	5 Sub Functions	34
1. Setup with a monophonic synthesizer	7	1. MIDI-Trigger Interface	34
2 Setup Examples (Basic)	7	2. Inverted Gate Logic	36
1. Setup with two monophonic synthesizers	8	6 Received Data—Output Voltage Table	37
2. Setup with three monophonic synthesizers	10	1. Note Number and CV Output	37
3. Setup with four monophonic synthesizers	12	2. Modulation, Aftertouch and Volume	38
4. Setup in Special mode	14	3. Pitch Bender	38
3 Functions	15	Specifications	39
4 Setup Examples (Advanced)	23		
1. Using Dynamics Output	23		
2. Using Bender Output	24		
3. Using Modulation Output	25		
4. Using Aftertouch Output	25		
5. Using Volume Output	26		
6. Controlling Portamento	27		
7. Applications of Gate Output	28		
8. Using two MPU-101's	30		

Please read the separate book "MIDI" before this owner's manual.

3 PANEL DESCRIPTION

Rear Panel

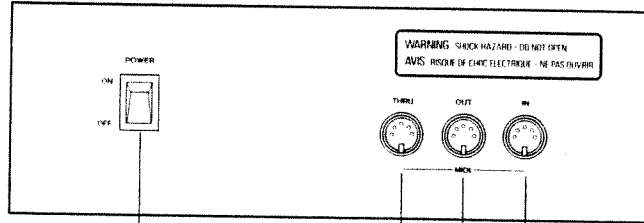

1 Power Switch

2 MIDI THRU Connector

3 MIDI OUT Connector

4 MIDI IN Connector

Front Panel

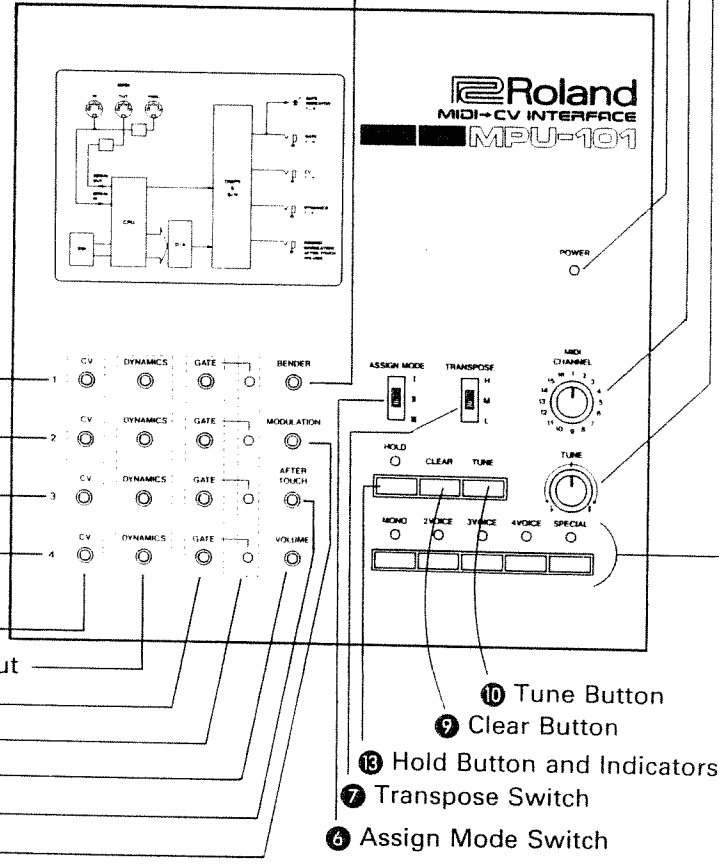

Output 1

Output 2

Output 3

Output 4

21 CV Output

20 Dynamics Output

19 Gate Output

18 Gate Indicator

17 Volume Output

16 Aftertouch Output

15 Modulation Output

14 Bender Output

11 Tune Knob

8 MIDI Channel Switch

5 Power Indicator

Roland
MIDI-CV INTERFACE
MPU-101

POWER

10 Tune Button

9 Clear Button

13 Hold Button and Indicators

7 Transpose Switch

6 Assign Mode Switch

12 Operation Mode Button and Indicators

2 SETUP EXAMPLES (Basic)

1. Setup with a monophonic synthesizer

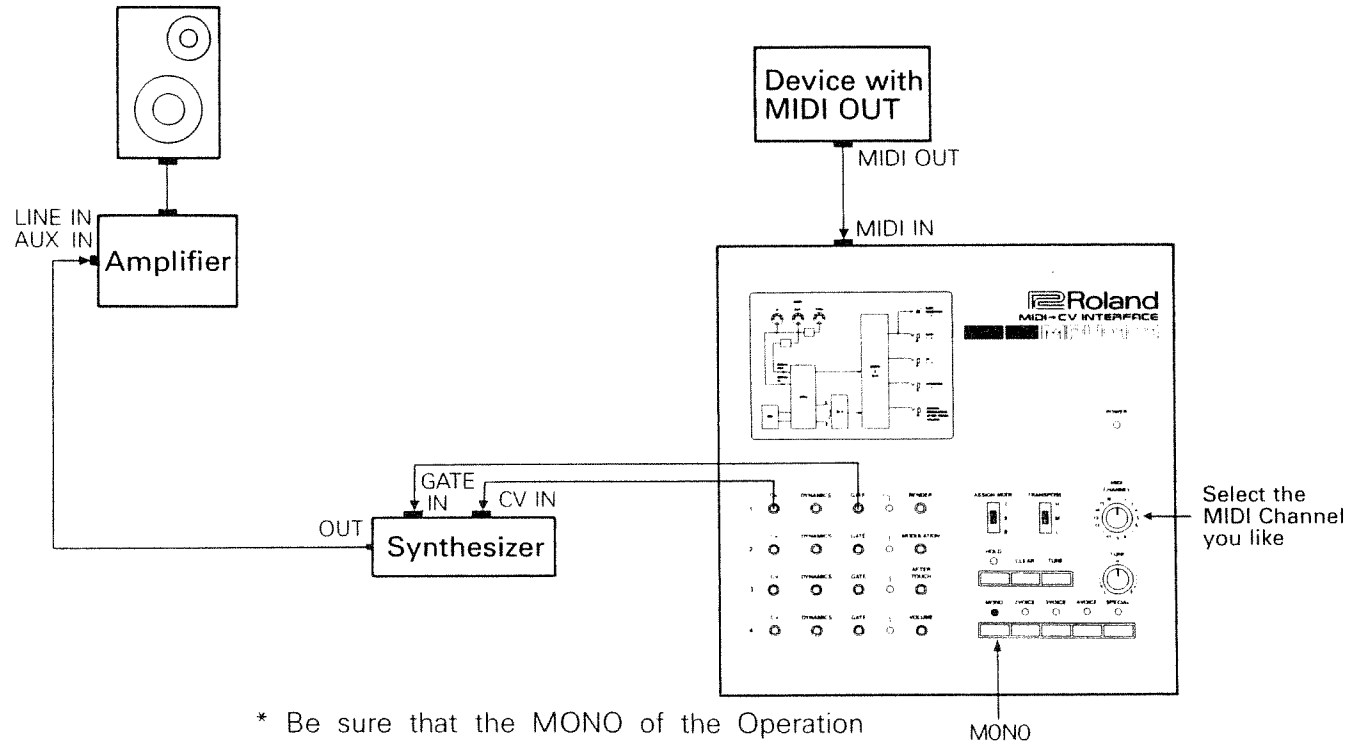

- * Be sure that the MONO of the Operation Buttons is turned on.
- * When a data of a chord is received, the last note (the Note On received latest) will be distributed to the Output 1.

2. Setup with two monophonic synths

(a) When the Operation mode MONO is selected:

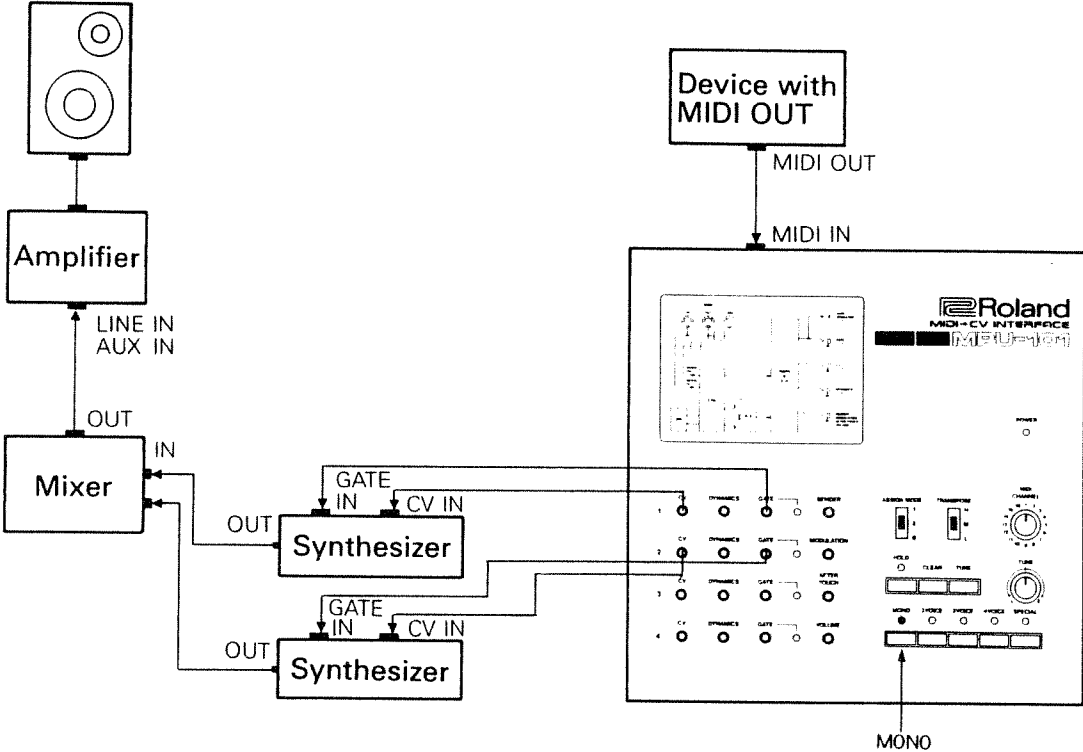

* The message of the MIDI Channel selected with the MIDI Channel Switch will be assigned to the Output 1, and that plus 1 channel to the Output 2.

(b) When the 2 VOICE mode is selected:

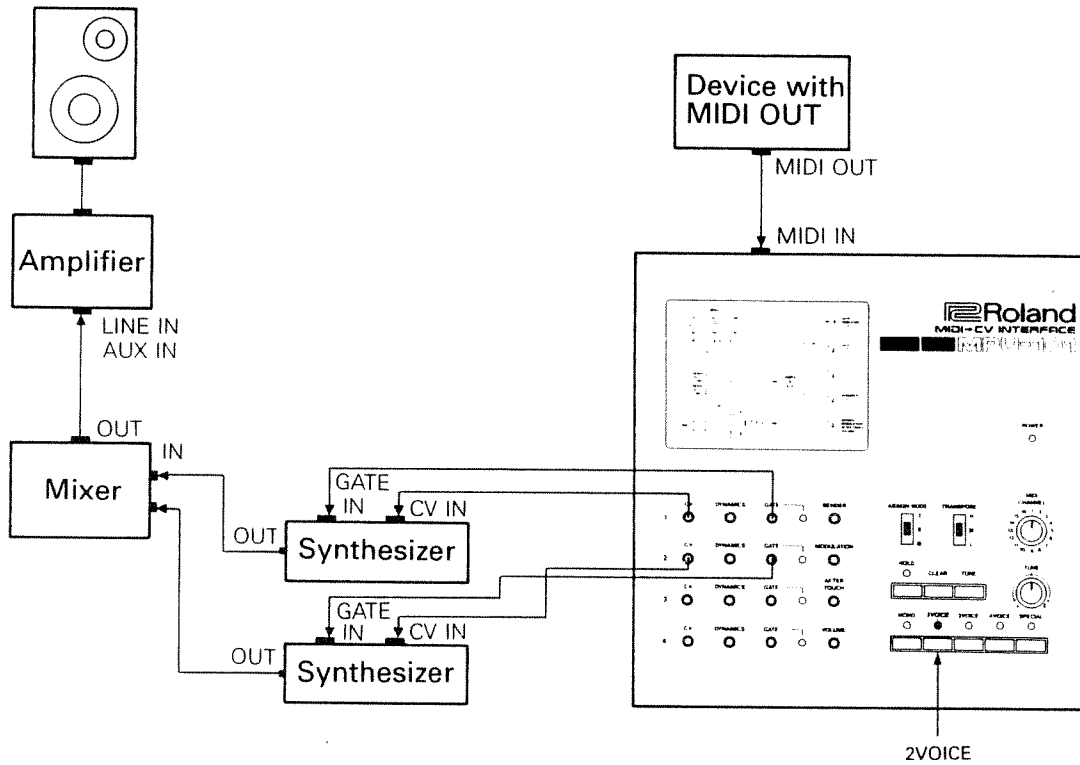

* The first two notes of a chord will be respectively assigned to the Output 1 and 2. The Assign Mode Switch determines how the notes are assigned.

3. Setup with three monophonic synthesizers

(a) When the Operation mode MONO is selected:

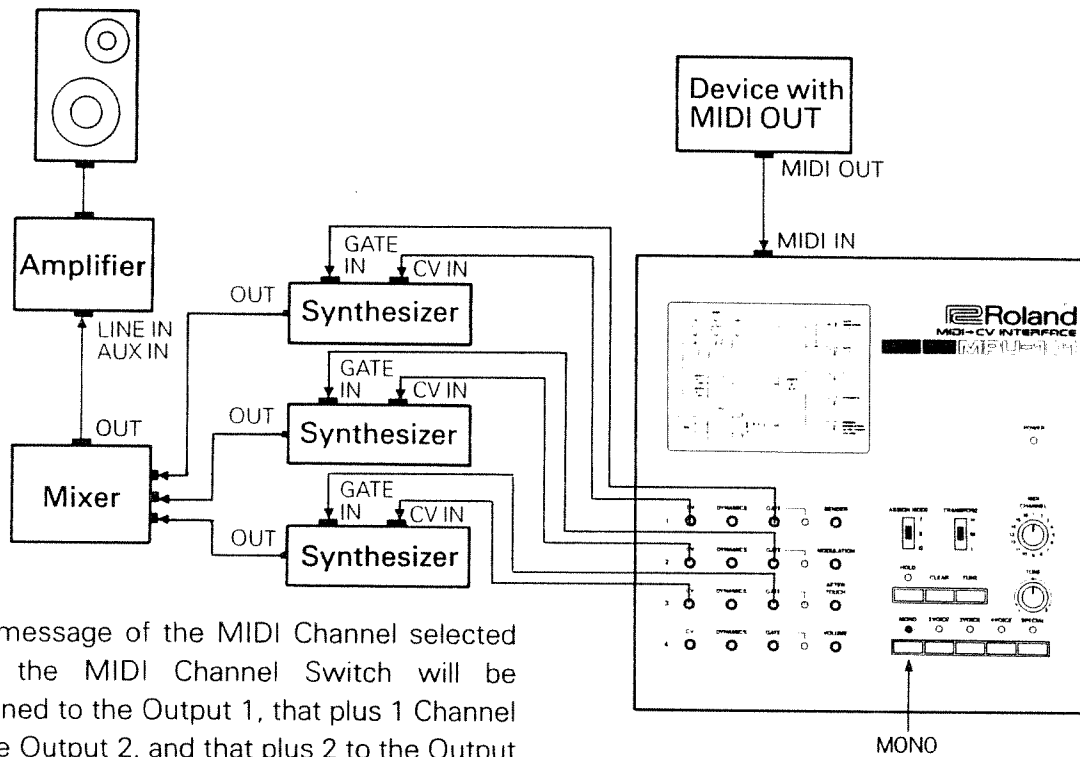

* The message of the MIDI Channel selected with the MIDI Channel Switch will be assigned to the Output 1, that plus 1 Channel to the Output 2, and that plus 2 to the Output 3. For example, if the MIDI Channel Switch is set to the 2 position, the message of channel 2 is assigned to the Output 1, channel 3 to Output 2 and the channel 4 to Output 3.

(b) When the 3 VOICE mode is selected:

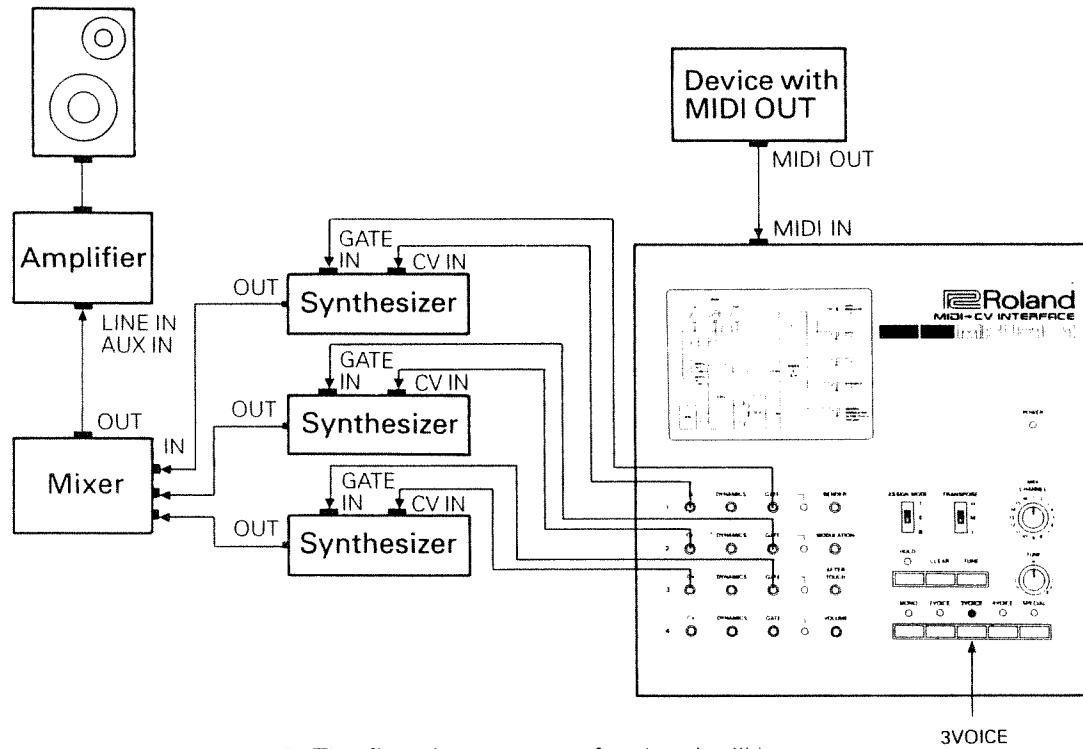

* The first three notes of a chord will be respectively assigned to the Outputs 1 to 3. The Assign Mode Switch decides how these notes are assigned.

4. Setup with four monophonic synthesizers

(a) When the Operation mode MONO is selected:

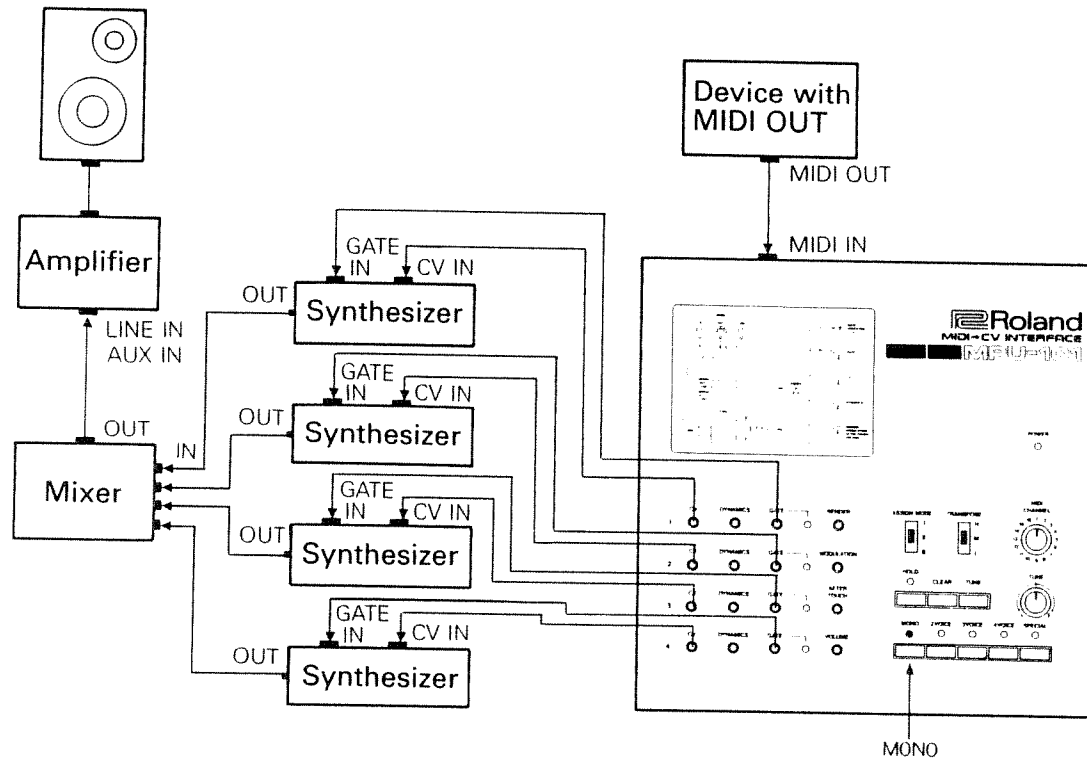

* The message of the channel number set with the MIDI Channel Switch is assigned to the Output 1, the follower Channels are subsequently assigned to the Output 2, 3 and 4.

(b) When the Operation mode 4 VOICE is selected:

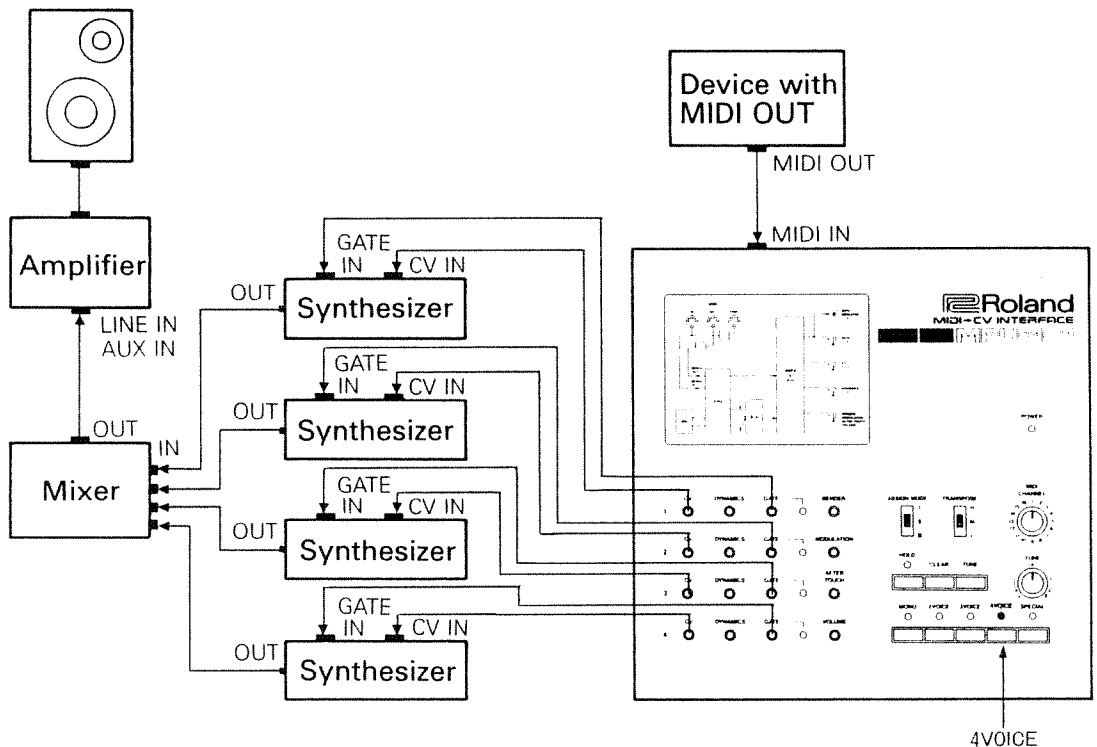

* The first four notes of the chord data (on the channel set with the MIDI Channel Switch) will be respectively assigned to the Output 1 to 4. The Assign Mode Switch determines how these notes are to be assigned.

5. Setup in Special Mode

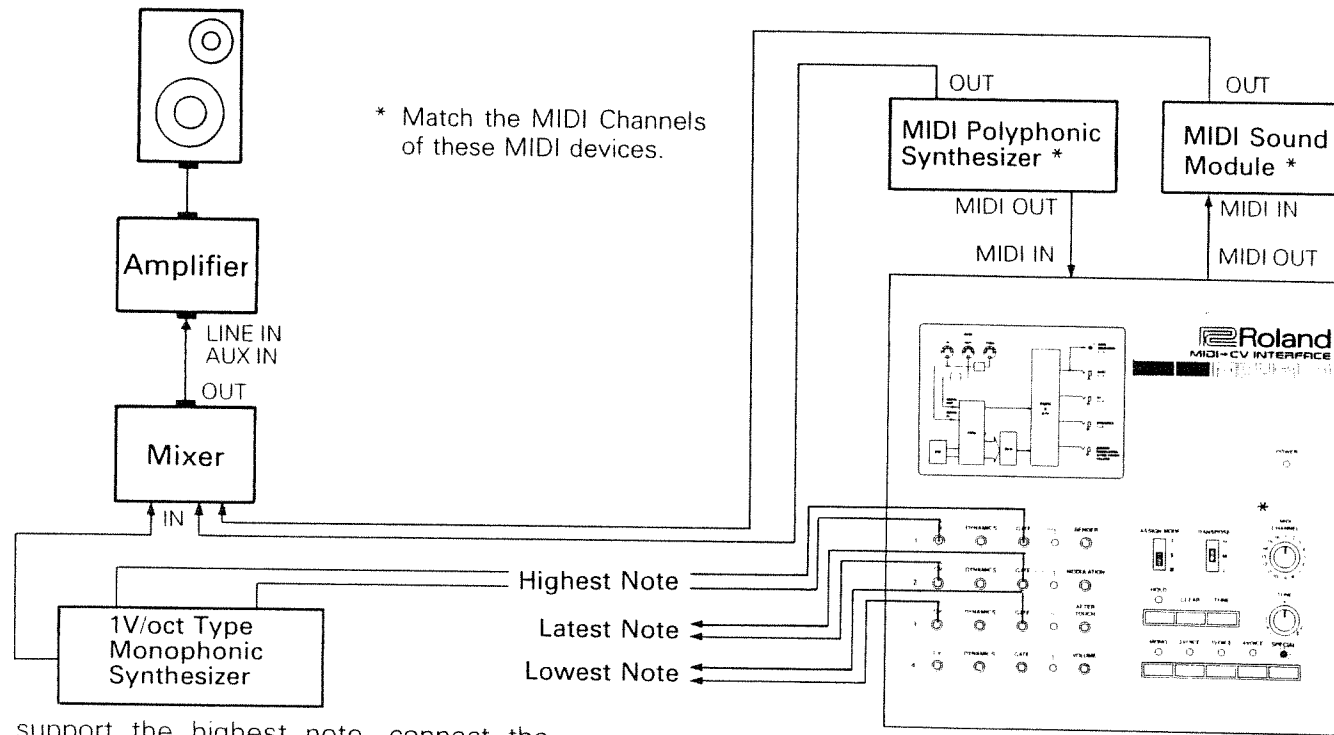

To support the highest note, connect the monophonic synthesizer to the Output 1, to support the latest note, to the Output 2, and to support the lowest note, to the Output 3. When the Output 4 is used, the note selected at the Assign Mode Switch will be supported. Also, the MIDI OUT sends out the note number distributed to the Output 4.

In above setup, the monophonic synthesizer supports the highest note of the chord played on the polyphonic synthesizer, while another MIDI Sound Module supports the lowest note.

3 FUNCTIONS

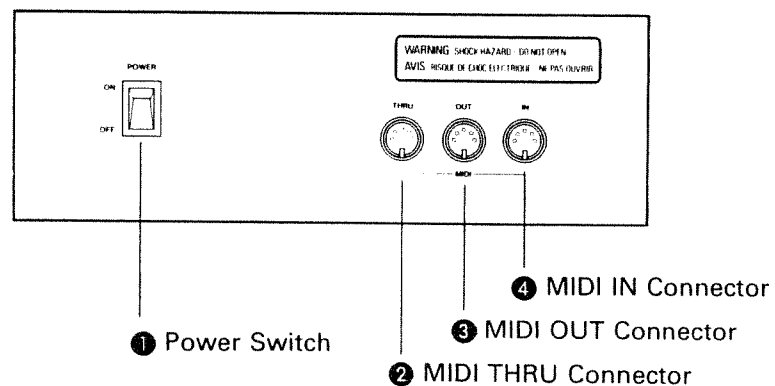

1 Power Switch

2 MIDI THRU Connector

Exact copy of the signal fed into the MIDI IN will be sent from this socket.

3 MIDI OUT Connector

From this socket, the overflowed messages in the Poly mode, or the Note On/Off message in the Special mode are sent out. (See "Operation Mode Buttons" on page 19.)

4 MIDI IN Connector

MIDI messages are fed into the MPU-101 from this socket.

5 Power Indicator

This lights up when the MPU-101 is turned on.

6 Assign Mode Switch

When the Operation Mode is set to Poly (2 VOICE, 3 VOICE, or 4 VOICE), the Assign Mode Switch selects how the Note On messages are to be assigned to each Output.

I Non-Rotary Mode

When legato manner is taken or a chord is played, the Note On messages will be succeedingly assigned to Output 1 to n (where n is the voice number). For example in 4 voices, 1 → 2 → 3 → 4. The first Note On message, however, will be assigned to the Output 1.

II Rotary Mode A

The Note On messages will be succeedingly assigned to the Outputs 1 to n (where n is the voice number). If any of the Outputs has a note of the same pitch, the note will be assigned to that Output.

III Rotary Mode B

The Note On messages will be succeedingly assigned to Outputs 1 to n (where n is the voice number).

ASSIGN MODE



* Assign Mode Switch in Special Mode

When the MPU-101 is set to the Special mode, the Assign Mode Switch will serve to select which one of the highest, latest or lowest note is to be sent out from the MIDI OUT and Output 4.

7 Transpose Switch

This switch is used to simultaneously transpose all the four CV Outputs up or down by one octave. Refer to the table on page 37.

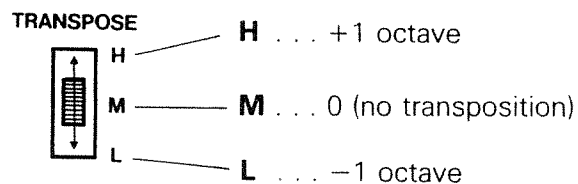

8 MIDI Channel Switch



This selects recognized MIDI Channel(s).

(In Mono Mode)

- Select a MIDI Channel which is to be assigned to the Output 1. This automatically assigns the MIDI Channel one number higher than that to the Output 2. Likewise, the MIDI Channel two higher than the selected MIDI Channel will be assigned to the Output 3, and so on. If, however, the MIDI Channel greater than 13 is selected, the number greater than 16 will be ignored.

e.g.)

- When MIDI Channel 3 is selected

Output 1 . . . MIDI Channel 3

Output 2 . . . MIDI Channel 4

Output 3 . . . MIDI Channel 5

Output 4 . . . MIDI Channel 6

- When MIDI Channel 15 is selected

Output 1 . . . Channel 15

Output 2 . . . Channel 16

There is no output from the Output 3 and 4.

(In Poly or Special Mode)

- Select MIDI Channel number you like to receive.

MIDI Mode Message

The MPU-101 does not recognize any MID Mode messages. That is, the OMNI Mode OFF is always selected, and Poly or Mono mode can be selected only by panel operation. (See page 19.)

9 Clear Button

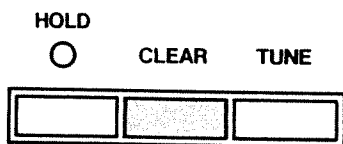

Pushing this button will turn the Gate Outputs off, and set the Pitch Bender, Modulation, Aftertouch and the Volume to the default values (Volume: 5V, Others: 0V).

10 Tune Button

11 Tune Knob

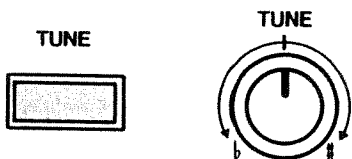

This Tune Knob works on all the four Outputs simultaneously, therefore is useful for final tuning. The variable range is approximately ± 100 cent.

* Tuning

[Operation]

- ① Set the Tune Knob to the center position.
- ② Push the Tune Button.

Now, 2.75V is sent from each of the four CV Outputs, and all the four Gate Outputs are turned on.

- ③ Tune the sound modules to A4 (442Hz).

Using a tuning unit such as the BOSS TU-12 will allow more accurate tuning.

- ④ Push the Tune Button.
Now, the tuning mode is cancelled.

* To tune to the pitch other than A=442Hz, rotate the Tune Knob.

12 Operation Mode Buttons and Indicators

a. Mono Mode

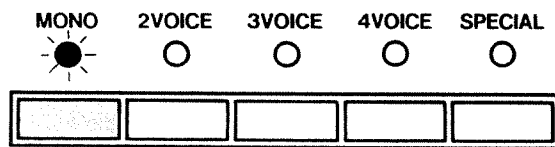

In this mode, the MPU-101 recognizes the selected MIDI Channel and three more channels (of the number plus 1, 2, and 3), then respectively distribute them to the four Outputs.

- * This mode enables several monophonic synthesizers to play different parts.
- * If a chord is transmitted in one Channel, the CV Output of the Channel will be updated with the latest Note On message.

b. Poly Mode (2 VOICE, 3 VOICE, 4 VOICE)

In this mode, the MPU-101 recognizes Note On/Off messages in the selected MIDI Channel, and assigns them as shown below.

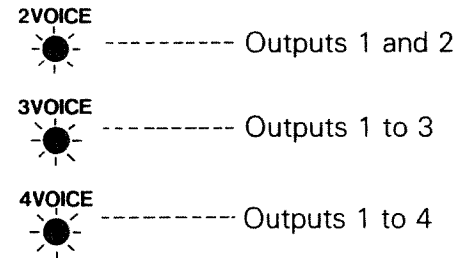
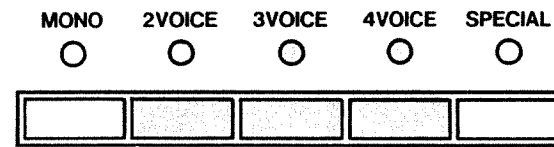

- * If the number of Note On messages (chord number) received by the MPU-101 exceeds the number of Voices you set, messages which are not assigned to the Outputs will be sent out (overflowed) from the MIDI OUT. Therefore, by setting up two MPU-101's, up to 8 voice outputs are possible. (See page 30.)
- * The Assign Mode Switch determines how the voices are assigned to the 4 Outputs. (See page 20.)

c. Special Mode

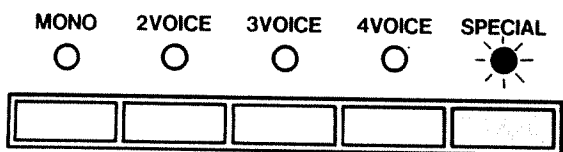

In this mode, the highest, latest and lowest notes of the MIDI messages (a chord) in the selected MIDI Channel are respectively assigned to the Outputs 1, 2 and 3. Any of the highest, latest or lowest note can be assigned to the Output 4. The note assigned to the Output 4 is also sent out from the MIDI OUT.

Selecting a note to be assigned to the Output 4 (and MIDI OUT)

Use the Assign Mode Switch to select the note to be assigned to the Output 4 and MIDI OUT.

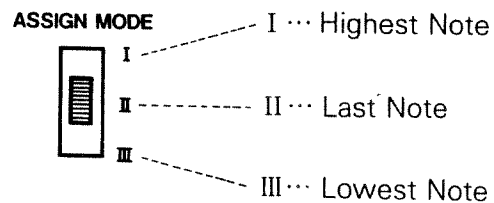

■ Special Assign of the Lowest Note

You may want the MPU-101 to reject the lowest note that is much higher than the note received just before. For example, if you have been playing chord and melody using the lowest note as bass, then play only the melody next moment, the lowest note of the melody part will be automatically detected as the lowest note. This will be extremely inconvenient for you.

There are three kinds of Special Assign Modes in the MPU-101 to resolve this problem as shown below. **To turn the MPU-101 to the Special Assign Mode, simultaneously push the SPECIAL Button , and one of the 2 VOICE, 3 VOICE, 4 VOICE or MONO button.**

(a) SPECIAL + 2VOICE

The lowest note is ignored, if it is higher than the previous note by more than an octave.

(b) SPECIAL + 3VOICE

The lowest note is ignored, if it is higher than the previous note by more than an octave and fifth.

(c) SPECIAL + 4VOICE

The lowest note is ignored, if it is higher than the previous note by more than two octaves.

(d) SPECIAL + MONO

The lowest note is ignored, if it is higher than the middle C. Also, in this mode, the highest note is ignored if it is lower than the middle C.

13 Hold Button and Indicator

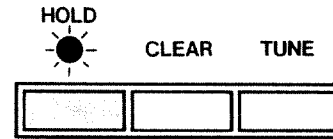

This button selects whether to recognize or ignore the Hold message transmitted from the MIDI device. When the Hold Indicator is lighted, the message will be recognized.

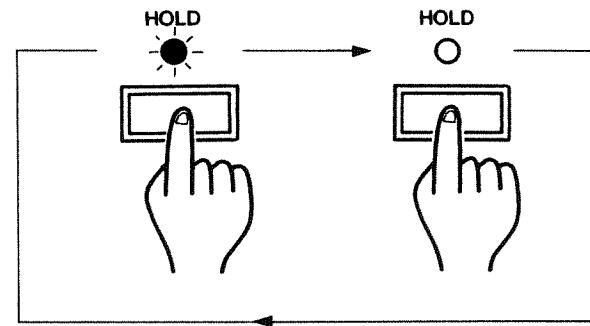

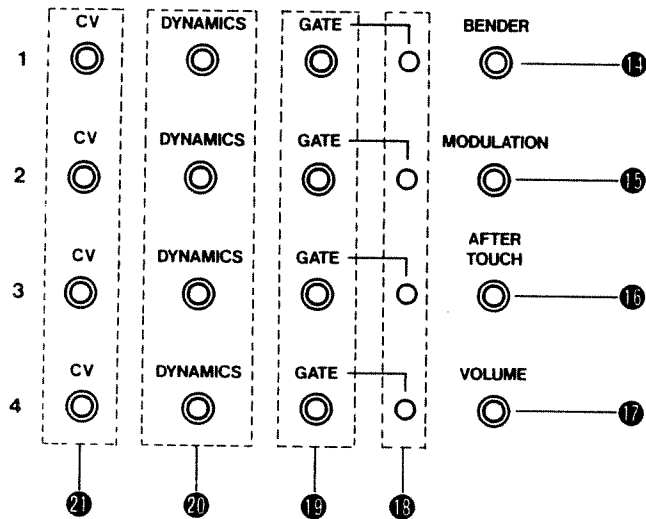

14 Pitch Bender Output Jack

From this jack, the latest Pitch Bender message in the selected MIDI Channel is converted to CV and sent out.

15 Modulation Output Jack

From this jack, the latest Modulation message in the selected MIDI Channel is converted to CV and sent out. (Control Change #1 is used.)

16 Aftertouch Output Jack

From this jack, the latest Aftertouch messages in the selected MIDI Channel is converted to CV and sent out.

17 Volume Output Jack

From this jack, the latest Volume message in the selected MIDI Channel is converted to CV and sent out. (Control Change #7 is used.)

18 Gate Indicators

These are lighted while the Gates are ON. When the Inverted Gate mode is selected with the Sub Function, the indicators are dark when the Gates are ON.

19 Gate Output Jacks

The Note On/Off messages are converted to CVs (usually high level when Note On, and low level when Note Off), and sent out from these jacks. But this Polarity can be inverted using the Sub Function. (See page 36.)

20 Dynamics Output Jacks

Values of Key Velocity in the Note On messages are converted to CVs and sent out from these jacks.

21 CV Output Jacks

Note numbers of the Note On/Off messages are converted to pitch CVs and sent out from these jacks.

4 SETUP EXAMPLES (Advanced)

1. Using Dynamics Output

(a) Using VCA specifically for Dynamics effect

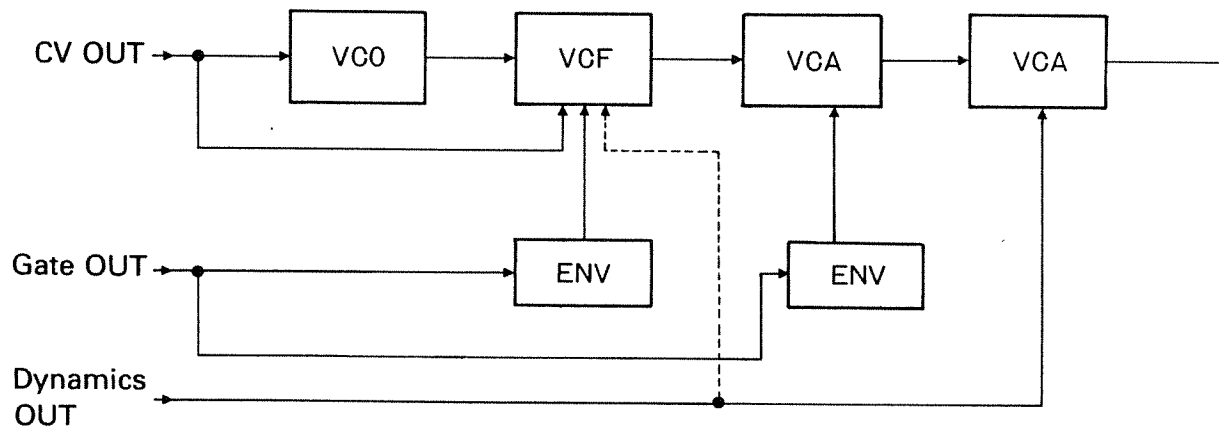
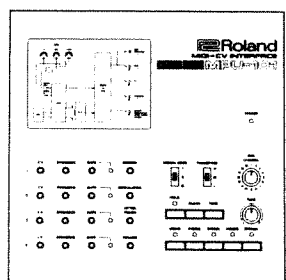

(b) Controlling the mixing balance of 2 VCO's with Dynamics

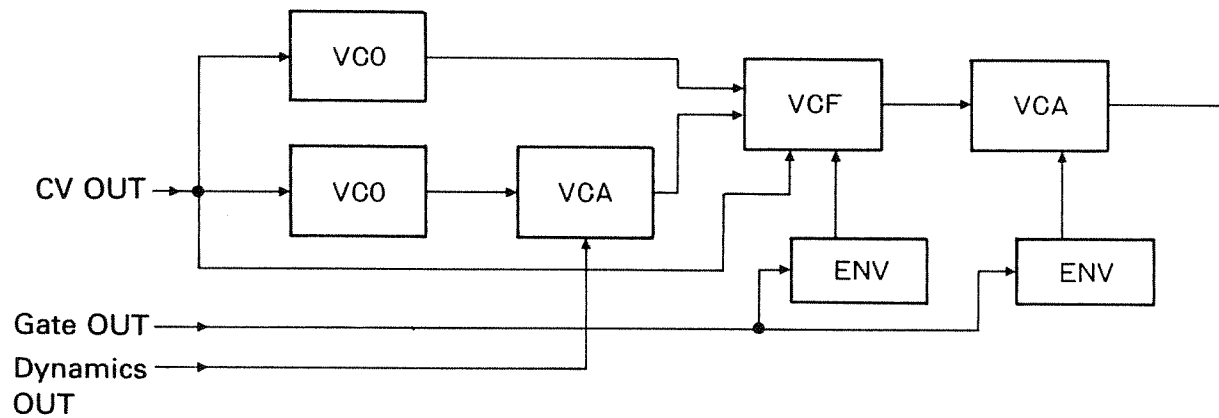
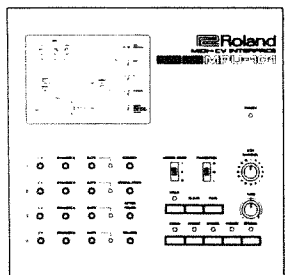

(c) Controlling the amount of the envelope voltage sent to VCF with the Dynamics

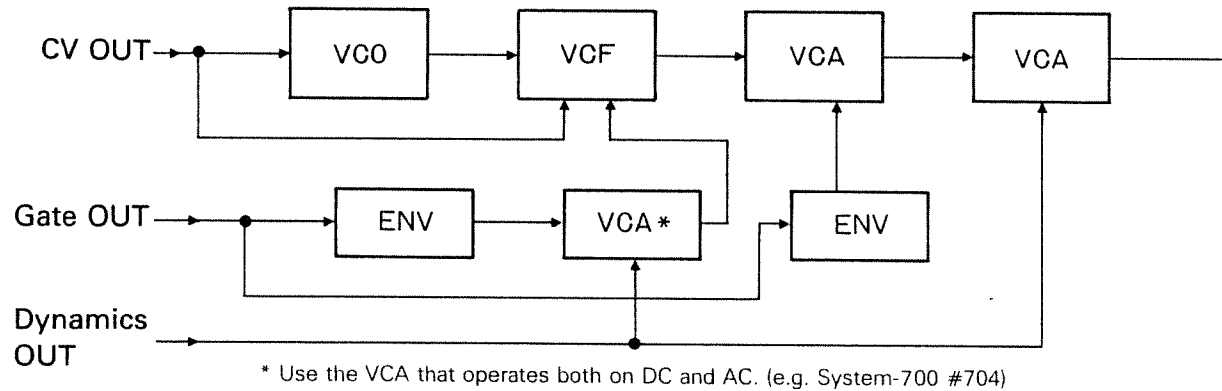
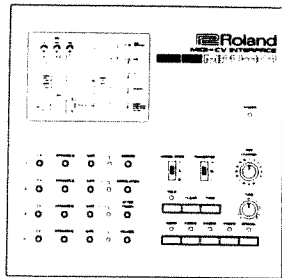

2. Using Bender Output

Controlling Pitch Bend

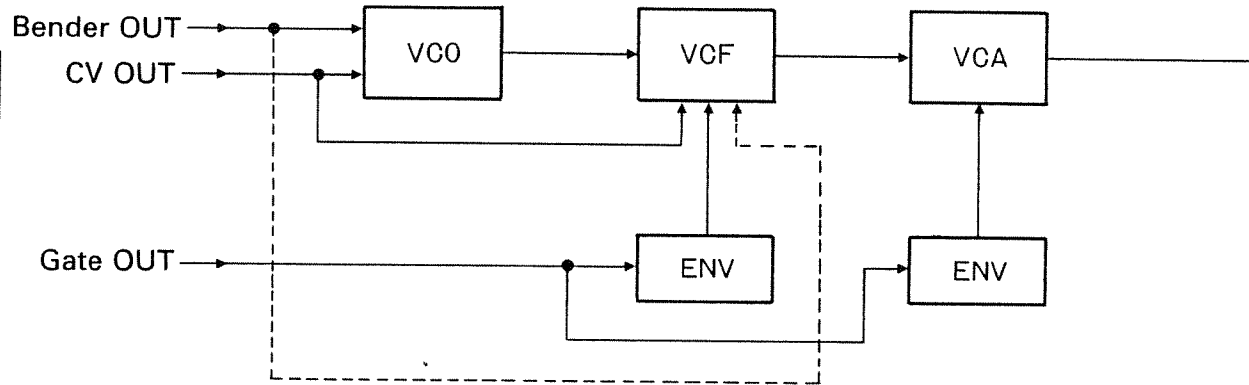
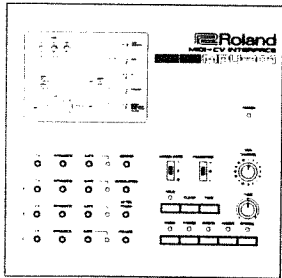

3. Using Modulation Output

Feeding LFO modulation signal to VCO

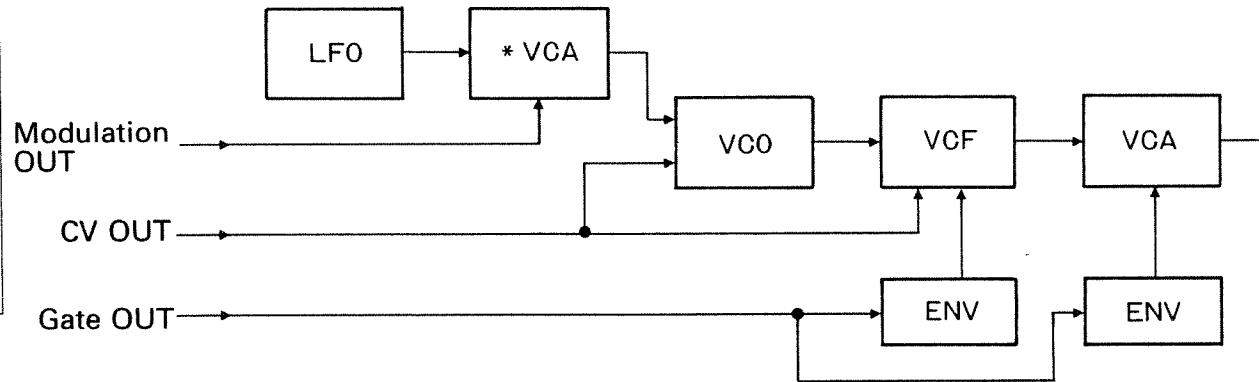
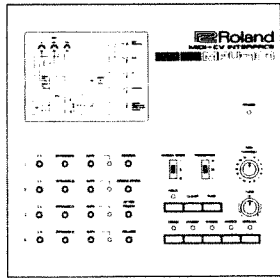

* Preferably, use the VCA that operates both on DC and AC, such as the System-700 #704. But the System-100M#130 will do to obtain usual vibrato effect.

4. Using Aftertouch Output

Controlling the VCF cutoff frequency/VCA level

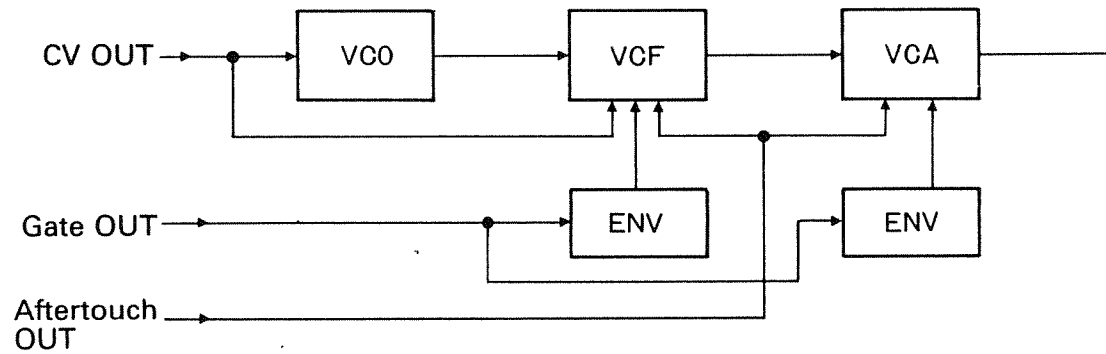
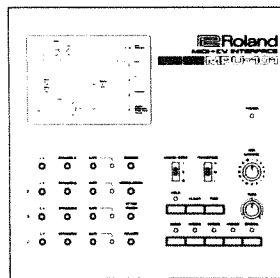

5. Using the Volume Output

Controlling the total output of the four synthesizers

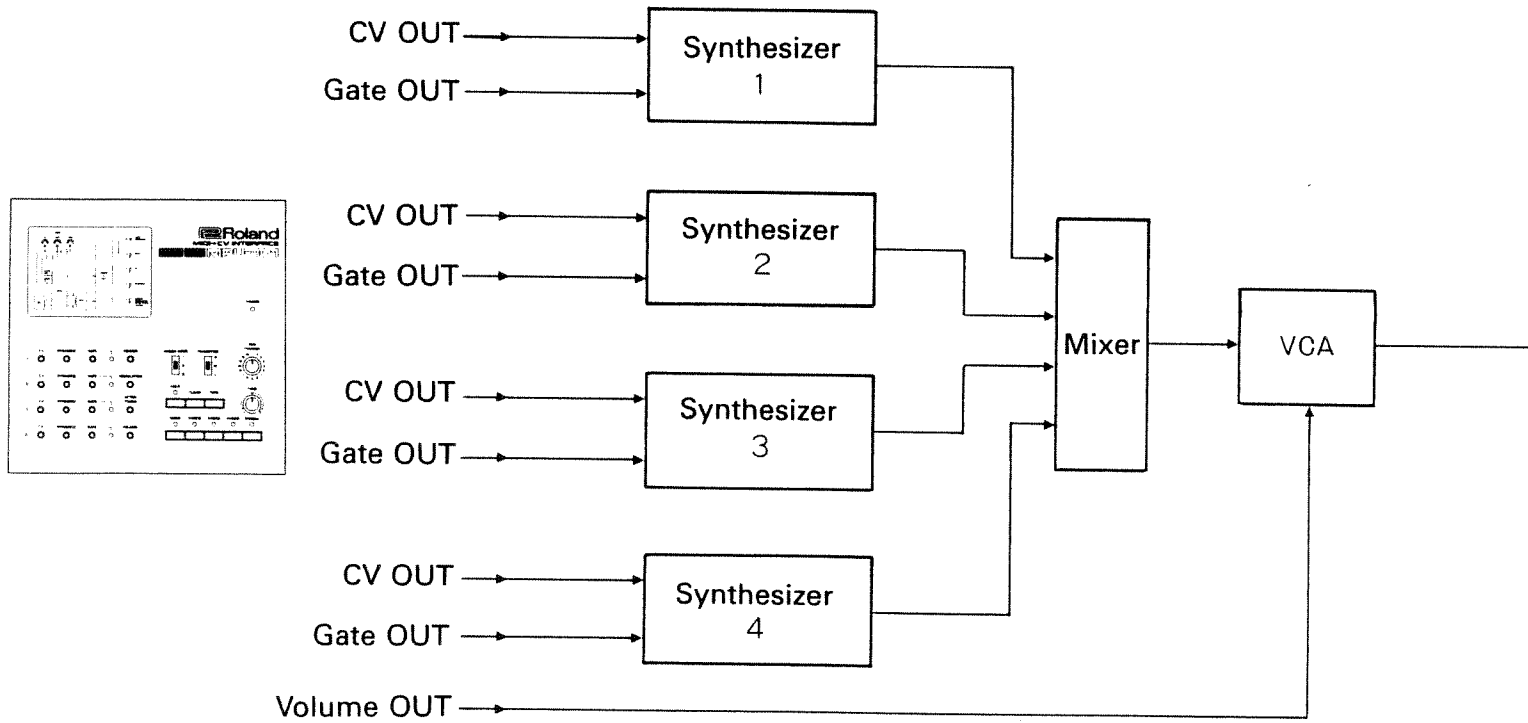

6. Controlling Portamento

The MPU-101 has no CV output for portamento, but using the, Modulation, Aftertouch and Volume Outputs, portamento effect can be changed by the amount of each voltage.

* Use the System-100M #165.

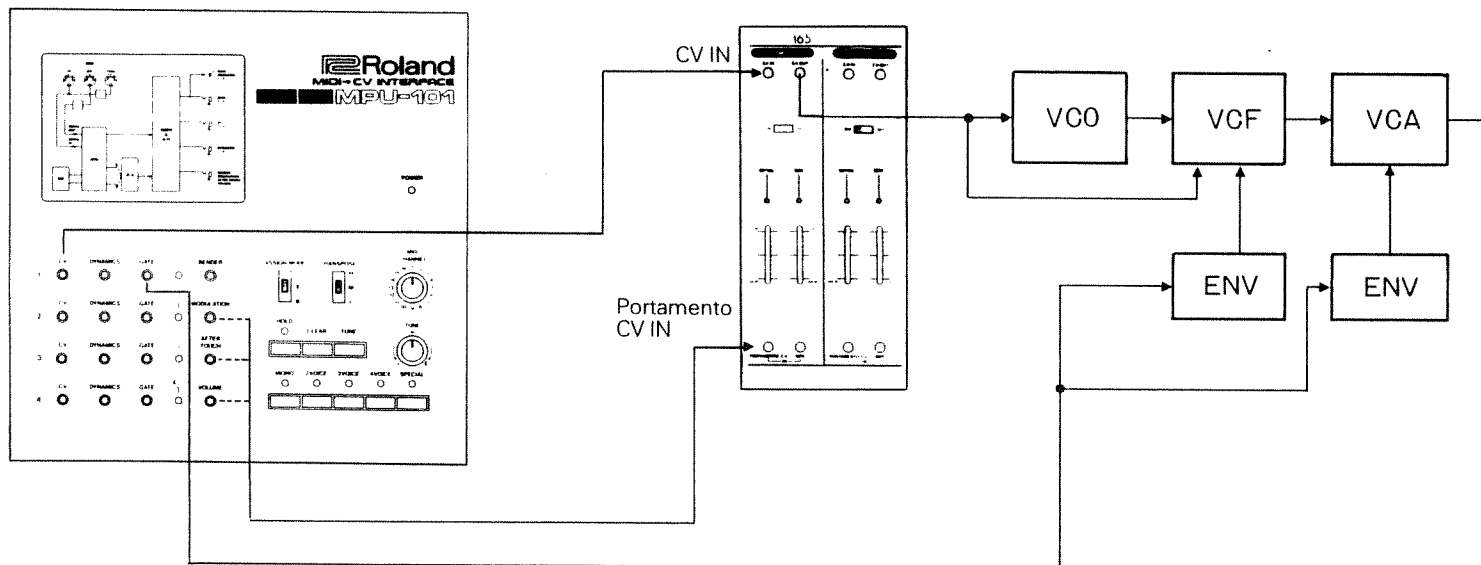

7. Applications of Gate Output

(a) Driving Percussion Sound Module or Sampling Machine with MIDI

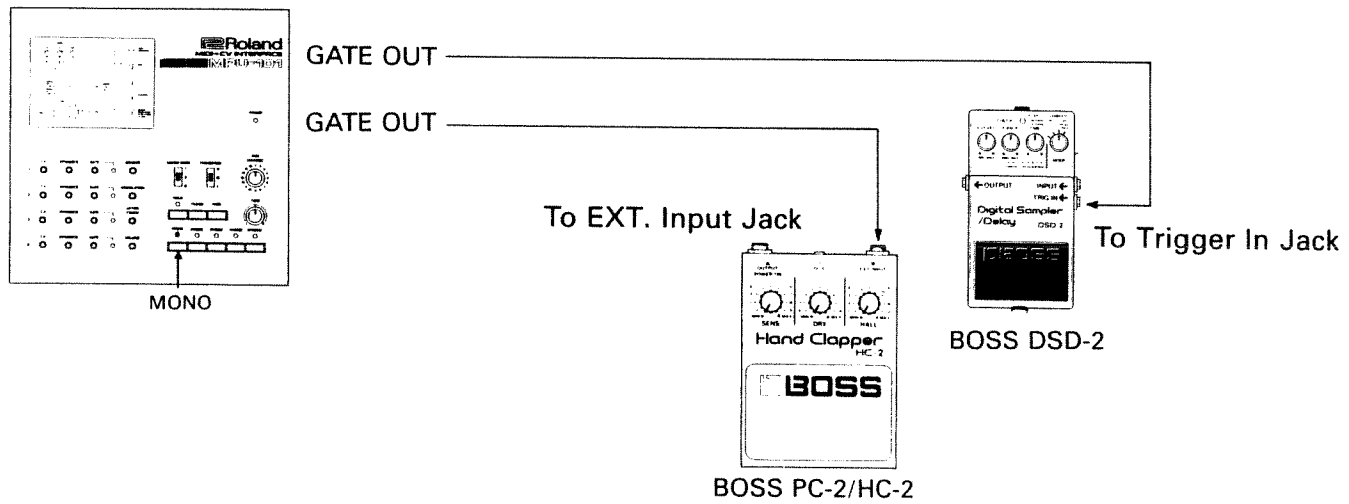

(b) Using Gate Output as On/Off switch of Effect

1) Controlling On/Off of Chorus with MIDI

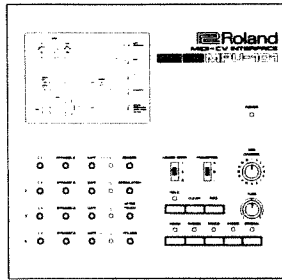

GATE OUT

To Effect Remote Jack



BOSS CE-300

2) Controlling Preset Patch of Digital Delay with MIDI

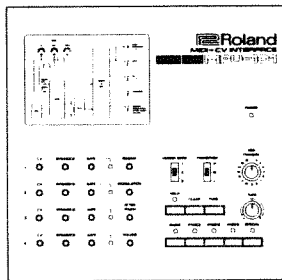

GATE OUT

To Preset Shift Jack

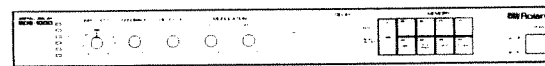

Roland SDE-1000
SDE-3000

* In above setups 1) and 2), some devices may not operate properly. (Refer to the owner's manual of each device.)

8. Using 2 MPU-101's

Setup with 8 monophonic synthesizers

The use of two MPU-101's allows more variations of MIDI Channels and Operation modes, as described on the following pages.

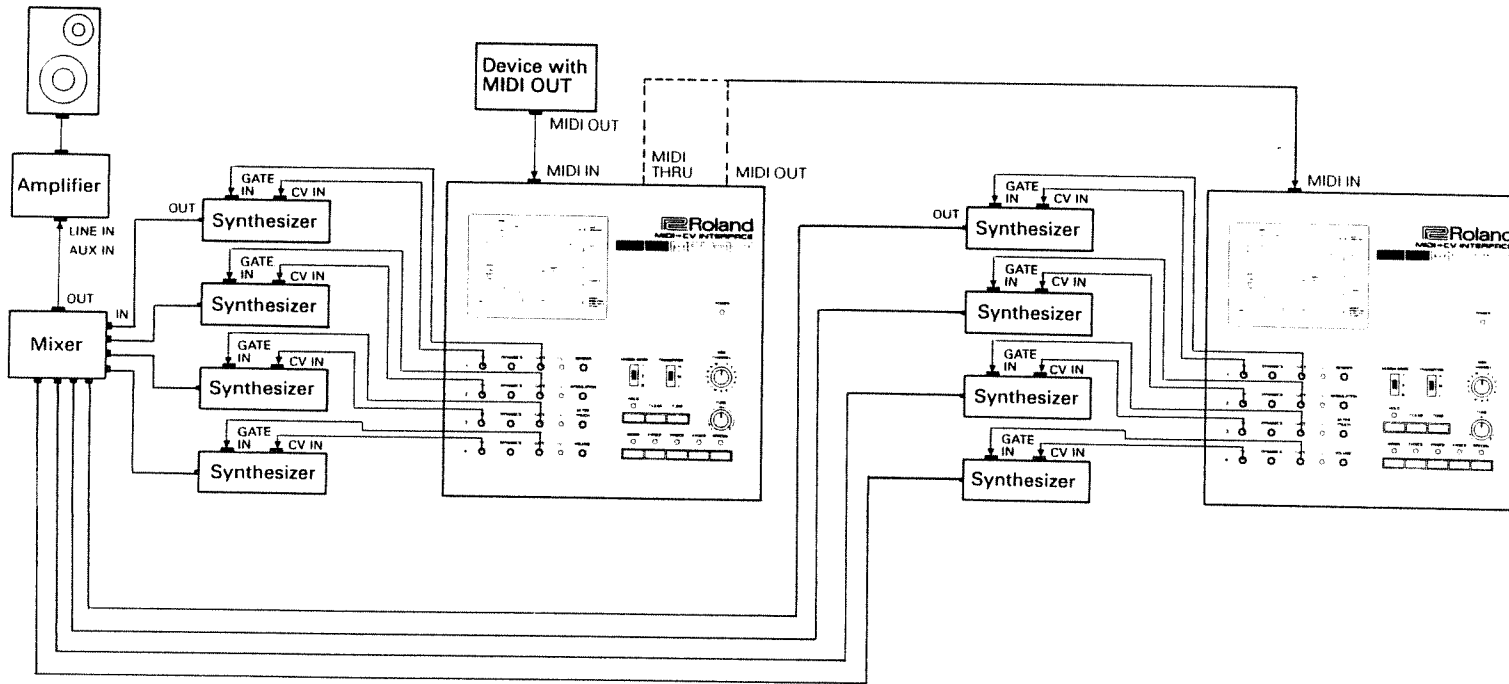

(a) With both MPU-101's set to MONO mode

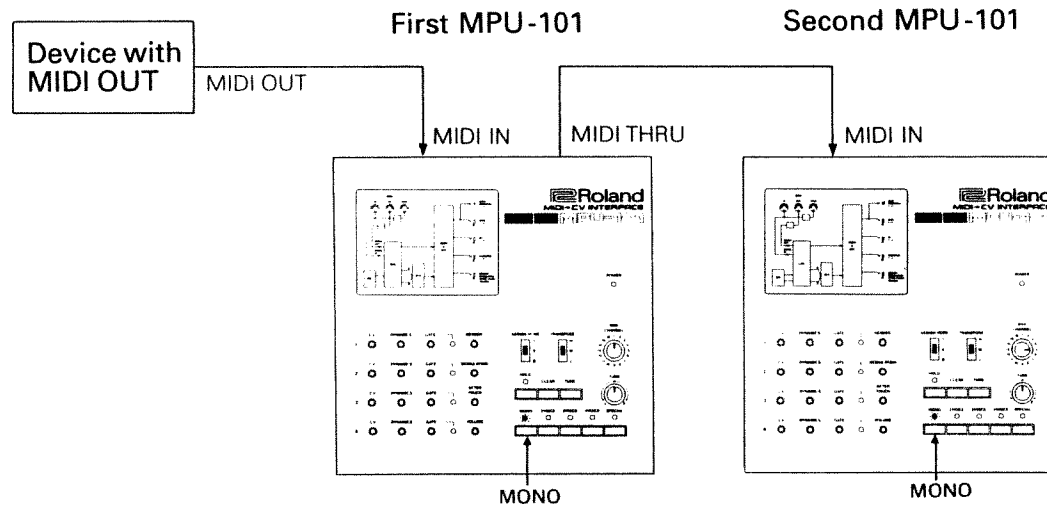

For example, set the MIDI Channel of the first MPU-101 to 1 and the second one to 5. The messages of MIDI Channels 1 to 8 will be sent out from the 1 to 4 Outputs of the both first and second MPU's.

(b) With the first MPU-101 set to POLY (4 Voice), and the second to MONO

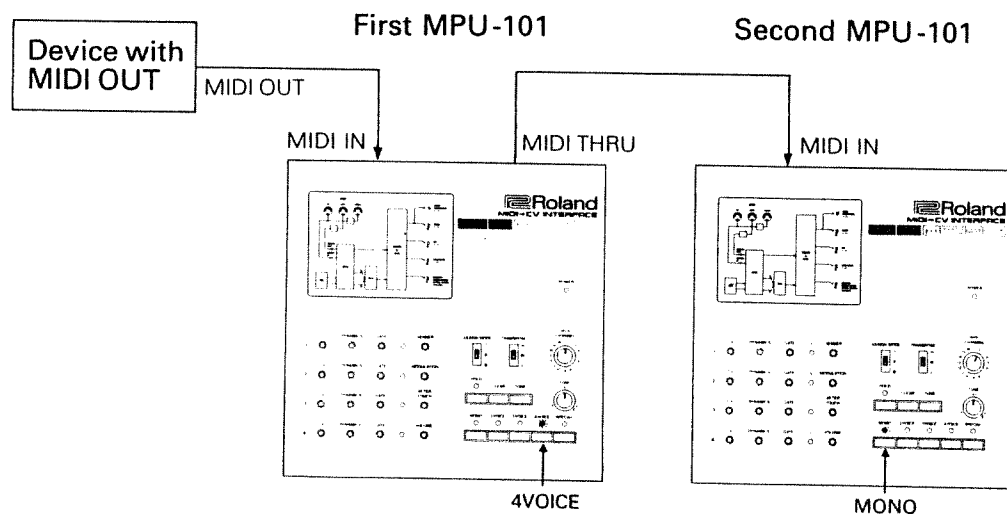

The first MPU-101 plays a chord of four notes, and the second one independently plays a single note of a different MIDI Channel.

(c) With both MPU-101's set to POLY (4 Voice)

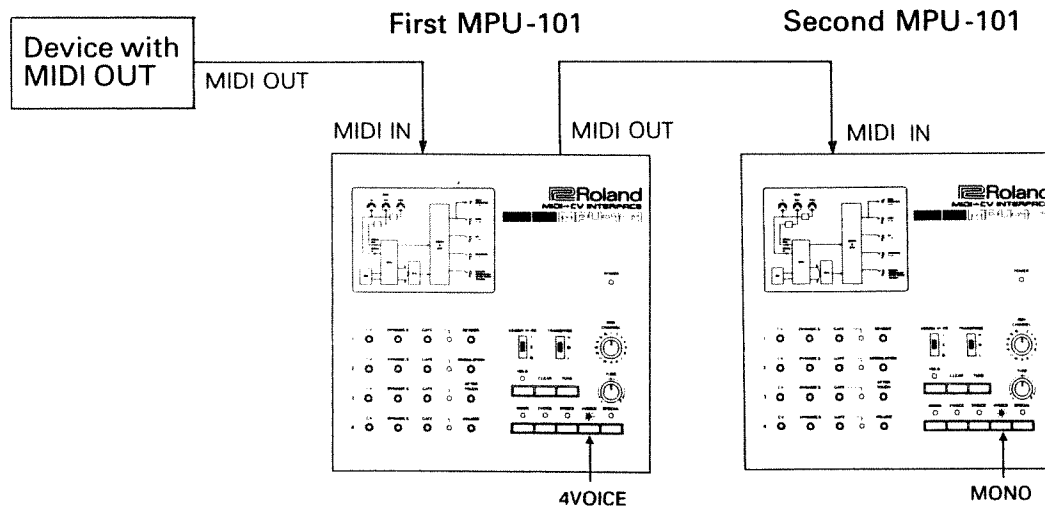

This setup makes an 8 voice synthesizer from 8 sets of monophonic synthesizers. In this setup, both MPU-101's should be set to the same MIDI Channel. Note that the MIDI OUT of the first MPU is connected to the MIDI IN of the second one.

5 SUB FUNCTIONS

1. MIDI-Trigger Interface

The MIDI-Trigger Interface mode enables you to synchronize an analog sequencer with a MIDI sequencer. Received MIDI Real Time message is changed to Trigger pulse then sent out from the Gate Outputs in the timing of sixteenth note, triplet, eighth note and quarter note.

To turn the MPU-101 to the MIDI-Trigger Interface mode, take the following operation.

- ① Turn the MPU-101 off.
- ② Turn the MPU-101 on while holding the Tune Button down.

The trigger pulse is assigned to each Gate Output as shown below. Use the one you like.

Output 1 16th Note

Output 2 Triplet

Output 3 Eighth Note

Output 4 Quarter Note

- ③ To cancel the MIDI-Trigger Interface mode, turn the unit off, then turn it on again.

Synchronizing an analog sequencer with a MIDI sequencer

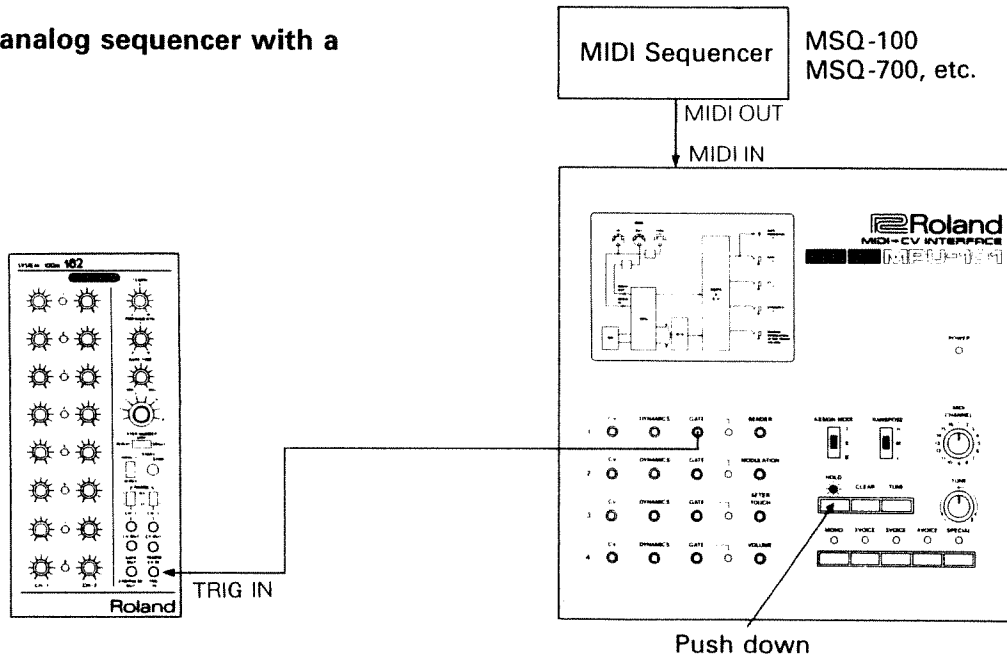

Now, the MPU-101 is in the MIDI-Trigger Interface mode. Use the Hold Button to invert the logic of the trigger pulse.

When the Hold Indicator is turned on

... Positive Gate

When the Hold Indicator is turned off

... Negative Gate

- * When the MPU-101 is turned to this MIDI-Trigger Interface mode, it does not work as a MIDI-CV interface.
- * The trigger pulse is sent out from each Gate Output when the Start or Continue message is received until the Stop message is received.

2. Inverted Gate Logic

If using the synthesizer featuring negative Gate In, you may need to invert the MPU-101's gate output.

To invert Gate Outputs, take the following operation.

- ① Turn the MPU-101 off.
- ② Push the Clear Button while turning the MPU-101 on. Now, the MPU-101 has negative pulse gate.
- ③ To cancel this mode, simply turn the unit off, then turn it on again.

6 Received Data ↔ Output Voltage

1. Note Number vs CV Output

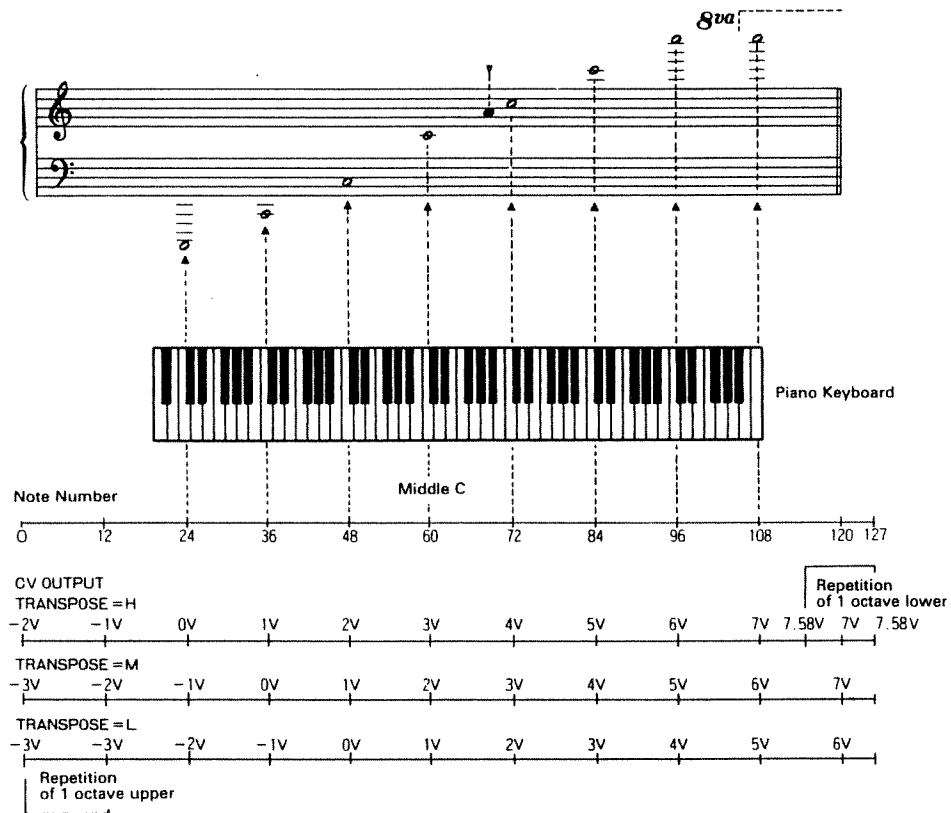

2. Modulation, Aftertouch and Volume



Adjust the maximum effect by controlling the synthesizer.

3. Pitch Bender

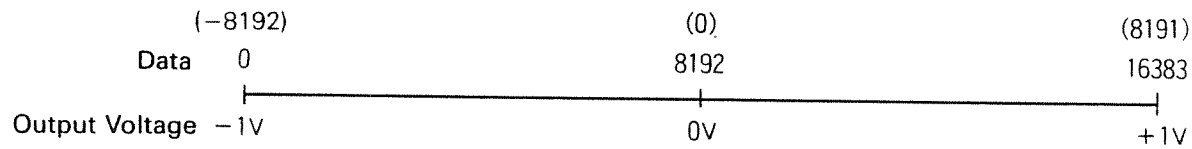

The Pitch Bender Output is 8 bit resolution. Therefore, 6 bits from the LSB of the 14 bit data transmitted do not affect the output voltage. The number in () shows the value of the input data when the Roland MCP Series (MIDI Compu Music) software is used.

SPECIFICATIONS

- **Control**

- Tune Knob (Approx \pm 100 cent)

- **Switches and Buttons**

- Power Switch

- Assign Mode Switch (I/II/III)

- Transpose Switch (H/M/L)

- MIDI Channel Switch (1 to 16)

- Hold Button

- Clear Button

- Tune Button

- Operation Mode Button

- (MONO, 2 VOICE, 3 VOICE, 4 VOICE, SPECIAL)

- **Indicators**

- Power Indicator

- Hold Indicator

- Gate Indicator (1 to 4)

- Operation Mode Indicator

- (MONO, 2 VOICE, 3 VOICE, 4 VOICE, SPECIAL)

- **Connectors**

- MIDI IN Connector

- MIDI OUT Connector

- MIDI THRU Connector

- CV Output Jacks (1 to 4)

- Gate Output Jacks (1 to 4)

- Dynamics Output Jacks (1 to 4)

- Pitch Bender Output Jack

- Modulation Output Jack

- Aftertouch Output Jack

- Volume Output Jack

- **Consumptions**

- 7W

- **Dimensions**

- 226(W) × 81(H) × 226(D)mm / 8⁷/₈" × 3³/₁₆" × 8⁷/₈"

- **Weight**

- 2.1 kg / 4 lb 10 oz

- **Accessories**

- MIDI/Sync Cable (1.5m) × 1

- **Options**

- MIDI/Sync Cable MSC-25/50

- Mini ↔ Mini Plug PCS-10/14

- Mini ↔ Standard Plug PCS-4

MPU-101

85-3-B3-1

 Roland