

MSQ-100

SERVICE NOTES

First Edition

SPECIFICATIONS

Memory Capacity : Approx. 6100 steps (one note/step)
 Tape Interface : 3200 baud
 Current Draw : 100mA @9VDC
 Power Consumption : 3W

Dimensions : 226(W) x 223(D) x 57(H) mm
 8-7/8(W) x 8-3/4(D) x 2-1/4(H) in
 Weight : 1.8 kg / 4 lb.

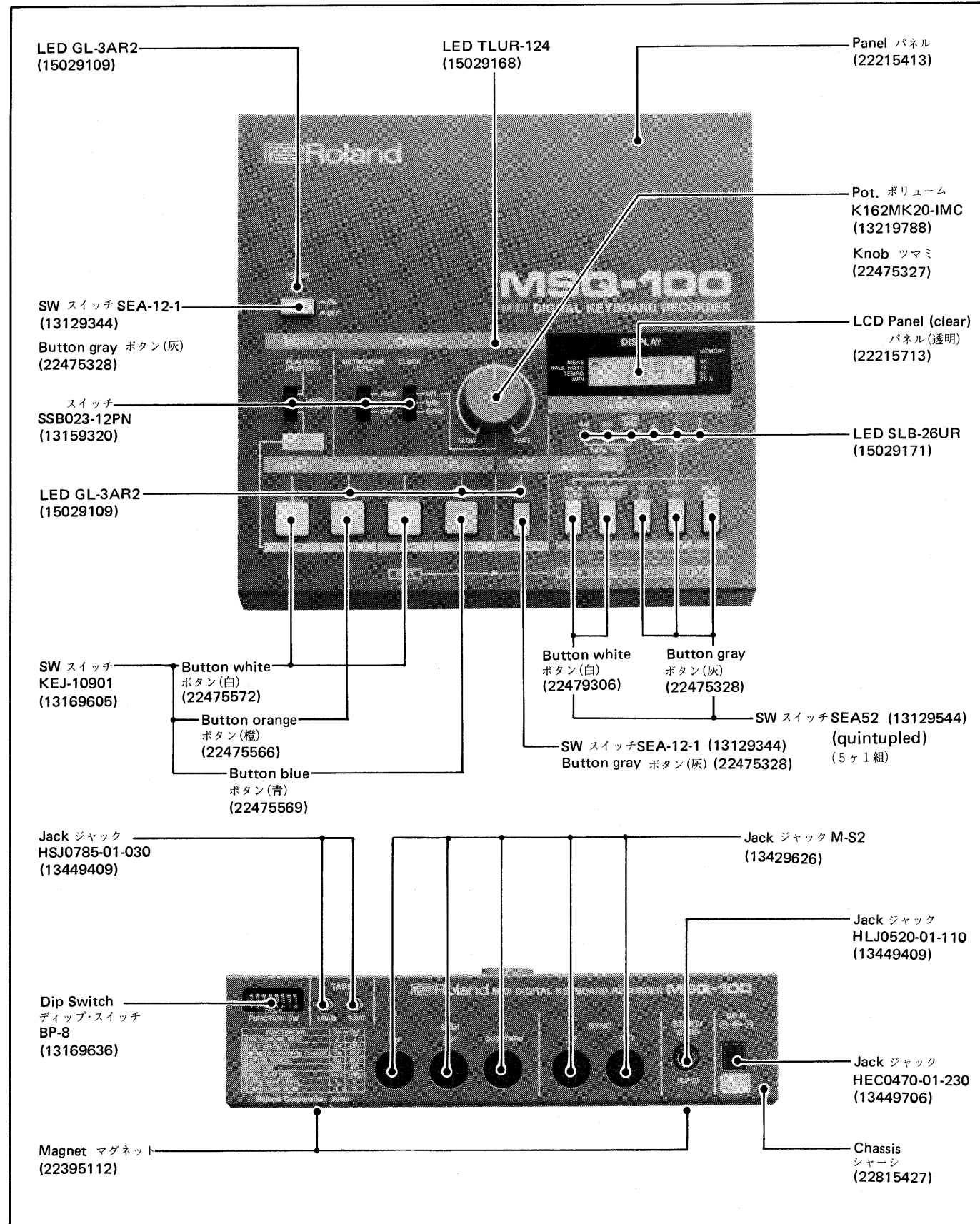

PARTS LIST

CASE ケース

22215413	Panel	パネル
22815427	Chassis	シャーシ
22215713	LCD Panel (clear)	LCDパネル
22395112	Magnet	マグネット

KNOB, BUTTON ツマミ、ボタン

22475327	Knob	ツマミ	TEMPO
22475566	Button(orange)	ボタン(橙)	LOAD
22475572	Button(white)	ボタン(白)	RESET, STOP
22475569	Button(blue)	ボタン(青)	PLAY
22479306	Button(white)	ボタン(白)	FWD MEAS, BACK MEAS
22475328	Button(gray)	ボタン(灰)	POWER, REPEAT PLAY, TIE, RESET, MEAS END

SWITCH スイッチ

13169605	KEJ-10901	プッシュ	push
13129344	SEA12-1	プッシュ	push
13129544	SEA52	プッシュ	push
13159320	SSB023-12PN	スライド	slide
13169636	BP-8	ディップ	dip

PCB ASS'Y 基板完

79335100	Sequence Board(pcb 22915925)	シーケンス基板 with LCD Board LCD基板付
----------	------------------------------	-------------------------------

JACK ジャック

13449125	HLJ0520-01-110	START/STOP
13449409	HSJ0785-01-030	LOAD, SAVE
13449706	HEC0470-01-230	DC9V IN
13429626	M-S2	MIDI, SYNC

COIL コイル

12449244	ELE-A120KA 12μH
----------	-----------------

POTENTIOMETER ポリウム

13219788	K162MK20-1MC	TEMPO trimmer
13299137	RVF8P01-104 100KB	半固定

RESISTOR ARRAY 抵抗アレイ

13919148	RGSD7x103K 10Kx7
----------	------------------

IC

15179188	HD6301X0A11P	CPU
15179659	2764-659	EP-ROM
15179335	HM6264 LP-15	RAM
15179322	HM6116 P-4	RAM
15169509	MN1252B	LCD driver
15169316	74LS125	quad bus buffer gate with 3-state output
15159514	TC40H032P	quad 2-input OR gate
15159506	TC40H138P	3 to 8 line decoder/demultiplexer
15159511	TC40H174P	Hex D-Type Flip-Flop
15159124	TC4093BP	Quad 2-Input NAND Schmitt Trigger

15159303	TC4584BP	Hex Schmitt Trigger
15149114	M54527P	Transistor Array
15189146	IR9022	Low-Power OP Amp
or		
15189115	TL022CP	Low-Power OP Amp

DIODE ダイオード

15019120	1S2473	
15019208	1SR35-200	
150196130X	05Z5.6X	ツェナー zener
15029109	GL-3AR2	LED
		(POWER, LOAD, PLAY, REPEAT PLAY)
15029168	TLUR-124	LED (TEMPO)
15029171	SLB-26UR	LED (LOAD MODE)

TRANSISTOR トランジスタ

15129815	2SD880 0	(or 15129816 2SD880 Y)
15129141	2SC1740 Q	(or 15129113 2SC1740 R)
15119106D0	2SA933 Q	(or 15119106DR 2SA933 R)

CAPACITOR コンデンサ

13589501	FZOH473Z 0.047F/5.5V	high-capacitance, low-leakage, high-impedance, non-polarized, miniature capacitor for RAM back up
----------	----------------------	---

CONNECTOR コネクタ

13439245	3022-19B 19pin	LCD Board
23450905	rubber conductor	contact
23430513	rubber connector	spacer

OTHERS その他

12389715	KMFC1002T 4MHz	Xtal (ceramic resonator)
12389723	PKM37-3A0	ブザー Buzzer
15229706	TLP552	Photo Coupler フォト・カプラ
15029408	EDD063M04B3	LCD

AC ADAPTOR ACアダプタ

(Commercially available. Only for reference.) (別売品)			
12449509	PSA-100	option	(100V)
12449510	PSA-120	option	(117V)
12449511	PSA-220	option	(220V)
12449512	PSA-240	option	(240V)

BLOCK DIAGRAM

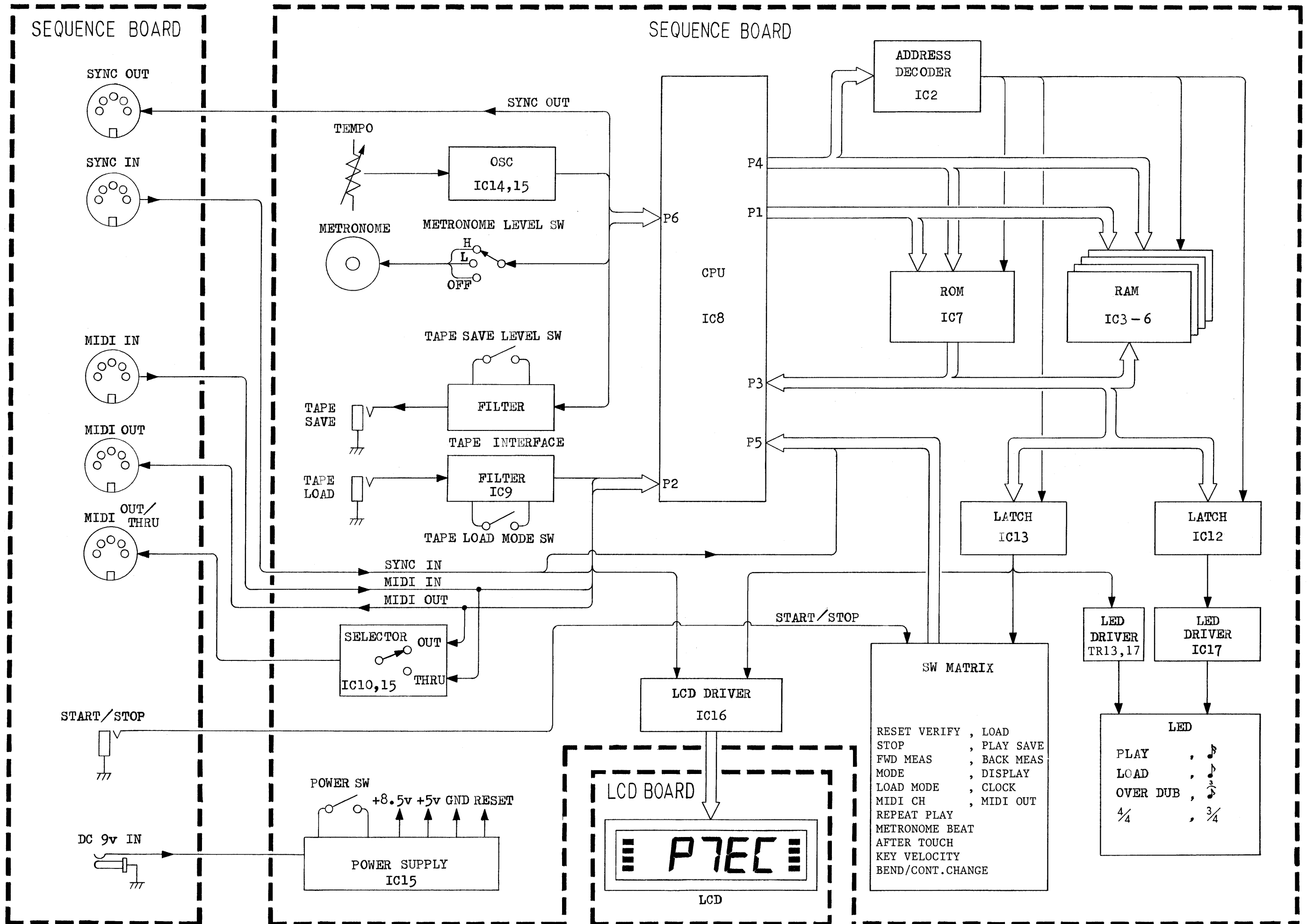

CIRCUIT DESCRIPTIONS

CPU 6301XOA11P Pin Connection

DESIGNATION	PIN NO.	FUNCTION	NOTE		
Port-1	P1-0	Address LSB 8 bit out (A0-A7)			
	1			49	
	2			48	
	3			47	
	4			46	
	5			45	
	6			44	
	7			43	
Port-2	P2-0	* During Tape Mode: Reads data from the tape. * During SYNC Mode: Reads Clock through SYNC.			
	1	10		Data write strobe to LCD driver	
	2	11		LCD driver Chip Select	
	3	12		MIDI Serial Input	
	4	13		MIDI Serial Output	
	5	14		SYNC Clock Enable	Both of these signals don't go HIGH simultaneously.
	6	15		TAPE DATA Enable	
	7	16		N.C.	
Port-3	P3-0	DATA BUS (D0-D7) Program read (EXT. ROM) Data read & write (RAM) Data write (Latch)			
	1			57	
	2			56	
	3			55	
	4			54	
	5			53	
	6			52	
	7			51	
Port-4	P4-0	Address MSB 8 bit out (A8-A15)	MSB 3 bits are decoded at IC2 (40H138)		
	1			40	
	2			39	
	3			38	
	4			37	
	5			36	
	6			35	
	7			34	
Port-5	P5-0	17	SYNC START/STOP Input	Constantly HIGH	
	1	18	N.C.		
	2	19			
	3	20	SW read		
	4	21			
	5	22			
	6	23			
	7	24			

DESIGNATION	PIN NO.	FUNCTION	NOTE		
Port-6	P6-0	25	Program mode read		
	1	26	Tempo OSC control		High = Start Low = Stop
	2	27	SYNC start/stop output		
	3	28	SYNC clock output		
	4	29	Metronome trigger out		
	5	30	Metronome accent control		
	6	31	Output for Tape Save Data		
	7	32			
XTAL	2	Input for internal clock OSC.			
EXTAL	3				
MP0	4	Sets Operation Mode in the CPU.	Low High } Mode 2		
MP1	5				
RES	6	Reset Input			
STBY	7	Constantly high			
NMI	8	Tempo OSC Input			
WR	62	RAM/LATCH write pulse out			
RD	63	RAM/ROM read pulse out			
BA	59	N.C.			
LIR	60				
R/W	61				
E	64				
Vcc	33	+5V			
Vss	1	GND			
Vss	42				

CPU IC8 HD6301XOA11P

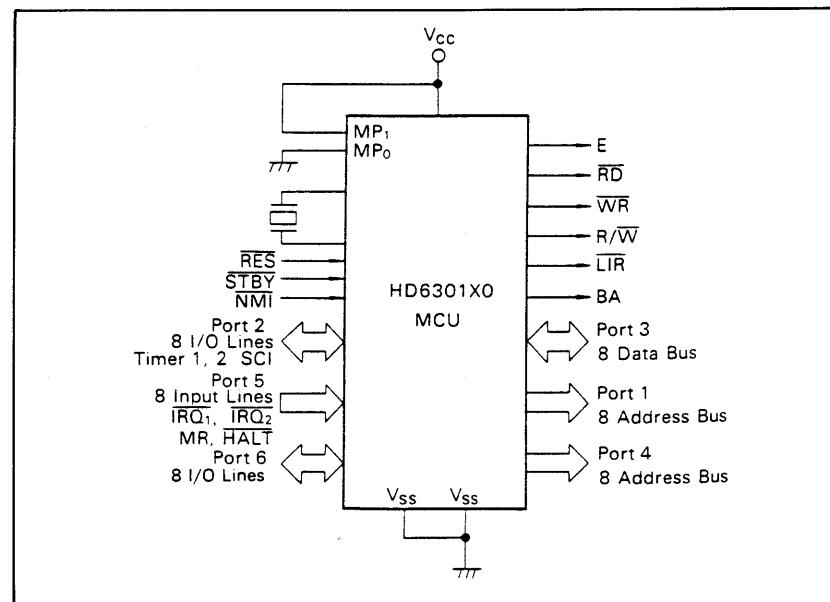

IC8 HD6301XOA11P is a CMOS 8-bit microcomputer unit (MCU) that incorporates a 4k-byte ROM, a 192-byte RAM, a serial communication interface (SCI), parallel I/O ports, a 16-bit programmable timer, and an 8-bit re-load type timer. IC8 has three operation modes. Of these, MSQ-100 uses the expanded mode which is Mode 2.

ROM, RAM, & LATCH

Functions of each device are described below.

IC4-IC16(RAM): Store a sequence of the note and associated data. The DC rail to V_{DD} of these RAMs bypasses the Power Switch, keeping the data even the switch is OFF as long as AC adaptor is live. Moreover, these RAMs can retain data for about 24 hours after disconnection of the AC sources; a super capacitor C1 in the V_{DD} rail has a capacitance of 0.047F (no that's not a typographical error of μF—it's 0.047 farads)

IC3 (Working RAM): A general-purpose RAM used by the CPU.

IC7 (ROM): External program area

IC12 (LATCH): Latches the LED drive data.

IC13 (LATCH): Outputs the LED drive, LCD display, and the switch scan signal.

Data Latch Timing Chart (IC13 to IC16)

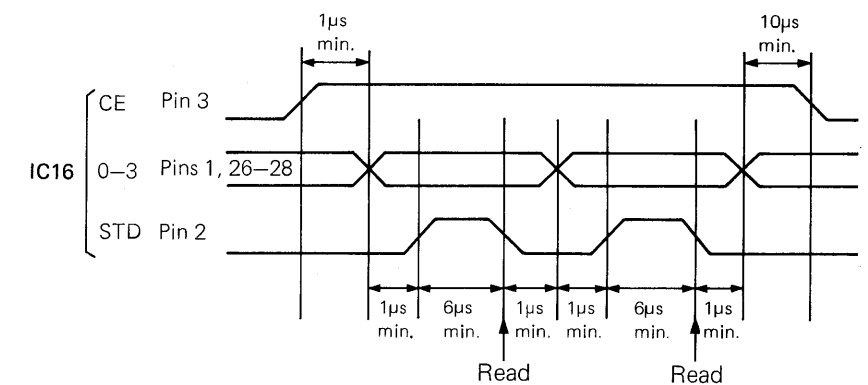

RESET

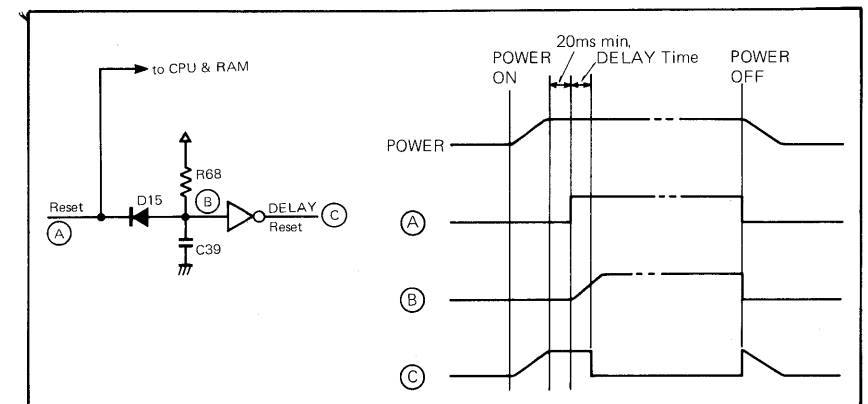

The MSQ-100 incorporates the hardware that provides the software with enough time for completing initialization. The hardware includes the Reset and associated circuit. The hardware also protects RAM memories against transients on power-up and power-down.

RESET

During power ON, TR10 remains ON and TR9 OFF. On power-up, pin 12 of IC15 is forced to and remains low until currents flowing through R51 charge C34 to the threshold voltage at pin 1 of IC15 (A in the figure). This low disables RAMs IC4-IC6 and resets IC8.

INVERTED/STRETCHED RESET

Transients of RESET output are fed through RC time constant to pin 9 of IC15 (B in the figure) where they are inverted (C in the figure) and routed to the following points.

TO TR5 which cuts off DC supply to MIDI OUT sockets, muting MIDI bus until the CPU is ready for output useful information.

TO TR15 which forces $\overline{\text{NMI}}$ (pin 8 of CPU IC8) to high through IC14, letting the CPU not to accept any input to the NMI terminal. Otherwise, the CPU may run out of program.

TO PIN 13 OF IC10 which connect to P5-3 (pin 20) of IC8 CPU.

This terminal is designed to serve as a HALT terminal once the CPU is reset. This function, however, is not required for the MSQ-100 performance and will be canceled by the program when the initialization is finished. During the initialization, HALT is kept high by a high-impedance state buffer (pins 11–13) in IC10 LS125. The reason is as follows.

If P5-3 receives a low such as caused by START/STOP pedal, CLOCK INT or MIDI OUT, the CPU enters unwanted HALT mode, stopping entire operation until the release of that switch.

POWER-DOWN RESET

Discharge from C32 reverse-biases TR10, turning it OFF and turning TR9 ON. This causes collector of TR9 (and A in the figure) to quickly go low as soon as the power is OFF. As a result, access to RAMs is inhibited.

SWITCH READ

The CPU reads the scan pulses sent out of IC13 pins 5, 7, 10, and 12 through P5-3, 4, 5, 6, and 7 (pin 20–24). This allows the CPU to constantly recognize the status of all switches. Scan pulses are sent out, e.g. at about 400 μ s intervals during STOP mode.

SWITCH MATRIX

IC13 IC8	PIN 5	PIN 7	PIN 10	PIN 12
P5-3 PIN 20	MIDI OUT SW15-5	MIDI CH. SW14	START/STOP PEDAL	CLOCK INT SW-4
P5-4 PIN 21	AFTER TOUCH SW15-4	DISPLAY SW13	PLAY/SAVE SW8	CLOCK SYNC SW-4
P5-5 PIN 22	CONT. CHANGE SW15-3	LOAD MODE SW12	STOP SW7	PLAY ONLY SW-2a
P5-6 PIN 23	KEY VELOCITY SW15-2	FWD MEAS SW11	LOAD SW6	DATA TRANS SW2a
P5-7 PIN 24	METRONOME BEAT SW15-1	BACK MEAS SW10	RESET/VERIFY SW5	REPEAT PLAY SW9a

TEMPO CLOCK OSCILLATOR

With INT (internal) selected from the front panel, notes are stored or reproduced in tempo with the internal clock, the rate of which is controlled via TEMPO knob on the panel. The time base is 120 clocks/quarter note.

This oscillator is enabled whenever pin 8 of IC14 is high. When the pin 8 is low, the output (NMI) remains high.

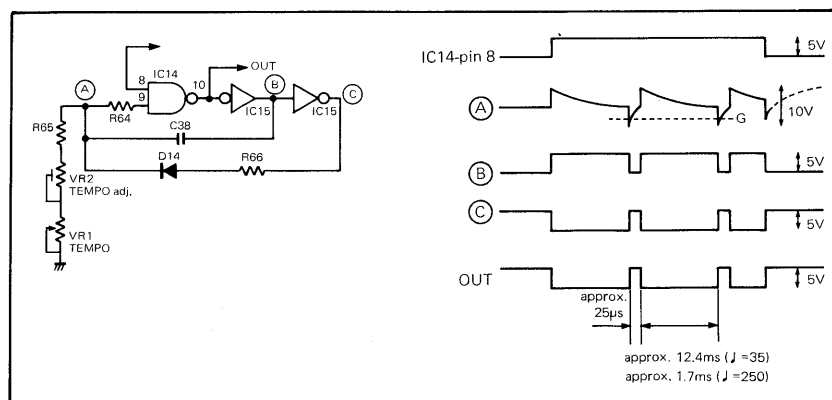

METRONOME

When the unit is either in Real Time Load, Tape or Play mode, TR12 turns ON at the negative going rate of P6-4 of IC8, switching ON and OFF the buzzer return path. Dynamics control is accomplished by turning ON and OFF of TR11. That is, TR11 turns ON only when a low is applied to the base of TR14 from P6-5, reducing the impedance of the return path, thus making the sound louder.

TAPE INTERFACE

SAVE

The CPU first reads data stored in RAMs and sends them to the TAPE INTERFACE circuit via P6-6 pin 31 and P6-7 pin 32 in the form of 2-bit codes. These data are then converted into four level analog wave chain at the output of D/A converter comprising R3, 5, and 6. Using TAPE SAVE LEVEL SW15-7, the output signal level can be switched either to the MIC level or LINE level before reaching the SAVE jack.

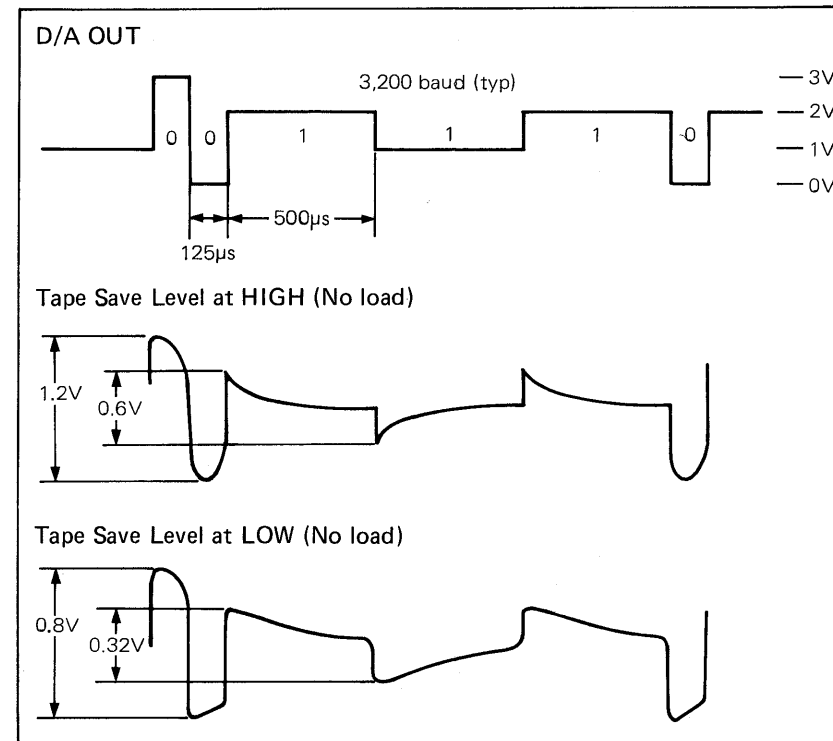

LOAD

When the unit enters TAPE LOAD Modes, IC8 P2-6 is high and P2-5 low, ignoring all signals from SYNC IN socket. The serial data from the tape is differentiated, amplified 120 times and then shaped into a rectangular by the comparator IC9a before entering IC8 P2-0 pin 9.

The CPU IC8 measures every edge of the rectangular and judges it as a 1 or a 0 according to the length: shorter than 256 μ s as a 0 and 256–1,024 as a 1. If the measurement accounts a period to be more than 1,024 μ s, the CPU ignores it and displays ERROR. The CPU stores valid data into RAM memories.

The differential circuit changes its frequency response either to +6dB/oct or +12dB/oct by the switching of TAPE LOAD MODE SW15-6.

VERIFY

The CPU checks the data loaded from the tape against the data stored in RAM for verification.

IC DATA

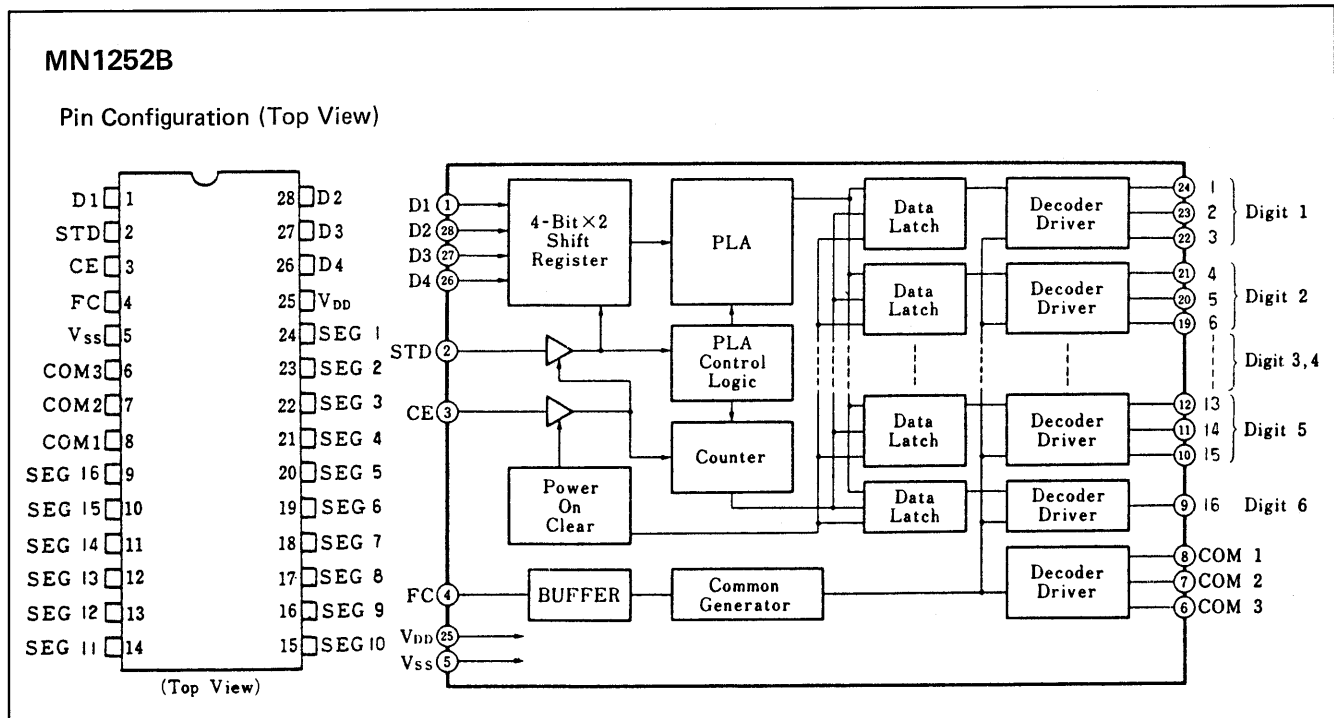
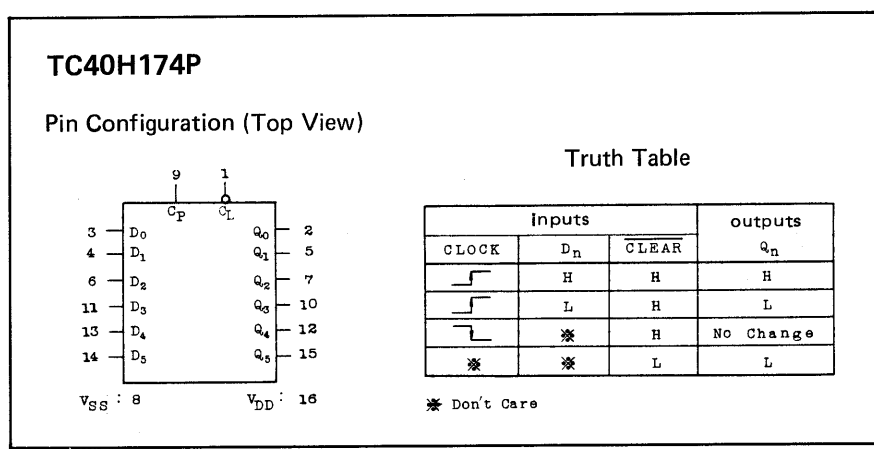
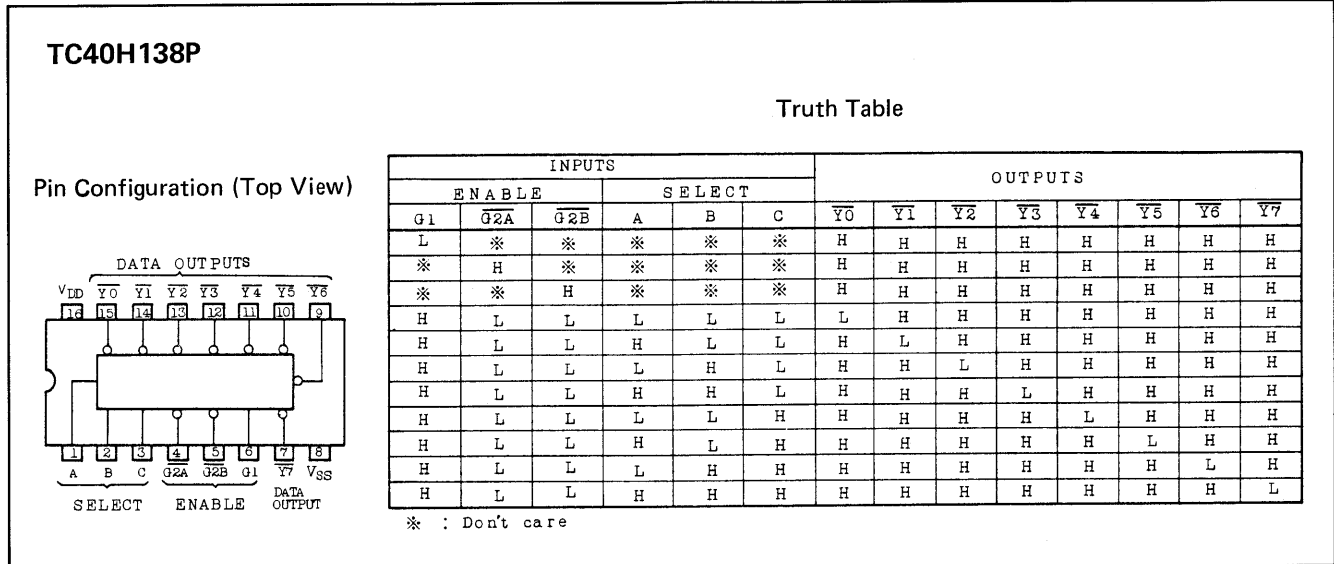
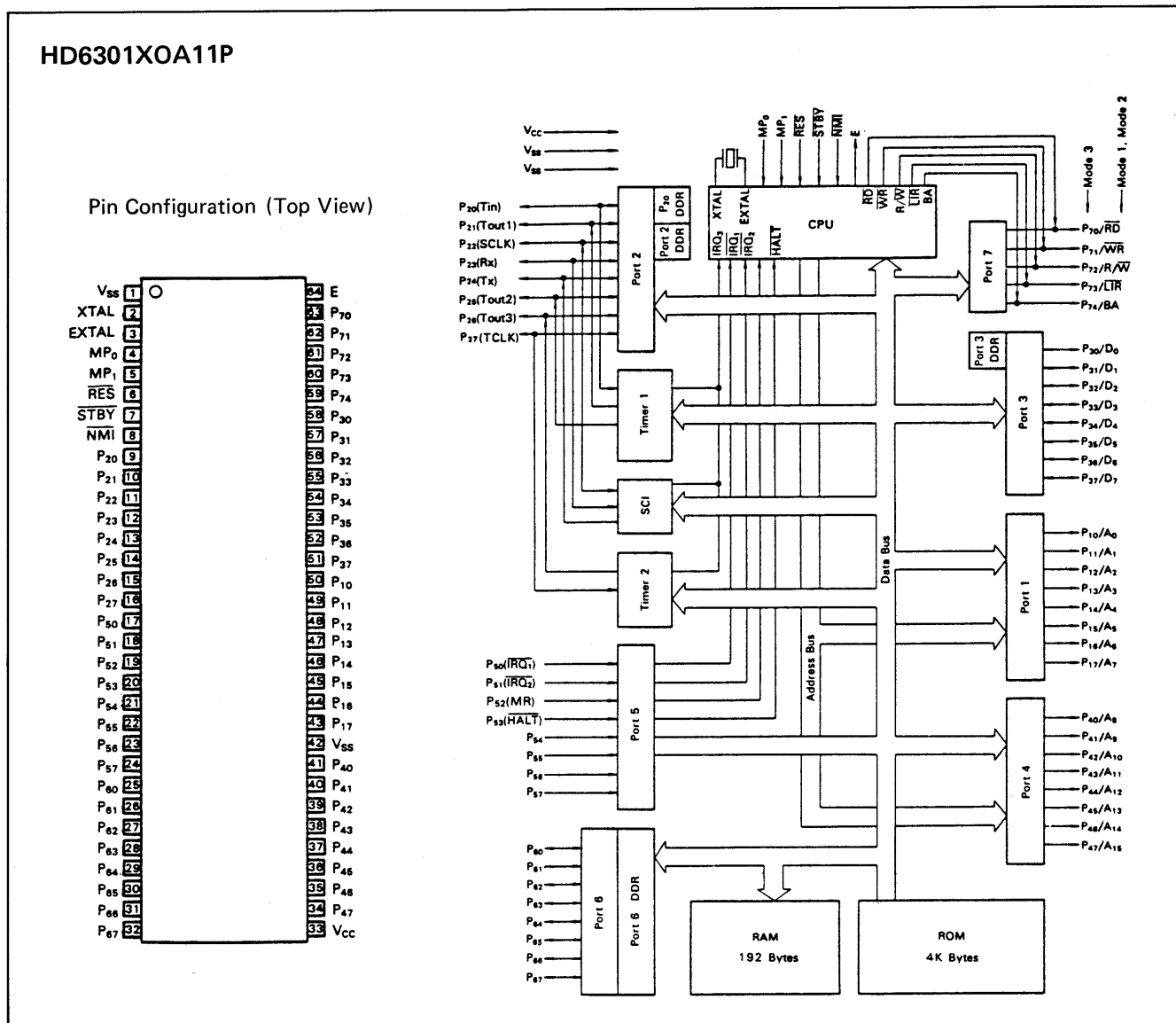

**PCB Assembly
SEQUENCE BOARD**

79335100
(pcb 22915925)

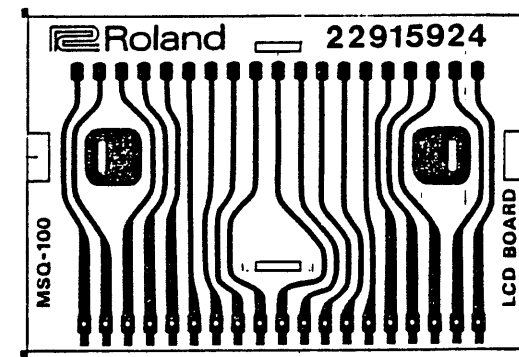

ADJUSTMENT

TEMPO

1. Turn TEMPO (VR1) fully clockwise (FAST).
2. While depressing SHIFT button (SW7), press T.CHECK button (SW14). The MSQ-100 is now in TEMPO CHECK mode and indicates a tempo in the display window.
3. Adjust VR2 for tempo reading 250 (up to SN 472949) or 260 (SN 472950-up).
4. Turn TEMPO fully counterclockwise (SLOW). The reading should be 35 and below.
5. Press STOP (SW7) to exit the Check mode.

TR1,2,6,8-18.....2SC1740 Q or R
TR3-5.....2SA993 Q or R
TR7.....2SD880

D 1-8,12,14,15,25-42.....1S2473
D 9.....1SR35-200
D 11.....05Z5.6X
D 10,22-24.....GL-3AR2
D 13.....TLUR-124
D 16-21.....SLB-26UR

Highest No.
IC17 TR18 D42 C47
R93 VR3 SW15 JK9

View from foil side

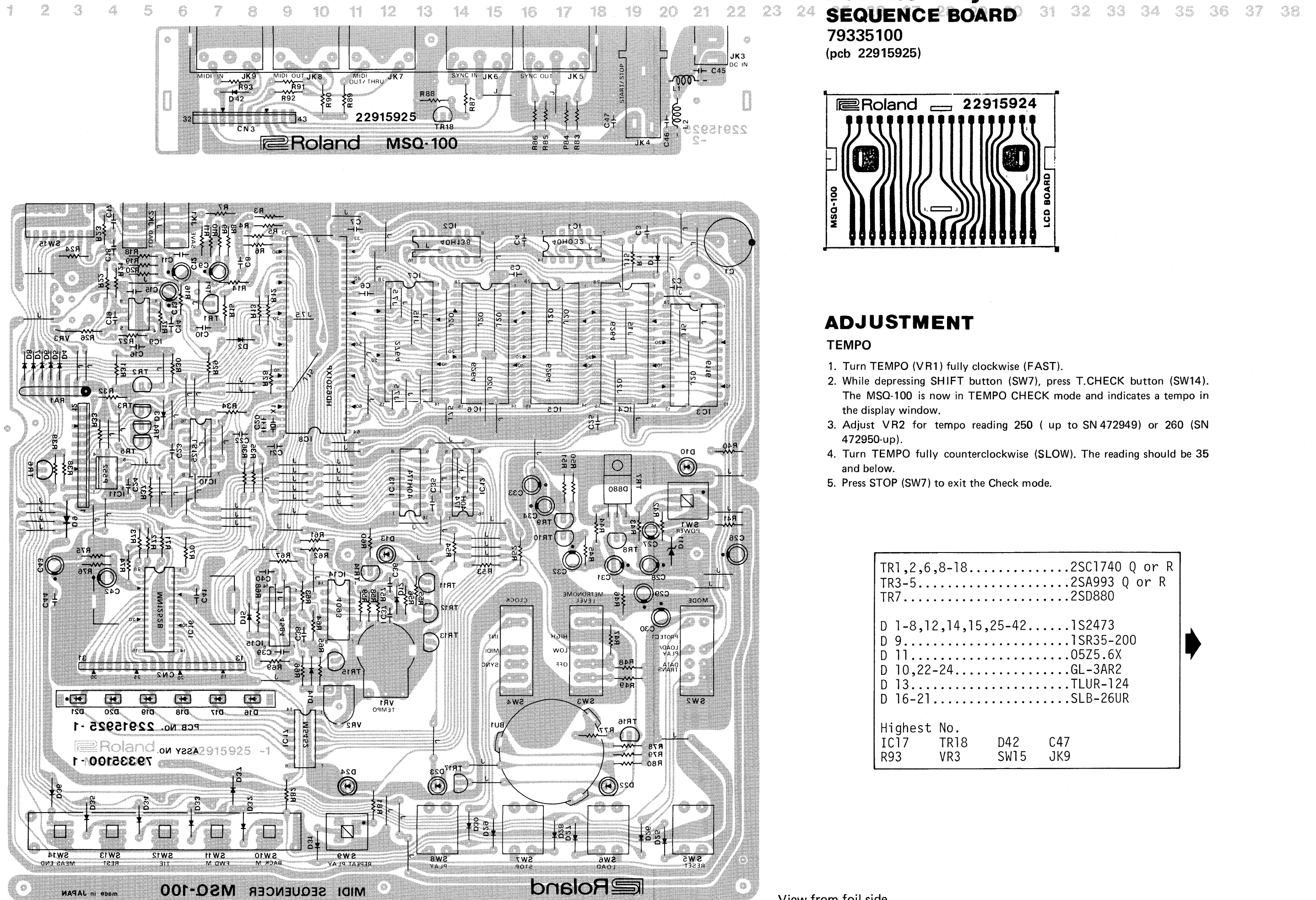

CIRCUIT DIAGRAM

1 2 3 4 5 6 7 8 9 10 11 12 13 14 15 16 17 18 19 20 21 22 23 24 25 26 27 28 29 30 31 32 33 34 35 36 37 38 39

A
B
C
D
E
F
G
H
I
J
K
L
M
N
O
P
Q
R
S
T
U

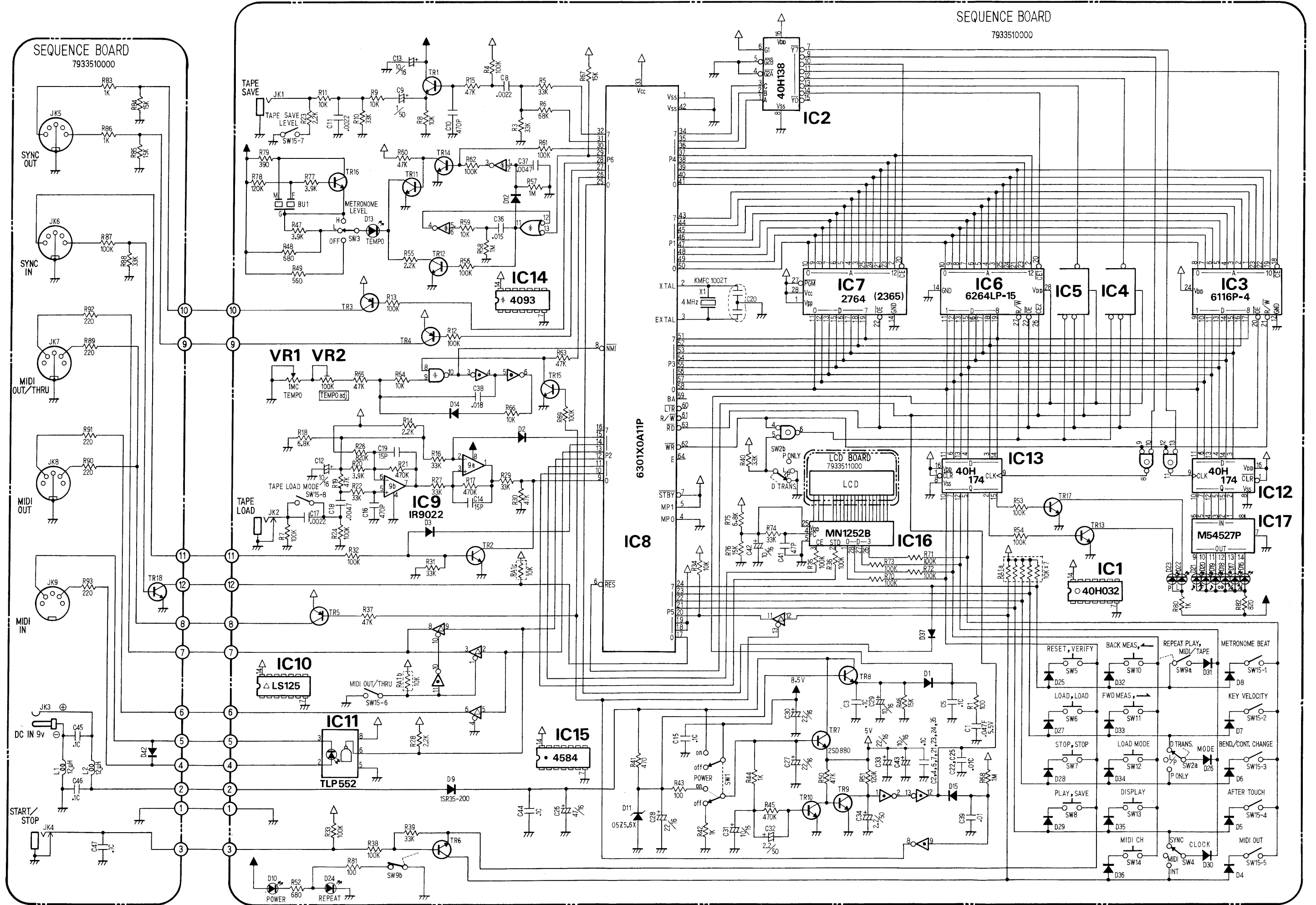

MIDI IMPLEMENTATION

1. RECOGNIZED RECEIVE DATA

March 30, 1984

1.1 Memorized messages while in LOAD mode

Status	Second	Third	Description	
1000 nnnn	Okkk kkkk	Ovvv vvvv	Note OFF	*1,2
1001 nnnn	Okkk kkkk	0000 0000	Note OFF	*1
1001 nnnn	Okkk kkkk	Ovvv vvvv	Note ON	*1,2
1010 nnnn	Okkk kkkk	Ovvv vvvv	Polyphonic Key Pressure	*3,4
1011 nnnn	Occc cccc	Ovvv vvvv	Control Change	*3,5
1100 nnnn	Oppp pppp		Program Change	*3
1101 nnnn	Ovvv vvvv		Channel Pressure	*3,4
1110 nnnn	Ovvv vvvv	Ovvv vvvv	Pitch Wheel Change	*3,6
1111 0000	0100 0001	0101 0111	0111 0000 0xxx xxxx	
	1111 0111 (EOX)		Sequence Data (Exclusive message)	*7

1.2 Recognized only

Status	Second	Third	Description	
1011 nnnn	0111 1011	0000 0000	ALL NOTES OFF	*8
1011 nnnn	0111 1100	0000 0000	OMNI OFF	*9
1011 nnnn	0111 1101	0000 0000	OMNI ON	*9
1011 nnnn	0111 1110	0000 mmmm	MONO ON	*9
1011 nnnn	0111 1111	0000 0000	POLY ON	*9
1111 0010	Oppp pppp	Oppp pppp	Song Position Pointer	*10

1.3 Recognized messages for sync.

Status	Description	
1111 1000	Timing Clock	*11
1111 1010	Start	*11
1111 1011	Continue	*11
1111 1100	Stop	*11

- Notes: *1 kkkkkk = 0 thru 120 (real), 0 thru 127 (recognized).
 *2 When KEY VELOCITY switch is OFF, vvvvvv = 1000000.
 *3 Memorized while in REALTIME LOAD mode.
 *4 When AFTER TOUCH switch on the rear panel is ON.
 *5 ccccccc = 0 thru 122 (BENDER/CONTROL CHANGE switch ON), 64 thru 95 (BENDER/CONTROL CHANGE switch OFF).
 *6 When BENDER/CONTROL CHANGE switch is ON.
 *7 While in MIDI LOAD or MIDI VERIFY mode.
 *8 When any one of notes is ON, this unit creates NOTE OFF messages for all ON notes.
 *9 Recognized as only an ALL NOTES OFF.
 *10 While in STOP mode.
 *11 When the CLOCK switch is set to MIDI.

2. TRANSMITTED DATA

2.1 All memorized messages while in PLAY mode.

2.2 All received messages.

*1

2.3 Internally created messages.

Status	Second	Third	Description	
1111 1000			Timing Clock	
1111 1010			Start	
1111 1011			Continue	
1111 1100			Stop	
1011 nnnn	0111 1011	0000 0000	ALL NOTES OFF	*2
1011 nnnn	0111 1100	0000 0000	OMNI OFF	*3
1011 nnnn	0111 1111	0000 0000	POLY ON	*3
1111 0010	Oppp pppp	Oppp pppp	Song Position Pointer	*4
1111 0000	0100 0001	0101 0111	0111 0000 0xxx xxxx	
	1111 0111 (EOX)		Sequence Data (Exclusive message)	*5

- Notes: *1 When MIDI OUT switch is set to MIX. (While in PLAY or OVER-DUB mode, received Mode Messages are not transmitted.)
 *2 When all notes turn OFF.
 *3 On power up, these MODE MESSAGES are transmitted for all channels.

- *4 When one of FWD MEAS, BACK MEAS or RESET is pressed.
 *5 While in MIDI SAVE mode.

3. EXCLUSIVE MESSAGE for MSQ-100 Sequence data

Byte	Description
a 1111 0000	Exclusive status
b 0100 0001	Roland ID #
c 0101 0111	function type
d 0111 0000	Data type = 7-8 conversion
e 0nnn nnnn	message #, 0 - 127
f 0xxx xxxx	Encoded data, 256 bytes max (See note) 0... ..
g 0sss ssss	Check sum (encoded data only)
h 1111 0111	(EOX)

Note: Each 8 bytes includes encoded 7 data bytes as follows:
 Check sum: f1 + f2 + = g

Bit format of data to be encoded.

Bit	7	6	5	4	3	2	1	0
byte of data								
first	1-7	1-6	1-5	1-4	1-3	1-2	1-1	1-0
second	2-7	2-6	2-5	2-4	2-3	2-2	2-1	2-0
third	3-7	3-6	3-5	3-4	3-3	3-2	3-1	3-0
4th	4-7	4-6	4-5	4-4	4-3	4-2	4-1	4-0
5th	5-7	5-6	5-5	5-4	5-3	5-2	5-1	5-0
6th	6-7	6-6	6-5	6-4	6-3	6-2	6-1	6-0
7th	7-7	7-6	7-5	7-4	7-3	7-2	7-1	7-0

Encoding Bit format for MIDI.

Bit	7	6	5	4	3	2	1	0
byte of MIDI								
first	'0'	7-7	6-7	5-7	4-7	3-7	2-7	1-7
second	'0'	1-6	1-5	1-4	1-3	1-2	1-1	1-0
third	'0'	2-6	2-5	2-4	2-3	2-2	2-1	2-0
4th	'0'	3-6	3-5	3-4	3-3	3-2	3-1	3-0
5th	'0'	4-6	4-5	4-4	4-3	4-2	4-1	4-0
6th	'0'	5-6	5-5	5-4	5-3	5-2	5-1	5-0
7th	'0'	6-6	6-5	6-4	6-3	6-2	6-1	6-0
8th	'0'	7-6	7-5	7-4	7-3	7-2	7-1	7-0

* The sequence data is formatted as 'Q1' type data format.

4. 'Q1' type data format

A file of sequence data consists of a [FCB], [PD]s and a [ED].

4.1 [FCB] File control block

This is the file control block which contains fixed 40 bytes total. It is sent under an exclusive message.

Name	# of bytes	Description
a) Header	1 byte	\$FD
b) Block Type	1 byte	'F' in ascii
c) Data type	2 bytes	'Q' in ascii
d) File Name	30 bytes	'MSQ-100.0', 21 spaces
e) Conductor sw	1 byte	\$00, off
f) track #	1 byte	\$00, none of tracks
g) phrase #	2 bytes	\$01, \$00
h) time base	1 byte	\$78, time base = 120
i) tempo	1 byte	\$64, (no function)
j) EOB	2 bytes	\$FE, \$FE

4.2 [PD] Phrase data block

This block contains actual sequence data with time values. If the data is long, it may be divided.

Name	# of bytes	Description
a) Header	1 byte	\$FD
b) Block type	1 byte	'P' in ascii
c) Phrase id #	2 bytes	\$00, \$00
d) data	n bytes	MIDI data with time
e) EOB	1 or 2 bytes	\$FE, (\$FE)

4.3 [ED] End block

This block is sent at the end of a file.

Name	# of bytes	Description
a) Header	1 byte	\$FD
b) Block type	1 byte	'E' in ascii
c) Data type	2 bytes	\$00, \$00 (dummy)
d) EOB	2 bytes	\$FE, \$FE

5. Phrase data format

	1st byte	2nd byte	3rd byte	4th byte
normal MIDI voice messages				
0 - 239		(\$80 - \$EF) *	0 - 127	0 - 127
time		MIDI status	key #	vel
time overflow				
248 (\$F8)				
CPU status				
measure end		\$F9		
0 - 239				
time		MPU mark		
BPM change (beat per measure)		\$FA	0	0 - 8 **
0				
time		special func	BPM	# of beat
change internal format				
0		\$FA	1	0, 127 ***
time		special func	INT format	switch
data end		\$FC		
0				
time		MPU mark		

- Notes: * Same MIDI status will not be sent.
 ** 0: data does not contain the MEASURE ENDS.
 *** 0: set internal data format not to maintain NOTE ON VELOCITY.
 127: set internal data format to maintain NOTE ON VELOCITY.

Example

0	\$90	60	54	120	64	43
t1=0	status	do	on	t2=120	mi	on
2	60	0	\$F8	120	64	0
t3=2	do	off	t=240	t4=120	mi	off
118	\$F9	\$F8	\$F8	0	\$F9	\$17
t5=118	ME	t=240	t=240	t=0	ME	t=23
						\$FC
						end

t1 - t5 time value, ME: measure end
 do, mi: name of note