



OWNER'S MANUAL

RS-505



Paraphonic-505

- PARAPHONIC 505 produces a new synthesizer sound with chords, based on the strings sound with the aid of synthesizer technology.

With a 3-channel output, this instrument produces a stereo effect as well as the monaural flow of sound and a rich, expressive dimension of music is yours with this mechanism.

- Please read the instructions carefully. To help you master the know-how of sound creation, there are some set-up examples provided at the end. But remember, you are the person at control. Don't limit yourself to just the sample sounds. Let your imagination run wild.

• SPECIFICATIONS

- **KEYBOARD**
(49-key 4-octave, C-scale)
- **STRINGS SECTION**
 - Tone Tablet 2
 - Upper Strings
 - Lower Strings
 - 4', 8' Mix Control..... 2
 - Upper, Lower
 - Attack Control 1
- **SYNTHESIZER SECTION**
 - Tone Tablet 6
 - Upper 4', Upper 8', Lower 4',
Lower 8', Bass 8', Bass 16'
 - Control Tablet 1
 - Ensemble
 - VCF Control..... 4
 - Cutoff Frequency
 - Resonance
 - ENV Sensitivity, LFO Sensitivity
 - Envelope Generator..... 4
 - Attack Time
 - Decay Time
 - Sustain Level
 - Release Time
 - Second Touch Switch..... 1
- **RELEASE CONTROL**
Strings + Synthesizer
- **BASS SECTION**
(Priority on lower note)
 - Tone Tablet 3
 - Cello 8', Tuba 16', Contrabass 16'
 - Control Tablet..... 1
 - Ensemble
 - Attack Control..... 1
 - Release Control 1
- **BALANCE**
Strings-Synthesizer
Bass Volume
- **ENSEMBLE SWITCH** 1
- **VIBRATO DEPTH** 1
- **LFO CONTROL** 2
 - Rate
 - Delay Time
- **TUNING** (over ± 50 cent.)
- **MASTER VOLUME**..... 1
- **PITCH SHIFT CONTROL**
 - Pitch Slider 1
 - Pitch Set (over 1 oct.) 1
 - Time 1
 - Pitch Mode Switch..... 1
 - AUTO
 - OFF/EXTERNAL CONTROL
 - MANUAL
- **ENSEMBLE TONE** (rear panel).... 1
- **POWER SWITCH** 1
- **CONNECTION JACKS**
 - AUDIO OUT Jack** 3
 - Monaural, Stereo, synthesizer +
Bass
 - OUTPUT Level Selection Switch**
..... 2
 - H: 0dBm/Imp. 6.3k Ω
 - M: -15dBm/8.6k Ω
 - L: -30dBm/2.2k Ω
 - (0dBm = 0.775vRMS, max.
10Vp-p)
 - GATE VOLTAGE OUTPUT JACK** . 1
 - OFF: 0v/ON: +15v
 - TRIGGER SIGNAL OUTPUT JACK**
..... 1
 - OFF: 0v/ON: +15v pulse, 2msec.
 - EXTERNAL CONTROL JACK** 3
 - VCF (FV-2), Sustain, Pitch (DP-2)
- **POWER CONSUMPTION**.... 12W
- **DIMENSIONS**
905(W) x 370(D) x 145(H)mm
35.6(w) x 14.6(D) x 5.7(H)in
- **NET WEIGHT** 14 kg
..... 31 lbs.
- **ACCESSORIES**
 - 2.5m hookup cord 2
 - Pedal Switch(DP-2)..... 1
 - Music Rack 1

*Specifications are subject to change without notice.

• BLOCK DIAGRAM

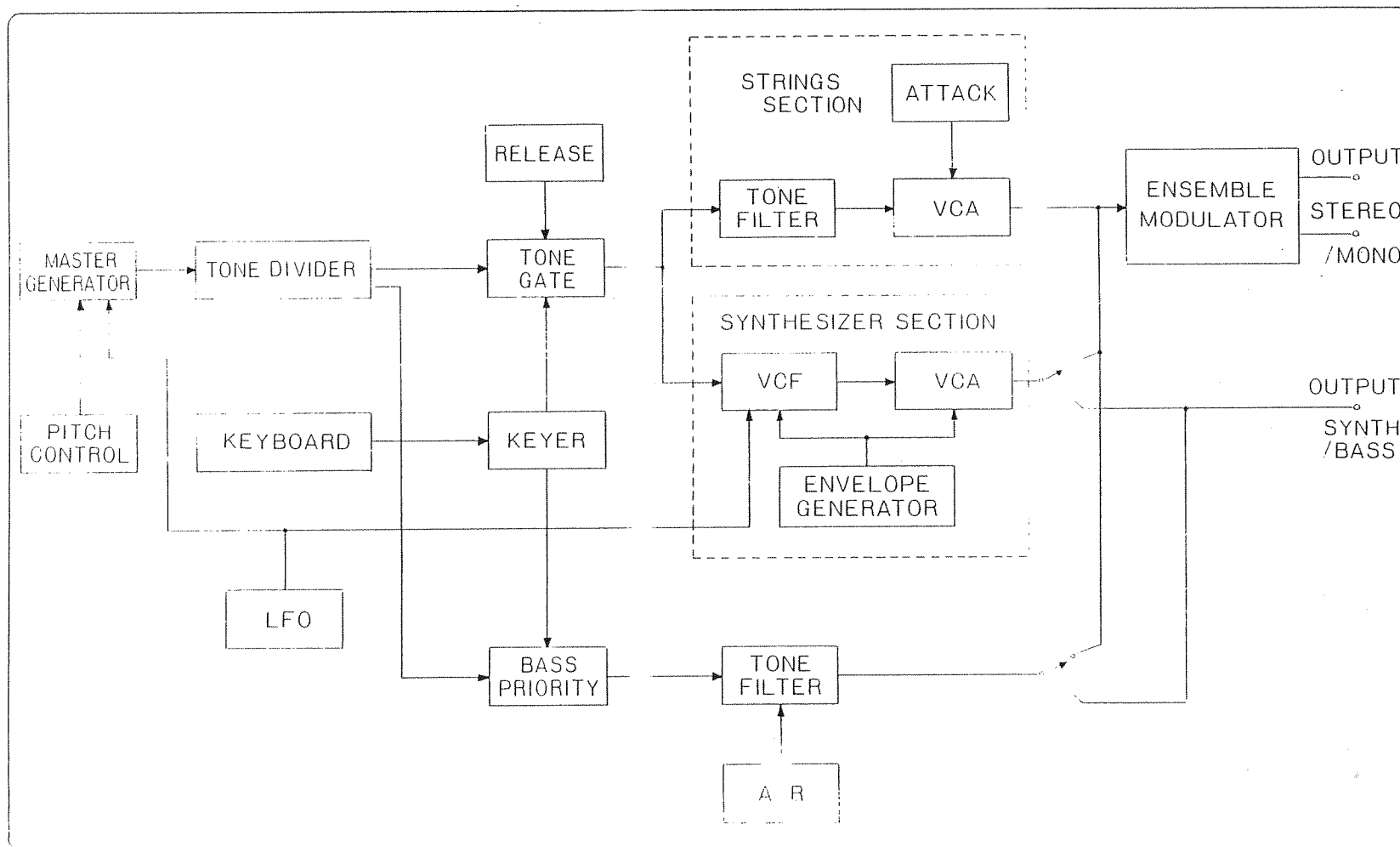



Paraphonic-505

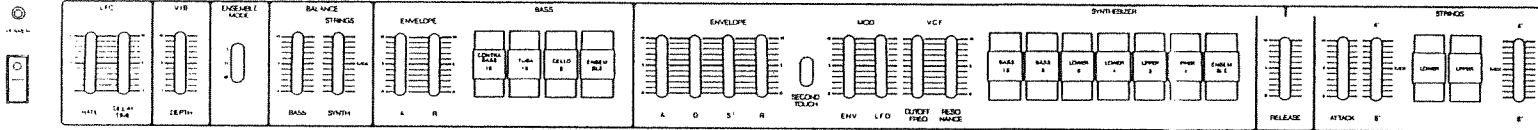

LOWER | UPPER

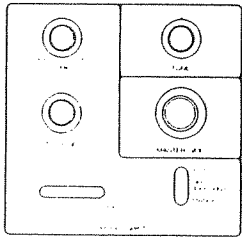

Paraphonic-505

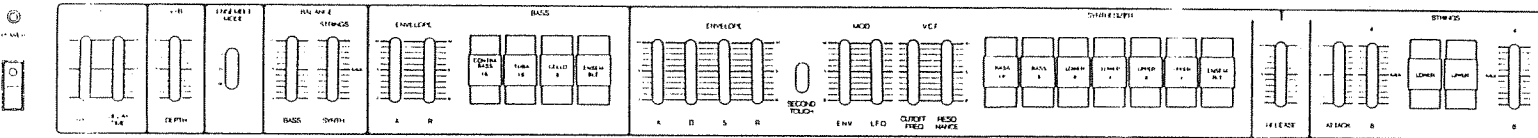

LOWER | UPPER

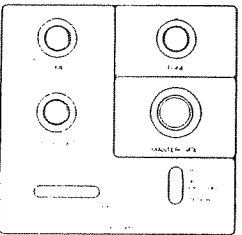



Paraphonic-505

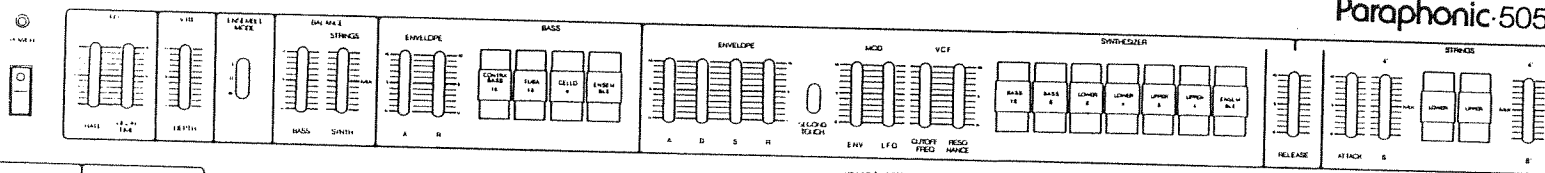

LOWER | UPPER

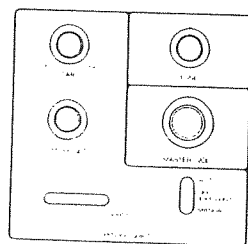

Paraphonic-505

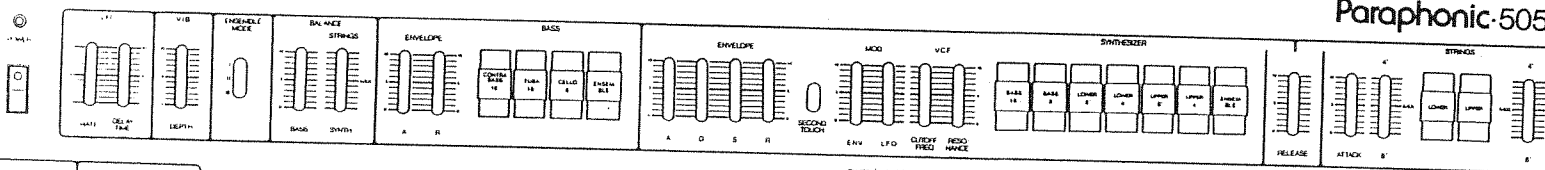

LOWER | UPPER

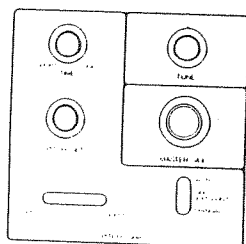



Paraphonic 505

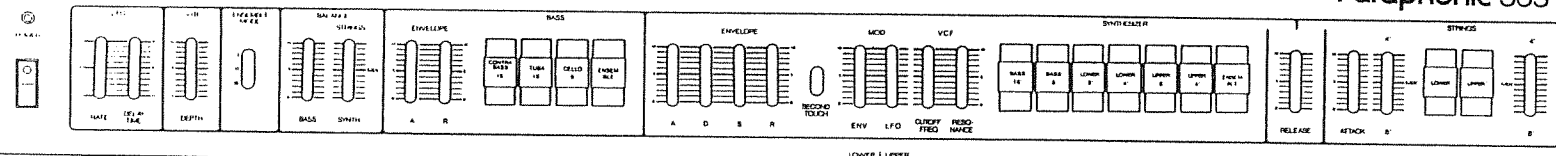

LOWER | UPPER

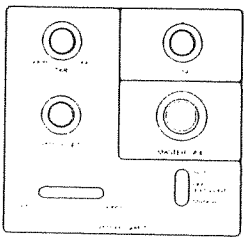

Paraphonic 505

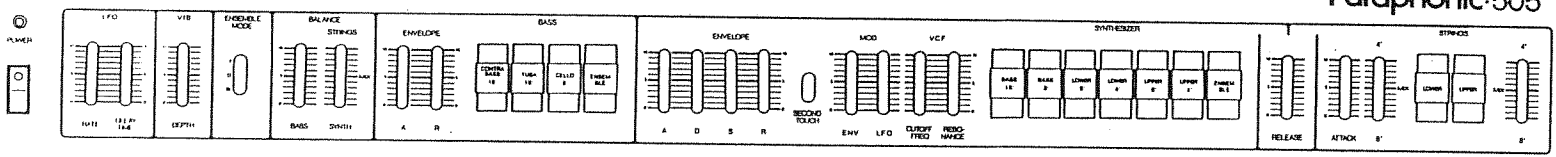

LOWER | UPPER

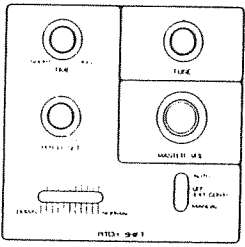



Paraphonic-505

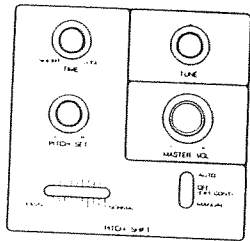
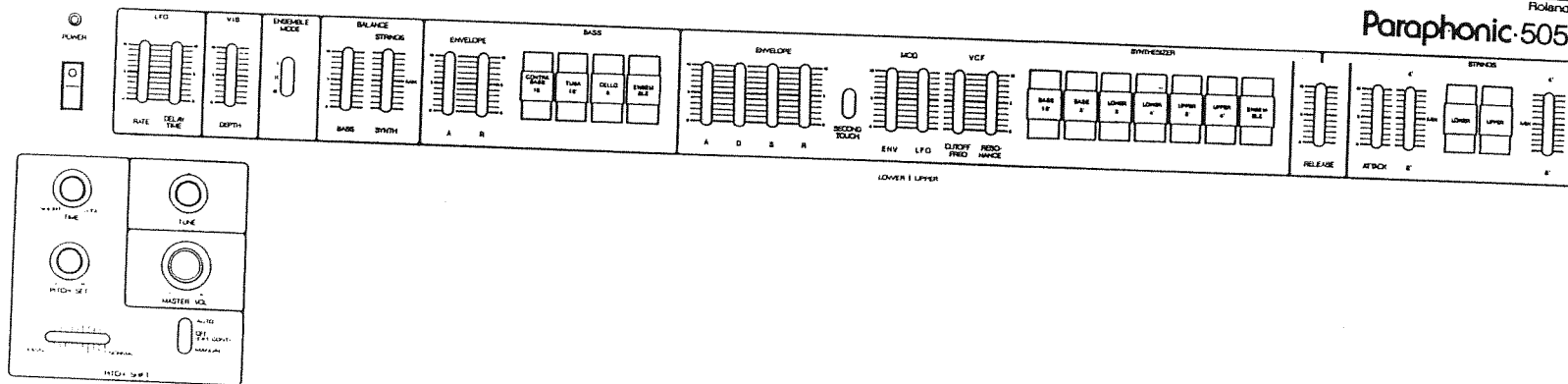

Paraphonic-505

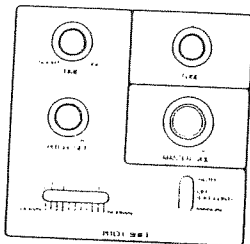
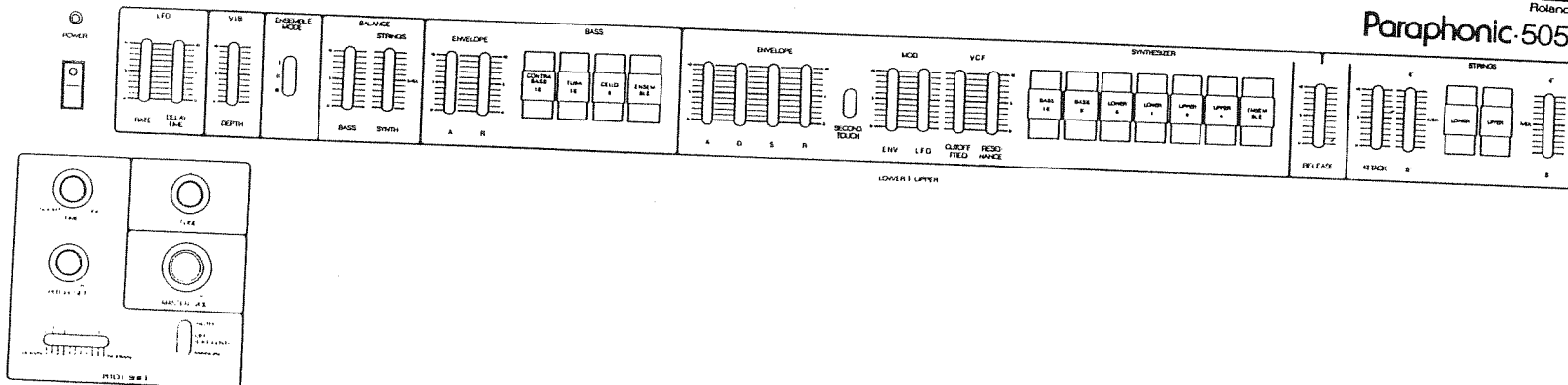

• SAMPLE NOTES

Roland
Paraphonic-505

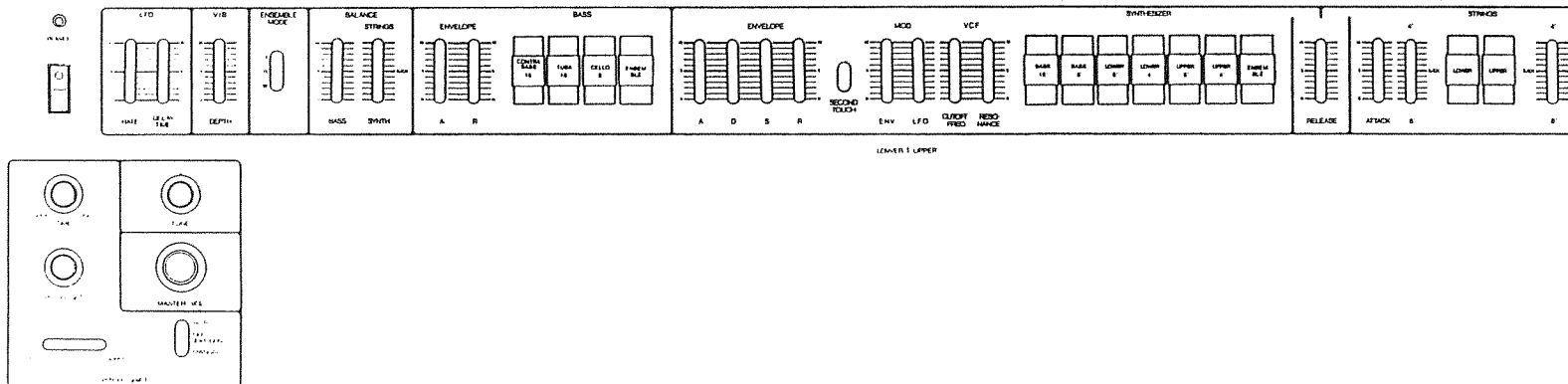

Roland
Paraphonic-505

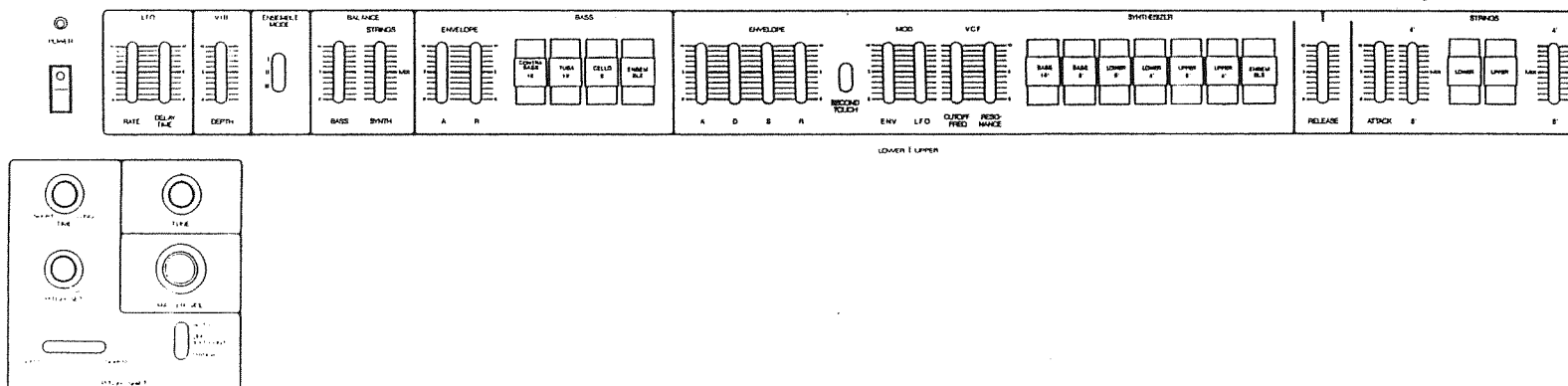

6. HAWAIIAN GUITAR

Connect the DP-2 (pedal switch) to the PITCH control jack on the rear panel. Lower the pitch by one octave with the PITCH SET knob. Release the pedal when coming to the note with "*" under it.

Musical score for Hawaiian guitar in G major, 4/4 time. The score consists of six measures. The right hand (R.H.) plays chords: Em7 (measures 1-2), C6 (measures 3-4), and G6 (measures 5-6). The left hand (L.H.) plays a bass line with notes: G2 (measure 1), B1 (measure 2), D2 (measure 3), F2 (measure 4), G2 (measure 5), and B1 (measure 6). Pedal markings 'P. Ped.' are shown below the staff, with asterisks (*) indicating when to release the pedal. The asterisks are located under the second measure of the C6 chord and the second measure of the G6 chord.

Control panel for a synthesizer, featuring various knobs, sliders, and buttons. The controls are organized into several sections:

- LEG:** Includes a slider for 'LEG' and a button for 'LEG ON/LEG OFF'.
- VIB:** Includes a slider for 'VIB' and a button for 'VIB ON/VIB OFF'.
- ENSEMBLE VOICE:** Includes a slider for 'ENSEMBLE VOICE'.
- BALANCE STRINGS:** Includes two sliders for 'BALANCE' and 'STRINGS'.
- ENVELOPE:** Includes a slider for 'ENVELOPE' and buttons for 'A' and 'H'.
- BASS:** Includes three buttons labeled 'CONTROL', 'TONE', and 'LAMP'.
- ENVELOPE (second):** Includes a slider for 'ENVELOPE' and buttons for 'A', 'D', 'S', and 'H'.
- MCD:** Includes a slider for 'MCD' and buttons for 'ENV', 'LFO', 'CUT OFF', and 'HOLD'.
- VCF:** Includes a slider for 'VCF' and buttons for 'HOLD' and 'HOLD'.
- SYNTHESIZER:** Includes a slider for 'SYNTHESIZER' and buttons for 'BASE', 'BASS', 'LOWER', 'LOWER', 'UPPER', 'UPPER', and 'HOLD'.
- RELEASE:** Includes a slider for 'RELEASE' and buttons for 'A' and 'B'.
- STINGS:** Includes a slider for 'STINGS' and buttons for 'A' and 'B'.

Below the main control panel is a separate section with four knobs labeled 'TAN', 'TAN', 'MAGNETIC', and 'MAGNETIC', and a slider for 'MAGNETIC'.

5. HARPSICHORD AND STRINGS

The score is from Vivaldi's "Four Seasons". The upper half of the keyboard is the harpsichord and strings ensemble sound and the lower half is the strings ensemble and bass sound. The attack time of the upper and lower strings is lengthened in order to enhance the sound of the harpsichord.

4. VIOLIN SOLO AND STRINGS

The score is from Gossec's gavotte. The upper half of the keyboard is the violin solo sound and the lower half is the strings ensemble sound. Remember the fact that the low notes have the first priority for the bass sound, while playing in legato.

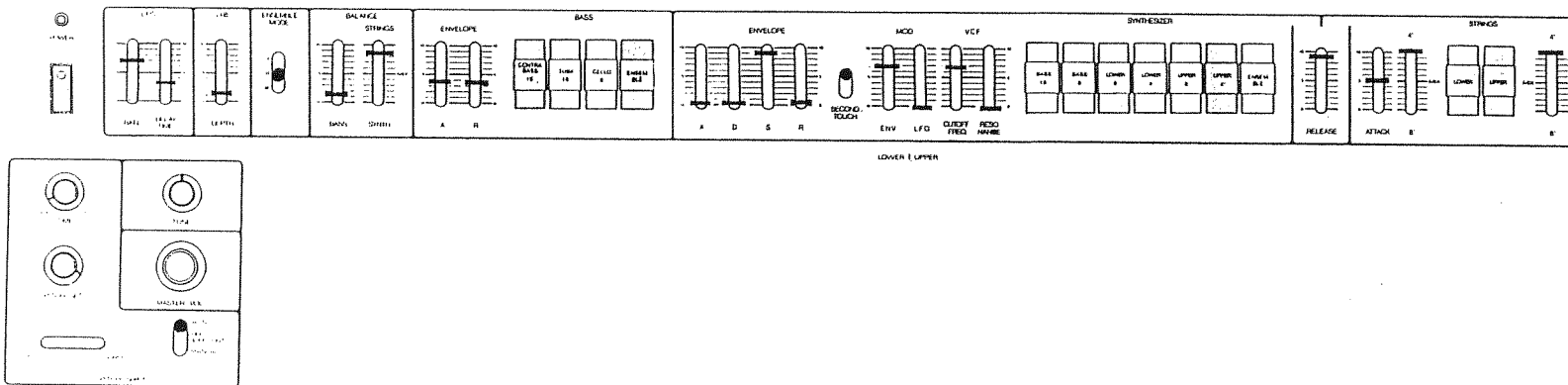

3. BRASS ENSEMBLE

This is the jazzy brass-like ensemble sound.

2. PIPE ORGAN

The score is from Bach's toccata and fugue. The use of an echo chamber will enhance the richness and expansion of sound.

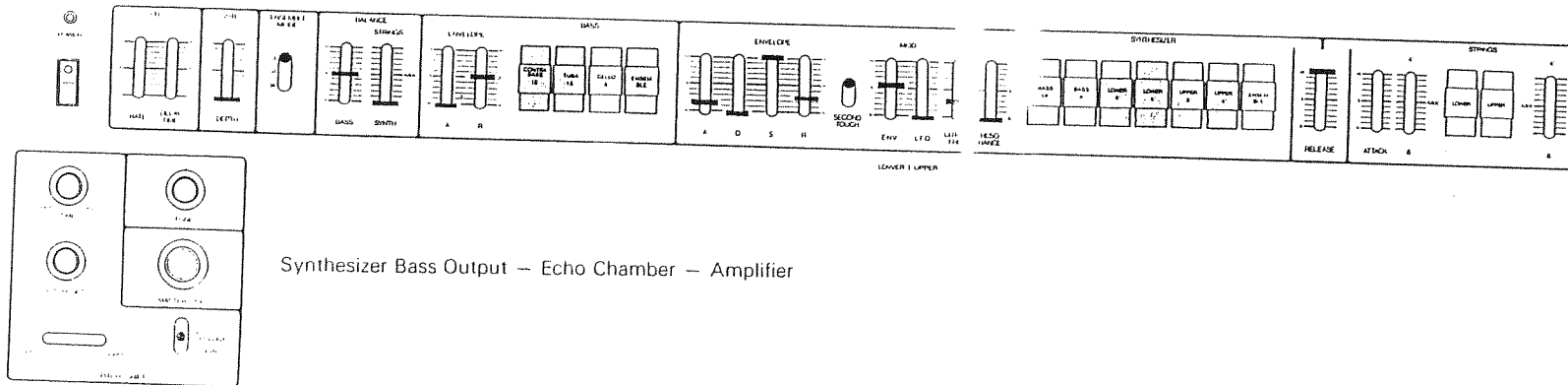

Synthesizer Bass Output - Echo Chamber - Amplifier

• SAMPLE SOUNDS

«REGARDING SETUP EXAMPLES»

Each slider is at a standard position. However the sound will vary depending on the amplifier and speakers used. Therefore,

make adjustments for final retouchings during performance. It is possible to create complicated sounds with this 505 model. However because of this there will be some limitations in performance. Therefore in producing instrumental sounds ef-

fectively certain techniques will be required. In practicing, please refer to the score examples.

Turn off the tablets and sliders that are not marked.

1. STRINGS SOUND

This is the most orthodox setup for the strings sound. The score below is the second movement from Dvorak's "From the New World." Legato performance is recommended.

The musical score is written for a grand staff (treble and bass clefs) in E-flat major (three flats). It consists of six measures. Above the staff, the chords for each measure are indicated: E, B^b, E, D^b, A, F[#]m, and D^b. The notes are arranged in a way that suggests a legato performance.

The control panel is divided into several sections:

- PARAMETER:** A vertical slider on the far left.
- TONE:** A slider with a vertical scale.
- DEPTH:** A slider with a vertical scale.
- STRENGTH:** A slider with a vertical scale.
- OSCILLATOR:** A section with two vertical sliders labeled 'OSCILLATOR' and 'OSCILLATOR'.
- ENVELOPE:** A section with two vertical sliders labeled 'ENVELOPE' and 'ENVELOPE'.
- BASS:** A section with four vertical sliders labeled 'BASS', 'BASS', 'BASS', and 'BASS'.
- ENVELOPE:** A section with four vertical sliders labeled 'ENVELOPE', 'ENVELOPE', 'ENVELOPE', and 'ENVELOPE'.
- RELEASE:** A section with two vertical sliders labeled 'RELEASE' and 'RELEASE'.
- ATTACK:** A section with two vertical sliders labeled 'ATTACK' and 'ATTACK'.
- STRENGTH:** A section with two vertical sliders labeled 'STRENGTH' and 'STRENGTH'.

Below the main control panel is a separate section with four knobs and two sliders, labeled 'TONE', 'TONE', 'MAGNETIC', and 'MAGNETIC'.

• TIME ⑦

For automatic or pedal control, this knob is for determining the length of time for the pitch shift to be completed. With AUTO, pitch shift becomes barely noticeable at SHORT. With pedal control, the difference in pitch will be noticed when the pedal is stepped on and then released. Setting PITCH SET to one octave will produce an effect similar to TRANSPOSE.

• PEDAL Control of the PITCH SHIFT

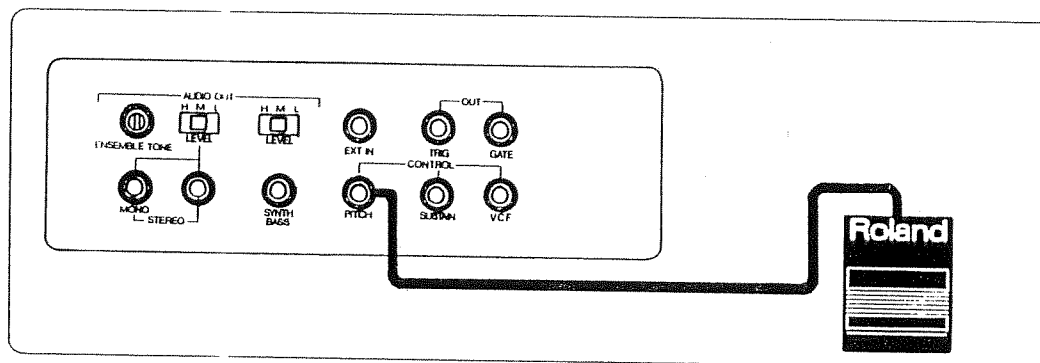

«For Understanding the PITCH SHIFT»

1. Set the Pitch Shift Mode ④ to MANUAL and PITCH SET ⑥ to L.
2. While producing a sound, move the Pitch Slider ⑤ from left to right.
 - You can control the pitch manually in this way.
3. Turn off the Pitch Shift Mode, set PITCH SET to H and set the Pitch Slider to DOWN. Try to remember the pitch of the key that you are pressing now.
4. Once again set the Pitch Shift Mode to MANUAL and PITCH SET to L. Set at two degrees below, or three, four, five degrees or one octave below. Turn off the switch once in a while to check the sound you originally produced.
 - In this way, the range in pitch shifting has been established. (At NORMAL, the shifted pitch will always return to its original pitch.)
5. At this state, set the Pitch Shift Mode to AUTO.
6. While pressing or releasing a key, turn the TIME ⑦ knob from SHORT to LONG.
 - PITCH SET is of a continuously variant nature. Therefore the shifting range will be easily set and re-set according to your preference.
 - At AUTO, as soon as the key is pressed, the sound produced will be of the pitch already determined with PITCH SET and will return to the original pitch within a length of time set with the TIME knob automatically. (In this case, the PITCH slider does not affect the process.)

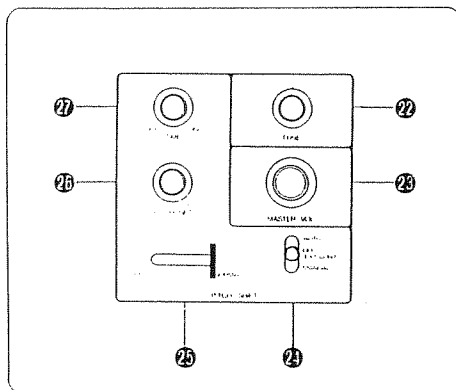

11 Tuning 21

This knob is for tuning the pitch of 505. The tuning range is approximately over high-low, 50 cent (1/4 of a note). It works for the Strings Section, the Synthesizer Section and the Bass Section. At the center position of the knob, it is tuned to A = 442 Hz. Use this knob for A = 440 or in tuning to other instruments.

12 Master Volume 23

This is the master volume knob for 505.

13 Pitch Shift

"Pitch Shift" is of the shifting of an interval. With 505, it is very easy to change the pitch and even have it climb back to the normal sound. Shifting can be done manually, automatically or with a pedal.

MANUAL

With a pitch slider, the pitch can be chosen from a range already established beforehand.

AUTO

Determine the starting note that will start the shift, which would be a few degrees lower than the normal note. Set the time length for this shifting process. Now press the key and the pitch will begin to rise. A key must be re-played for automatic control to work.

PEDAL CONTROL (EXT CONT)

Stepping on the pedal will continue producing the sound several degrees below the normal sound which you have set in advance. The moment you release the pedal the pitch shift will take place within a length of time assigned on the panel.

• Pitch shift mode 22

For pitch shift, select from AUTO, for automatic shifting, OFF/EXT CONT, for using pedals and MANUAL, for manual shifting. When not connecting a pedal, the OFF/EXT CONT position is for turning off the pitch shift.

• Pitch Slider 23

This slider is used for shifting the pitch manually. NORMAL is to your right-hand side.

• PITCH SET 21

This knob determines the pitch range where the shifting will occur. Select the pitch which starts the shift (for AUTO and PEDAL CONTROL) or the pitch which is produced when the PITCH slider is slid all the way to the left (for MANUAL) with this knob. The range of selection for the pitch is from more than one octave below the normal pitch.

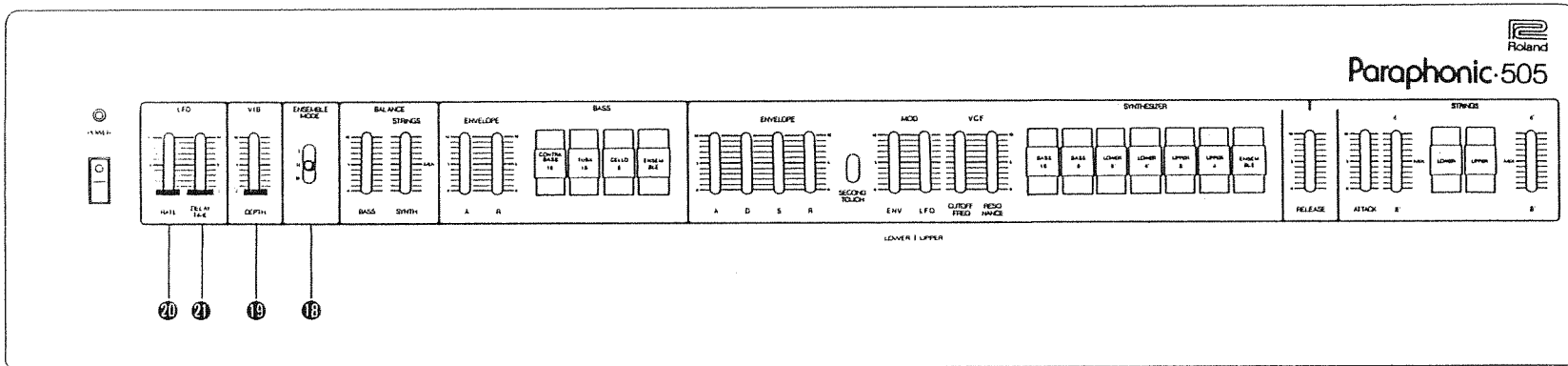

8 Ensemble Mode 11

Choose the ensemble effect from among the three:

- I...an ensemble sound with not much vibrato
- II...A dynamic strings sound
- III...a special sound with a revolving-effect.

9 Vibrato 11

This slider adjusts the depth of the vibrato. The more you slide it upward, the deeper it gets. Control the speed of the vibrato with LFO-RATE 20

10 LFO (Low Frequency Oscillator)

This output signal controls the VCO, and the VCA and produces the vibrato effect (changing the interval periodically) and the growl effect (changing the harmonic composition periodically).

• RATE 20

This slider produces variations in the speed (frequency) of the LFO. The speed increases as it is slid upward. This slider determines the speed of the vibrato and growl effects.

• DELAY TIME 21

With this slider, it is possible to lengthen the time interval from when a key is first pressed to the start of the vibrato or growl effect. The more you slide it upward, the longer the time becomes. This is used when you want to add the vibrato or growl effect for notes that are held for a certain time length.

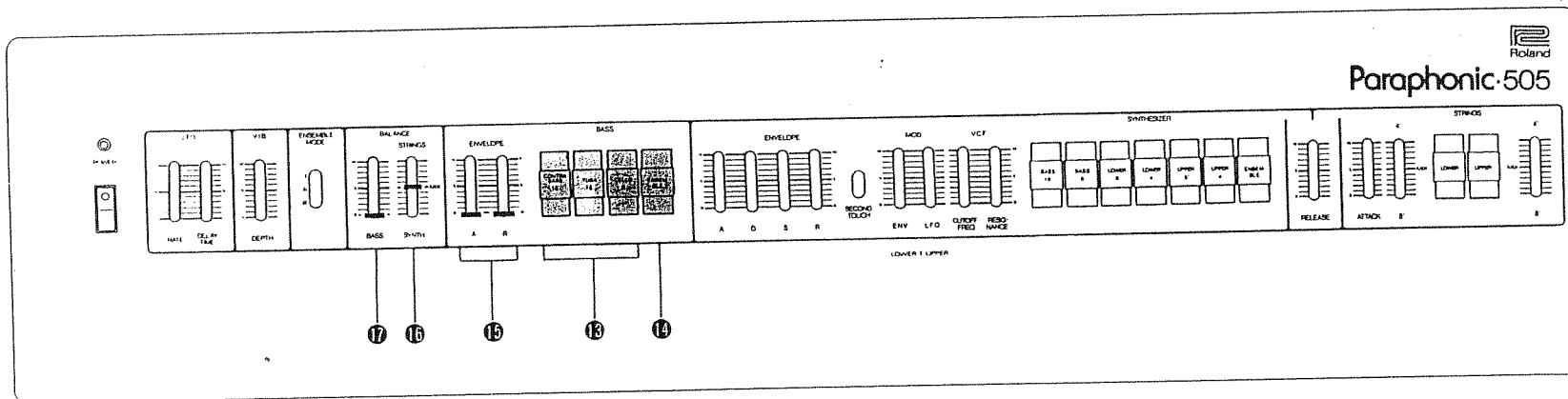

6 Bass Section

The BASS sound only functions in LOWER KEY. Since the lower note gets the priority, when two keys are played simultaneously, the lower note is the one that is produced.

- Tablet (maroon) 13

Choose the tone color of BASS. A combination of the two is also possible.

- Tablet (gray) 14

This tablet adds the ensemble effect to the BASS sound.

- ENVELOPE 15

A...This slider controls the ATTACK time of the BASS sound.

B...This slider controls the RELEASE time of the BASS sound.

* Just like ADSR in the Synthesizer Section, AR of the BASS section will not function unless a key is re-played.

7 Balance Control

- STRINGS-SYNTH 16

This slider controls the volume balance of the strings and the synthesizer. Moving the slider upward will strengthen the strings sound while moving it downward will strengthen the synthesizer sound.

- BASS 17

This slider controls the volume of the bass. The more you slide it upward the louder the volume becomes.

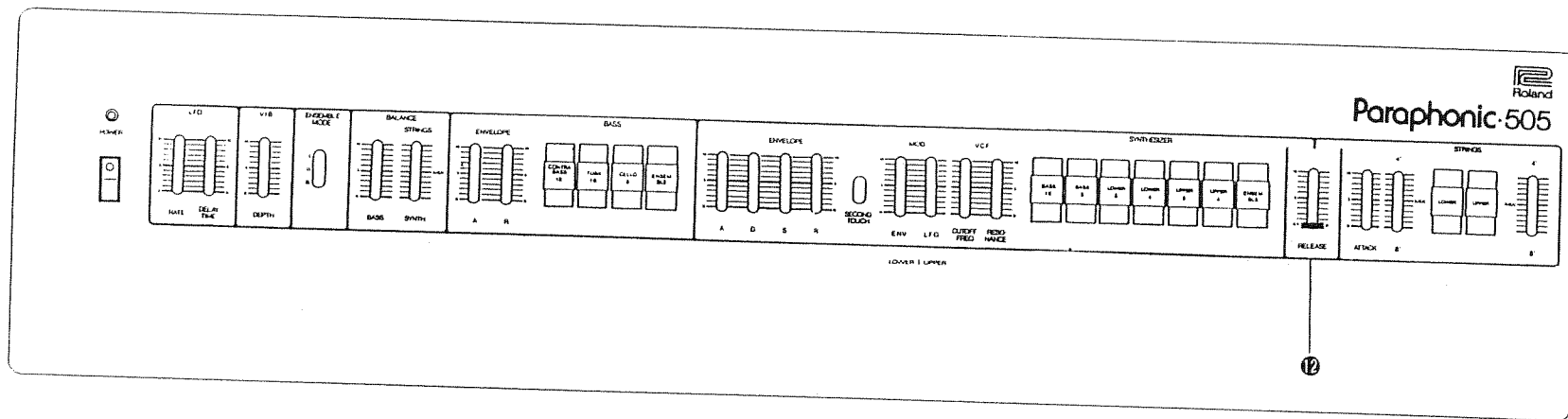

5 Release Control ⑩

This slider controls the time it takes for a sound to fade out after a key is released. The more you slide it upward the longer it takes for the sound to fade out. This slider is for both the strings section and the synthesizer section.

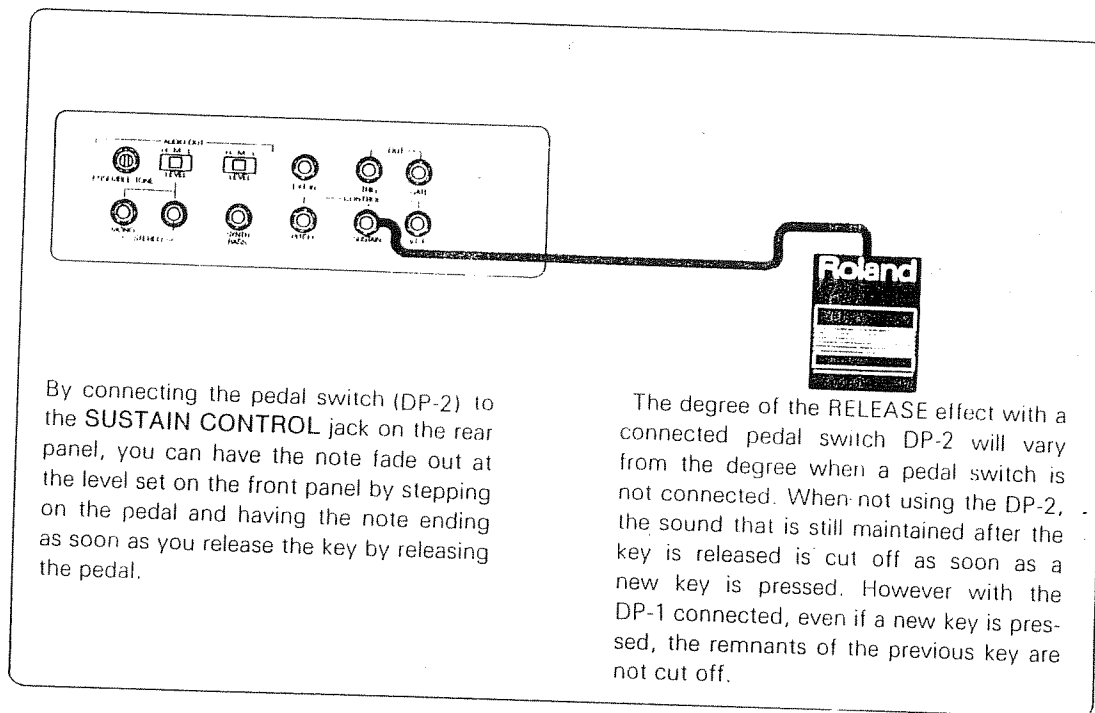

By connecting the pedal switch (DP-2) to the **SUSTAIN CONTROL** jack on the rear panel, you can have the note fade out at the level set on the front panel by stepping on the pedal and having the note ending as soon as you release the key by releasing the pedal.

The degree of the **RELEASE** effect with a connected pedal switch DP-2 will vary from the degree when a pedal switch is not connected. When not using the DP-2, the sound that is still maintained after the key is released is cut off as soon as a new key is pressed. However with the DP-1 connected, even if a new key is pressed, the remnants of the previous key are not cut off.

• ADSR Control of the VCA

You can control the volume of the VCA with the envelope signals (ADSR). With 505, ADSR and the VCA are internally connected. Therefore the switches and sliders other than the ones of ADSR need not be manipulated.

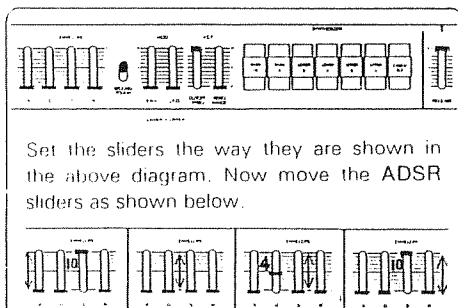

Set the sliders the way they are shown in the above diagram. Now move the ADSR sliders as shown below.

1 2 3 4

The effect of R is also in relation to the position of RELEASE, (found between the Synthesizer Section and the Strings Section).

• LFO Control of the VCF

You can control the VCF with the LFO signal, and obtain an effect similar to periodically working the wah-pedal (the growl effect). Adjust the degree of effect with the LFO slider (10). Control the speed of the effect with LFO-RATE (20).

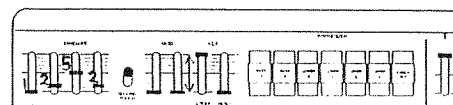

With the setup diagrammed above, move the LFO up and down and check the motion. Also, try moving the LFO-RATE slider.

• SECOND TOUCH ①

When this switch is OFF the envelope generator (ADSR) will function and control the VCF and the VCA, only when a key is re-pressed. When the switch is ON the envelope generator will function when a key is pressed, even when there is already a key that is still being pressed.

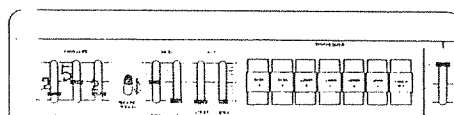

With the setup as diagrammed above, press key with your right hand and at the same time play the scale with your left hand. While paying close attention to the sound of the key that is being pressed by the right hand, switch on the SECOND TOUCH switch and follow the same procedure as previously mentioned.

• PEDAL Control of the VCF

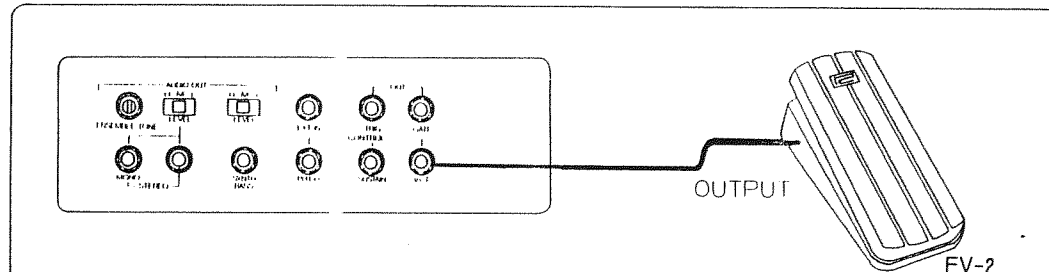

It is possible to move the cutoff frequency of the VCF with the pedal. In this case, set the CUTOFF FREQ and ENV sliders to 0.

It can be used like a wah-wah pedal by raising the resonance level.

• ADSR (The Envelope Generator) ⑧

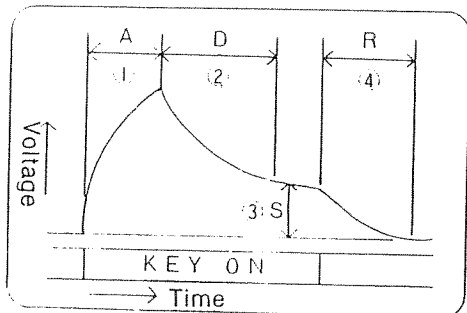

The envelope generator produces the control voltage that changes through time. It controls the VCF and the VCA and adds variations to the tone color and volume of each note through time lapse.

1 A (ATTACK TIME)

Adjust the ATTACK control to 0. The sound starts instantly. Adjust the ATTACK control to 10. In this case it takes time for the sound to reach full volume. This slider determines the time it takes for the voltage to reach its peak after a key is pressed.

2 D (DECAY TIME)

DECAY determines the time it takes for a sound to fade out. As shown in the diagram, it is the time when the voltage hits the peak and decreases to S (the SUSTAIN LEVEL). Therefore D and S are closely related. When S is raised there are no changes in the form of the envelope even with the D changing. Also when S is lowered, if you shorten D, a waveform appears only for an instant.

3 S (SUSTAIN LEVEL)

This slider determines the maintenance level after the envelope has reached its peak. When pressing a key, the note will be held at the level you assign here. It should be noted that ADR are all of time value whereas S is of a level value.

4 R (RELEASE TIME)

This slider determines the time it takes for a sound to end or fade out after the key is released.

*ADSR SETUPS AND ENVELOPE WAVEFORMS

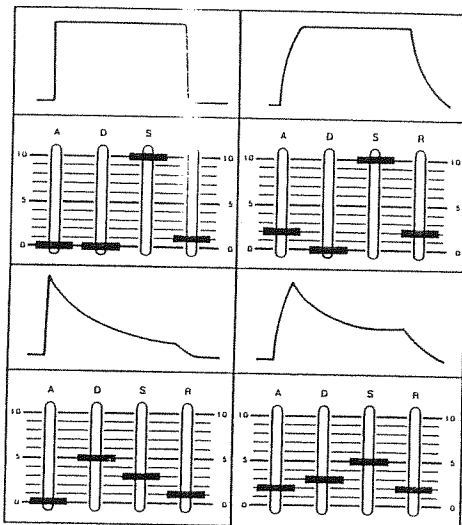

**If the ADSR sliders are all at 0, only a short pulse waveform will be generated, and only a clicking noise will be produced.

• ADSR Control of the VCF

You can control the VCF with ADSR. Adjust ENV ⑨ to see how much the envelope signal (ADSR) can change the cutoff frequency of the VCF. Raising this slider will make variations to the characteristics of the VCF, with the patterns of the ADSR set up in advance to each note that you play. The harmonic composition of each generated sound will change time-wise, according to the patterns. However, when CUTOFF FREQ is raised all the way, there will be no changes in the tone color.

With the setup diagrammed above, slide ENV upward and downward little by little while pressing and releasing a key slowly. Next set ENV to 0 and raise the CUTOFF FREQ slider little by little. Compare the effects of CUTOFF FREQ and ENV, paying attention to the difference in tone color. Raising RESONANCE will further intensify the difference.

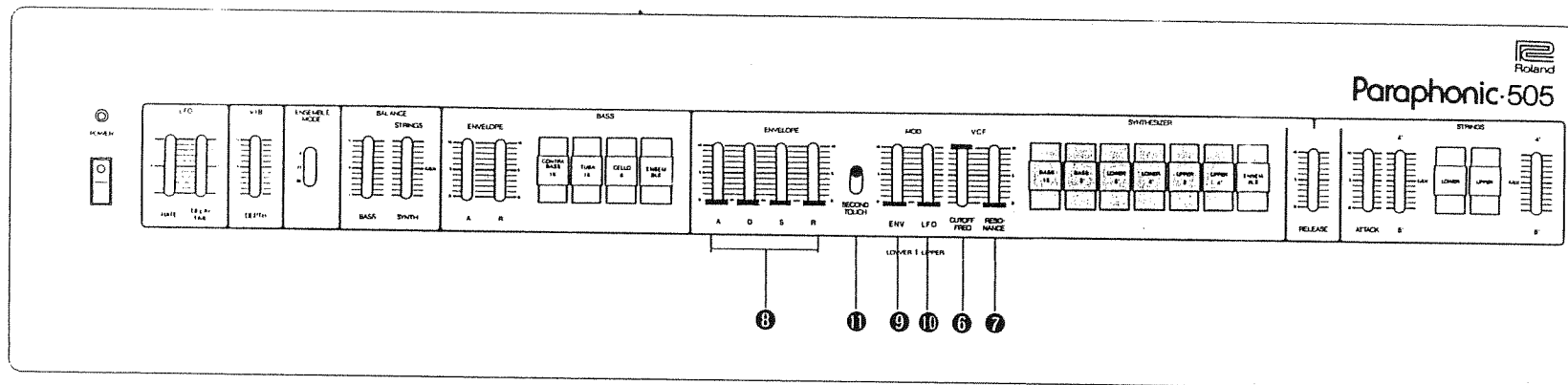

• **CUTOFF FREQ 6**

This slider determines which frequency to cut off. At maximum level, the waveforms generated are passed through. However as the level is lowered, the signals of the upper harmonics will be shaved off. With a setup as shown in the diagram above, move the **CUTOFF FREQ** slider while playing the keys and check the balance of the tone color and volume.

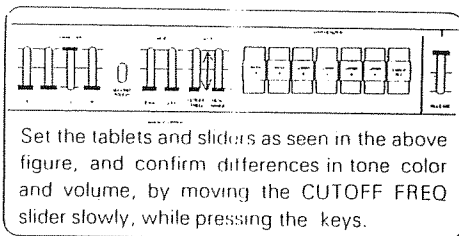

• **RESONANCE 7**

This slider controls the degree of resonance that accents the frequencies at the cutoff point. Moving the slider upward will emphasize certain harmonics. This makes the production of unique sounds possible. The manipulation of **RESONANCE** might produce changes in volume. Make necessary adjustments with either the **BALANCE CONTROL** or the **MASTER VOLUME**. With the setup shown in the diagram above, move the **RESONANCE** slider up and down. Next, set **RESONANCE** at 10 and slide up and down the **CUTOFF FREQ** slider.

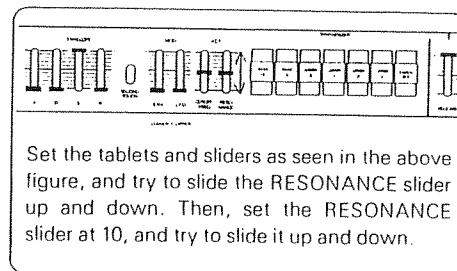

• **VCA (Voltage Controlled Amplifier)**

Although it is not indicated on the panel, 505 is internally equipped with a VCA. The VCA controls the volume.

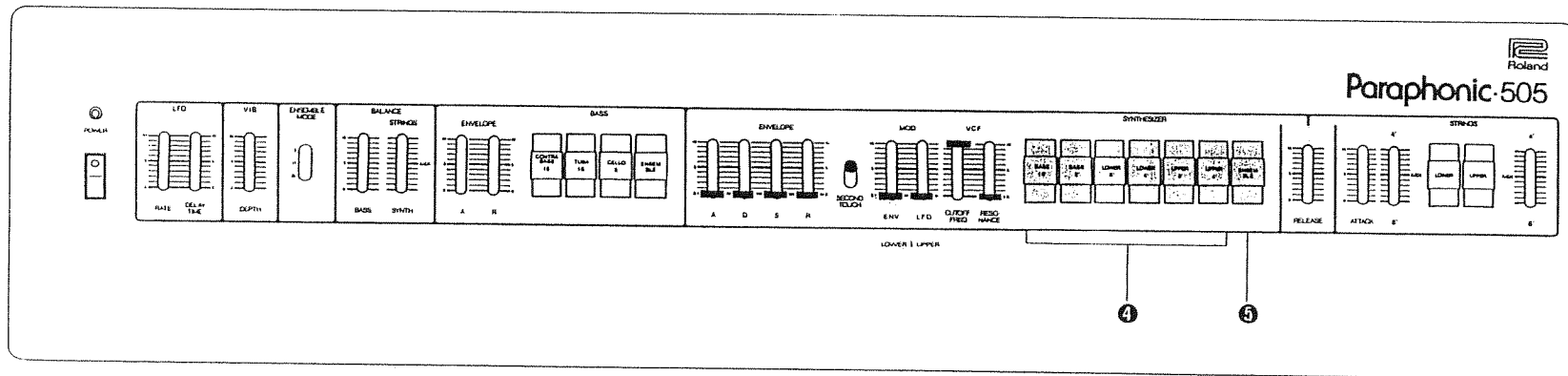

4] Synthesizer Section

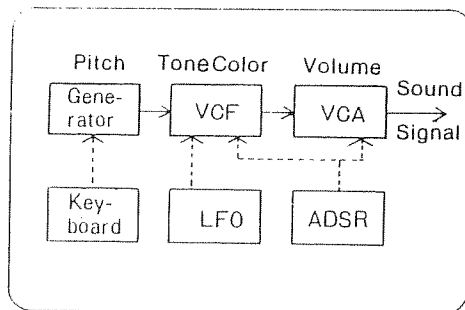

This is the block diagram of the synthesizer section of 505.

• Tablet (ivory, maroon) 4

Choose the sound source for the UPPER KEY and the LOWER KEY. Between 4' and 8' and 8' and 16', there will be a difference of one octave even if it is the same key.

*For UPPER KEY

UPPER 8', 4' (ivory)

*For LOWER KEY

LOWER 8', 4' (ivory)

BASS 8', 16' «priority on low notes»
(maroon)

• Tablet (gray) 5

This tablet adds the ensemble effect to the sound of the synthesizer section.

• VCF (Voltage Controlled Filter)

The VCF controls the tone color.

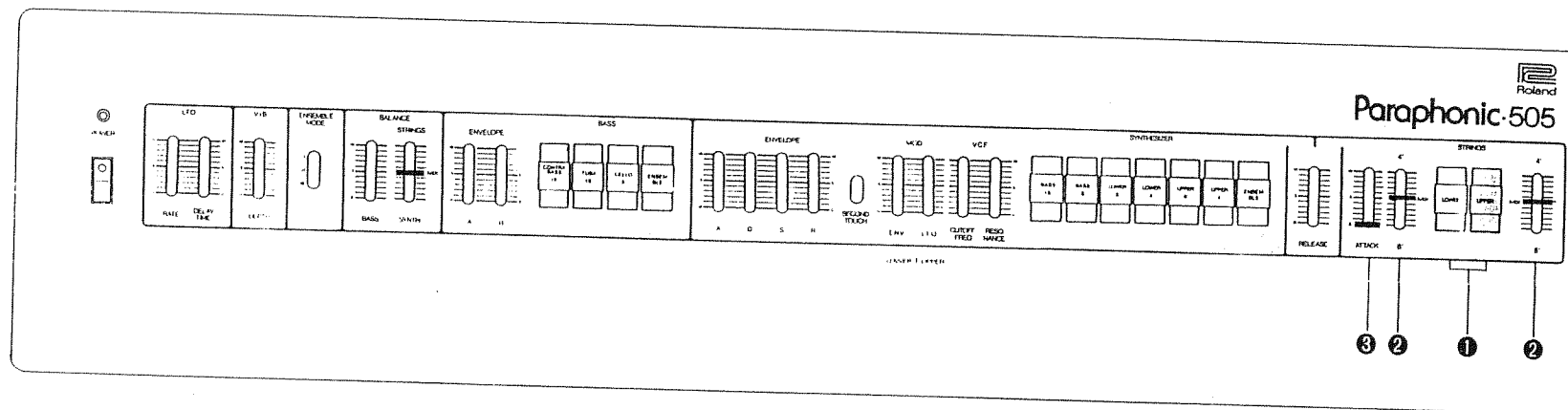

3] Strings Section

• Tablet (green) ①

These tablets are for turning on or off the strings sound. Use **UPPER** when producing the strings sound with the upper key and **LOWER** when producing the strings sound with the lower key. Press the tablet to turn it on.

• 4' — MIX — 8' ②

Slide it all the way up and you will get only the 4' sound. Slide it all the way down and you will get only the 8' sound. At medium level, you can adjust the ratio of the two sounds, according to what kind of effect you want to produce. The slider on the right-hand side of the **UPPER** tablet is for the **UPPER KEY**. The slider on the left hand side of the **LOWER** tablet is for the **LOWER KEY**.

• ATTACK ③

This slider controls the time it takes for the strings sound to be produced after a key is pressed. The more you slide it upward, the longer the time becomes.

ATTACK does not work unless a key is re-pressed. Therefore you will get the **ATTACK** effect on only the first note in legato performances.

• FUNCTIONS OF THE COMPONENTS

505 is basically made up of three parts; the strings section, the synthesizer section and the bass section. It is possible to either play them separately or simultaneously. Furthermore 505 is divided into UPPER KEY and LOWER KEY (the bass section is limited to LOWER KEY). Select the right key according to what you are playing and how you want it to sound.

[1] Power Switch

When you turn on the switch, the pilot lamp will light up and 505 is ready for operation.

[2] Keyboard

505 is in itself a 49-key, 4-octave keyboard. However with changes made on the tablets it will become a 7-octave keyboard, as diagrammed below. With middle C as the borderline, the key-

board can be divided into UPPER and LOWER. The UPPER and LOWER tablets will function as indicated. With the BASS tablets, only the LOWER tablet can be used.

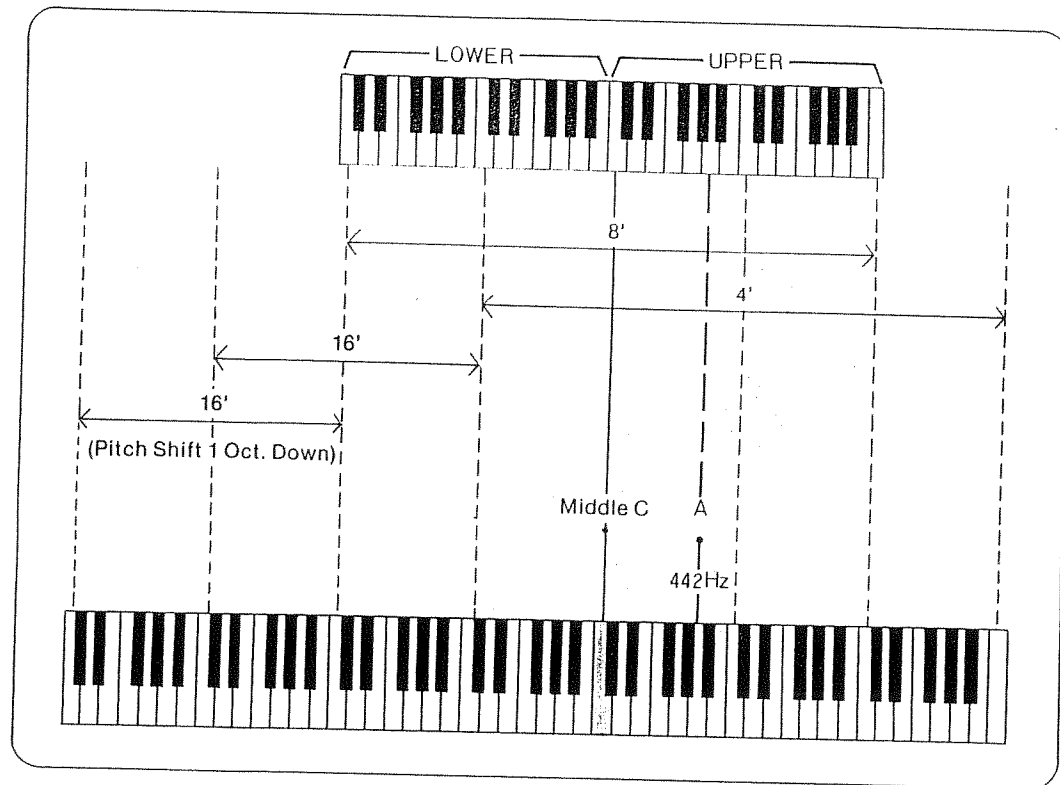

• NAMES OF THE COMPONENTS

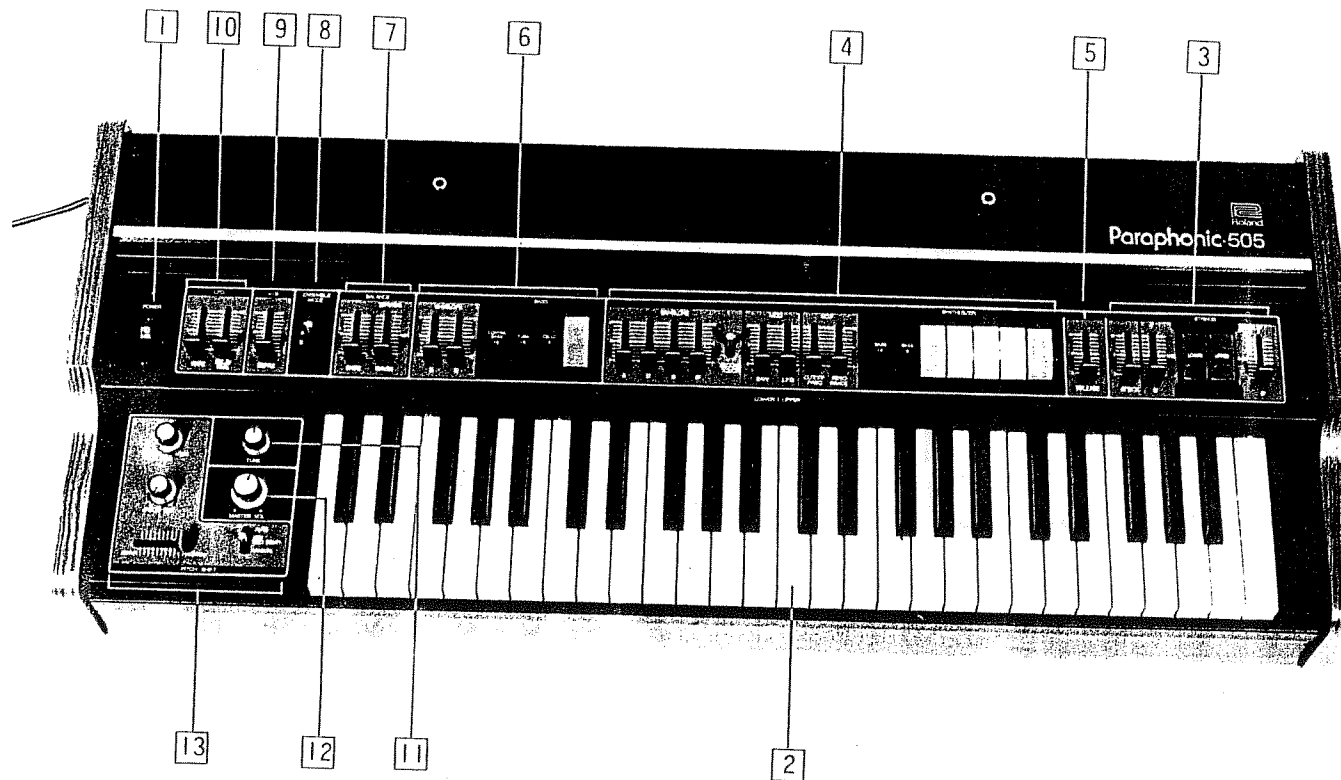

- 1 Power Switch
- 2 Keyboard
- 3 Strings Section
- 4 Synthesizer Section
- 5 Release Control

- 6 Bass Section
- 7 Balance Control
- 8 Ensemble Mode
- 9 Vibrato

- 10 LFO
- 11 Tuning
- 12 Master Volume
- 13 Pitch Shift

• Instructions for Hookup
AUDIO OUT

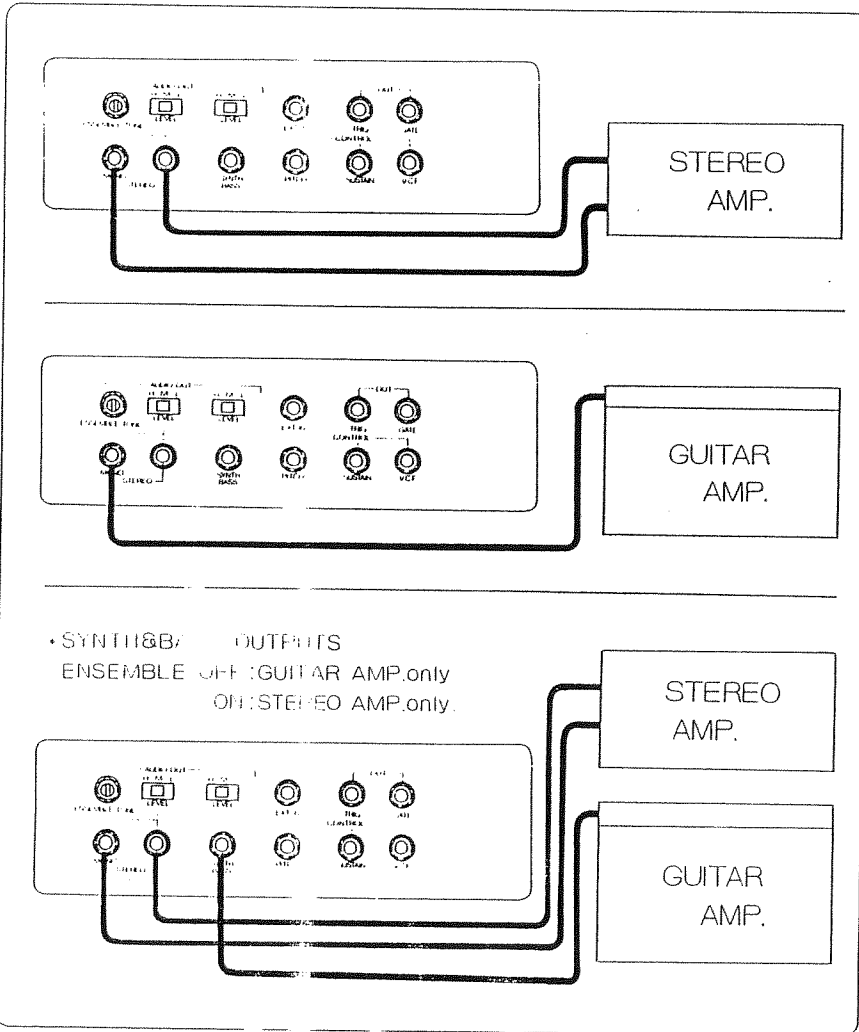

GATE/TRIG OUT

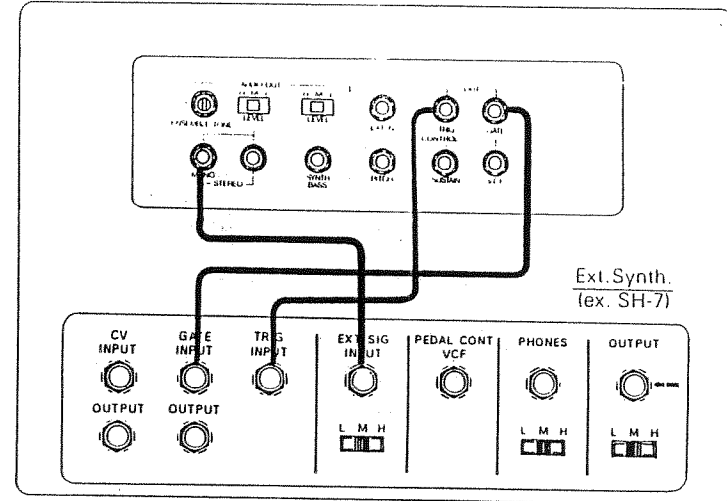

CONTROL

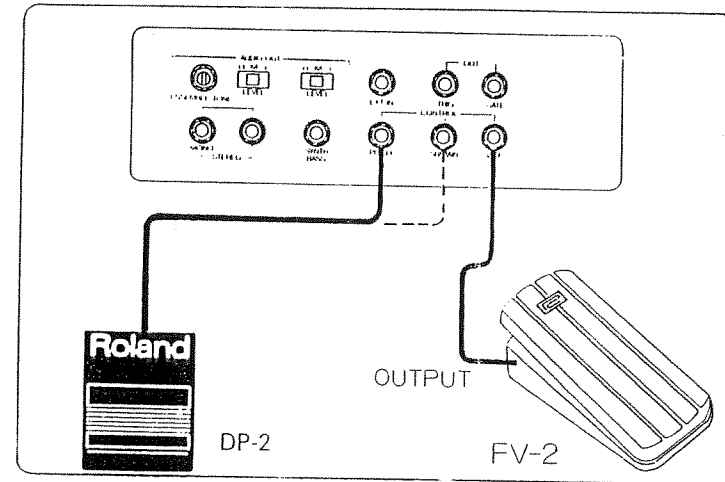

• HOOKUP

• CONNECTION JACKS

①②③ AUDIO OUT (Output Jacks)

These are the output jacks of 505. Choose the jack according to the kind of amplifier used, e.g., a guitar amplifier, mixer, or audio amplifier.

④⑤ AUDIO LEVEL (Output Level)

Choose from L, M or H according to the input sensitivity of the amplifier used.

AUDIO AMPLIFIER	H
GUITAR AMPLIFIER	L, M
PA, MIXER	H, M, L

⑥ ENSEMBLE TONE

This knob controls the tone quality of the ensemble. The further you turn it to the right, the stronger the emphasis becomes on the sound range of the high tones.

⑦ EXT IN (External Input Jack)

By connecting another instrument to this jack, you can add the ensemble effect to the sound of that instrument that was connected.

⑧⑨ TRIG/GATE OUT

These are the output jacks of the GATE signal and the TRIGGER signal which are

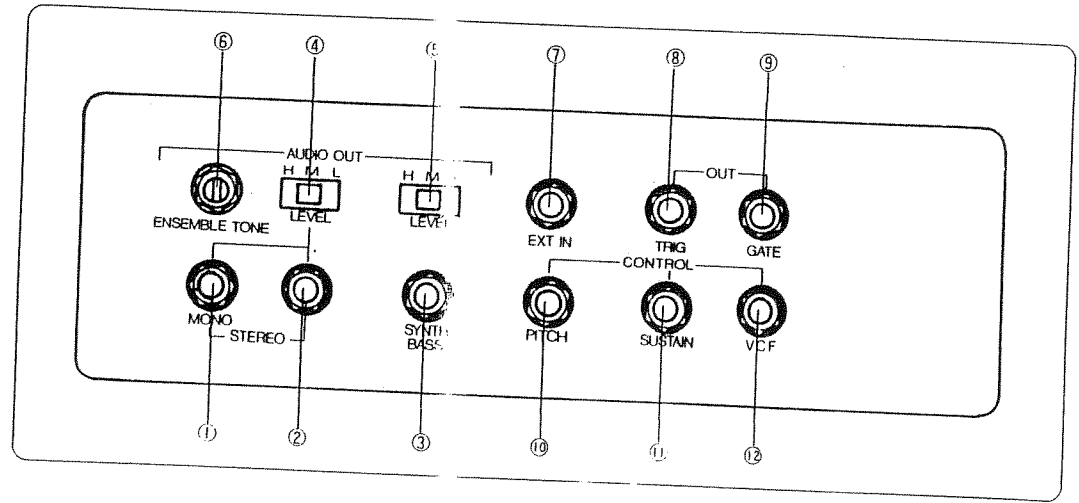

generated when a key is pressed. These jacks are used for connecting other synthesizers to 505 to produce further variations in sound.

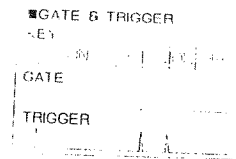

As seen in the above diagram the GATE signal is the voltage generated while a key is being pressed. The TRIGGER signal is the pulse-form voltage generated every time a new key is pressed. These signals make it possible to operate the envelope generator of other synthesizers.

⑩⑪⑫ CONTROL (External Control Connection Jacks)

Connecting the pedal switch (DP-2) or the foot volume (FV-2) to one of these jacks, the external control of the pitch shift, sustenance and the VCF are made possible.

Roland®

10398

UPC

10398

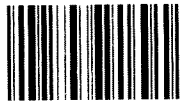

10398

«Before starting....»

- Power supply indicated on the name plate must be used. In case that the power supply in your district is different from it, it must be adjusted using the voltage regulator.
- This instrument is of A.C. power and might emit some heat. However this is not an indication of damage of any sort.
- Always plug the cord first before switching on the POWER SWITCH.

«PRECAUTIONS»

- Keep away from interferences that induce high level of noise such as fluorescent lamps, neon lights and transformers. Avoid places that are dusty, of high temperature or humidity.
- Clean the control panel with neutral detergent. Use a soft, dry cloth for the wooden body. Do not use solvents as paint thinner.

CONTENTS

•HOOKUP	4
•Connection Jacks	4
•Instructions for Hookup	5
•NAMES OF THE COMPONENTS	6
•Functions of the components	7
1 Power Switch	7
2 Keyboard	7
3 Strings Section	8
4 Synthesizer Section	9
5 Release Control	13
6 Bass Section	14
7 Balance Control	14
8 Ensemble Mode	15
9 Vibrato	15
10 LFO	15
11 Tuning	16
12 Master Volume	16
13 Pitch Shift	16
•SAMPLE SOUNDS	18
•SAMPLE NOTES	24
•BLOCK DIAGRAM	29
•SPECIFICATIONS	30