

DIGITAL DELAY SDE-1000

OWNER'S MANUAL



The Roland Rack

Features

The Roland Digital Delay SDE-1000 is a high quality delay machine with various attractive features.

- Wide Frequency Characteristic, Low Harmonic Distortion and Low Noise.
- Long Delay Time (Max. 1125ms).
- Highly Accurate Delay Time Display (0.1ms step indication from 0 to 10ms).
- Memory function retaining up to four different panel settings.
- Modulation Foot Control and Preset Shift Jacks useful for live performance.
- Play Mate Jack that enables delay time setting with the Foot Control.
- The Hold Jack that allows delay sound repetition.
- Delay Remote Jack that is useful for turning the Delay effect on or off.
- The twin Output Jacks useful for stereo performance such as chorus effect.

Contents

Panel Descriptions.....	4
Memory Function.....	8
Setting up.....	9
Sample Sounds.....	10
Original Memo.....	11
Block Diagram.....	13
Frequency Characteristic.....	14
Specifications.....	15

Important notes

- Be sure to use the voltage shown on the Name Plate on the rear panel.
- The SDE-1000 may generate heat during operation, this is quite a normal situation caused by AC power, so there is nothing to worry about it.
- Please never disassemble the SDE-1000 even if it breaks down.
- If the SDE-1000 is not to be used for a long period of time, unplug the cord from the socket.
- Please do not pull the cord but hold the plug when unplugging.
- Please avoid placing or dropping anything heavy on the Power Cable.
- Operating the SDE-1000 near a neon or fluorescent lamp may cause noise interference. If so, change the angle of the SDE-1000.
- Avoid using the SDE-1000 in extreme heat, humidity or where it may be affected by dust.

Panel Descriptions

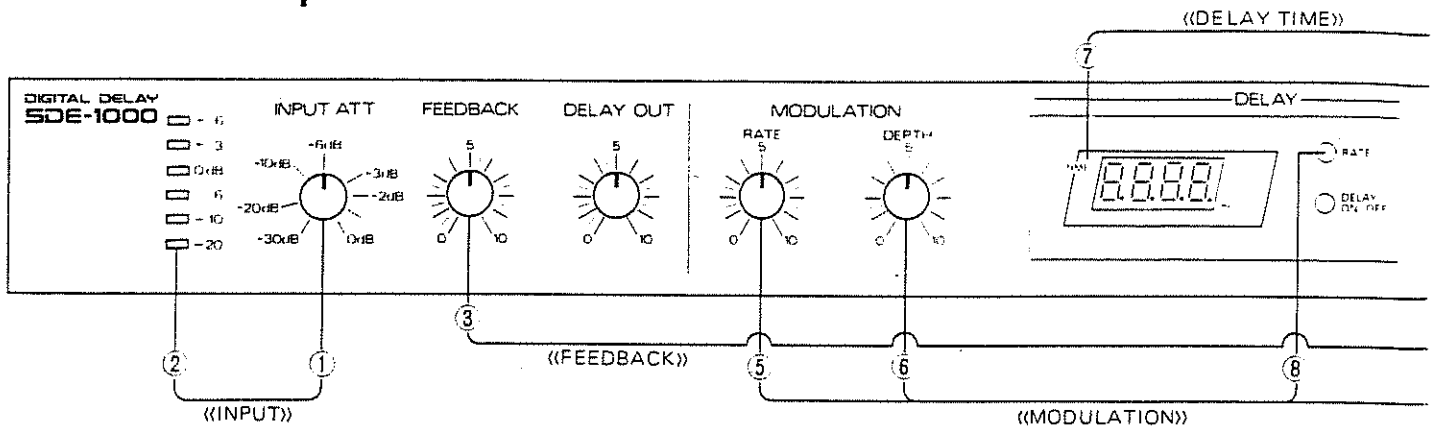

«INPUT ATT»

① INPUT Attenuator

When this knob is set to 0dB, the output level is equal to the input level. Set this knob to appropriate level where the Input Level Indicator +6dB lights up at its peak. (Distortion will start at +12dB.) Even this knob is turned fully counter-clockwise, the input level will not be zero.

② Input Level Indicators

*When the Input/Output Level Selector Switch (26) is set to the -20dBm position (-35dBm) and the Input Attenuator is set to 0dB, feeding -20dBm (-35dBm) signal will light up the 0B Indicator.

«FEEDBACK»

③ FEEDBACK Level Knob

⑮ FEEDBACK Switch with Feedback Indicator

Turn the Feedback Switch (15) on (the Indicator lights up), then adjust the Feedback level of the delay signal by using the Feedback Level Knob.

*If this knob is set to higher than 8, the SDE-1000 may oscillate.

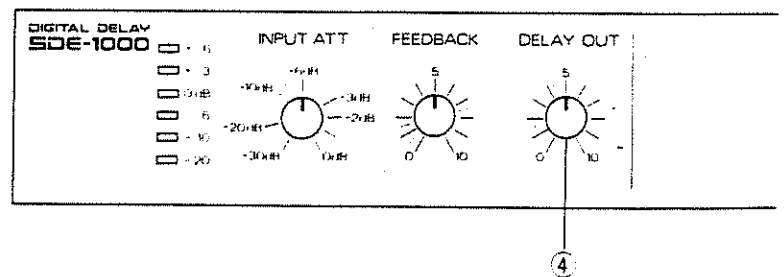

④ DELAY Output Knob

This sets the volume of the delay sound.

*At 5 position, the Gain is UNITY (Output level: Input level = 1:1).

*This knob has no effect on the direct sound.

⑨ DELAY ON/OFF Indicator

This lights up when the delay effect is turned on with the Foot Control.



*This indicator goes on or out just by Foot Control operation. Even if the DELAY Output Knob is set to zero, the indicator does not go out.

«Note»

The SDE-1000 features battery back up system to retain the memory even when switched off. The batteries should be replaced with a new set in every five years. In this case, please have your local Roland dealer do the job. (The first replacement might be required before five years.)

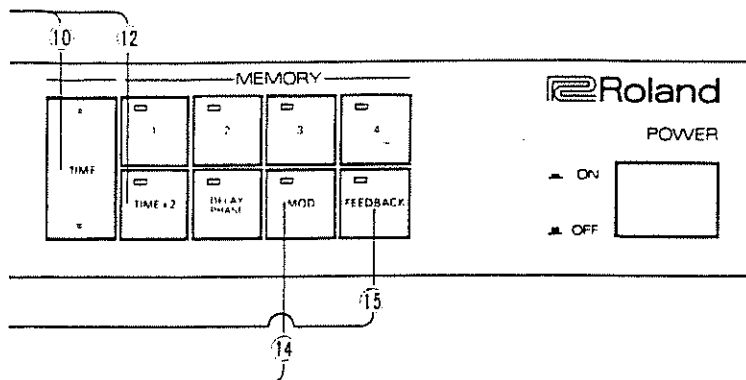

«MODULATION»

- ⑤ MODULATION RATE Knob
This sets the rate of the LFO Modulation.
- ⑥ MODULATION DEPTH Knob
- ⑧ Modulation Rate Indicator
- ⑭ MODULATION Switch with Modulation Indicator
Set the MODULATION Switch ⑭ ON (the Indicator lights up), then adjust the Rate and Depth by using the corresponding knobs ⑤ and ⑥. The Modulation Rate Indicator ⑧ flashes at the same rate as the LFO Frequency set with the MODULATION RATE Knob ⑤.

*The Modulation Rate Indicator ⑧ remains flashing whether the MODULATION Switch ⑭ is on or off.

«DELAY TIME»

- ⑦ DELAY TIME Display
- ⑩ DELAY TIME Button
- ⑫ Delay Range Switch with Delay Range Indicator
Select the delay range with the Delay Range Switch ⑫ (when "x 2" position is selected, the indicator lights up), then set the delay time with the DELAY TIME Button ⑩. The current delay time is shown in the DELAY TIME Display ⑦.

*The DELAY TIME Button is used to set the Delay Time. Pressing the upper part ▲ will advance the figure on the Display, making the Delay Time longer, and pressing ▼ side will shorten it. Pressing one side while holding the other side down will quicken this change.

	Delay Time	Frequency Characteristic
OFF (x 1)	0 to 375ms	10 to 17kHz (+0.5dB)
ON (x 2)	0 to 750ms	10 to 8 kHz (+0.5dB)

*The Delay Time shown in the Display Window may slightly alter after a while. Even so, there is nothing to worry about it, simply adjust it right.

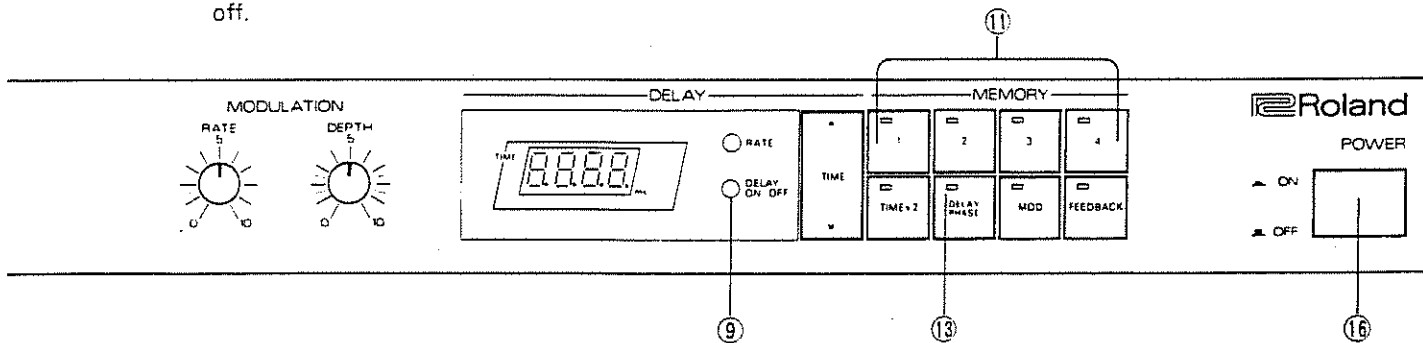

- ⑪ Memory Channel Selector Switches with Memory Channel Indicators
Four different panel settings can be written into Memory. You can select any of the four Channels just by pressing the switch. Delay Time, as well as whether the Delay Range, DELAY PHASE, Modulation and FEEDBACK Switches are on or off are included in the panel setting to be written into memory.
- *Simply keep pressing a relevant Channel Switch for about two seconds, and the Indicator of that Channel Switch will flash showing that writing is completed. If you just touch the switch, the existing panel setting will be recalled.

- ⑬ DELAY PHASE Switch with Delay Phase Indicator
With this switch, the Phase of the delay sound can be inverted.
- ⑯ POWER Switch
*The SDE-1000 remains muted for about seven seconds even after turned on. Neither the direct or delay sound is output. The panel setting remains as it is even if the SDE-1000 is turned off. (Refer to P.7)

⑰ Earth

*Ground wire installation is necessary for safety.

⑱ DELAY TIME Expanding Knob

With this knob, Delay Time can be increased up to 1.5 times (Normally, this should be set to "x 1").

* If you use the instrument other than electric guitar or bass, a beat may be caused. If so, rotate the DELAY TIME Expanding Knob counterclockwise until the beat stops.

* If the Feedback Level is high, the SDE-1000 may start oscillating at a high pitch. (If so, reduce the level or rotate the DELAY TIME Expanding knob counterclockwise until the oscillation stops.)

* When writing a panel setting or recalling it, set this switch to the same level.

* If setting such a long delay that is impossible to set in the "x 1" mode, the delay time later in use in the "x 1" mode will not be longer than the maximum delay time of the "x 1" mode.

* When the Modulation Switch is set to on, rotating the Delay Time Expanding Knob does not affect the Delay Time Display.

* To see the current delay time, simply set the Modulation Switch to the OFF position once.

⑲ MODULATION FOOT CONTROL Jack

By connecting the Foot Control such as FV-200 to this jack, delay time can be controlled with the foot pedal. Be sure to turn the Modulation Switch ⑭ on, before starting control. The depth of the modulation can be controlled with the MODULATION DEPTH Knob ⑥

⑳ Preset Shift Jack

By connecting the Pedal Switch (DP-2) to this jack, four preset panel settings can be sequentially called.

㉑ PLAY MATE Jack

This is to connect to the Pedal Switch (DP-2). You can set a Delay Time of any length just by pressing the Pedal. The following shows the way to do that.

1. Connect the DP-2 to the PLAY MATE Jack.
2. Press the pedal, and the Delay Time Display will show "0.0.0.0." (Stand-by mode), and the Delay Time Indicator remains dark (the Delay effect is off).
3. Press the DP-2 twice, and the built-in computer sets the Delay Time according to the interval between the first pressing and the second.
4. If you press the Pedal once again, the DELAY TIME Display shows "0.0.0.0." and the SDE-1000 is in the Stand-by mode again.

* Please do not touch the MODULATION Switch or DELAY TIME Expanding Knob during above procedures. Otherwise the accurate delay time may not be obtained.

* The longest Delay Time you can set in the SDE-1000 is 750ms, so if you happen to set the Delay Time exceeding 750ms, the DELAY TIME Display flashes showing the maximum Delay Time (750). In such a case, press the DP-2 and set the Delay Time again.

㉒ HOLD Remote Jack

You can turn the Delay Hold function on or off by connecting the Pedal Switch DP-2 to this jack. While the Pedal is depressed, the sound will be repeated.

* This effect cannot be obtained if the delay time is shorter than 20ms. When this function is being used, the Memory Channel Selector ⑪, the Delay Time Button ⑩ or Preset Shift Jack ⑳ do not work.

* If you touch the Delay Time Button ⑩ while this Hold function is on, the delay sound may be muted.

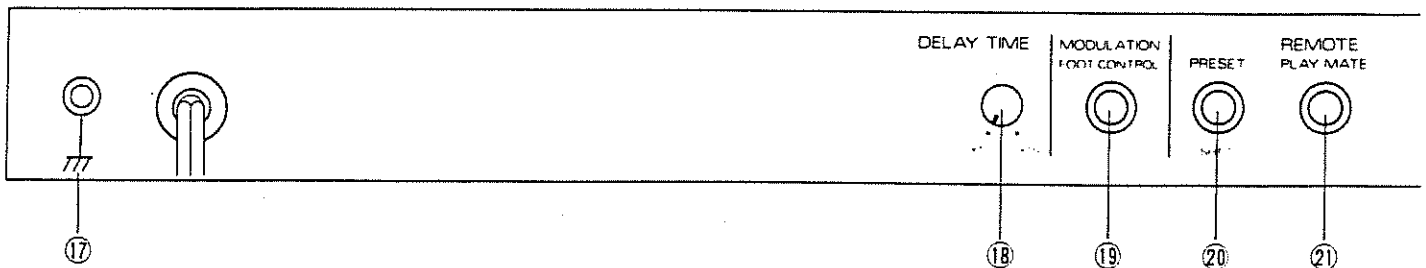

23 DELAY Remote Jack

By connecting the Foot Control such as FS-1 or DP-2, the delay effect can be turned on or off with the pedal.

* Pressing the DP-2 turns the delay effect on and releasing it turns it off.

24 DELAY OUTPUT Jack

25 MIXED OUTPUT Jack

- ▶ If only the DELAY OUTPUT Jack 24 is used, only the delay signal comes out.
- ▶ If only the MIXED OUTPUT Jack 25 is used, both the direct and delay signals come out.
- ▶ If both jacks are used, direct signal comes out from the MIXED OUTPUT Jack 25 and delay signal from the DELAY OUTPUT Jack 24.

26 Input/Output Level Selector Switch

Set this switch to -20dBm or -35dBm depending on the instrument or equipment you use.

* Please be sure to select the proper position to obtain the best possible delay effect.

The following is rough category for setting this switch.

- -20dBm Electronic Musical Instruments such as a synthesizer or ordinary Audio Equipment, electric guitar, electric bass guitar (high gain) etc.
- -35dBm Devices with high output impedance such as an electric guitar, electric bass guitar (low gain), etc.

27 INPUT Jack

* For feeding low level input such as guitar or microphone, a preamp or microphone amplifier may be needed.

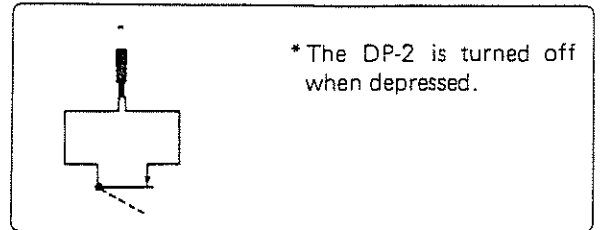
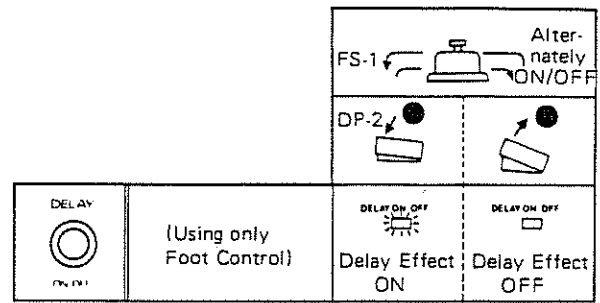
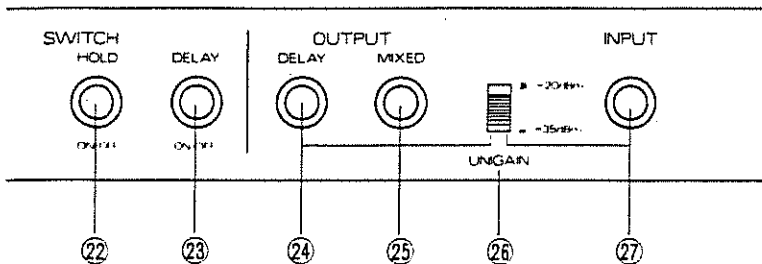

(Notes)

In the following cases, delay sound is completely muted, therefore, only the direct sound is heard.

1. When you change the delay time;
The delay sound is muted as long as the DELAY TIME Button is depressed, and still muted even after the button is released until the SDE-1000 get the stand-by mode.
* Here, the DELAY TIME Indicator does not light.
2. When recalling from Memory;
The delay sound is muted as long as the Delay Time shown on the Display.
3. When the DELAY RANGE Switch is set to the "x 2" position;
The delay sound is muted as long as the delay time of the "x 1" mode.

Memory Function

How to write the panel setting into memory

1. Set the Panel to your taste.

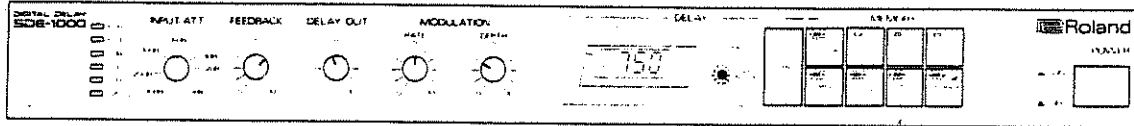

2. Press any one of the four Channels for about two seconds.

© If you release the switch quickly, the existing panel setting in memory will be recalled.

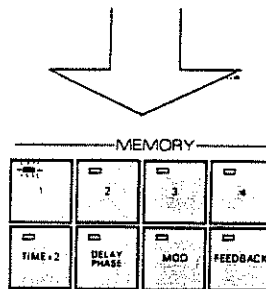

3. If the writing has been completed, the Memory Channel Indicator will flash.

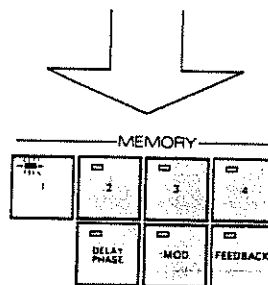

© Included in the panel setting to be written into memory are Delay Time, and whether the Delay Range, DELAY PHASE, MODULATION and FEEDBACK Switches are on or off.

Setting up

• INPUT, OUTPUT

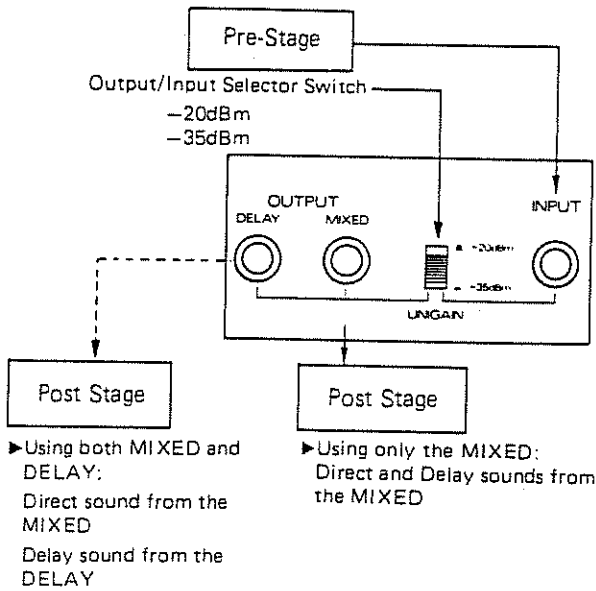

* The SDE-1000 can select rated input levels between -20dBm and -35dBm , i.e. it is designed to have UNITY Gain (Input level: Output level = 1:1). Therefore, the SDE-1000 should be set up between two devices whose rated input levels are equally -20dBm or -35dBm . There should be no level difference between the two units connected to the SDE-1000.

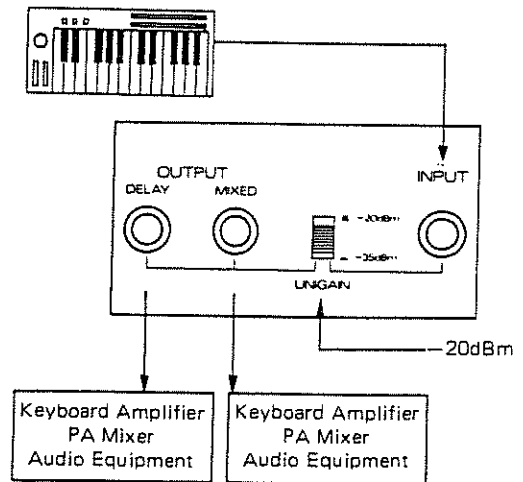
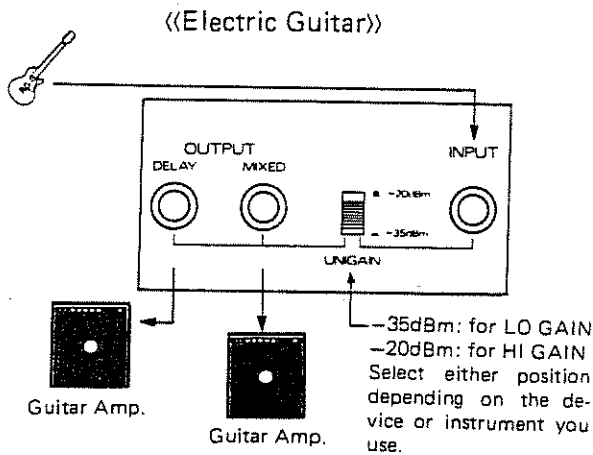

* Most of the electric guitars can be directly connected.

• MODULATION FOOT CONTROL

«PA Mixer»

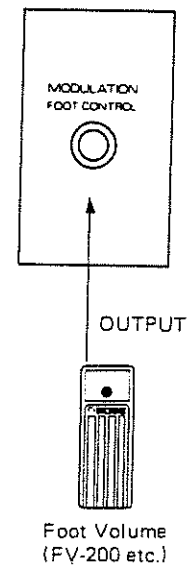
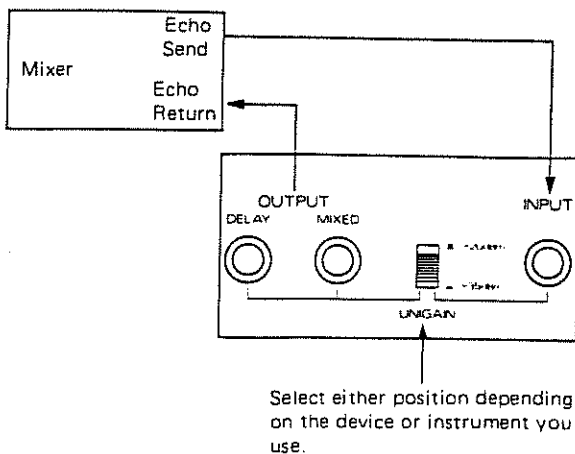

Sample Sounds

The panel settings 1 to 4 are pre-programmed in Memory from the manufacturer.

1. Long Delay

DIGITAL DELAY SDE-1000

MEMORY: 1, 2, 3, 4, 5, 6, 7, 8, 9, 10, 11, 12, 13, 14, 15, 16, 17, 18, 19, 20

DELAY: OFF ON

MODULATION: RATE 5, DEPTH 5

DELAY OUT: 5

FEEDBACK: 5

INPUT ATT: 0

POWER: ON OFF

2. Doubler

DIGITAL DELAY SDE-1000

MEMORY: 1, 2, 3, 4, 5, 6, 7, 8, 9, 10, 11, 12, 13, 14, 15, 16, 17, 18, 19, 20

DELAY: OFF ON

MODULATION: RATE 5, DEPTH 5

DELAY OUT: 5

FEEDBACK: 5

INPUT ATT: 0

POWER: ON OFF

3. Chorus

DIGITAL DELAY SDE-1000

MEMORY: 1, 2, 3, 4, 5, 6, 7, 8, 9, 10, 11, 12, 13, 14, 15, 16, 17, 18, 19, 20

DELAY: OFF ON

MODULATION: RATE 5, DEPTH 5

DELAY OUT: 5

FEEDBACK: 5

INPUT ATT: 0

POWER: ON OFF

4. Flanger

DIGITAL DELAY SDE-1000

MEMORY: 1, 2, 3, 4, 5, 6, 7, 8, 9, 10, 11, 12, 13, 14, 15, 16, 17, 18, 19, 20

DELAY: OFF ON

MODULATION: RATE 5, DEPTH 5

DELAY OUT: 5

FEEDBACK: 5

INPUT ATT: 0

POWER: ON OFF

Original Memo

DIGITAL DELAY SDE-1000

INPUT ATT: 0, 1, 2, 3, 4, 5, 6, 7, 8, 9, 10, 11, 12, 13, 14, 15, 16, 17, 18, 19, 20, 21

FEEDBACK: 0, 1, 2, 3, 4, 5, 6, 7, 8, 9, 10, 11, 12, 13, 14, 15, 16, 17, 18, 19, 20, 21

DELAY OUT: 0, 1, 2, 3, 4, 5, 6, 7, 8, 9, 10, 11, 12, 13, 14, 15, 16, 17, 18, 19, 20, 21

MODULATION RATE: 0, 1, 2, 3, 4, 5, 6, 7, 8, 9, 10, 11, 12, 13, 14, 15, 16, 17, 18, 19, 20, 21

MODULATION DEPTH: 0, 1, 2, 3, 4, 5, 6, 7, 8, 9, 10, 11, 12, 13, 14, 15, 16, 17, 18, 19, 20, 21

DELAY: RATE DELAY

MEMORY: 0, 1, 2, 3, 4, 5, 6, 7, 8, 9, 10, 11, 12, 13, 14, 15, 16, 17, 18, 19, 20, 21

Roland POWER: OFF ON

DIGITAL DELAY SDE-1000

INPUT ATT: 0, 1, 2, 3, 4, 5, 6, 7, 8, 9, 10, 11, 12, 13, 14, 15, 16, 17, 18, 19, 20, 21

FEEDBACK: 0, 1, 2, 3, 4, 5, 6, 7, 8, 9, 10, 11, 12, 13, 14, 15, 16, 17, 18, 19, 20, 21

DELAY OUT: 0, 1, 2, 3, 4, 5, 6, 7, 8, 9, 10, 11, 12, 13, 14, 15, 16, 17, 18, 19, 20, 21

MODULATION RATE: 0, 1, 2, 3, 4, 5, 6, 7, 8, 9, 10, 11, 12, 13, 14, 15, 16, 17, 18, 19, 20, 21

MODULATION DEPTH: 0, 1, 2, 3, 4, 5, 6, 7, 8, 9, 10, 11, 12, 13, 14, 15, 16, 17, 18, 19, 20, 21

DELAY: RATE DELAY

MEMORY: 0, 1, 2, 3, 4, 5, 6, 7, 8, 9, 10, 11, 12, 13, 14, 15, 16, 17, 18, 19, 20, 21

Roland POWER: OFF ON

DIGITAL DELAY SDE-1000

INPUT ATT: 0, 1, 2, 3, 4, 5, 6, 7, 8, 9, 10, 11, 12, 13, 14, 15, 16, 17, 18, 19, 20, 21

FEEDBACK: 0, 1, 2, 3, 4, 5, 6, 7, 8, 9, 10, 11, 12, 13, 14, 15, 16, 17, 18, 19, 20, 21

DELAY OUT: 0, 1, 2, 3, 4, 5, 6, 7, 8, 9, 10, 11, 12, 13, 14, 15, 16, 17, 18, 19, 20, 21

MODULATION RATE: 0, 1, 2, 3, 4, 5, 6, 7, 8, 9, 10, 11, 12, 13, 14, 15, 16, 17, 18, 19, 20, 21

MODULATION DEPTH: 0, 1, 2, 3, 4, 5, 6, 7, 8, 9, 10, 11, 12, 13, 14, 15, 16, 17, 18, 19, 20, 21

DELAY: RATE DELAY

MEMORY: 0, 1, 2, 3, 4, 5, 6, 7, 8, 9, 10, 11, 12, 13, 14, 15, 16, 17, 18, 19, 20, 21

Roland POWER: OFF ON

DIGITAL DELAY SDE-1000

INPUT ATT: 0, 1, 2, 3, 4, 5, 6, 7, 8, 9, 10, 11, 12, 13, 14, 15, 16, 17, 18, 19, 20, 21

FEEDBACK: 0, 1, 2, 3, 4, 5, 6, 7, 8, 9, 10, 11, 12, 13, 14, 15, 16, 17, 18, 19, 20, 21

DELAY OUT: 0, 1, 2, 3, 4, 5, 6, 7, 8, 9, 10, 11, 12, 13, 14, 15, 16, 17, 18, 19, 20, 21

MODULATION RATE: 0, 1, 2, 3, 4, 5, 6, 7, 8, 9, 10, 11, 12, 13, 14, 15, 16, 17, 18, 19, 20, 21

MODULATION DEPTH: 0, 1, 2, 3, 4, 5, 6, 7, 8, 9, 10, 11, 12, 13, 14, 15, 16, 17, 18, 19, 20, 21

DELAY: RATE DELAY

MEMORY: 0, 1, 2, 3, 4, 5, 6, 7, 8, 9, 10, 11, 12, 13, 14, 15, 16, 17, 18, 19, 20, 21

Roland POWER: OFF ON

DIGITAL DELAY SDE-1000

0 1 2 3 4
 5 6 7 8 9
 10 11 12 13 14
 15 16 17 18 19

INPUT ATT FEEDBACK DELAY OUT MODULATION RATE MODULATION DEPTH

RATE RATE
 DELAY IN DELAY IN

DELAY MEMORY

1 2 3 4
 5 6 7 8
 9 10 11 12

POWER ON OFF

DIGITAL DELAY SDE-1000

0 1 2 3 4
 5 6 7 8 9
 10 11 12 13 14
 15 16 17 18 19

INPUT ATT FEEDBACK DELAY OUT MODULATION RATE MODULATION DEPTH

RATE RATE
 DELAY IN DELAY IN

DELAY MEMORY

1 2 3 4
 5 6 7 8
 9 10 11 12

POWER ON OFF

DIGITAL DELAY SDE-1000

0 1 2 3 4
 5 6 7 8 9
 10 11 12 13 14
 15 16 17 18 19

INPUT ATT FEEDBACK DELAY OUT MODULATION RATE MODULATION DEPTH

RATE RATE
 DELAY IN DELAY IN

DELAY MEMORY

1 2 3 4
 5 6 7 8
 9 10 11 12

POWER ON OFF

DIGITAL DELAY SDE-1000

0 1 2 3 4
 5 6 7 8 9
 10 11 12 13 14
 15 16 17 18 19

INPUT ATT FEEDBACK DELAY OUT MODULATION RATE MODULATION DEPTH

RATE RATE
 DELAY IN DELAY IN

DELAY MEMORY

1 2 3 4
 5 6 7 8
 9 10 11 12

POWER ON OFF

Block Diagram

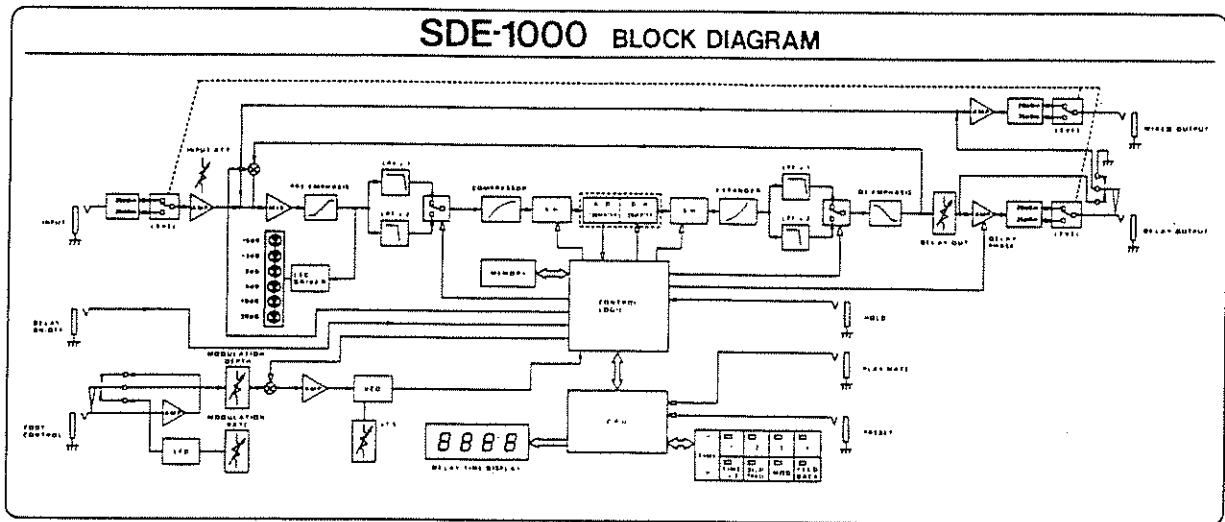

Fixing to the 19" Rack
Use 5mm screws.

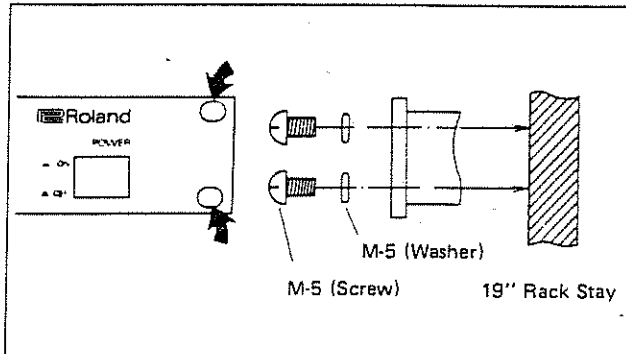

Frequency Characteristic

DELAY RANGE x 1

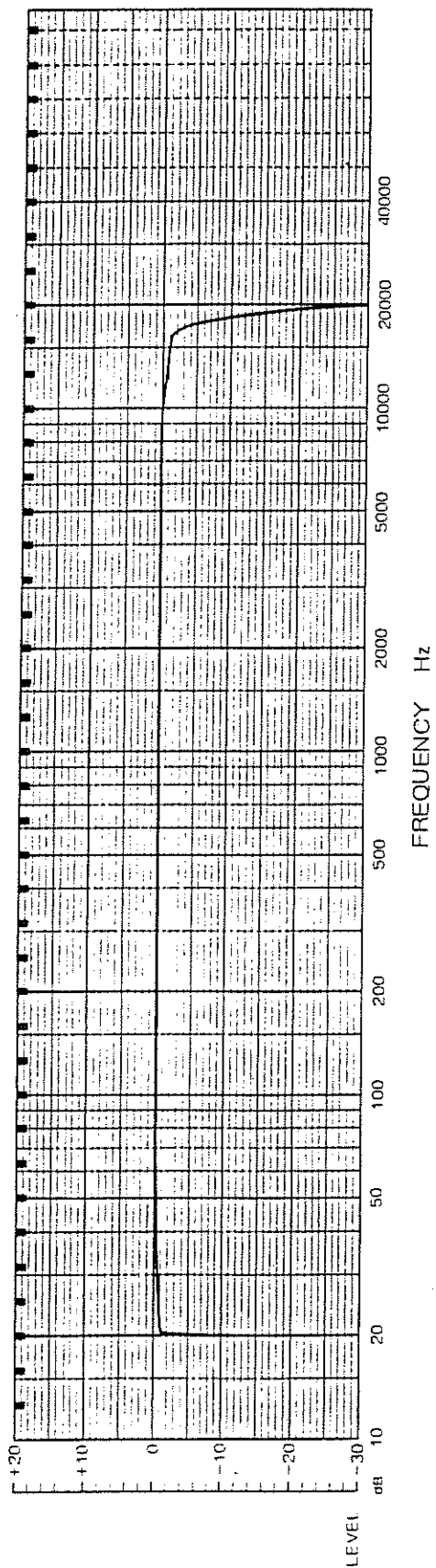

DELAY RANGE x 2

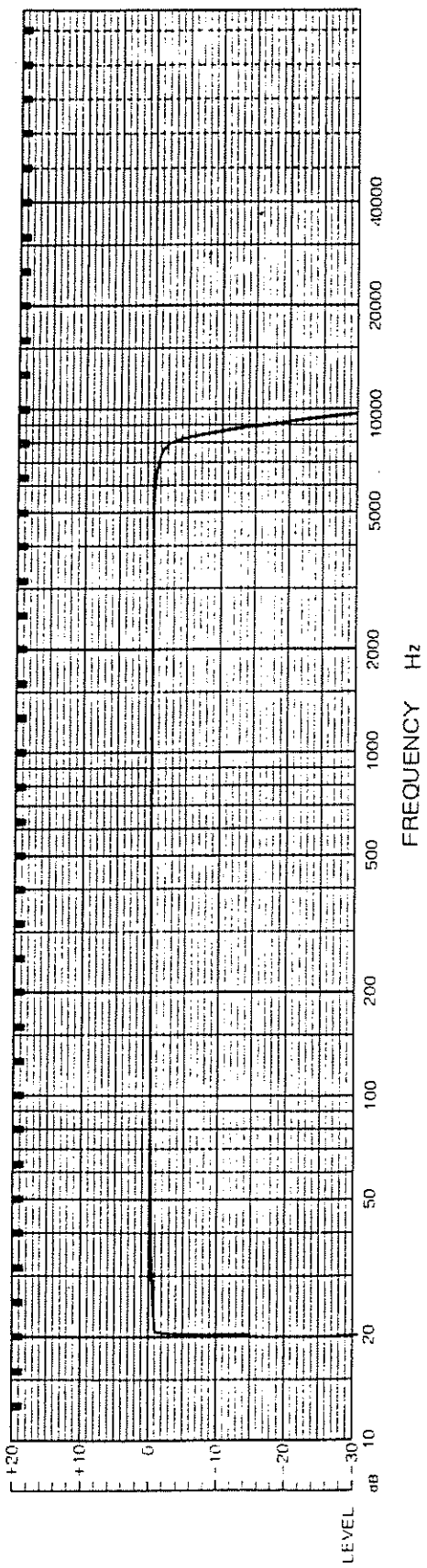

Specifications

Digital Delay • SDE-1000

(Input)

- Input Level -20dBm
 -35dBm
- Input Impedance 560k Ω (-20dBm)
 560k Ω (-35dBm)

(Output)

- Output Level -20dBm (-3dBm max.)
 -35dBm (-18dBm max.)
- Output Impedance 570 Ω (-20dBm Mixed)
 1.8k Ω (-20dBm Delay)
 100 Ω (-35dBm Mixed)
 330 Ω (-35dBm Delay)

(General Performance)

- Delay Time Range
 0 to 375/0 to 750ms (x 1.5VR min.)
 0 to 562/0 to 1125ms (x 1.5VR max.)
 0 to 10ms (0.1ms step) 10 to 1125ms (1ms step)
- Frequency Characteristic
 10Hz to 100kHz +0, -1dB (Direct)
 10Hz to 17kHz +0.5, -3dB (Delay 0 to 375ms)
 10Hz to 8kHz +0.5, -3dB (Delay 0 to 1125ms)
- S/N (IHF A)
 90dB (Direct) at rated input/output,
 Dynamic Range 112dB (typ)
 80dB (Delay) at rated input/output,
 Dynamic Range 90dB (typ)
- Total Harmonic Distortion
 0.05% max. (Direct) at rated input/output
 0.08% typ. 0.2% max. (Delay) 1kHz at rated input
- Delay Accuracy $\pm 0.4\%$

(Controls)

INPUT Attenuator
MODULATION RATE Knob
MODULATION DEPTH Knob
FEEDBACK Level Knob
DELAY Output Level Knob
Delay Time Expanding Knob
DELAY TIME Button (Up, Down)
MODULATION FOOT CONTROL

(Switches)

Memory Channel Selector Switches (1, 2, 3, 4)
FEEDBACK Switch
Delay Range Switch
Delay Phase Switch
Modulation Switch
POWER Switch
Input/Output Level Selector Switch

(Display Windows/Indicators)

DELAY TIME Display
Input Level Indicators
DELAY ON/OFF Indicator
Modulation RATE Indicator
Modulation Indicator
Memory Channel Indicators
FEEDBACK Indicator
Delay Range Indicator
Delay PHASE Indicator

(Jacks)

INPUT Jack
DELAY OUTPUT Jack
MIXED OUTPUT Jack
DELAY Jack
HOLD Jack
PRESET Shift Jack
PLAYMATE Jack

(Consumption) 17W

(Dimensions)

482(W) x 46(H) x 310(D) mm
19(W) x 1-13/16(H) x 12-3/16(D) in.
19" Rack mount (EIA-1U)

(Weight)

5kg/11lb.

(Accessories)

Connection Cable x 2

* Specifications are subject to change without notice.

Options



Foot Switch FS-1

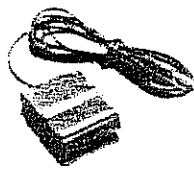

Pedal Switch DP-2

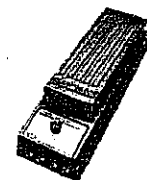

Foot Volume FV-200

 Roland®

10241

UPC 10241



10991

 Roland