

2. GENERAL BLOCK DIAGRAM

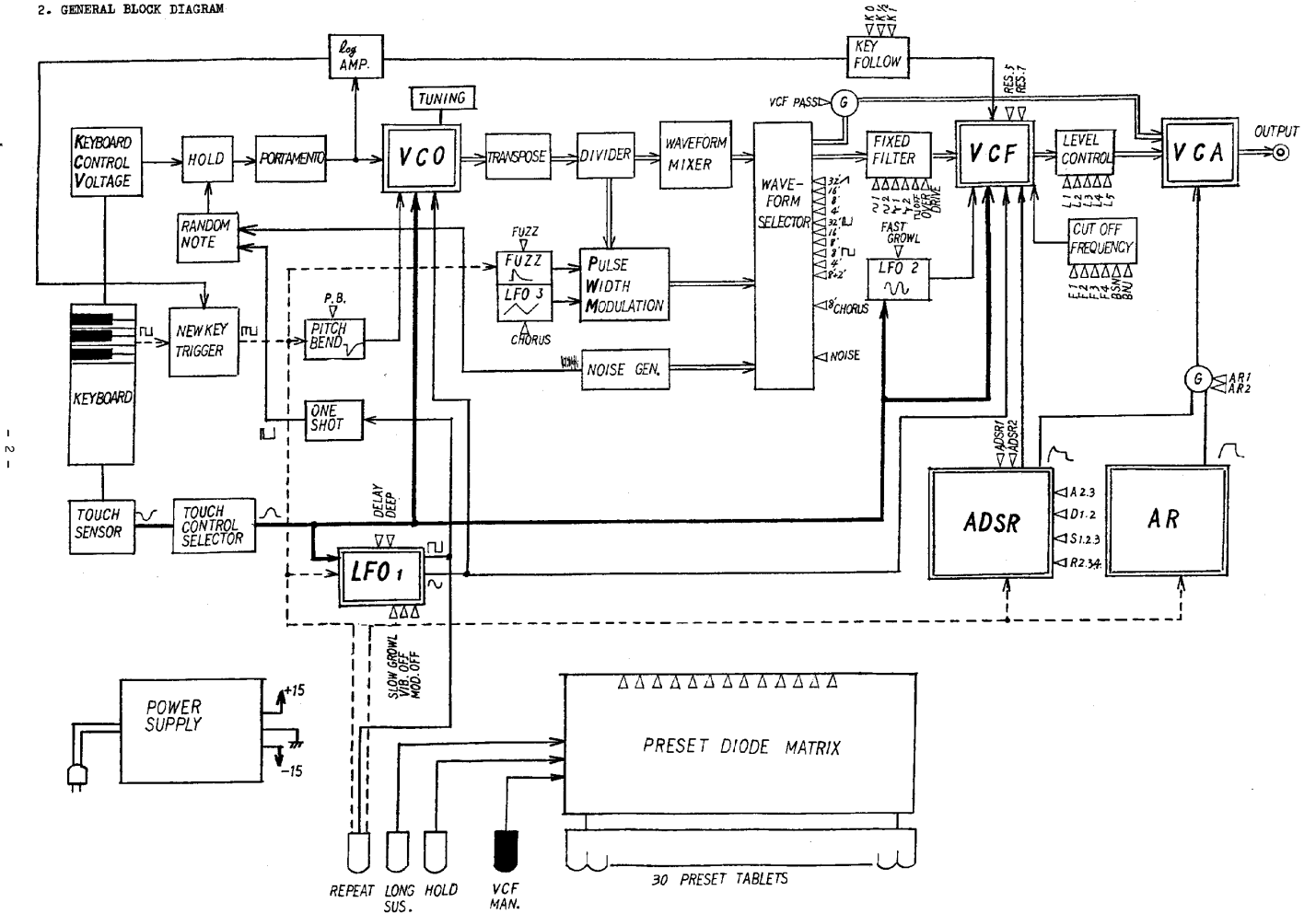

3. WIRING DIAGRAM

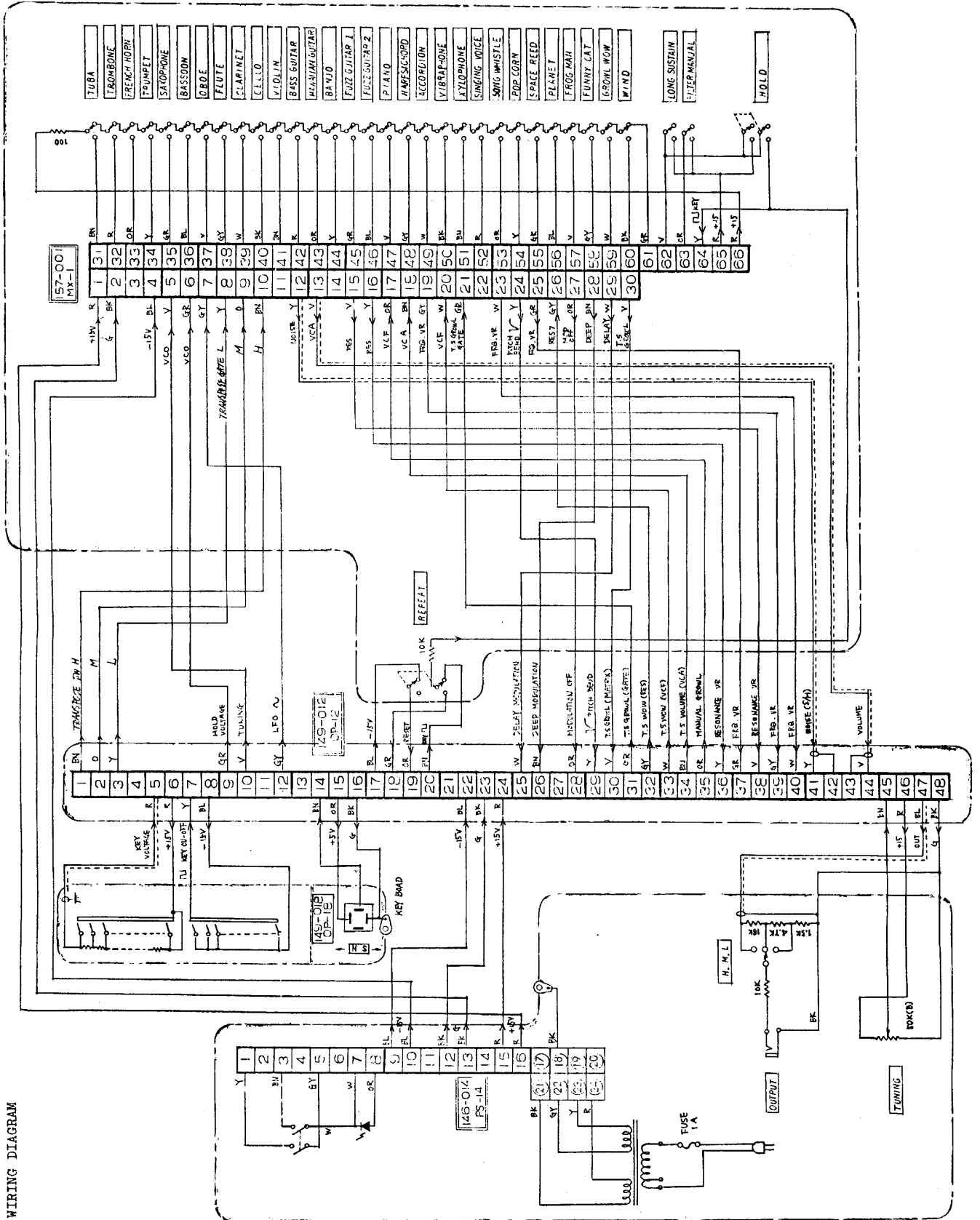

4. VCO CIRCUIT  
4-1. VCO-2 Circuit Diagram

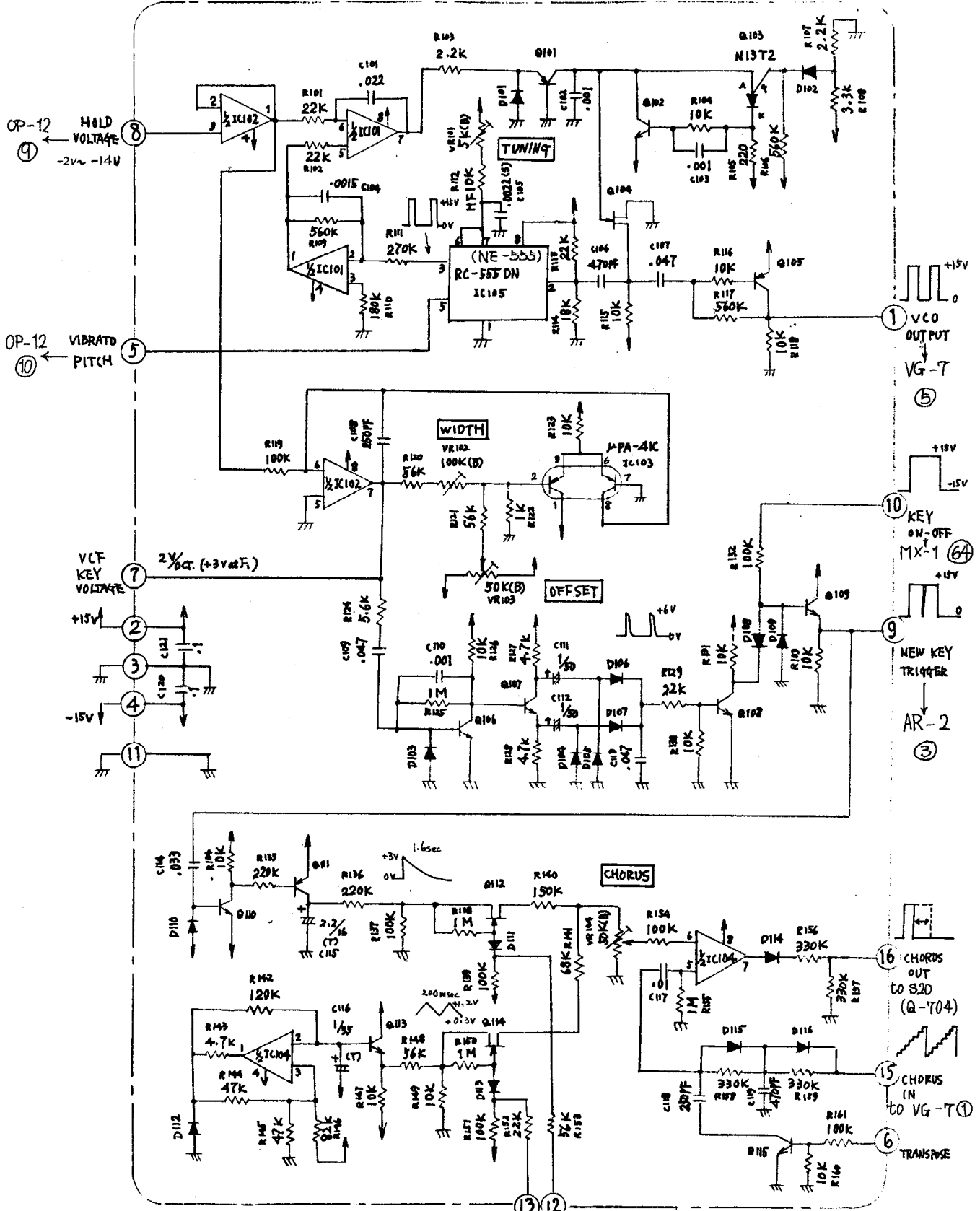

NOTES: ALL NPN TRANSISTORS ARE 25C828(R)  
 ALL PNP TRANSISTORS ARE 25A733(Q)  
 ALL FET ARE 25K44D  
 ALL DIODES ARE 1S953  
 IC 101, 102, 104 : RC4558DN OR MC-1458G

(T): Tantalum Capacitor  
 MF: Metallic Oxide Film Resistor

4-2. VC0-2 Board Assembly Parts Layout

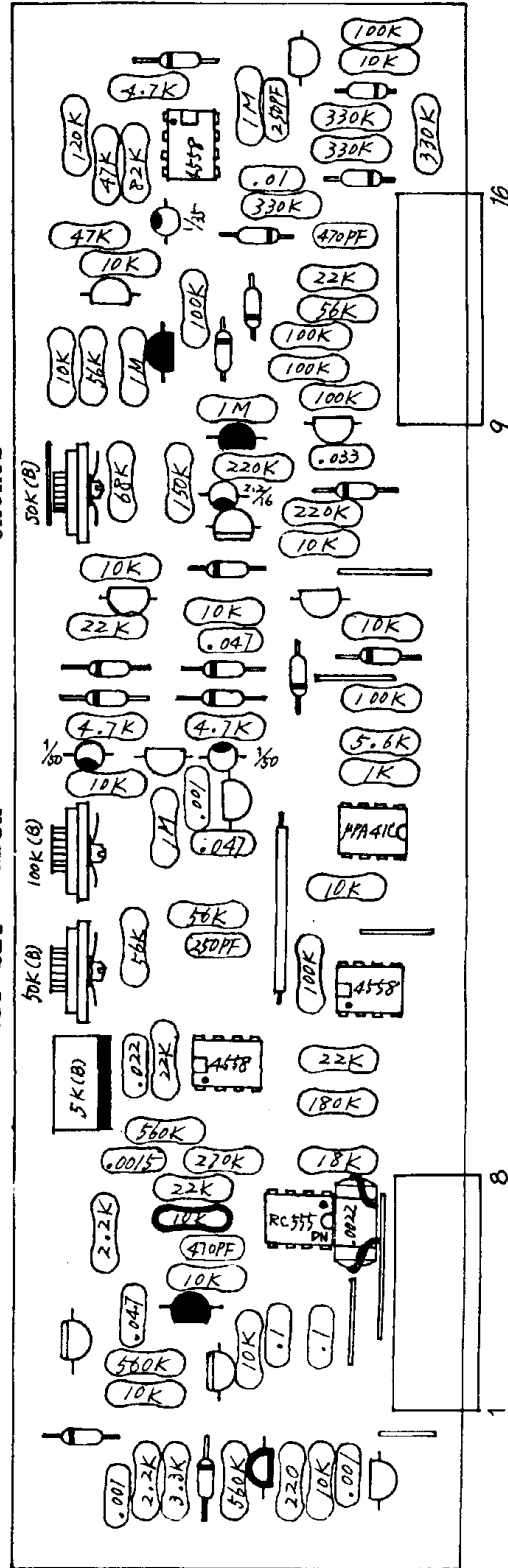
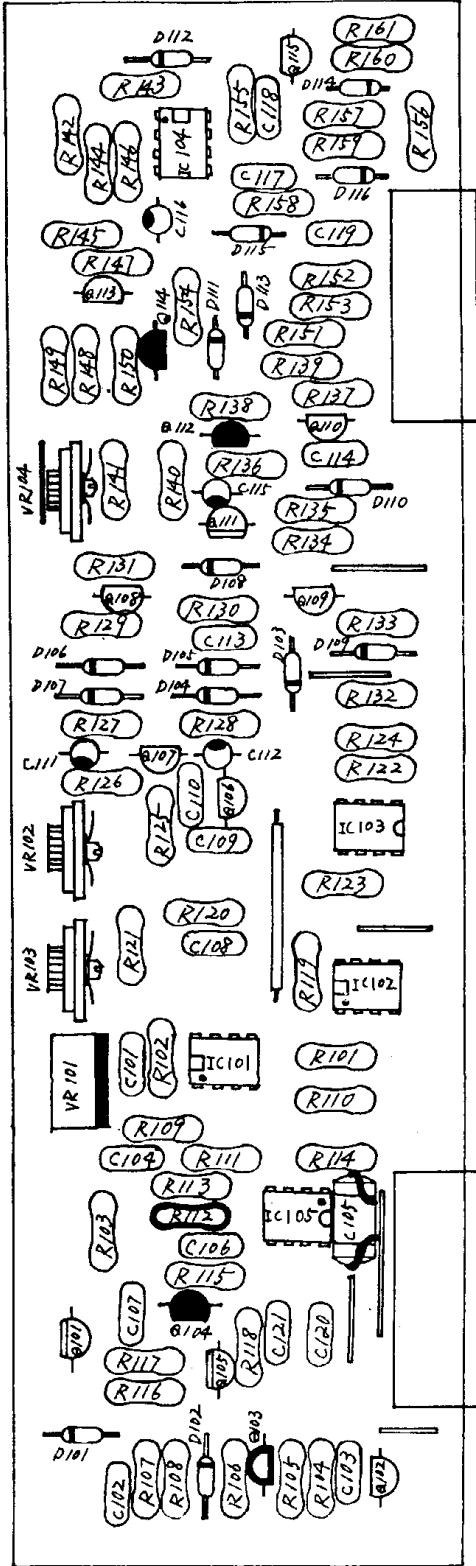

- 2SC828(R)
- 2SA733(Q)
- 2SK44D  
(or 2SK30Y)

- 1S953  
(or 7S2473)
- Metallic Oxide  
Film Resistor

5. VG-7 CIRCUIT

5-1. VG-7 Board Assembly Parts Layout

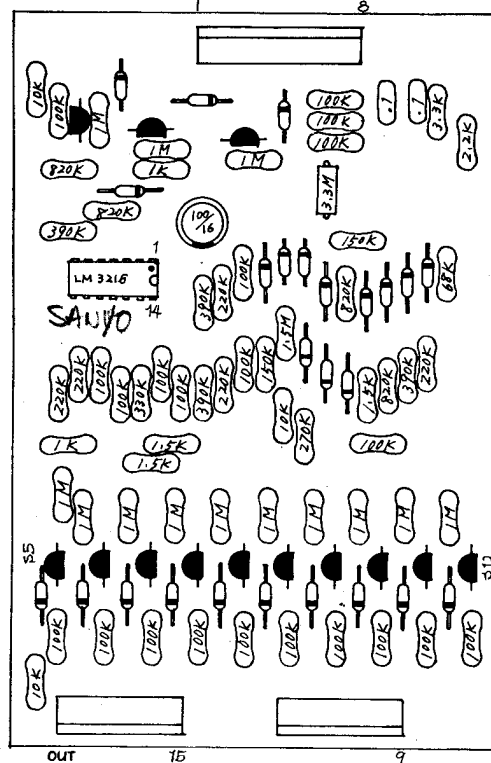
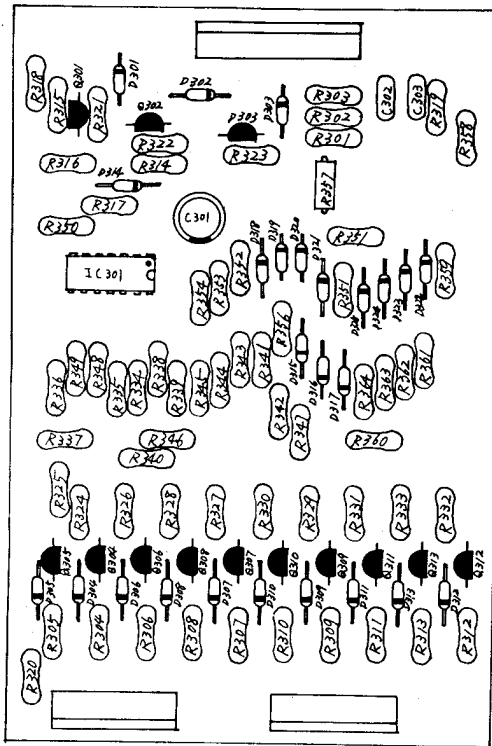

● 2SK44D (or 2SK30Y)  
 ⚡ 1S953 (or 1S2473)

5-2. VG-7 Circuit Diagram

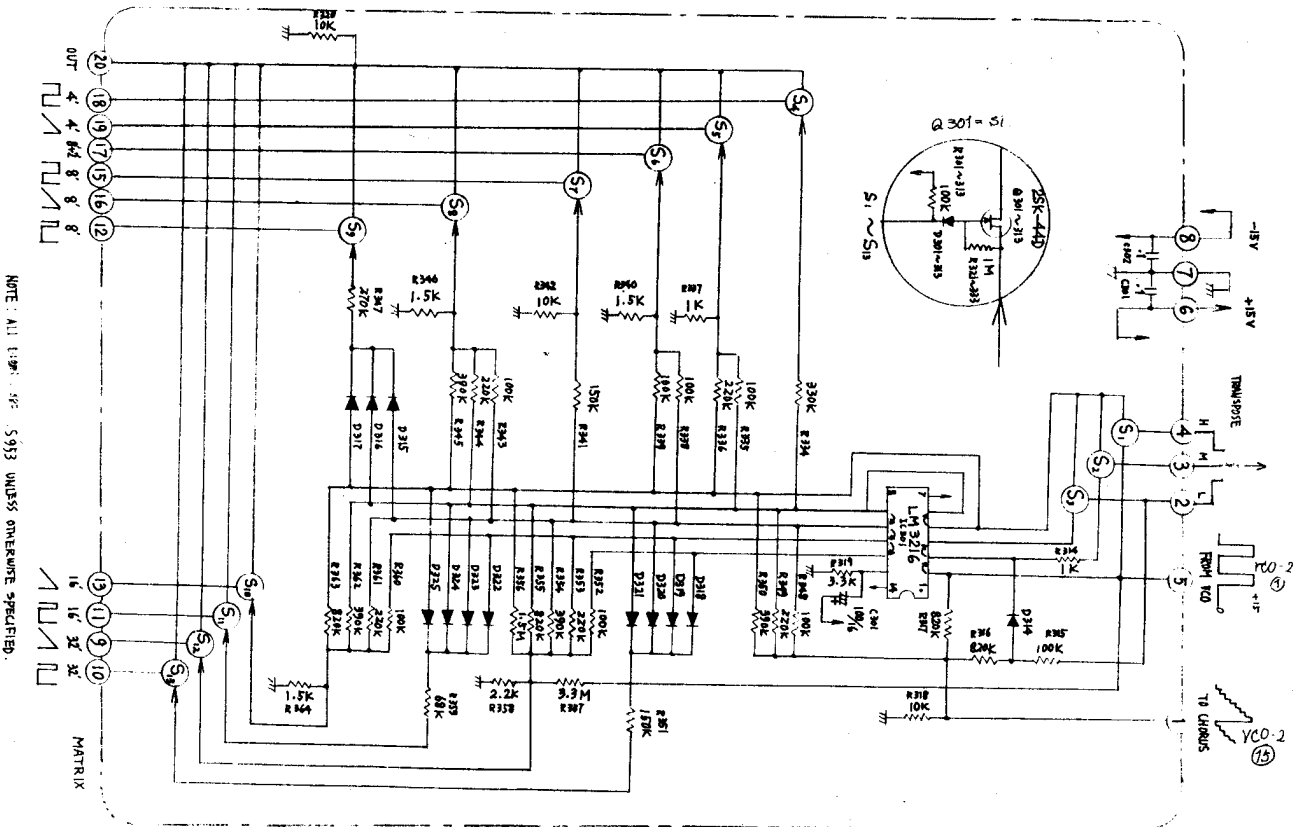

9. MX-1 CIRCUIT

9-1. MX-1 Circuit Diagram

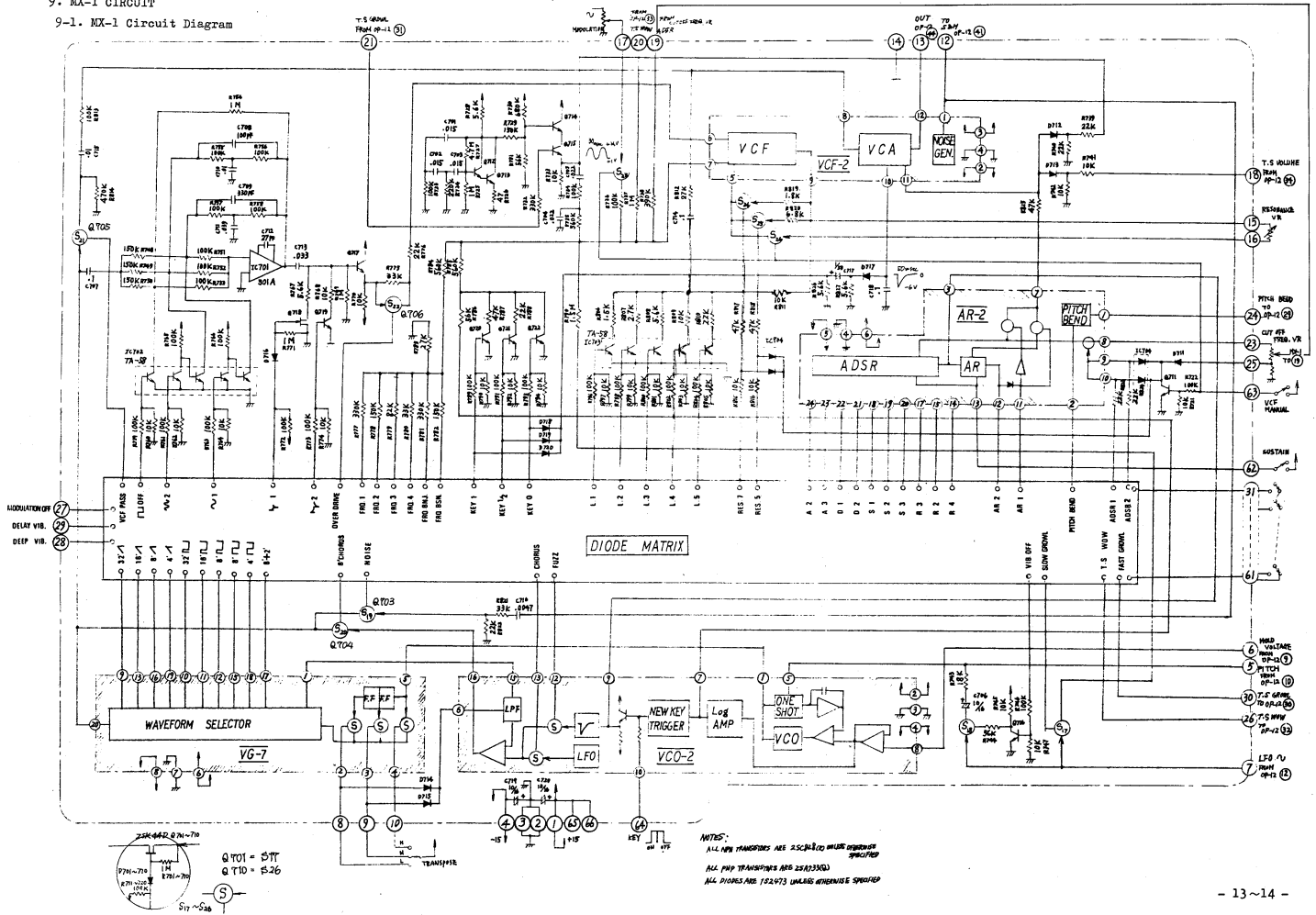

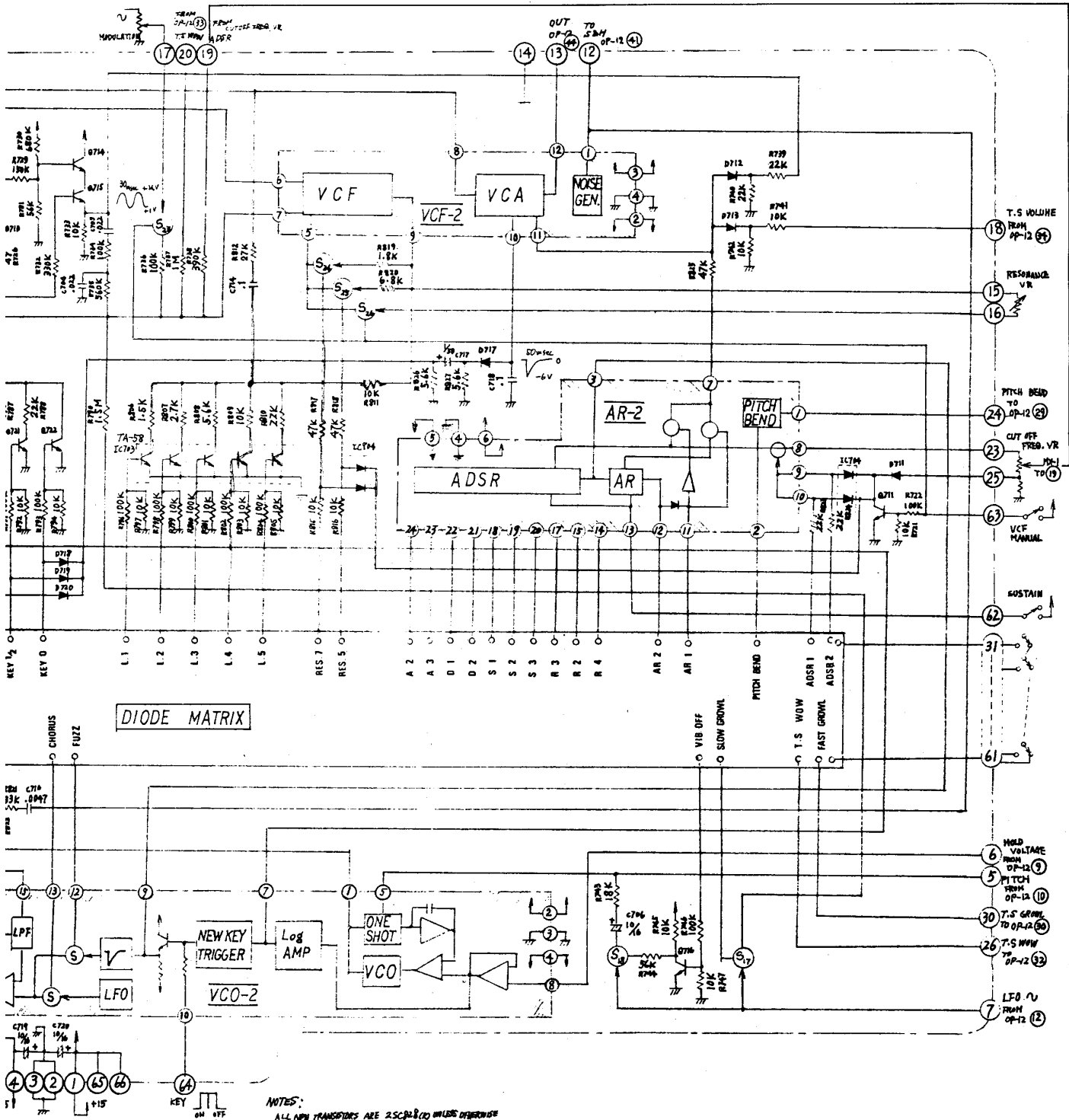

NOTES:  
 ALL NPN TRANSISTORS ARE 2SC2907 UNLESS OTHERWISE SPECIFIED  
 ALL PNP TRANSISTORS ARE 2SA1330  
 ALL DIODES ARE 1S2473 UNLESS OTHERWISE SPECIFIED

6. VCF-2 CIRCUIT  
6-1. VCF-2 Board Assembly Parts Layout

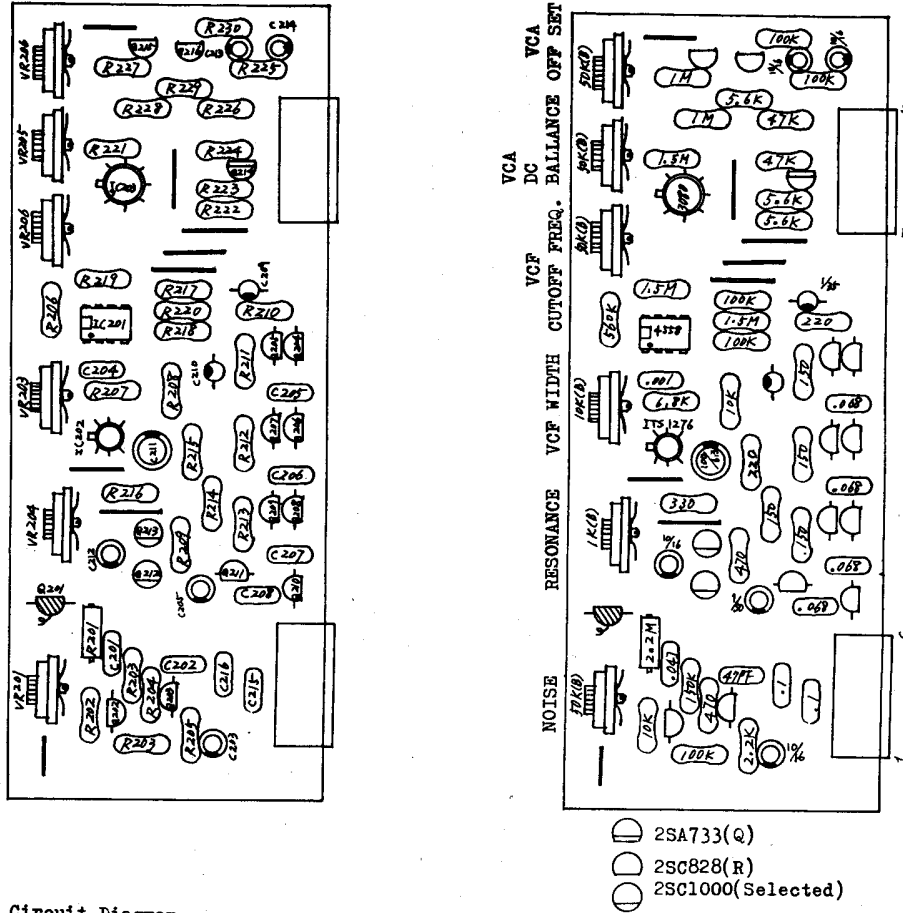

6-2. VCF-2 Circuit Diagram

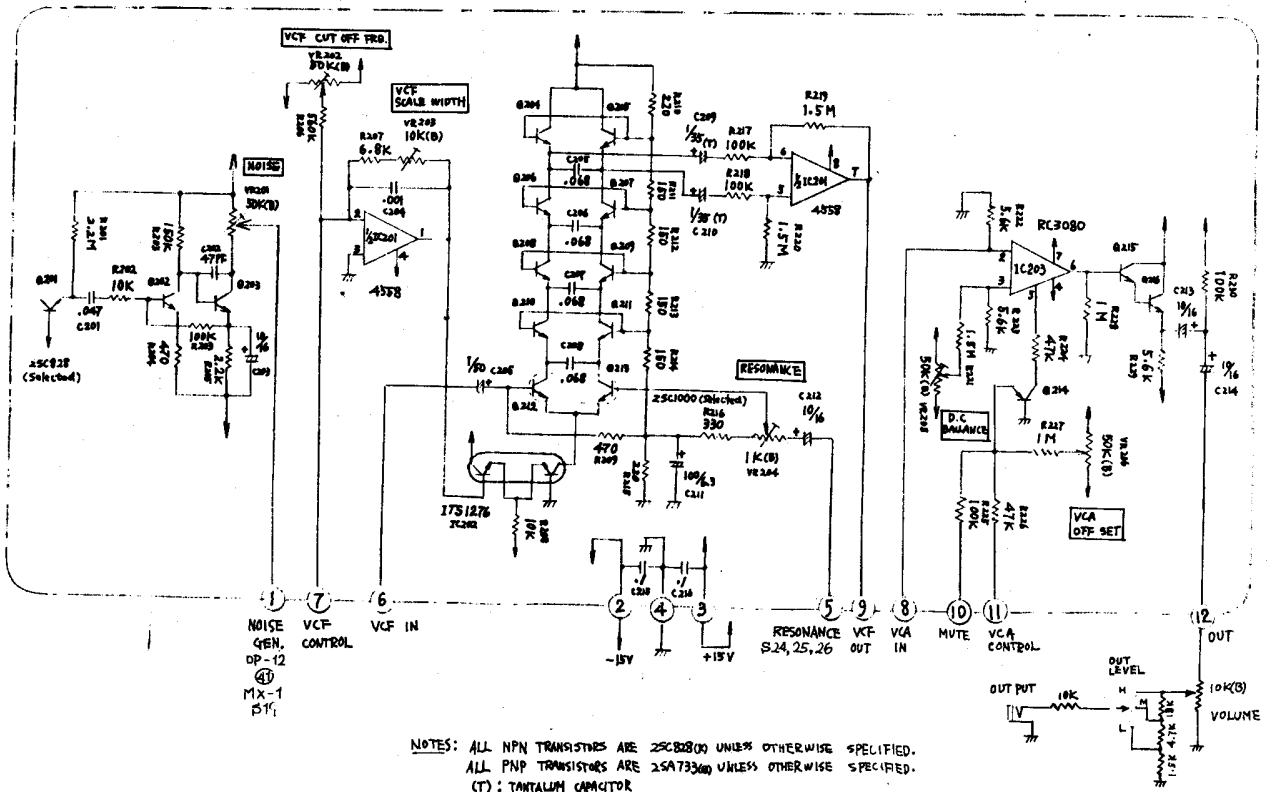



7. AR-2 CIRCUIT  
7-1. AR-2 Board Assembly Parts Layout

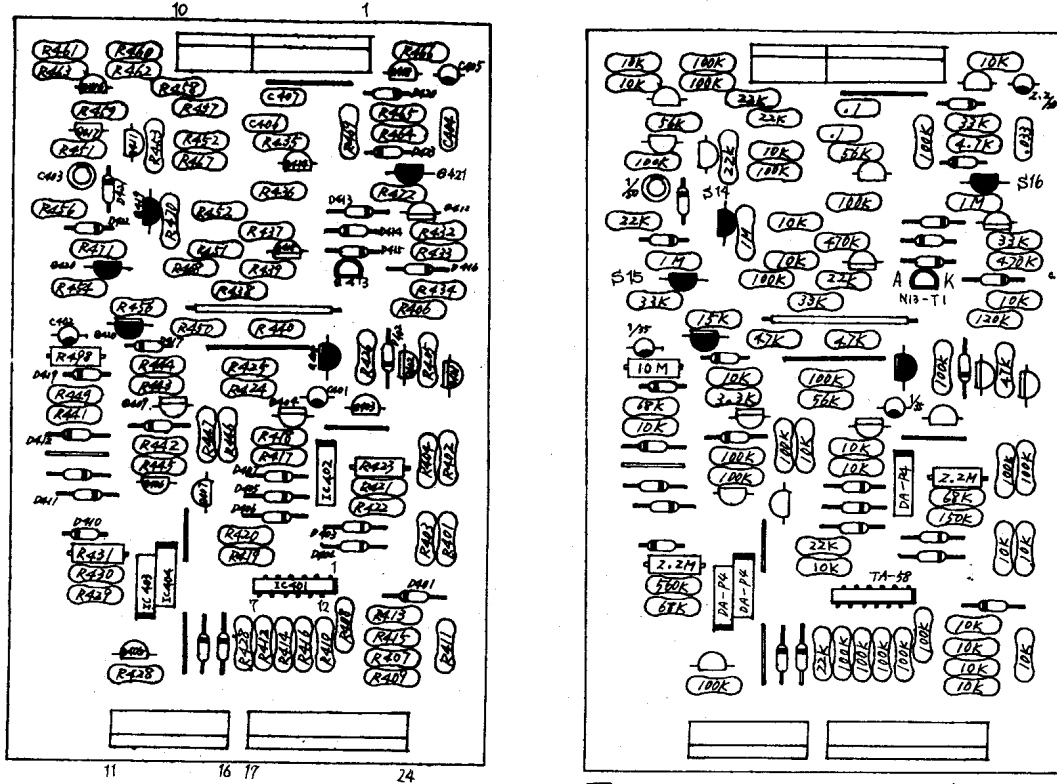

7-2. AR-2 Circuit Diagram

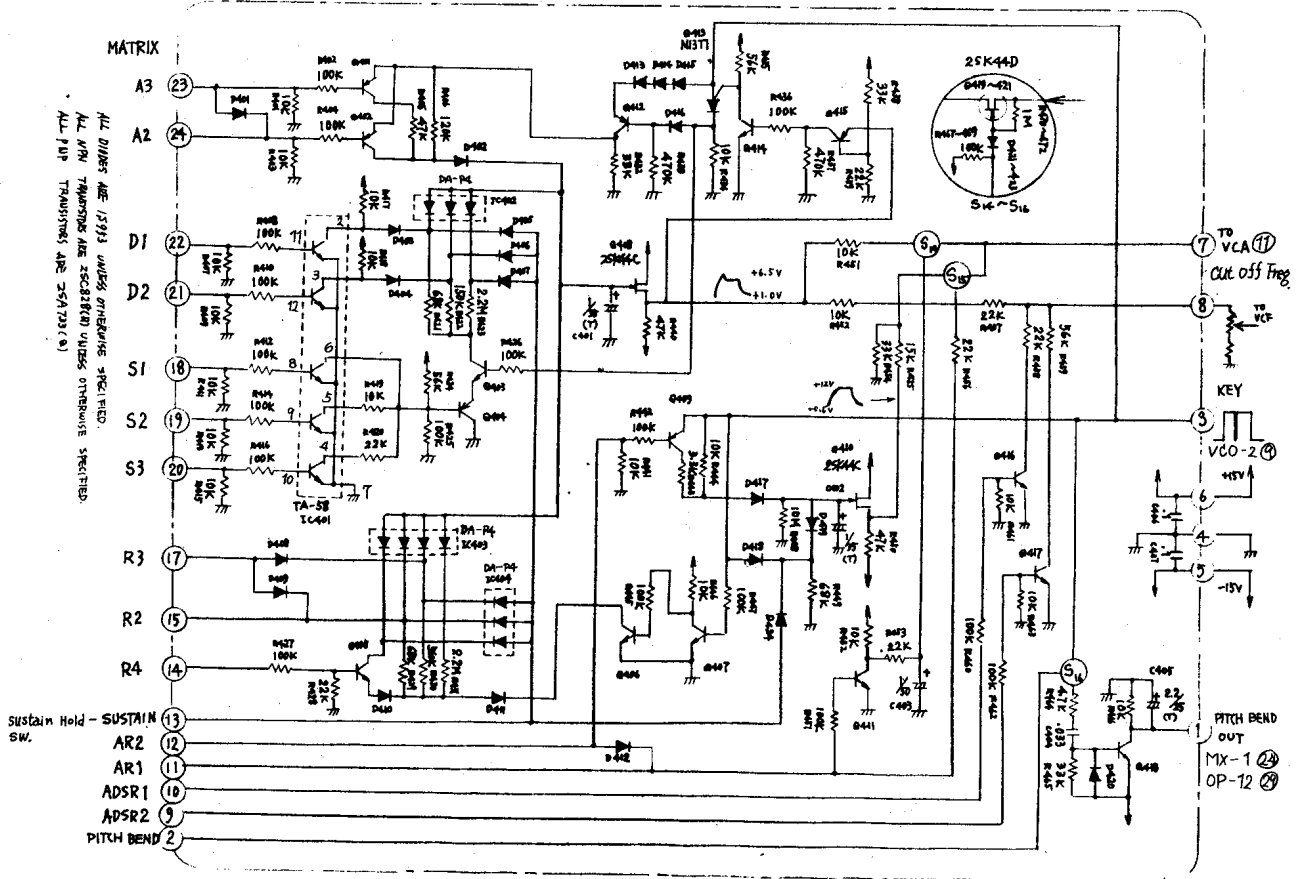



8-2. OP-12 Board Assembly Parts Layout

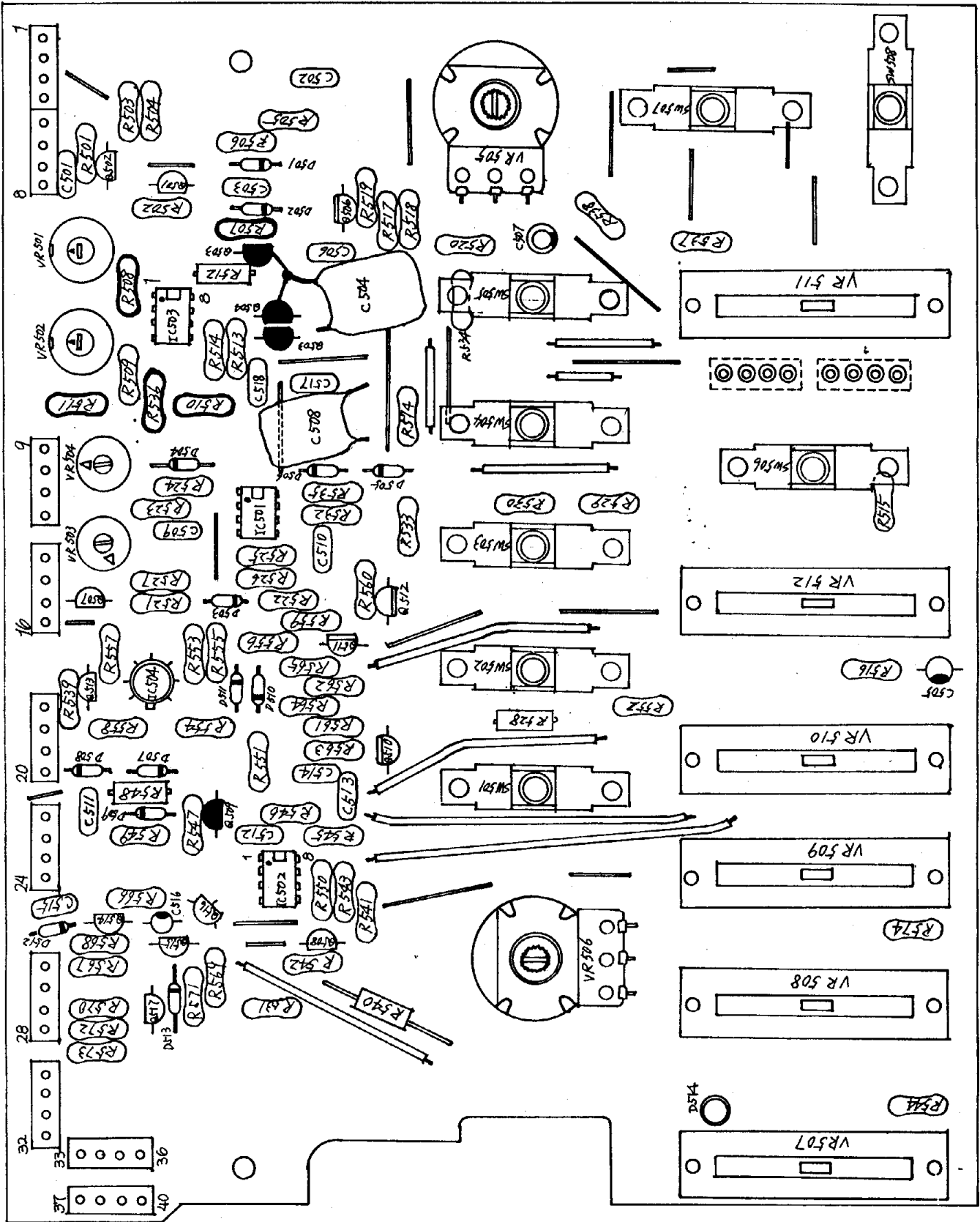



8-3. Rear Side of OP-12 Board

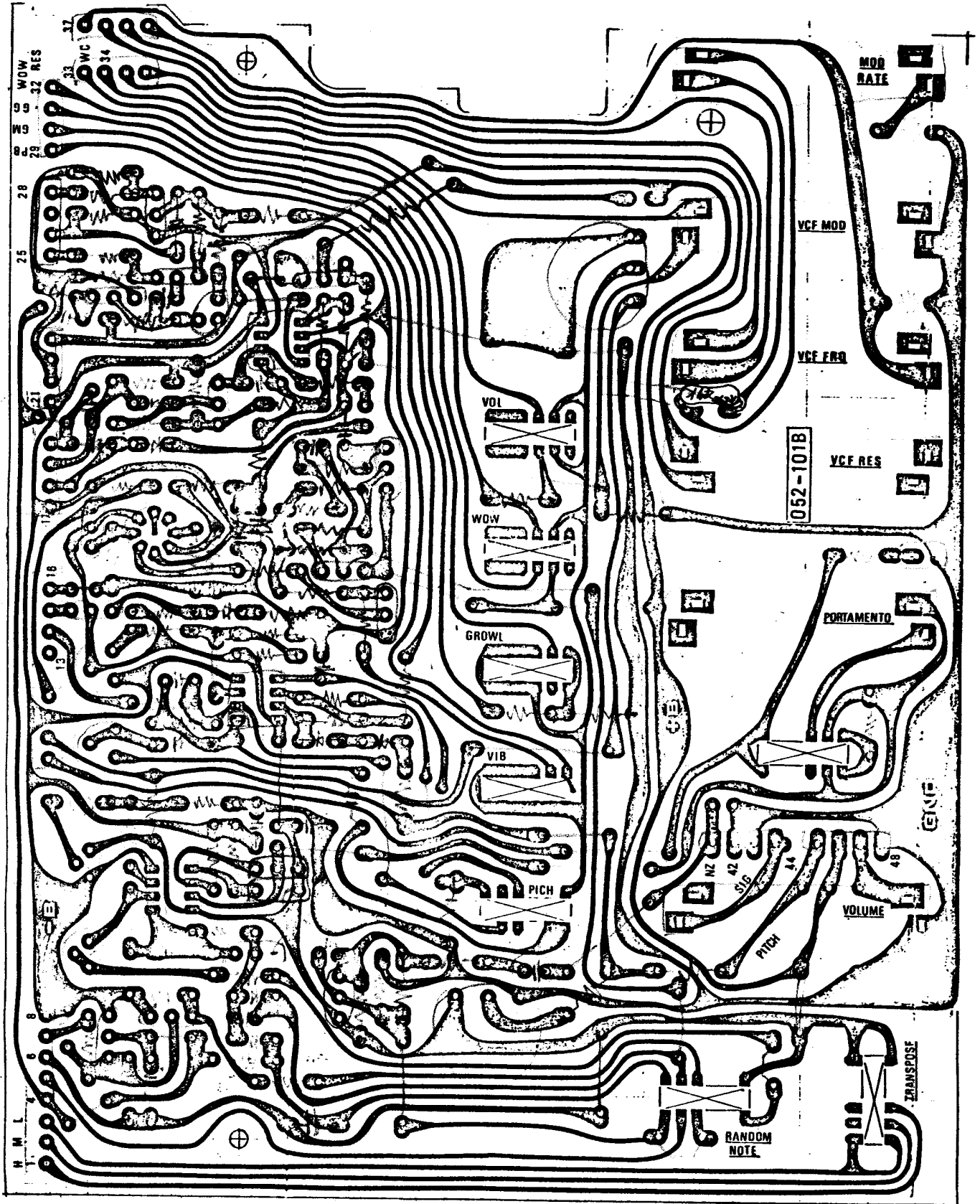

9-2. Diode Matrix MX-1 Circuit Diagram

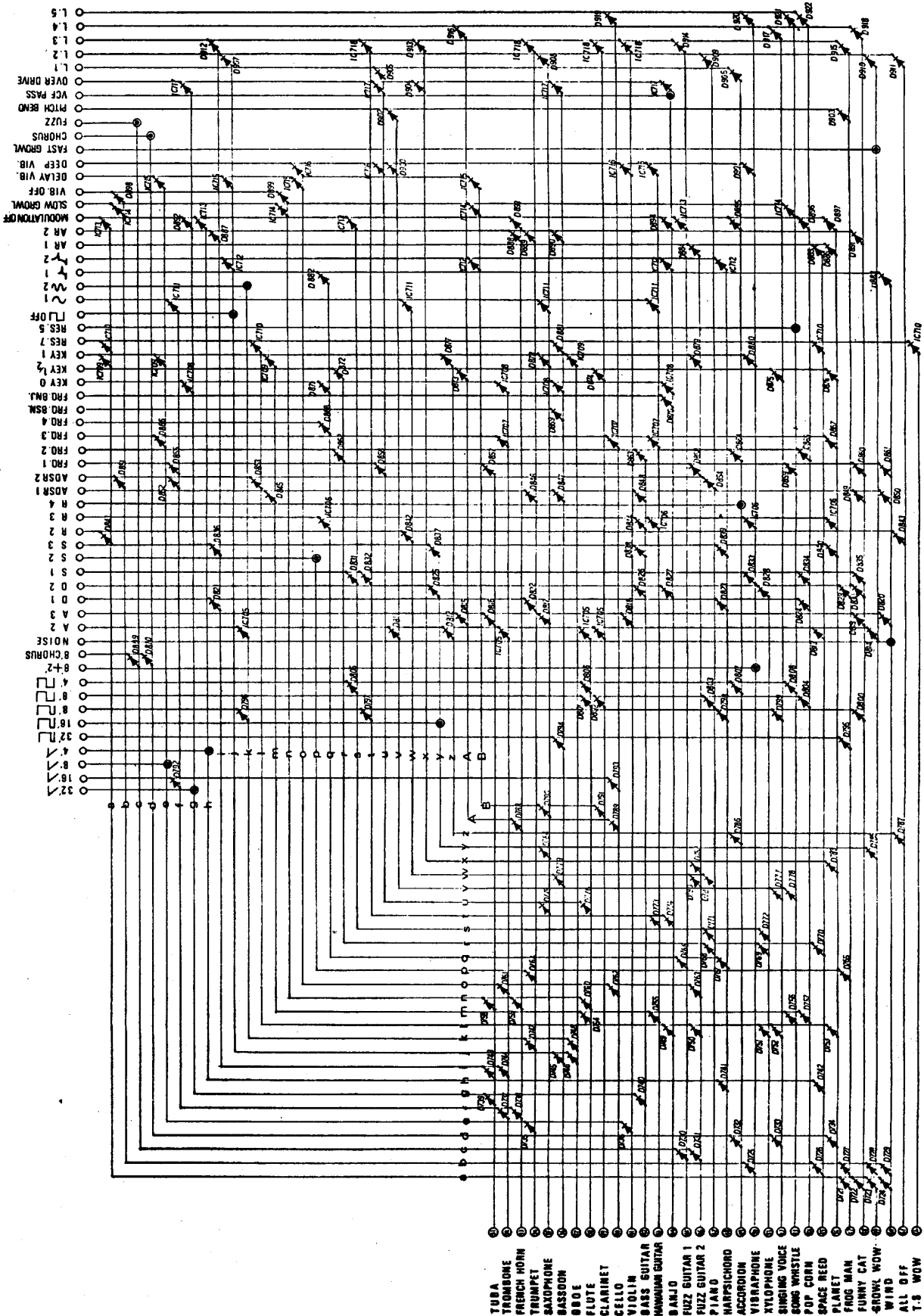

9-3. MX-1 Board Assembly Parts Layout

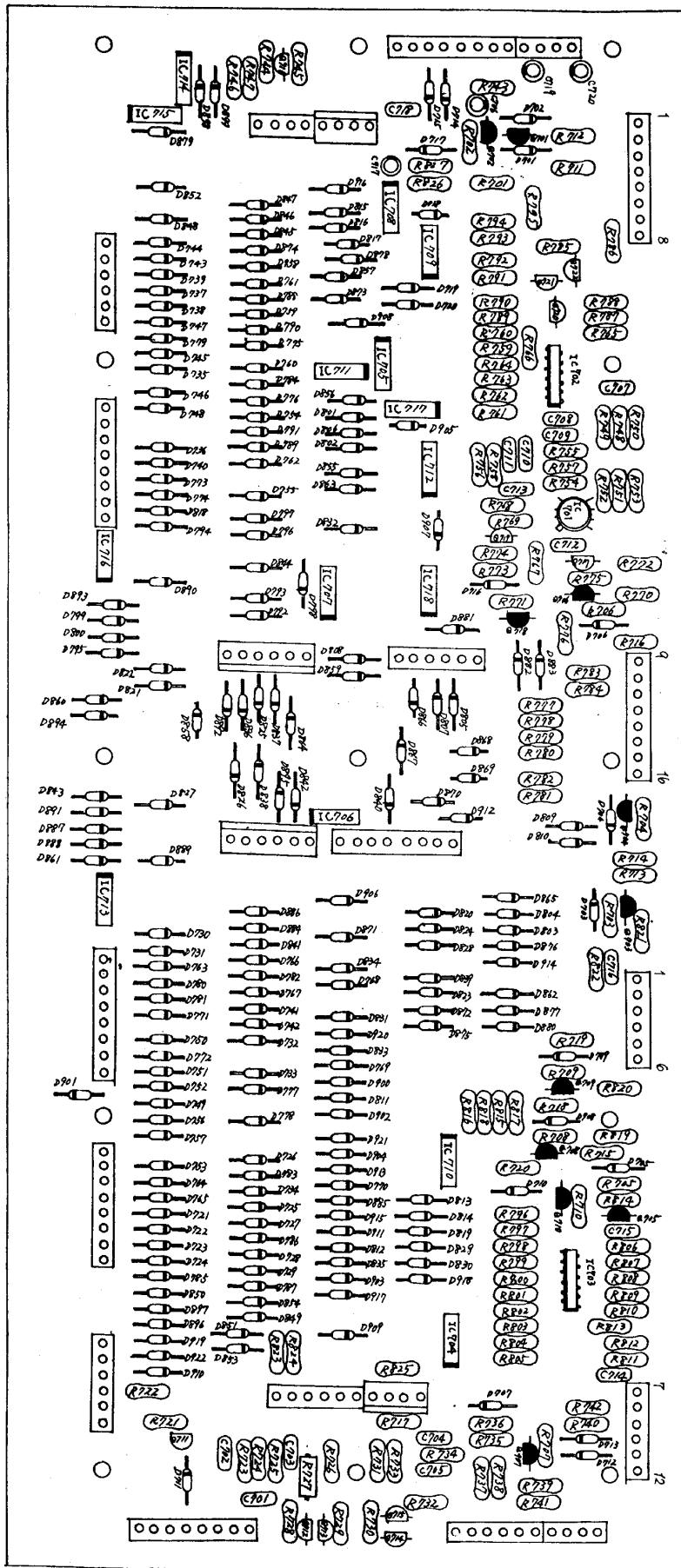





9-4. Rear Side of MX-1 Board

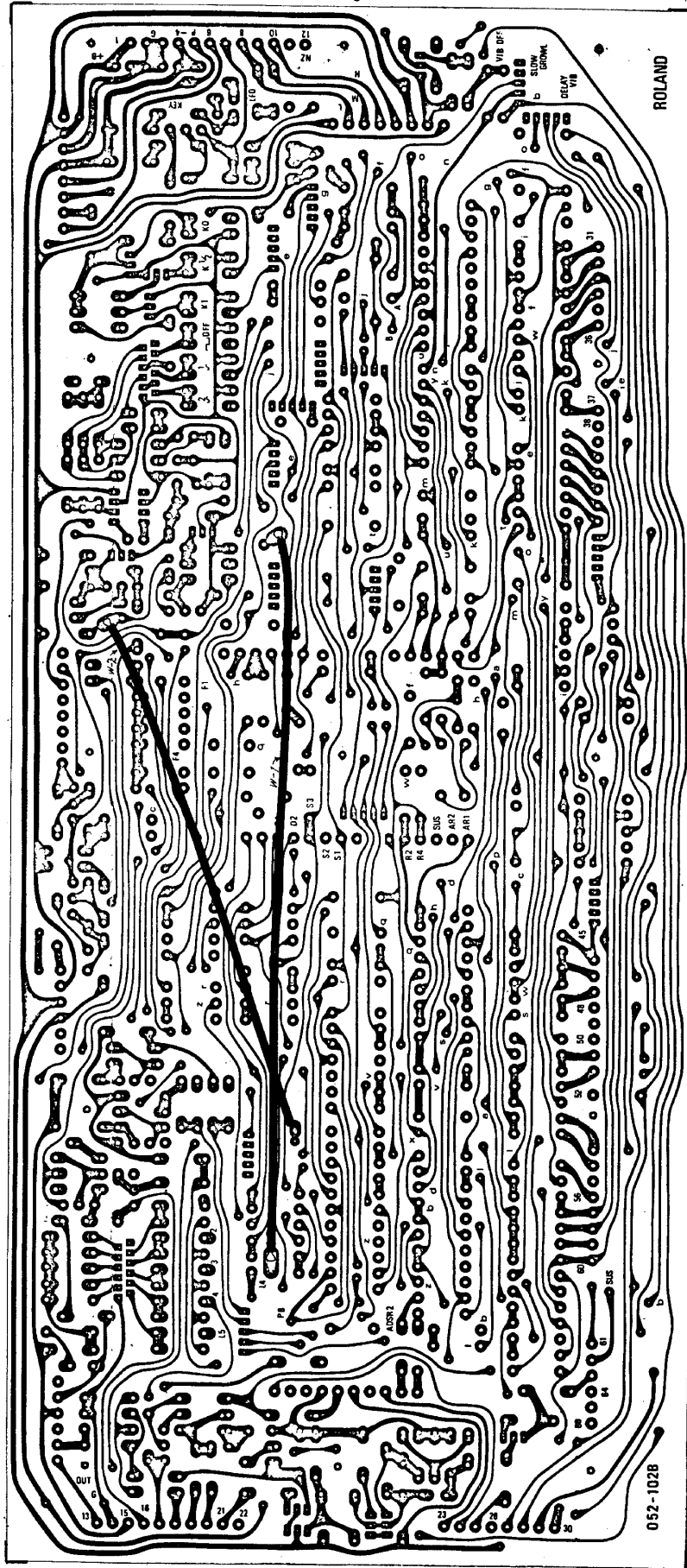

9-5. Both Side Circuit Patterns of MX-1 Board

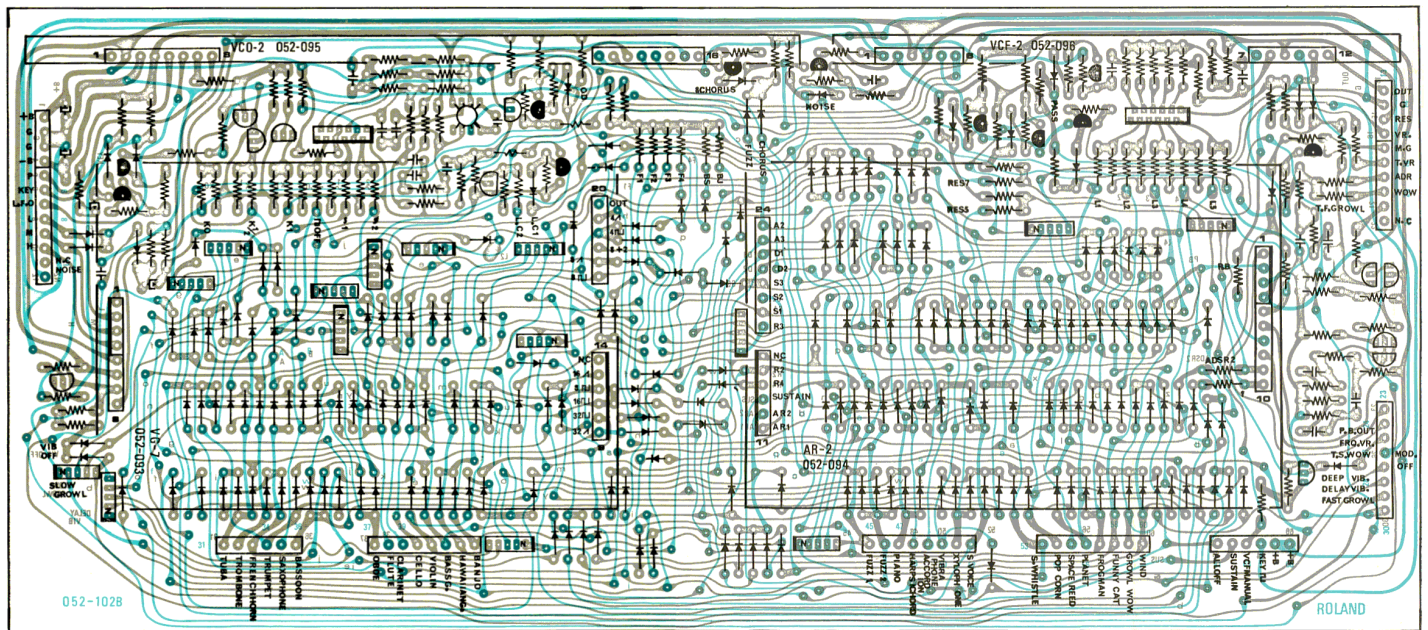

9-5. Matrix Composition Chart

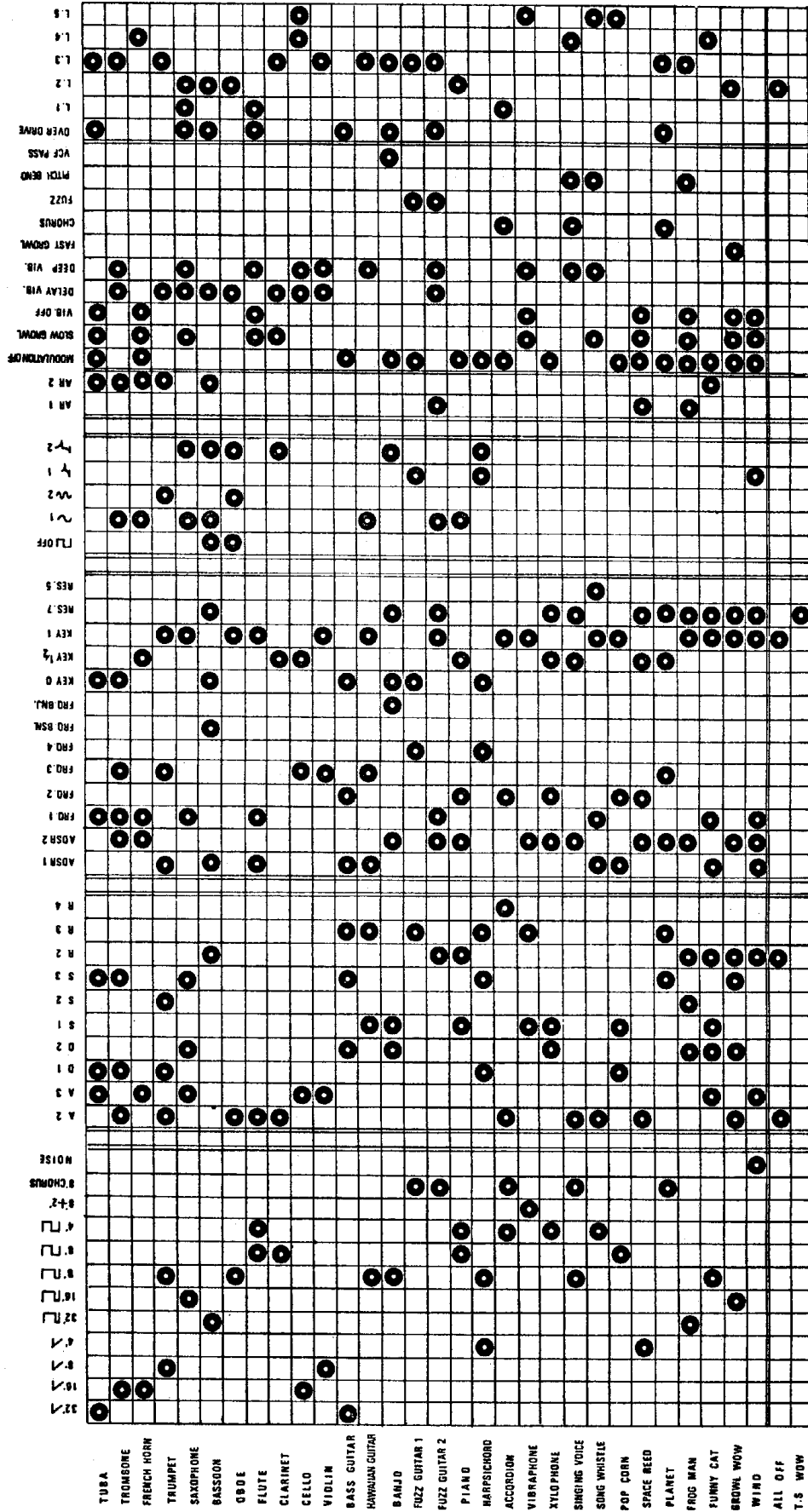

10. PC-3 CIRCUIT  
 10-1. PS-14 Board Assembly Parts Layout

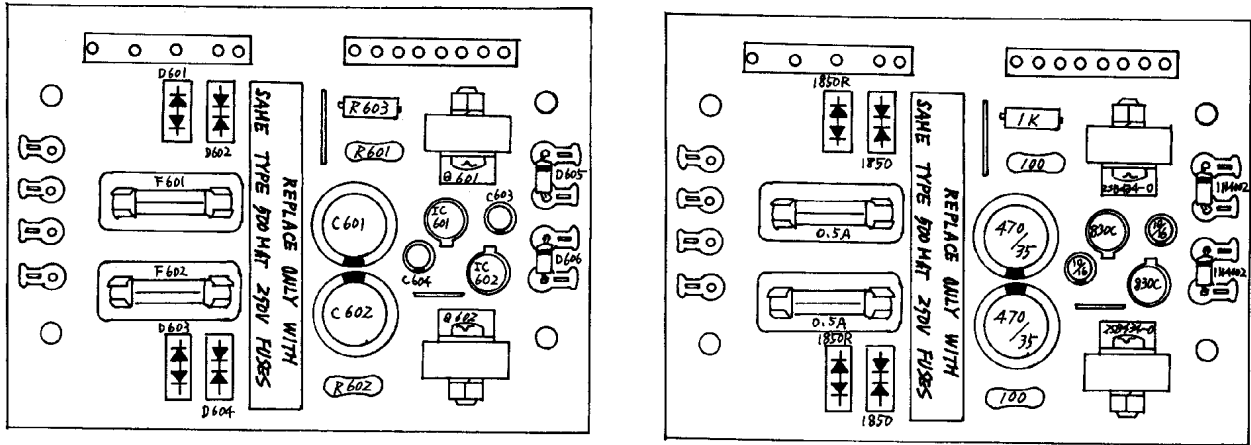

10-2. PC-3 Circuit Diagram

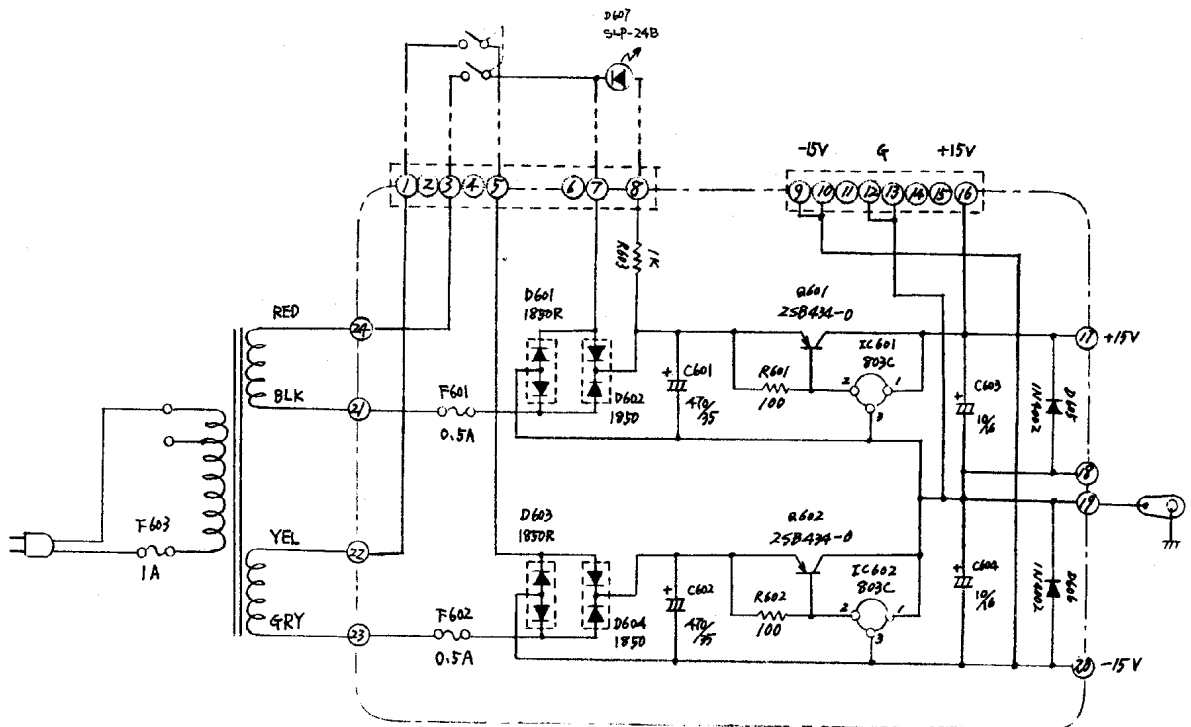

## 11. ADJUSTMENT

1. Plug the line cord plug into a standard AC outlet.
2. Connect the output jack on rear panel to an amplifier or the external input jack of an organ.
3. Connect the oscilloscope ground lead to the chassis and the scope vertical input lead to the No.44 terminal of OP-12.
4. Turn on the AC Power Switch.
5. Before adjusting, allow at least 3 minutes as a warmup time.

### 11-1. Tuning Procedure

- 1) Turn the Pitch control to the center of its rotation.
  - 2) Turn the Tuning control (rear panel) to the center of its rotation.
  - 3) Set the Transpose switch to the M position.
  - 4) Set the Volume Control to the suitable position for adjustment.
  - 5) Set the Filter control to the center position.
  - 6) Turn off all the tab switches except Popcorn and Hold.
  - 7) Turn off all the lever switches and set the controls to the minimum position except abovementioned.
  - 8) There are two methods for tuning.
    - (1) Feed a signal from an audio generator to the horizontal input of the scope, and adjust the VCO controls to display stationary wave on the screen.
    - (2) Use the "beat note" sound heard when the loudspeaker reproduces two note of almost the same frequency. The beat note sound can best be described as a "throbbing" or "pulsating" sound.

As the VCO is adjusted closer to standard signal, the beat rate will slow down and the beat will finally disappear at "zero beat."  
And the VCO may be on correct frequency.
- \*1. Set the two trim pot.(L-Tune and H-Tune) on OP-12 to the center position.
  - \*2. Depress the F2 key, set the frequency to 349Hz by turning the "TUNING" trim pot. on the VCO-2.
  - \*3. Depress the F1 key, set the frequency to 349/2 Hz by turning the "L-TUNE" trim pot. on the OP-12.
  - \*4. Repeat steps 2 and 3.
  - \*5. Depress the F4 key, set the frequency to 1397Hz by turning the "H-TUNE" on the OP-12.
  - \*6. Finally set the F2 frequency to 349Hz by "TUNING"(VCO-2).

Confirm each frequency F1, F3 and F4.

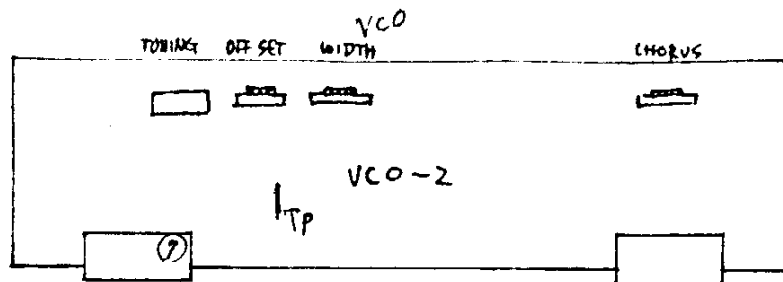
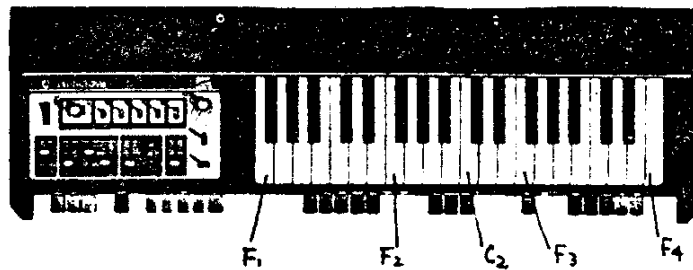
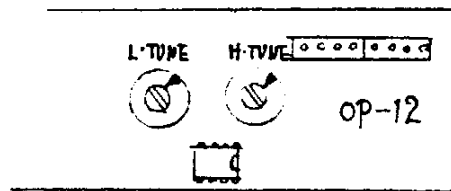

11-2. VCF control voltage adjustment

- 1) Connect a VOM or VTVM across terminal No.7 of VCO-2 or test point and a grounded point of chassis.
- 2) Press F1 key, continue turning the " OFF SET " trim pot. on VCO-2 until +3volts appears at the No.7 terminal.
- 3) Press F4 key, continue turning the " WIDTH " trim pot. on VCO-2 until +9volts appears.

NOTE

Voltage difference for one octave should be two volts.

F1 +3V, F2 +5V, F3 +7V, F4 +9V (step up by 2 Volts.)

11-3. VCF RESONANCE adjustment

- 1) Turn off all the tab switches except " MANUAL FILTER ", " MODULATION " knob should be set to zero position.

Turn up the RESONANCE knob on the panel to the 9 position.

Adjust the " RESONANCE " trim pot. until the VCF oscillates, and then back off until the oscillation just goes off.

Turn off the " MANUAL FILTER " tab switch.

Depress the " PLANET " tab switch.

Being sure that a waveform similar to the figure should be seen on the scope.

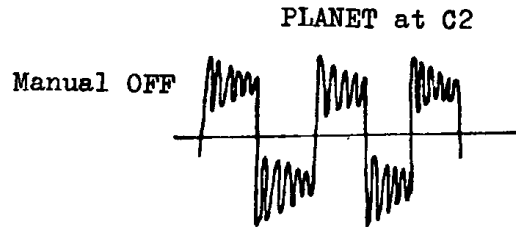
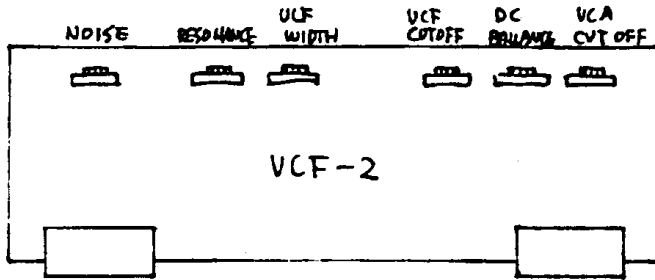

- 2) Turn off the " PLANET " tab switch.  
 Depress the " FILTER MANUAL " tab.  
 Set the CUTOFF FREQUENCY knob to proper position.  
 Set RESONANCE knob to max. position.  
 While depressing the keys of C1 and C2 alternately, adjust the " WIDTH " trim pot on the VCF-2 to get one octave musical interval.
- 3) Turn on " SINGING VOICE " tab, all other tab switches should be off.  
 Set the " CUTOFF FREQ " knob to 5 position.  
 While holding the C2 key down, adjust " VCF CUTOFF " trim pot on VCF-2 so as to get the output waveform looks like the figure shown below.

Singing Voice at C2

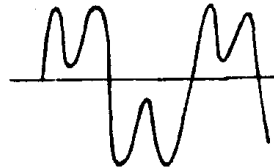

#### 11-4. CHORUS adjustment

- 1) Depress the " FUZZ 1 " tab switch , all other tab switch should be off.

Turn the TRANSPOSE switch to "H" position.

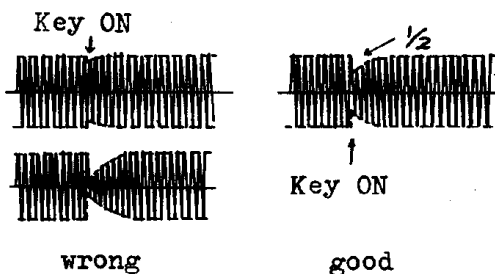

Depress the F4 key, adjust the "CHORUS" trim pot on VCO-2 so that a pulse wave does not disappear at the starting point. (See the figure shown left.)

- 2) Turn the " TRANSPOSE " switch to "L" position.

Press down the F1 key, a pulse wave seen on the scope is sailing and shuttling as shown in the figure shown below.

And then, turn the Transpose switch to "M" position.

While holding a key down, depress the " ACCORDION " tab switch, a Chorus of the note should be heard.

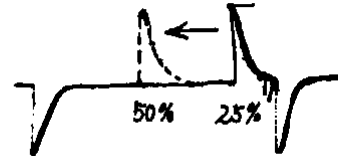

#### 11-5. VCA adjustment

- 1) Turn off all the tab switches except the " REPEAT " tab switch.

Press any key. If any pulse wave is seen on the scope, it should be reduced by the " DC BALANCE " on the VCF-2.

- 2) Depress the " POP CORN " tab switch.

The DECAY TIME of its wave should be adjusted to 100mSec. by " VCA CUTOFF " on the VCF-2.

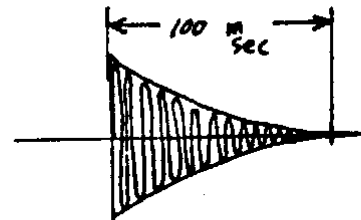

#### 11-6. TOUCH SENSITIVITY adjustment

- 1) Shift the scope vertical input lead to point A.

Adjust the " T.S OFFSET " on the OP-12 until point A's output drops to 0 volt.

- 2) Depress the " FRENCHHORN " tab switch, all other tab switch are should be off.

Turn the " PITCH BEND " to Up or Down.

Turn the " SENSITIVITY " control fully clockwise.

While holding a key down strongly (800 to 900 grams pressure), adjust the " T.S GAIN " on the OP-12 so that a note up or down by 2 degrees in Major interval.

