

# SH-2 SERVICE NOTES

## ● SPECIFICATIONS

### ● KEYBOARD

37 keys, 3 octaves

### ● VCO

AUTO BEND  
MOD (modulation depth)  
PULSE WIDTH (50% - MIN)  
PWM MODE SWITCH (ENV/MAN/LFO)  
TOTAL TUNE

### VCO-1

RANGE (32', 16', 8', 4', 2')  
WAVEFORM (∞, 1, □, ▽)  
BENDER ON/OFF SWITCH

### VCO-2

RANGE (32', 16', 8', 4', 2')  
WAVEFORM (NOISE, 1, □, ▽)  
VCO-2 TUNE  
TUNE RANGE (WIDE/NARROW)

### ● AUDIO MIXER

VCO-1 SUB  
VCO-1  
VCO-2

### ● VCF

CUTOFF FREQUENCY (10Hz - 20kHz)  
RESONANCE (0 - self oscillation)  
ENVELOPE SWITCH (ENV FOL'R, ENV  
∞, ENV √)  
ENVELOPE CONTROL  
MODULATION CONTROL  
KYBD CV CONTROL

### ● VCA

MODULATION SWITCH (HOLD, ENV ∞  
KYBD GATE □)

### ● ENVELOPE GENERATOR

ATTACK TIME (1ms - 2.5s)  
DECAY TIME (2ms - 10s)  
SUSTAIN LEVEL (0 - 100%)  
RELEASE TIME (2ms - 10s)  
GATE SELECTOR SWITCH  
(GATE-TRIG/GATE/LFO)

### ● MODULATOR (LFO)

MODE (RANDOM/□/∞)  
RATE (0.2Hz - 25Hz)  
DELAY TIME (0 - 1.5s)  
LED INDICATOR

### ● POWER SWITCH (with LED indicator)

### ● VOLUME CONTROL

### ● PORTAMENTO (0 - 5s)

### ● BENDER LEVER

### ● INPUTS/OUTPUTS

OUTPUT jack (-10dBm)  
HEADPHONE jack (stereo, 8Ω)  
CV INPUT jack (1V/oct)  
GATE INPUT JACK (+7.5V min)  
CV OUTPUT jack (1V/oct)  
GATE OUTPUT jack (OFF=0V; ON=14V)  
EXT AUDIO IN jack (0.5V p-p, max)

### ● POWER CONSUMPTION: 11W

### ● DIMENSIONS: 670(w)x305(d)x100(h)mm

### ● WEIGHT: 6.9kg

### ● ACCESSORIES: 2.5m patch cord

When ordering PCBs, suffix letter to PCB name referring to the Parts List and PCB layout.

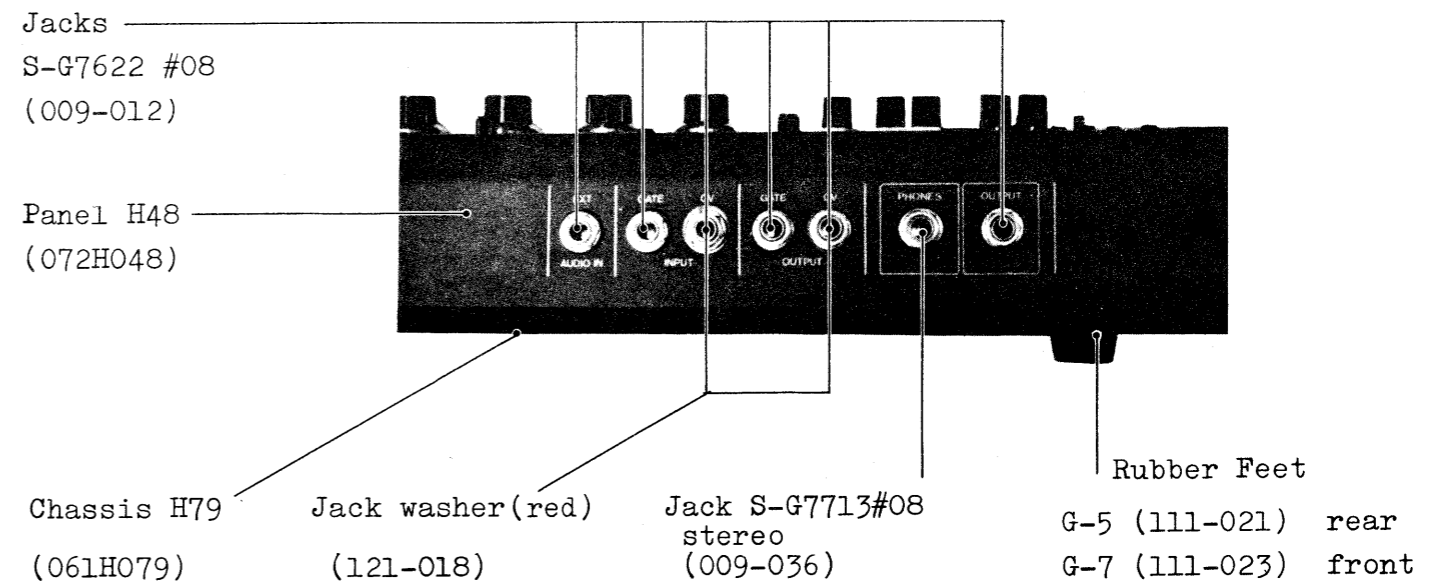
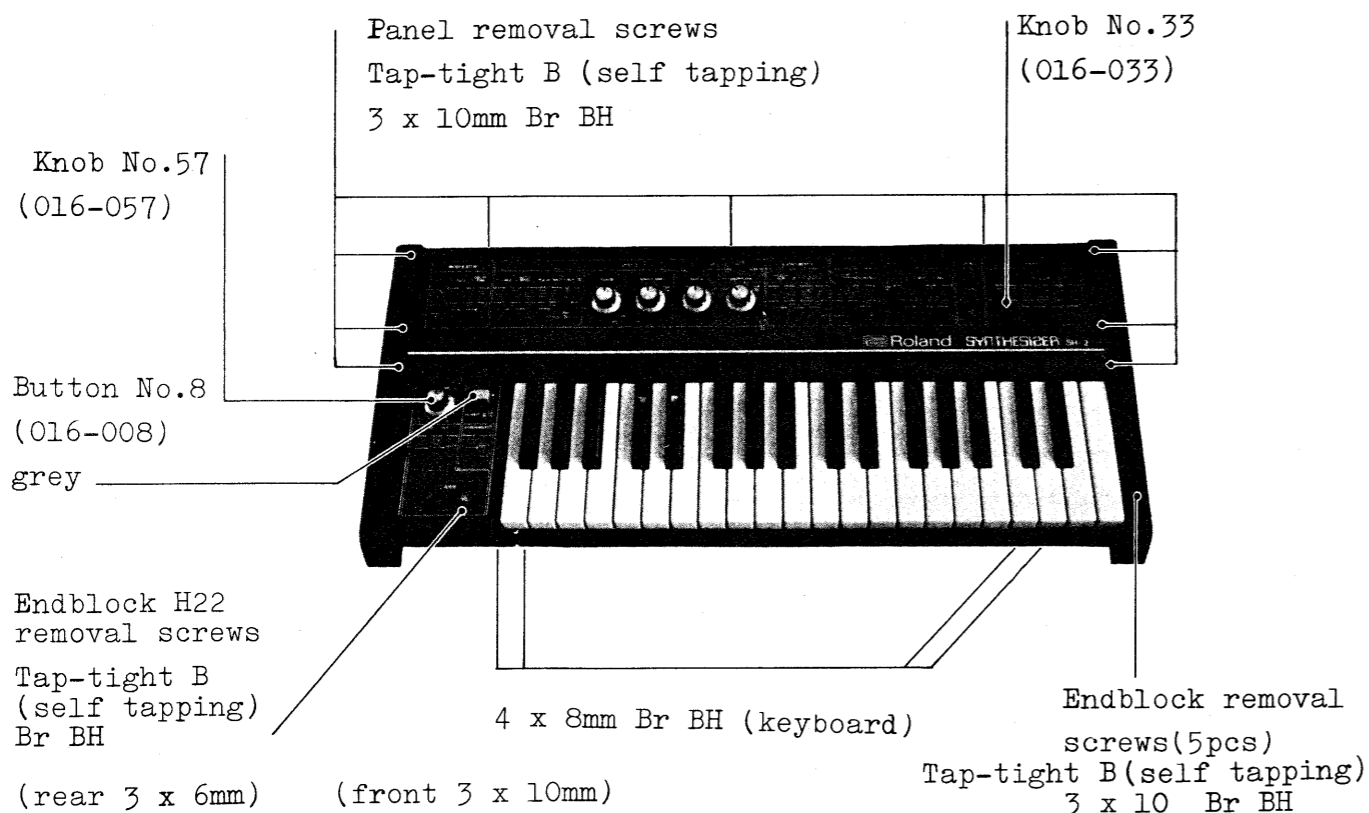
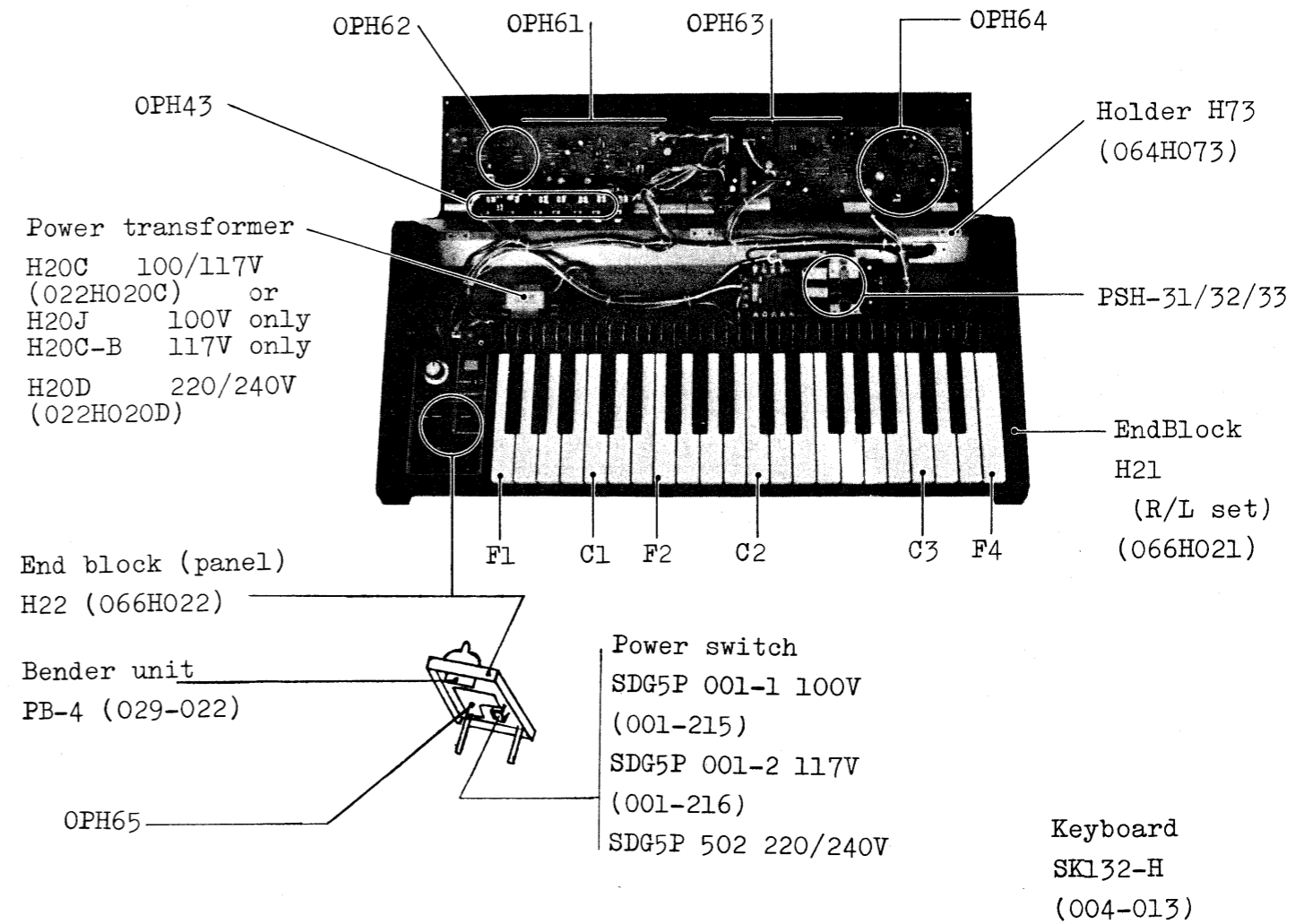

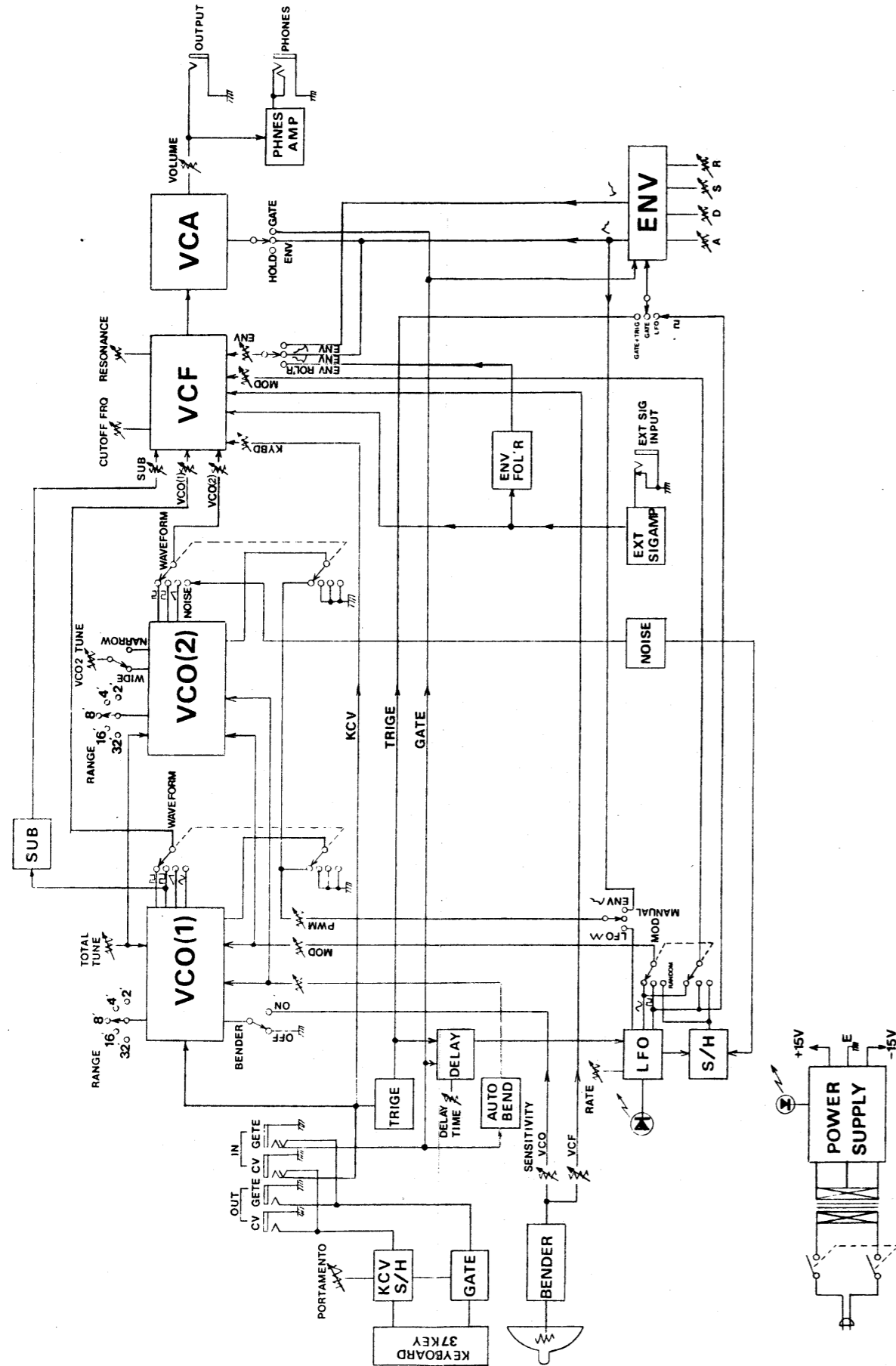

BLOCK DIAGRAM

KEYBOARD PARTS

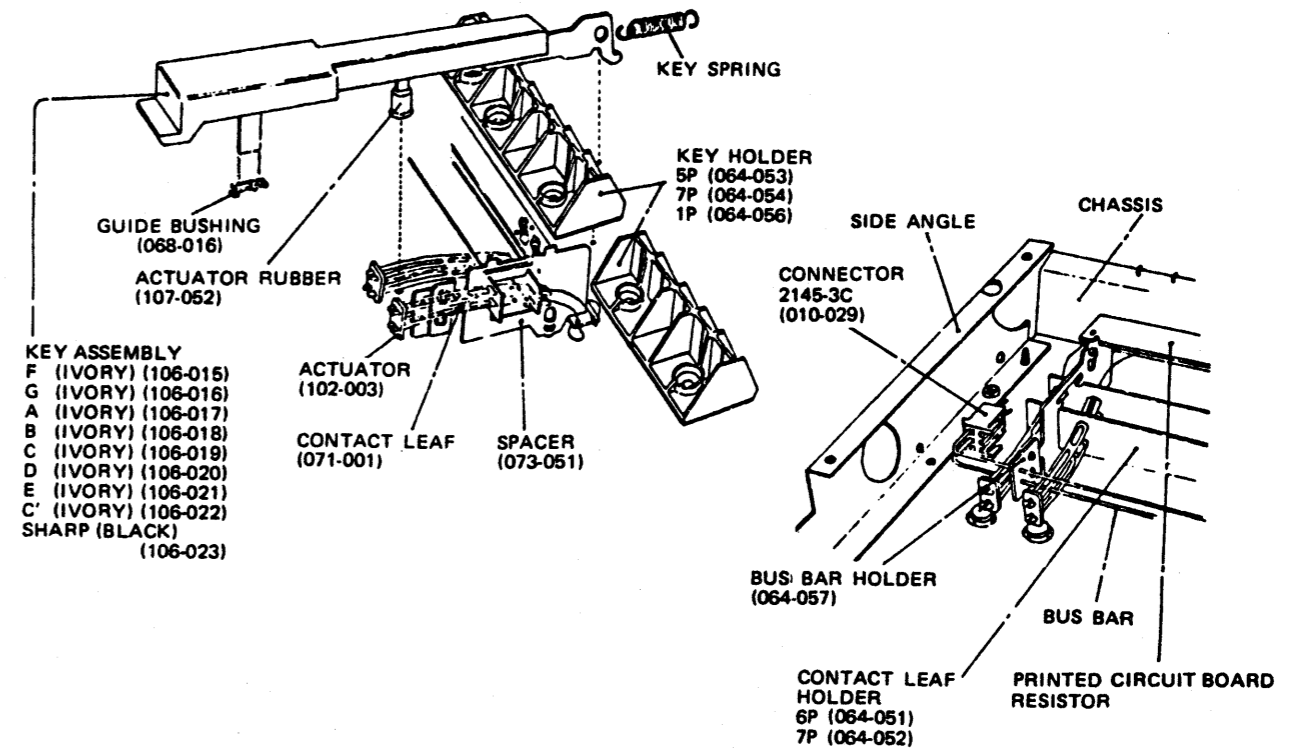

INSTRUMENT MODEL	NO. OF KEYS	KEYBOARD MODEL	KEY SPRING	BUS BAR	PCB		RESISTOR
					6P	7P	
SH-1	32	SK-132-D	070-052	071H034	052-066	052-067	100 1/4W $\pm 1\%$ CRB1/4FX
SH-3A	44	SK-142-A	070-052	071-008	052-066	052-067	100 1/4W $\pm 1\%$ CRB1/4FX
SH-5	44	SK-142-B	070-052	071-008	052-066	052-067	100 1/4W $\pm 1\%$ CRB1/4FX
SH-7	44	SK-142-C	070-052	071-008	052-066	052-067	100 1/4W $\pm 1\%$ CRB1/4FX
SH-2	37	SK132H	070-052	071-006	052-066	052-067	100 1/4W $\pm 1\%$ CRB1/4FX
SH-1000	37	SK-132-A	070-052	071-006	052-066	052-067	1K 1/4W $\pm 2\%$
SH-2000	37	SK-132-B	070-052	071-006	052-066	052-067	1K 1/4W $\pm 2\%$ SELECTED
VP-330	49	SK191-B	070-058	071H043	052-081	052-082	
SYSTEM-100	37	SK-132-C	070-052	071-006	052-066	052-067	100 1/4W $\pm 1\%$ CRB1/4FX
SYSTEM-700	61	SK-162-C	070-058	071-007	052-066	052-067	100 1/4W $\pm 1\%$ CRA1/4FX
RS-101	61	SK-161-A	070-058	071-007	052-081	052-082	
RS-202	61	SK-161-A	070-058	071-007	052-081	052-082	
RS-505	49	SK-192-A	070-058	071H043	052-081	052-082	
EP-10	61	SK-162-A	070-058	071-007			
EP-20	61	SK-162-A	070-058	071-007			
EP-30	61	SK-162B	070-058	071-007	052-081	052-082	

**PARTS LIST**

- 072H048 Panel H48
- 068-020 Bushing no.20
- 061H079 Chassis H79
- 111-021 Foot G-5 rear
- 111-023 Foot G-7 front
- 064H073A Holder H73A
- 066H022 Endblock H22 (panel), Bender
- 066H021 Endblock H21 R/L set
- 004-013 Keyboard SK132-H
- 016-057 Knob no.57 rotary
- 016-033 Knob no.33 slider
- 063-012 Strip no.12 knob no.33
- 016-008 Button no.8 grey power switch
- Power transformer
- 022H020C H20C 100/117V or
- 022H020J H20J 100V only
- 022H020C-B H20C-B 117V only
- 022H020D H20D 220/240V
- 009-012 Jack SG7622 no.8 PC type
- 009-036 Jack SG7713 no.8 stereo
- 008-029 Fuse MGP 0.25A CSA prim. 117V
- 008-060 Fuse SEMKO T250mA prim. 220/240V
- 008-059 Fuse SEMKO T200mA sec. 220/240V
- SWITCH
- 001-215 SDG5P001-1 100V
- 001-216 SDG5P001-2 117V
- 001-217 SDG5P 502 220/240V
- 001-234 SRM1034-K15 rotary 3p-4t
- 001-214 SRM1025-K15 rotary 2p-5t
- 001-182 SSB022-12PN slide 2p-2t
- 001-183 SSB023-12PN slide 2p-3t

PCB ASS'Y

- 149H061A OPH61A VCO VR board (PCB 052H176A-2)
- 149H062A OPH62A VCO (052H176A-1)
- 149H063A OPH63A VCF VR board (PCB 052H177A-2)
- 149H064A OPH64A VCF (052H177A-1)
- 149H043B OPH43B OUTPUT (052H150B)
- 149H065B OPH65B Bender (052H140B)
- 146H031A PSH31A Power supply 100V (PCB 052H139A)
- 146H032A PSH32A Power supply 117V
- 146H033A PSH33A Power Supply 220/240V

POTENTIOMETER

- Slider
- 029-306 LFE9RC16A15 100KA
- 029-317 LFE9RC16B15 100KB
- 029-319 LFE9RC16B55 500KB
- 029-308 LFE9RC16A55 500KA
- 029-309 LFE9RC16A16 1MA
- 029-575 EVALOPC15B16 100KB 20mm stroke
- 029-577 EVALOPC15A26 2MA 20mm stroke
- Rotary
- 030-951 EVHLWAD25B15 100KB TUNE
- 028-749 VM1ORK25A15 100KA VOL.

Trimmer

- 030-641 RJ6 202 2KB metal film
- 030-642 RJ6 502 5KB metal film
- 030-643 RJ6 103 10KB metal film
- 030-465 SR19R 10KB
- 030-469 SR19R 47KB
- 030-471 SR19R 100KB
- 029-022 Bender unit PB-4

SEMICONDUCTOR

- IC
- 020-097  $\mu$ PC4558C
- 020-100 TL082CP
- 020-039 DN819
- 020-032  $\mu$ A726HC
- 020-160 BA662A
- non BA662
- Factory selected for VCF.
- When replacing existing BA662, use one painted in the same color.
- 020-189 TA7140P
- 020-102 LF13741H
- 020-103 TA7179P

Transistor

- 017-097 2SA826-Q or 2SA733-P
- 017-118 2SC1740-Q or 2SC945-P
- 017-046 2SC828 NZ for noise
- 017-022 2SB434-0 or 2SB596-0
- 017-010 2SD234-0 or 2SD526-0
- 017-014 2SK30A-Y FET
- 017-016 2SK30A-GR FET

Diode

- 018-014 1S2473
- 018-015 SDT-1000 thermistor
- 018-078 1S2453 or 1SZ58 zener
- 018-089 1B4B41 stack
- 019-009 LR0601R LED red

CAPACITOR

- Electrolytic
- 032-275 ECEA25M4R7 4.7 mfd 25V MS-R type
- 032-190 ECEA 50N1 Bi-polar
- 032-191 ECEA 16N10 10 mfd 16V B-p.
- 035-279 ECQS1102K 1000pF 125V polystyren radial leads
- 035-091 ECQF 2334M 0.33 mfd polypropylene

WAFER TERMINAL

- 010-183 5045-03A w/friction lock
- 010-186 5045-05A
- 010-185 5045-07A

OTHERS

- 068-005 Bushing no.5 jack black
- 121-005 Washer no.5 jack
- 121-018 Washer no.18 jack red
- 048H001 Heat sink no.H1
- 012-003 Fuse clip TF758 or F-6
- 053H031 Flat cable H31

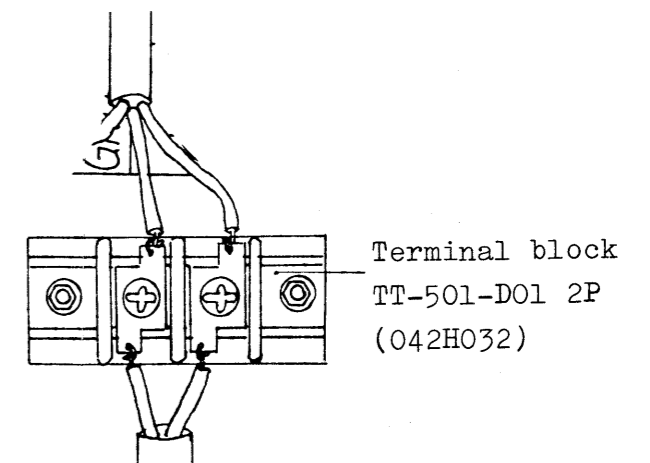
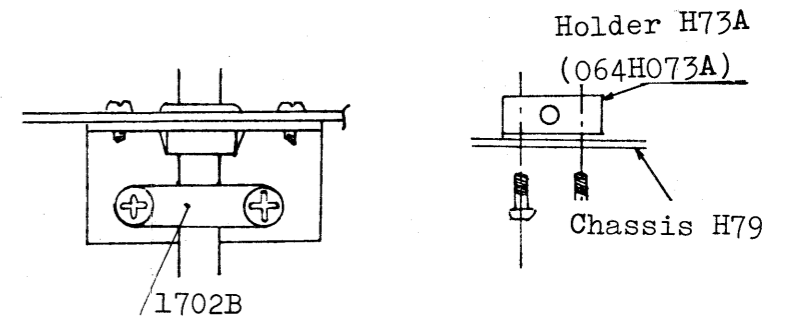
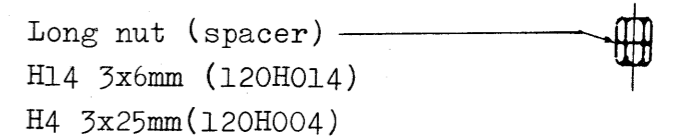
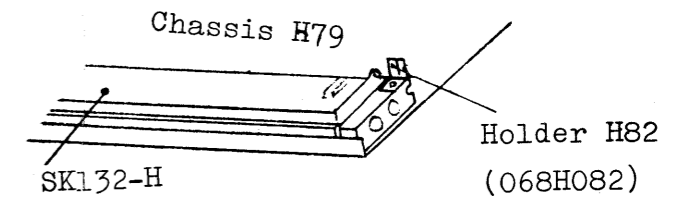

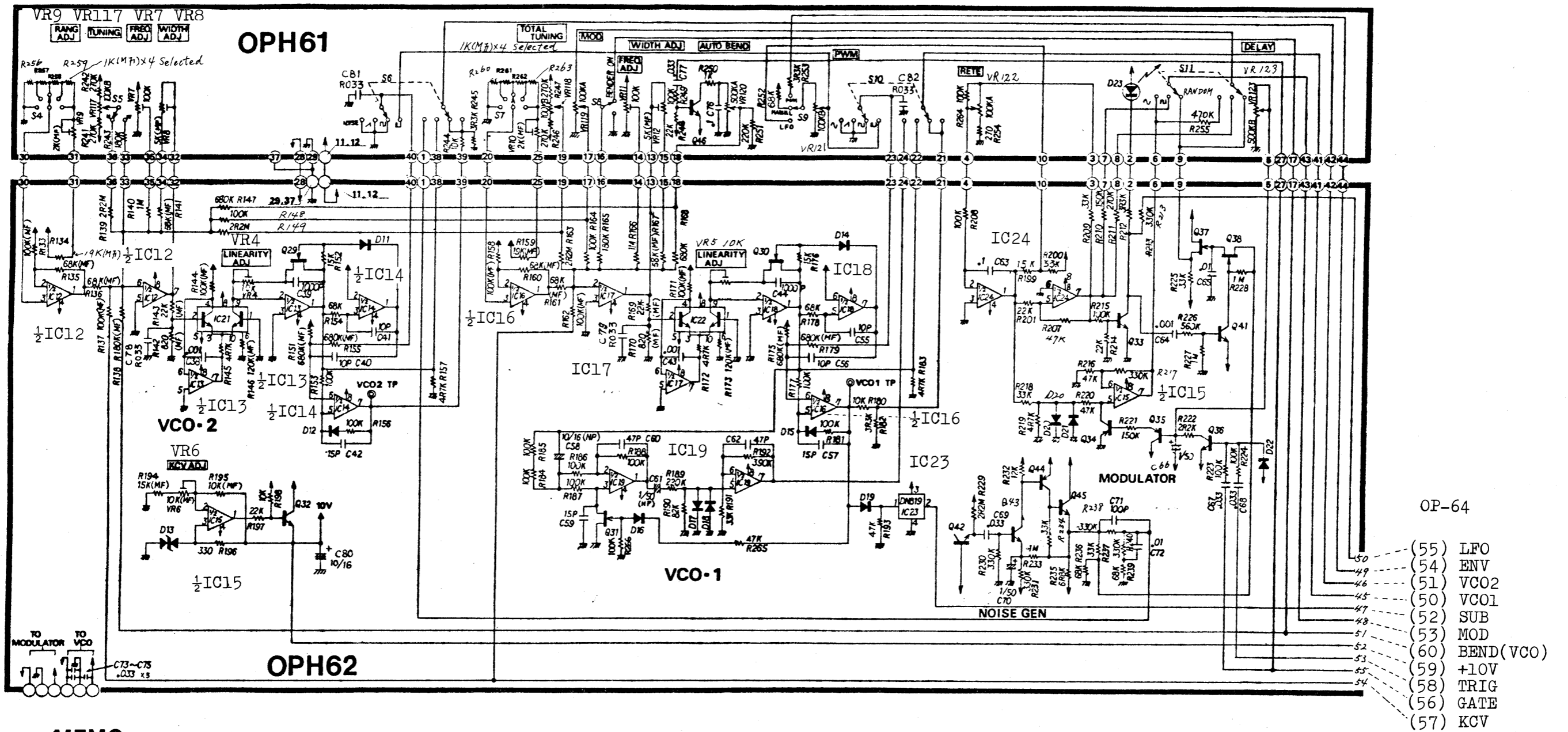

MEMO



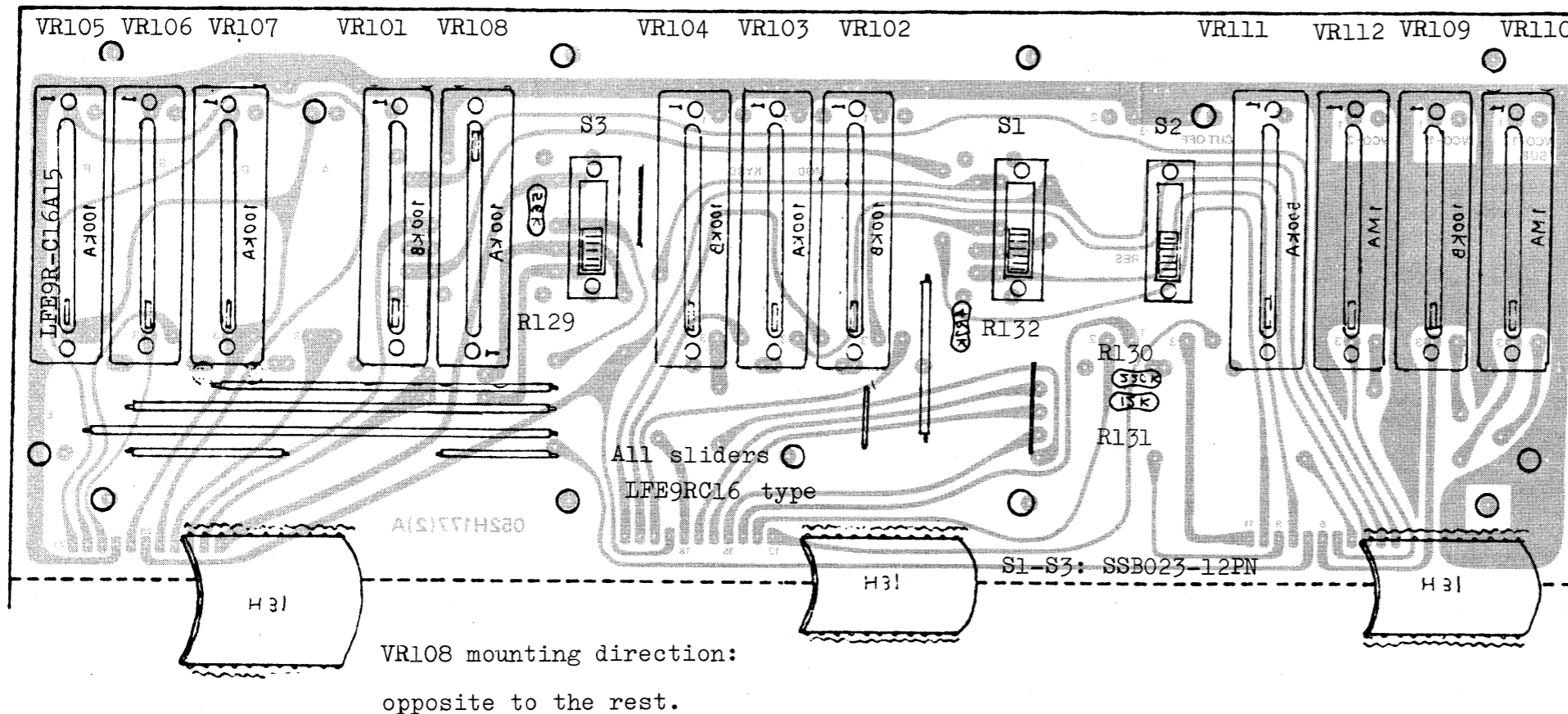

OPH63A 149H063A View from the foil side

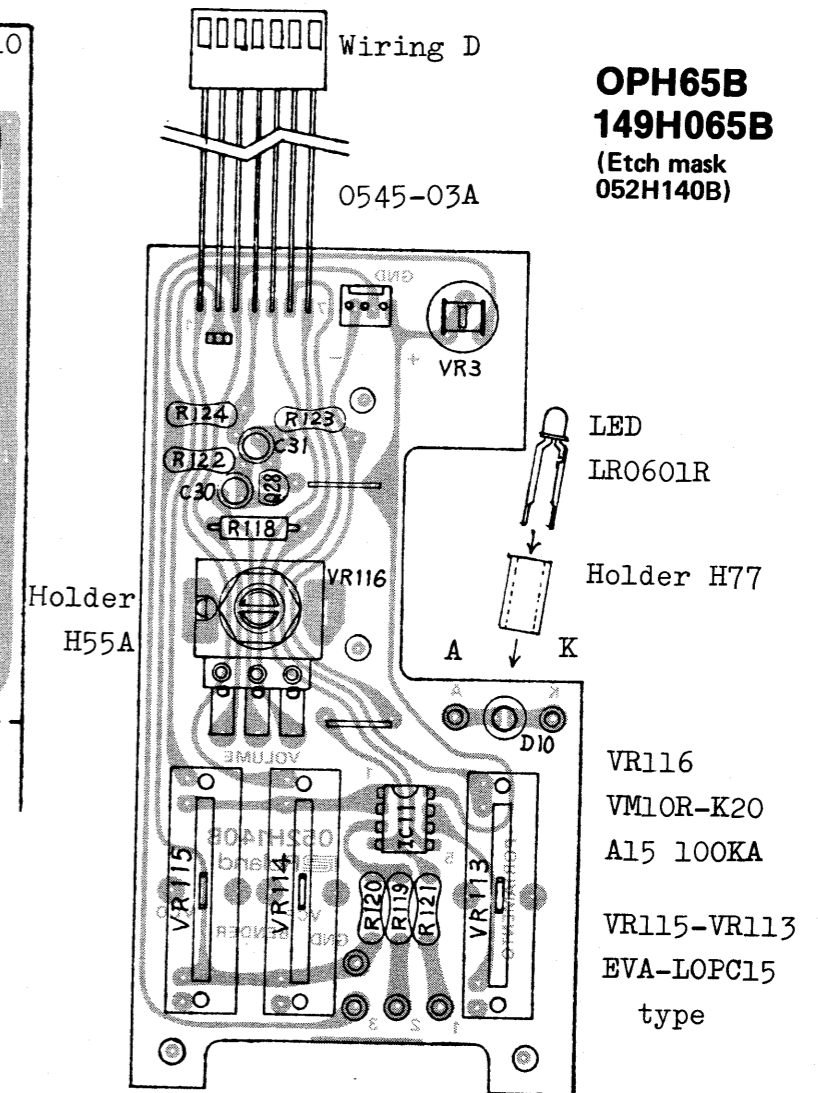

OPH65B 149H065B (Etch mask 052H140B)

Shield H58

OPH64A 149H064A (Etch mask 052H177A-1)

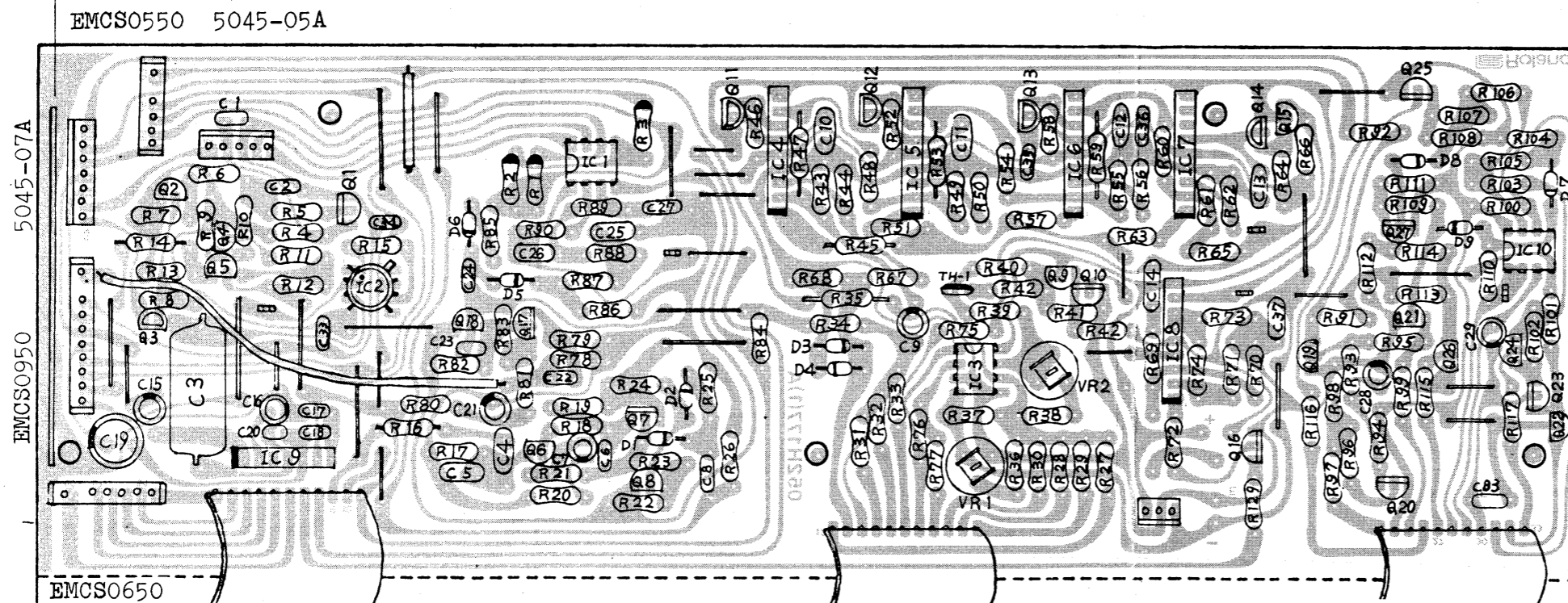

- D 2SK30A GR or Y
- D 2SA826-Q or 2SA733-P
- D 2SC1740-Q or 2SC945-P
- LS2473 or LS1555
- R-25J Carbon resistor
- Metal oxide film resistor CRB4FX
- SR19R

IC8 ----- BA662A  
 IC4-IC7 -- BA662 factory selected  
 When replacing IC4-7, use BA662 of the same color.

OPH43B 149H043B  
(Etch mask 052H150B)

SG7622 #08

SG7713 #08

SG7622 #08

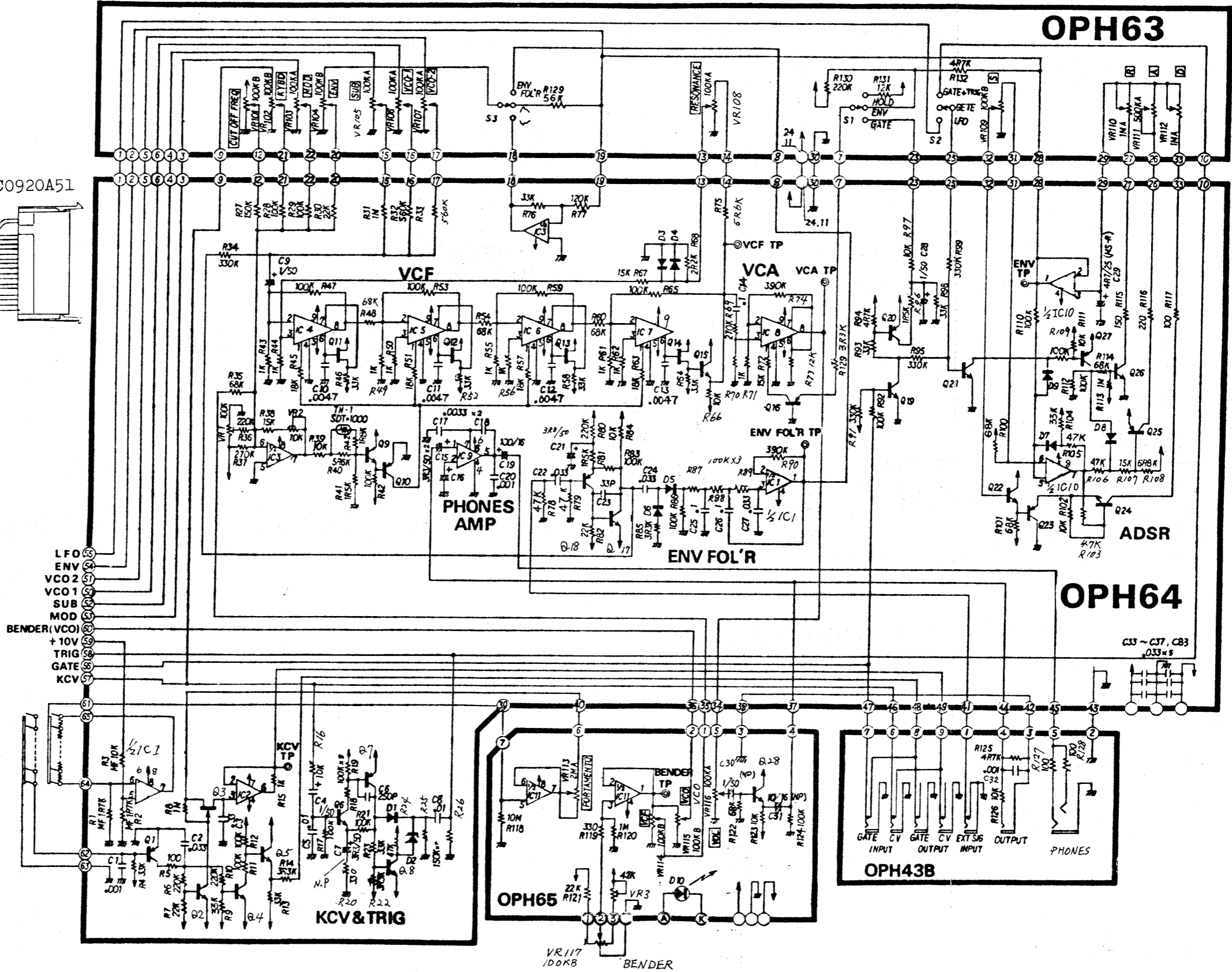
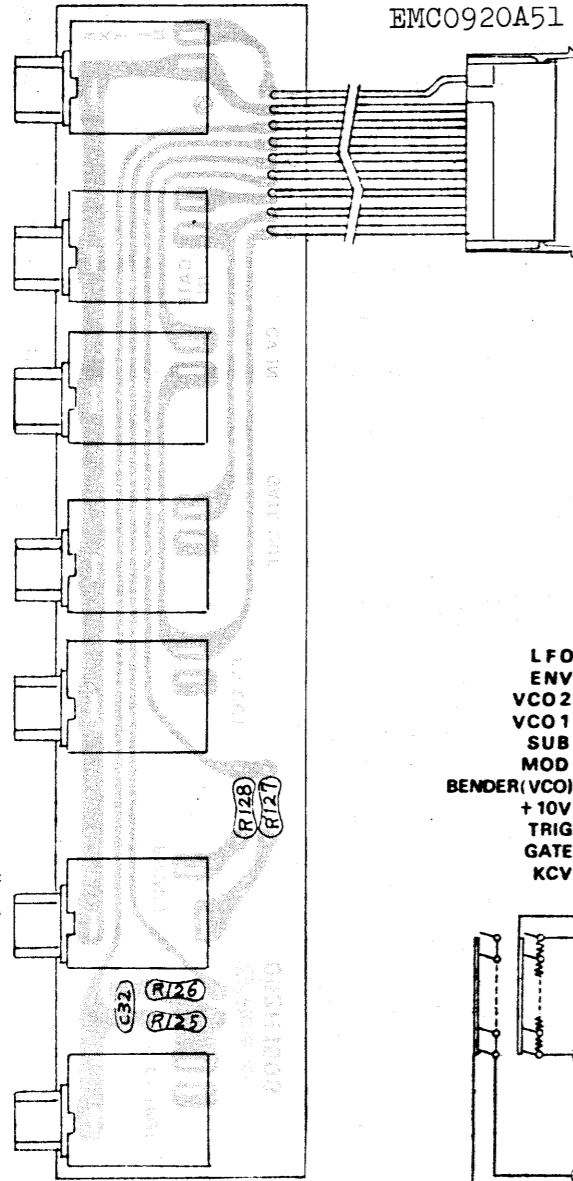

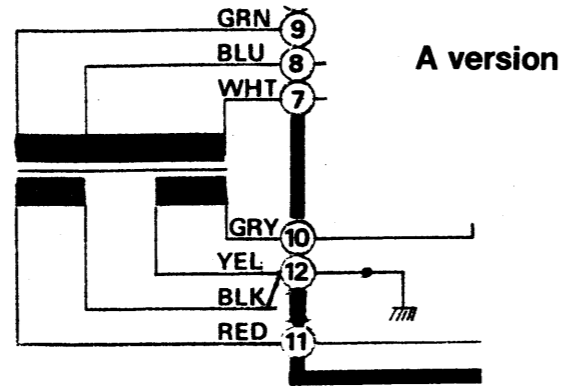
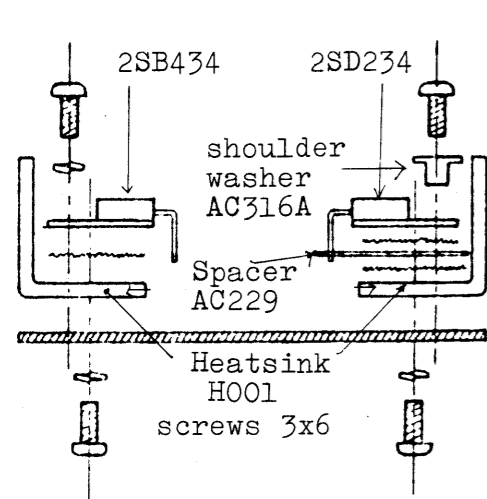

PSH-31/32/33 (for replacement, use A version)

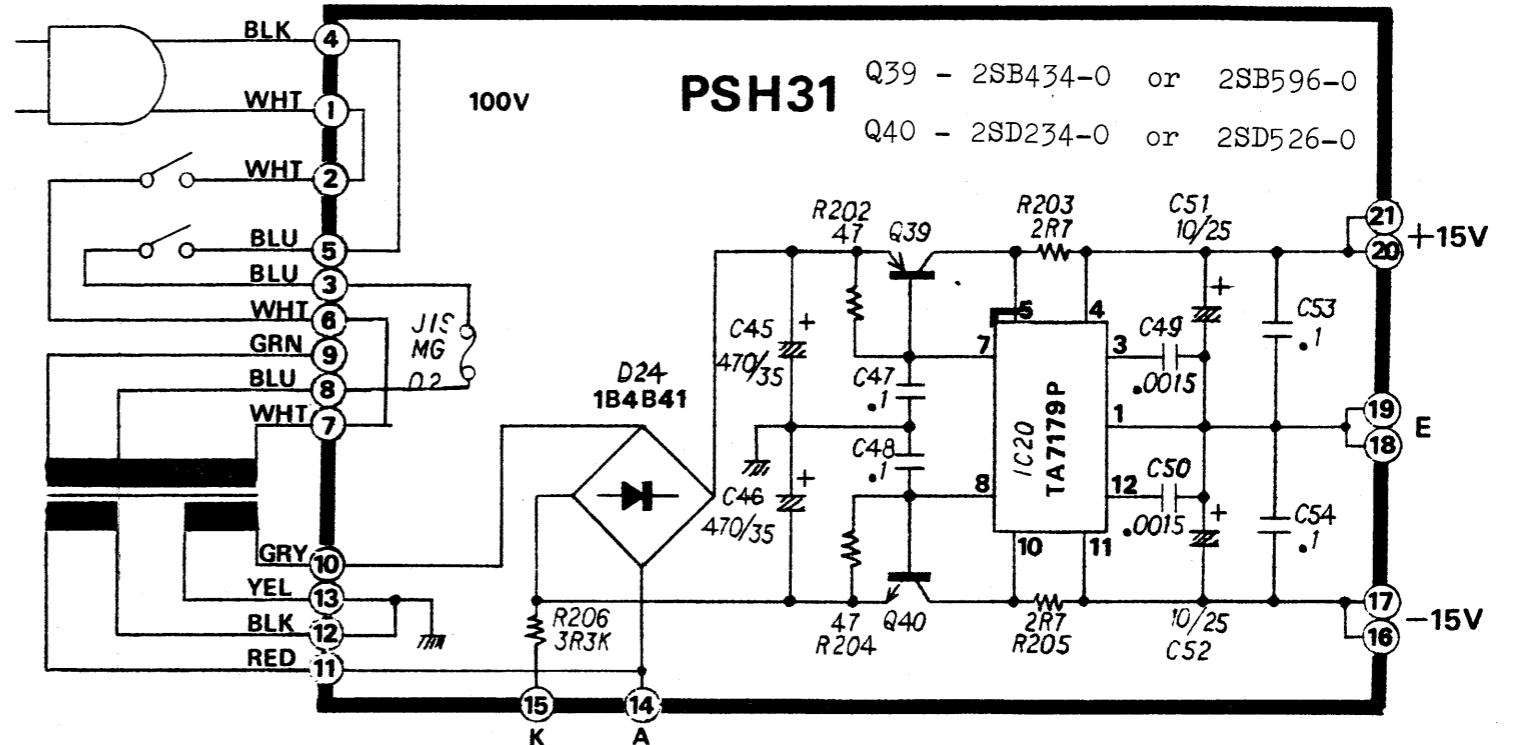
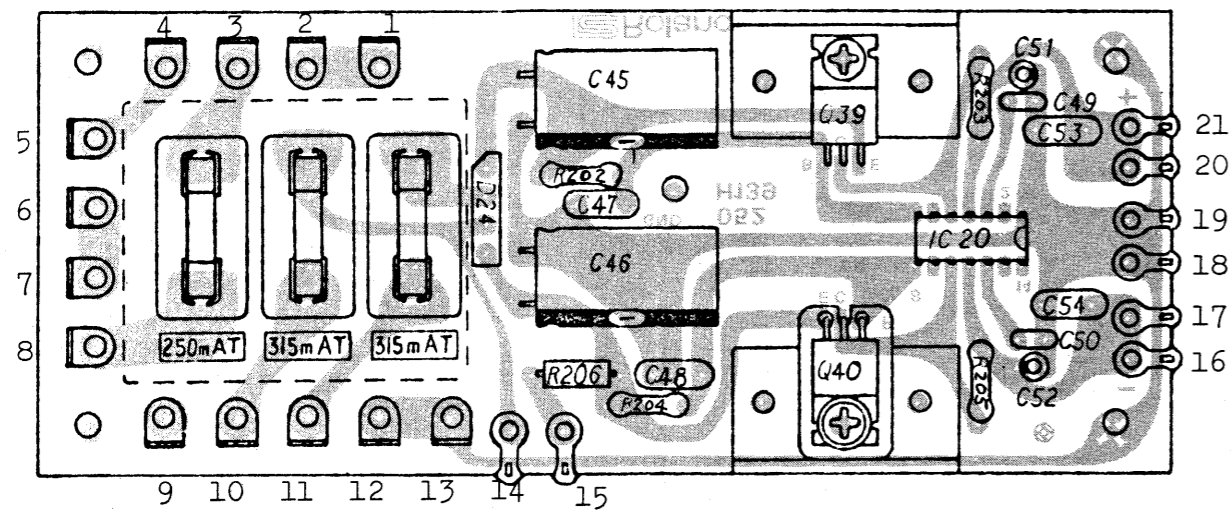

117V PSH32A

220/240V PSH33A

PSH31A 100V, PSH32A 117V, PSH33A 220/240V  
146H-31/32/33-A (Etch mask 052H139A)

Serial No. 830600 and higher

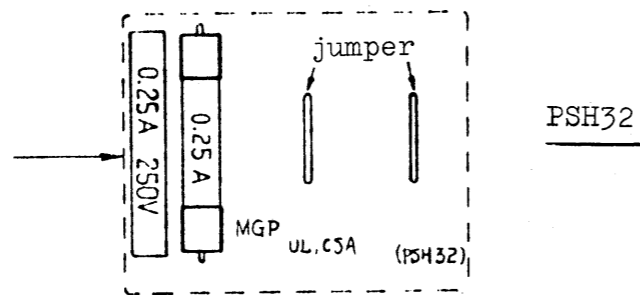
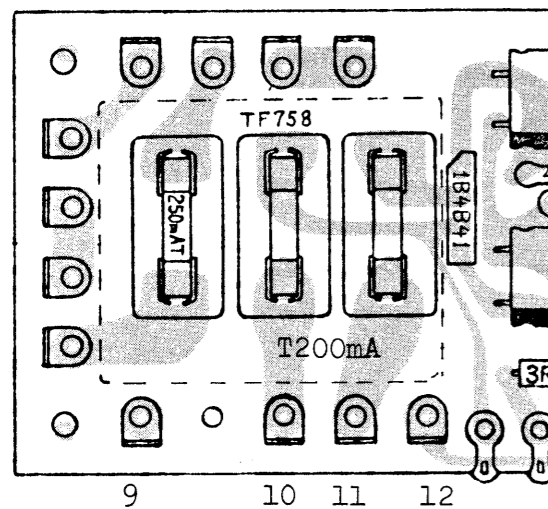

Terminals, nos.10-12 are different from preceider in location. The rest remains unchanged.

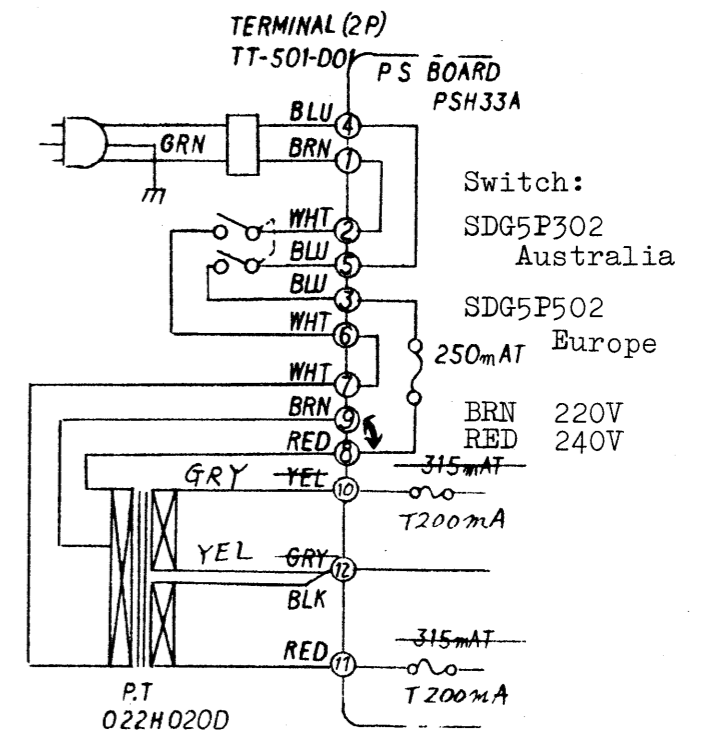
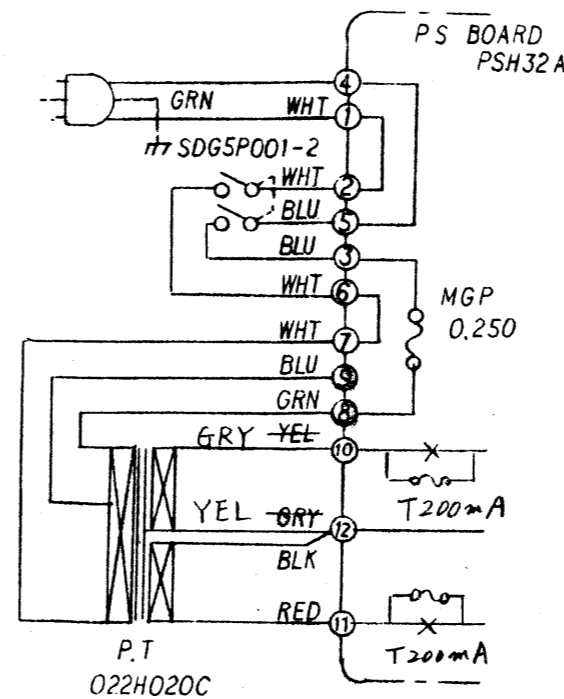



**ADJUSTMENT**

**BENDER**

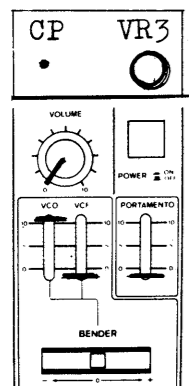

Connect a digital voltmeter to the TP on OPH65 shown in the figure left.

1. While pushing BENDER lever to the extreme left, note the reading on the meter.
2. While holding the lever at the extreme right, adjust VR3 for the reading equal to that of step 1.

Permissive voltage difference between the readings is  $\pm 30\text{mV}$ .

**KCV**

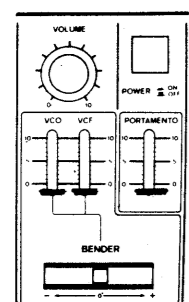

Shift the meter to the TP on OPH64 shown below.

1. While depressing F1 key, read the value of KCV on the meter. (For key designation, refer to page 1.)
2. While depressing F4 key, adjust VR6 for the reading 3V higher than that of step 1.

Make sure that F1, F2, F3 and F4 deliver 1V/1 oct voltages. Also voltage differences between every couple of octave keys must be within the range of  $1\text{V} \pm 2\text{mV}$ .

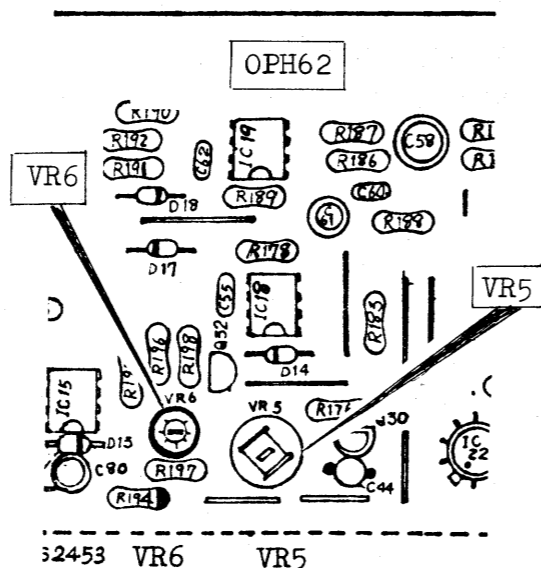
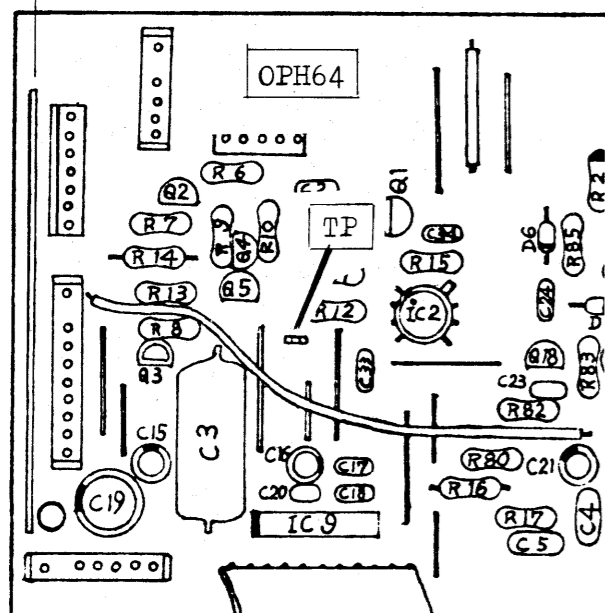

For the following tuning, use a completely tuned electronic instrument or a Tuning Meter. Adjustment can be made either beat sound method or by displaying Lisajous on an oscilloscope screen with a reference pitch being applied to EXT TRIG of the scope. For the latter, connect scope V IN to the TP on OPH64 shown in figure right.

**WIDTH**

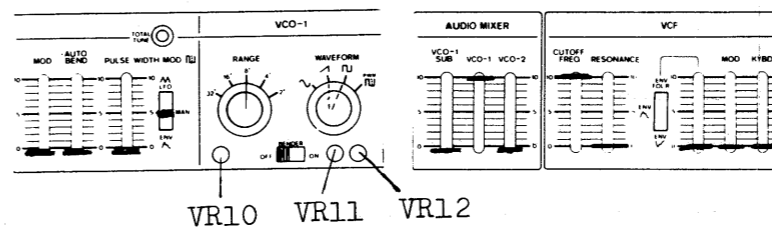

**Coarse**

1. While holding down F1 key, adjust VR11 (FREQ) for the pitch.
2. Tune other F's in the order F2, F3 and F4 by turning VR11 with corresponding key being held down.

**Fine**

1. With F1 key held down, turn VR12 (WIDTH) in the direction causing F1 further out of tuned, (do not attempt tuning F1 to the correct pitch at this step). Reverse rotation degree of VR12 should be proportional to F1 deviation from the reference pitch.
2. With F4 key down, tune F4 to the pitch with VR11.
3. Repeat steps 1 and 2 until all F's are correctly tuned. TOTAL TUNE knob can be the substitution for VR11.

**IMPORTANT:** Do not turn VR12 during subsequent adjustments. Turning VR12 will invalidate the entire VCO-1 adjustments.

**LINEARITY**

Set VCO-1 RANGE at 2'.

1. While depressing F1 key, tune F1 to pitch with TOTAL TUNE.
2. While depressing F3 key, adjust VR5 on OPH62 for the pitch.
3. Check all F keys for out of tune, if there any, repeat steps 2 and 3.

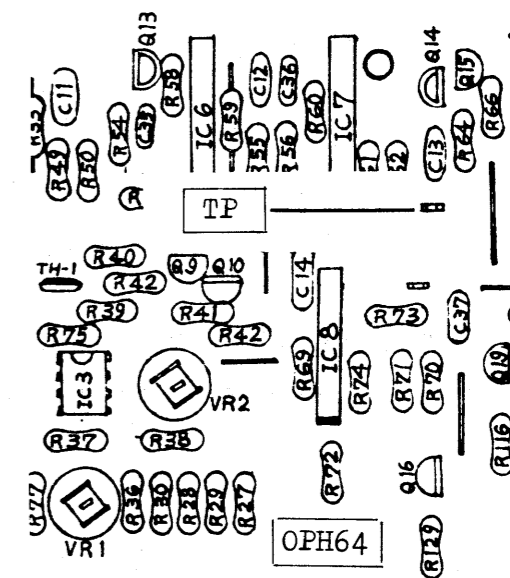

RANGE WIDTH

Set VCO-1 RANGE at 32'.

1. While holding down F1 key, adjust F1 for the pitch with TOTAL TUNE.
2. Place the RANGE at 2' and tune F1 to the pitch with VR10 (RANGE WIDTH).

FREQUENCY

Set VCO-1 RANGE at 8' and TOTAL TUNE at center of its travel range.

1. While depressing F1 key, adjust VR11 for F1 in tune.

VCO-2

WIDTH

(Being analogous to VCO-1 WIDTH Adjustment, refer to it for the detail.)

Coarse

1. With F1 key held down, adjust VR7 (FREQ) for pitch.
2. Tune F2, F3, F4 in sequence with VR7.

Fine

1. With F1 key down, turn VR8 (WIDTH) to cause F1 further out of tune.
2. With F4 key down, tune F4 to the pitch with VR7.  
(VCO-2 TUNE, VR117 may be used instead of VR7.)
3. Repeat steps 1 and 2.

Do not turn VR8 after WIDTH adj. Inadvertent turn of VR8 at the last minute of the VCO-2 adjustments will reduce VCO-2 circuit to non-adjusted condition.

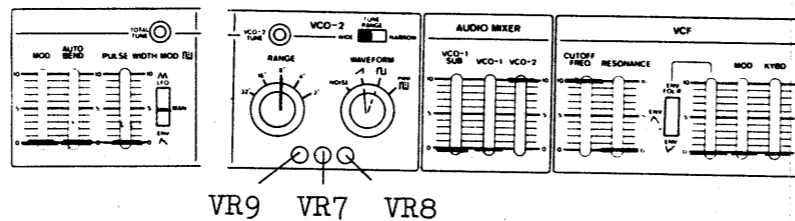

LINEARITY

Reset VCO-2 RANGE at 2'.

1. While depressing F1 key, tune F1 to the pitch with VCO-2 TUNE.

Set VCO-1 RANGE at 2' and raise VCO-1 knob on the panel (AUDIO MIXER) for a proper beat note volume.

2. While listening to the VCO -1 -2 beat sound, adjust VR4 (LINEARITY) on OPH62 for minimum beat repetition at F3 and F4 keys. (repeat steps 1 and 2)

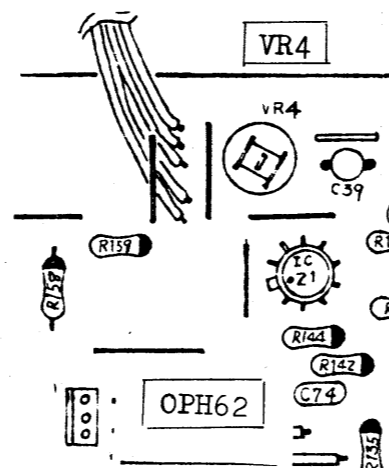

RANGE WIDTH

Reset VCO-2 RANGE at 32'. (AUDIO MIXER VCO-1 knob: at bottom)

1. Tune F1 to the pitch with VCO-2 TUNE knob.
- Reset VCO-2 RANGE at 2'. Slide up VCO-1 knob for a beat note.
2. While holding down F1 key, adjust VR9 (RANGE WIDTH) for minimum beat repetition.
  3. Repeat steps 2 and 3.

FREQUENCY

1. While switching TUNE RANGE on the panel -WIDE-NARROW-WIDE---- repeatedly, set VCO-2 TUNE at the point assuring the least pitch difference between the switch positions.
2. While depressing a key with TUNE RANGE set at NARROW, adjust VR7 to tune the note to the pitch.

VCF

Make sure that VCF starts and sustains oscillation at 7-9 RESONANCE scale.

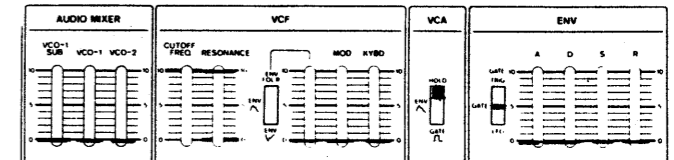

WIDTH

1. While depressing A2 key, tune the note to approx. 1kHz with CUTOFF FREQ knob. ( T=1ms )
2. Adjust VR2 (WIDTH) on OPH64 so that C1 and C2 keys develop VCF-generated notes having one octave relation with each other.

FREQUENCY

Slide up CUTOFF knob to the top.

1. while holding down F1 key, adjust VR1 for 20kHz.

Make it certain that low end key provides note less than 50Hz. Typically it is on 50Hz when C2 key is played with CUTOFF set at 0 (zero).

