

SYSTEM 100M SERVICE NOTES

First Edition

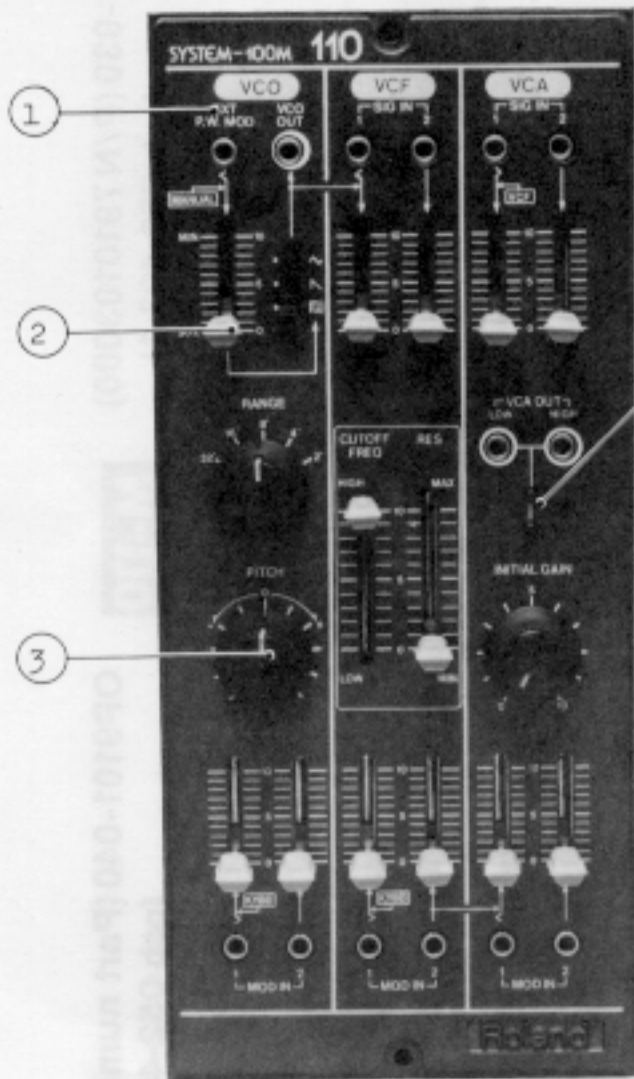

Pictures on this page represent parts common to modules and similarities.

For ①-④, see list at the right.

M-T	
	N-19
①	22210 19300
②	K 13
③	K 3
	G
④	1 G L - 1

- ① Knob N-127 (2247012700) M-131 M-182 only
- ② Self tapping screw 3 x 6mm Bl, Fe, Cm
- ③ Screw Binding head 3 x 6mm Fe, Cm
- ④ Holder N-189 (2219018900)

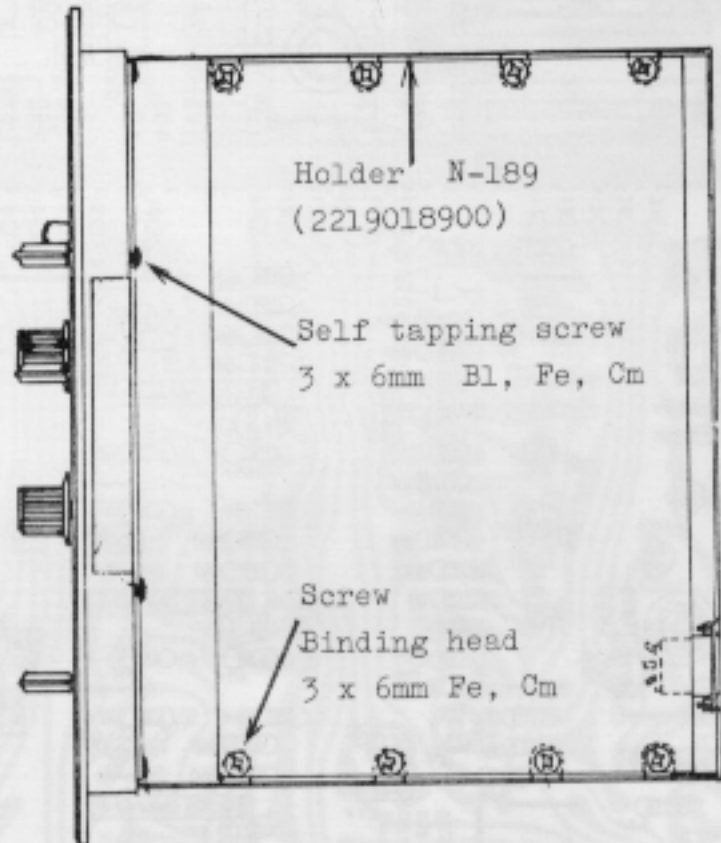

- Jack SC (009)
- Knob No. Pot. VMLORKL (028-7)
- Switch SLE-623 (131391)
- Pot. VMLORKL (028-75)

Cover N-122 (2201012200) Binding head 3 x 6mm Fe

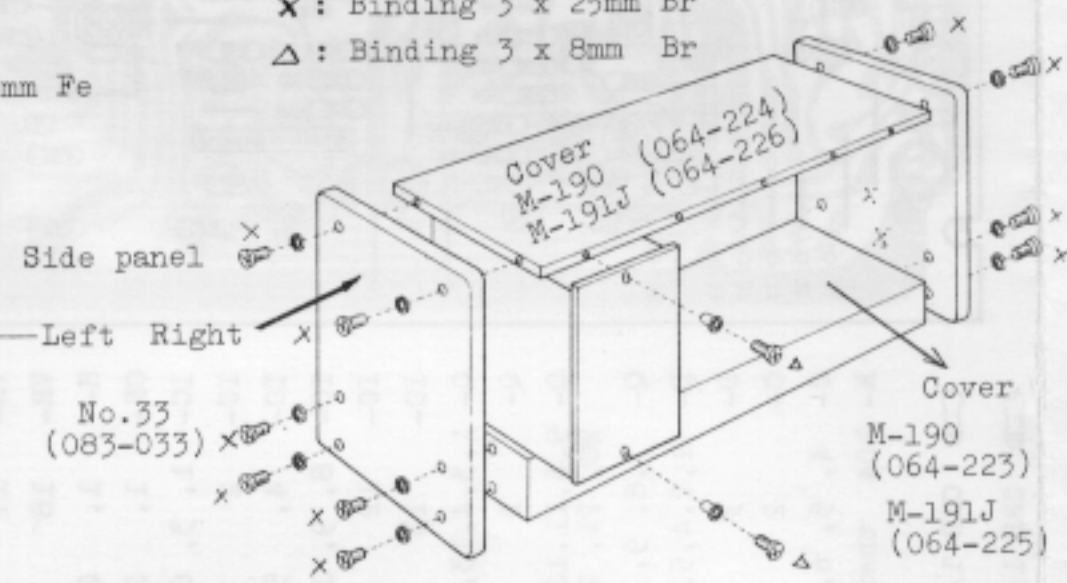

- Cabinet
- Jack DIN

- Twin pin jack P-254P-4 (009-016)
- DIN socket 8P CS0690-1-1 (13429603)
- Chassis M-190: No.222 (061-222) M-191J: No.221 (061-221)

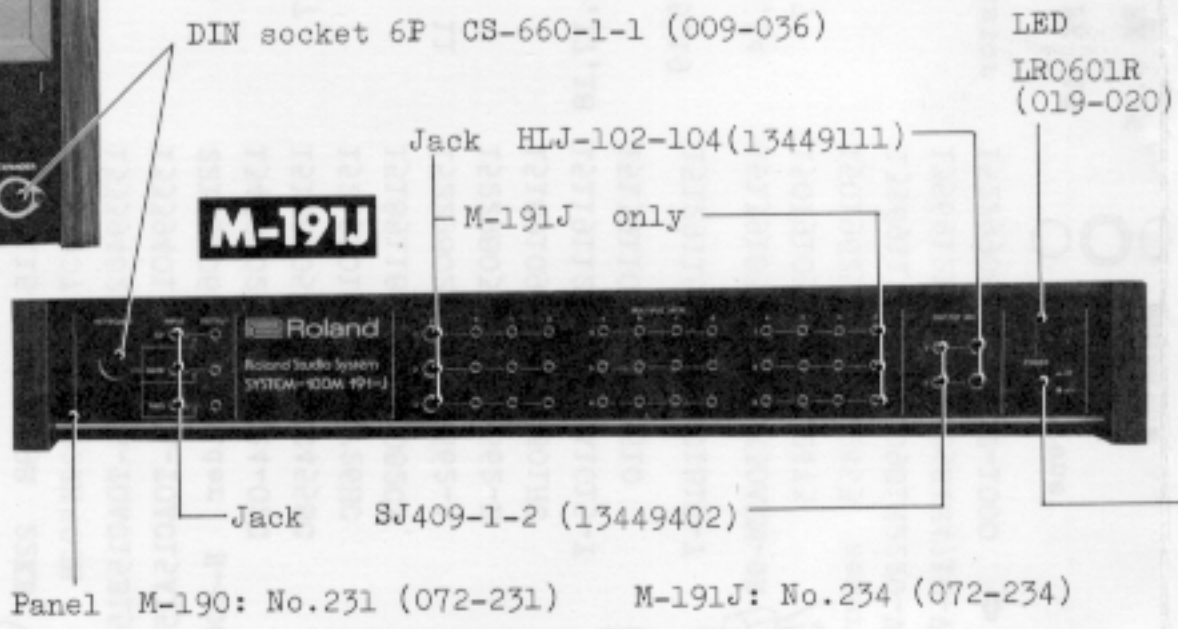

- Jack HLJ-102-104 (13449111)
- M-191J only
- Jack SJ409-1-2 (13449402)
- LED LRO601R (019-020)
- Panel M-190: No.231 (072-231) M-191J: No.234 (072-234)
- PB-4
- Power SDG5E SDG5E SDG5E

Parts are designated in New numbering (8-10 digits) and/or Old (6 digits).

"N" heading abbreviated new number stands for NEW.

When ordering replacement, use "No." for only old one.

Each figure, 0-13, at lower line in (2) - (4) indicates part per module.

	M-110	M-112	M-121	M-130	M-131	M-132	M-140	M-150	M-172	M-182
①	N-193 22210-19300	N-195 22210-19500	N-197 22210-19700	N-198 22210-19800	N-199 22210-19900	N-200 22210-20000	N-201 22210-20100	N-203 22210-20300	N-204 22210-20400	N-205 22210-20500
②	K n o b		N o .		7 9		0 1 6 - 0 7 9		2 2 4 7 0 1 2 9 0 0 N - 1 2 9	
	13	10	16	12	4	10	10	4	0	0
③	K n o b		N o .		7 8		0 1 6 - 0 7 8		2 2 4 7 0 1 2 8 0 0 N - 1 2 8	
	3	4	0	2	1	0	1	1	10	1
④	G L - 3 A R - 1 (red)		(0 1 9 - 0 2 2)		1 5 0 2 9 1 1 0		G L - 3 A R - 2 (red)			
	1	0	2	2	3	2	1	1	0 1 9 - 0 2 0	
	G L - 3 P G - 1 (green)		(019-023)		15029111				1 5 0 2 9 1 0 9	
	1	0	2	2	0	0	0	0	2	8

Jack SG-8050#4
(009-007)

Knob No.44 (016-044)
Pot.
VM10RK15B15(L)
(028-727)

Switch
SLE-623-12P(S)
(13139131)

Pot.
VM10RK15A26(L)
(028-756)

Removal screws

Top cover: 3.1 x 10mm wood, RH, Br
Cabinet (side): 3 x 25mm binding, Br
Cabinet (bottom): 4 x 15mm truss, Br

Top cover No.205 (065-205)

Cabinet No.122
(081-122)

Endblock No.242
(072-242)

Keyboard SK-132B
(004H006)

KEY ASSEMBLY
F (IVORY) (106-015)
G (IVORY) (106-016)
A (IVORY) (106-017)
B (IVORY) (106-018)
C (IVORY) (106-019)
D (IVORY) (106-020)
E (IVORY) (106-021)
F (IVORY) (106-022)
SHARP (BLACK) (106-023)

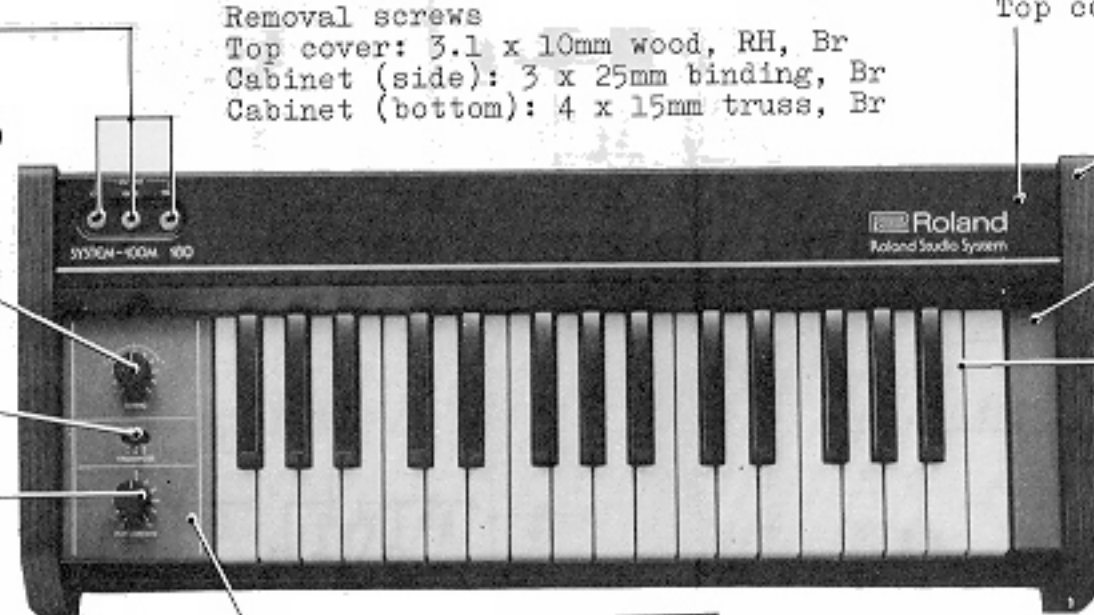

M-180

Cabinet No.155 (081-155)

Panel No.241
(072-241)

Base No.20 (foot)
(111-020)

Jack HLJ-102-R-4 (13449111)
DIN socket CS-660-1-1 6P (012-036)

Top cover No.206
(065-206)

M-181



Keyboard SK-192B (004H007)

Panel No.233 (072-233)

Switch SLE-622-12P(S) (13139130)

PB-4 (029-022)

Power switch

SDG5P-001-1 (13129101) 100V
SDG5P-001-2 (13129102) 117V
SDG5P-502 (13129103) 220/240V

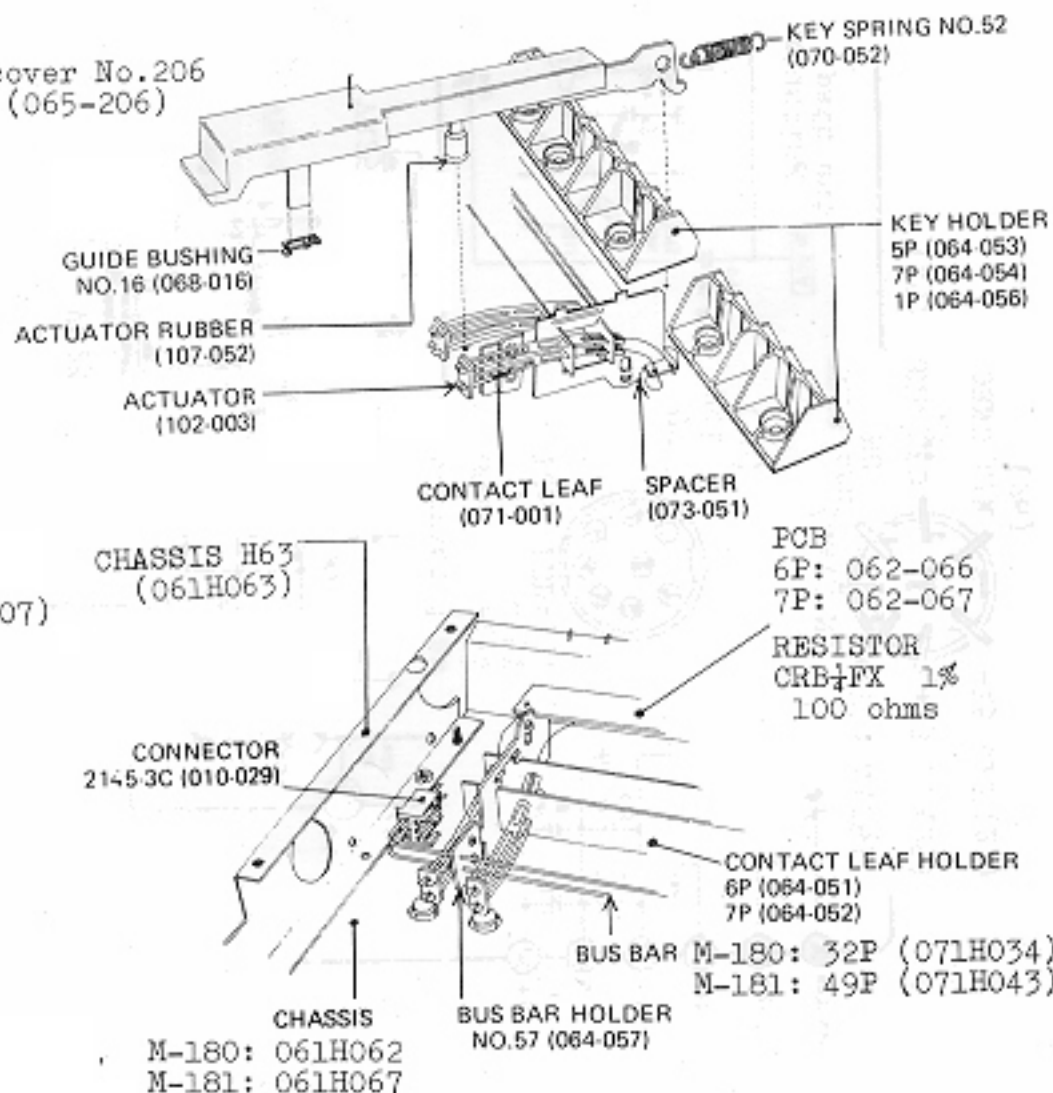

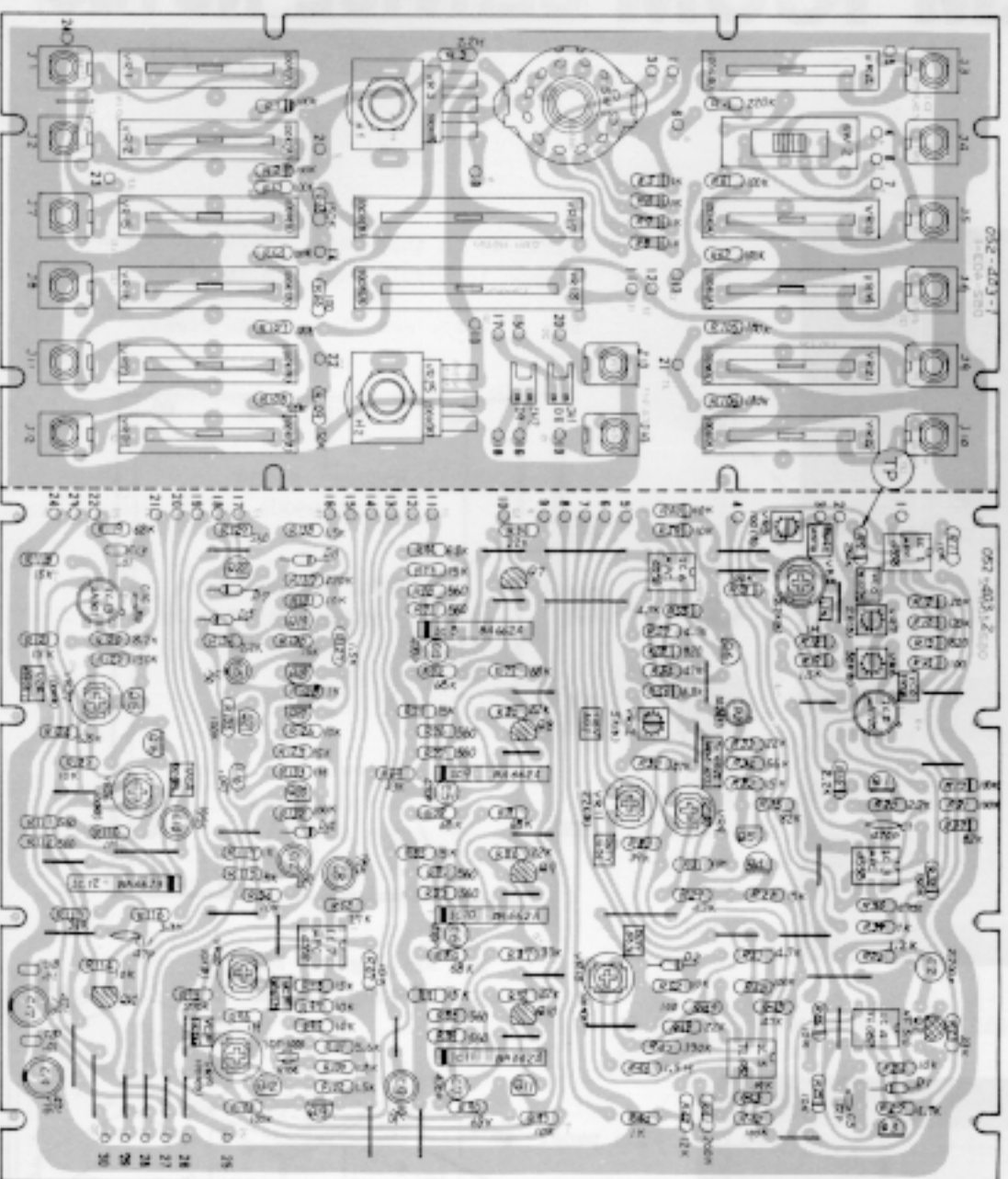
OP9101-030 (P/N 7910103000)
(pcb 052-403-1)**M-110**OP9101-040 (Part number 7910104000)
(pcb 052-403-2)

NONENCLATURE	PART NO.	MANUFACTURE NAME
J- 1-16	13449402	5J-409-1-2
SW- 1	13119401	SRM1025172
SW- 2	13159304	SSB02335
VR- 1,2,13,14,21,22	13339301	BVA-H04015A15
VR- 3, 25	13219220	VMI0RBL0C K20 100KB
VR- 4,15,16,23,24	13339304	BVA-H04015B15
VR- 5	13299501	EM822H101H
VR- 6	13299508	EM822H503H
VR- 7	13299504	EM822H202H
VR- 8	13299542	CR19R 2.2KB
VR- 9, 20	13299114	SR19R 10KB
VR- 10,19,26,27	13299117	SR19R 100KB
VR- 11	13299115	SR19R 22KB
VR- 12	13299507	EM822H502H
VR- 17	13339402	BVA-TOAC15B15
VR- 18	13339401	EVA-TOAC15A15
H- 1, 2	2219510600	Holder N-106
CN- 1, 2	13439502	3024-02C
IC- 1, 3, 6, 7	15189105	uPC4558C
IC- 2	15219101	uA726HC
IC- 4, 5	15189118	T1082CP
IC- 8, 9, 10, 11	15229802	EA662-A
IC- 12	15229803	EA662-B
IC- 13	15189109	uA701HC
Q- 1,3,4,13,16,17,18	15119112	28A1015-Y
Q- 2	15139110	NF510
Q- 5,6,11,12,15,19	15129115	28C1815-Y
Q- 20, 21, 22	15139103	28K30A17M-GR
Q- 7,8, 9, 10,14	15019103	182473
D- 1,2,4,5,6,7	15019625	182453 zener
D- 3	13569117W0	0009S1H222G-V
C- 2	13569121T0	0009S1H471G-V
C- 4, 5, 6, 7	15229908	SMD-1000
R- 104 thermistor		

GRB 1/4 PX 1K
 GRB 1/4 PX 0.1K

polystyrene
 bi-polar tantalum

M-110 VCO-HOP-VCA

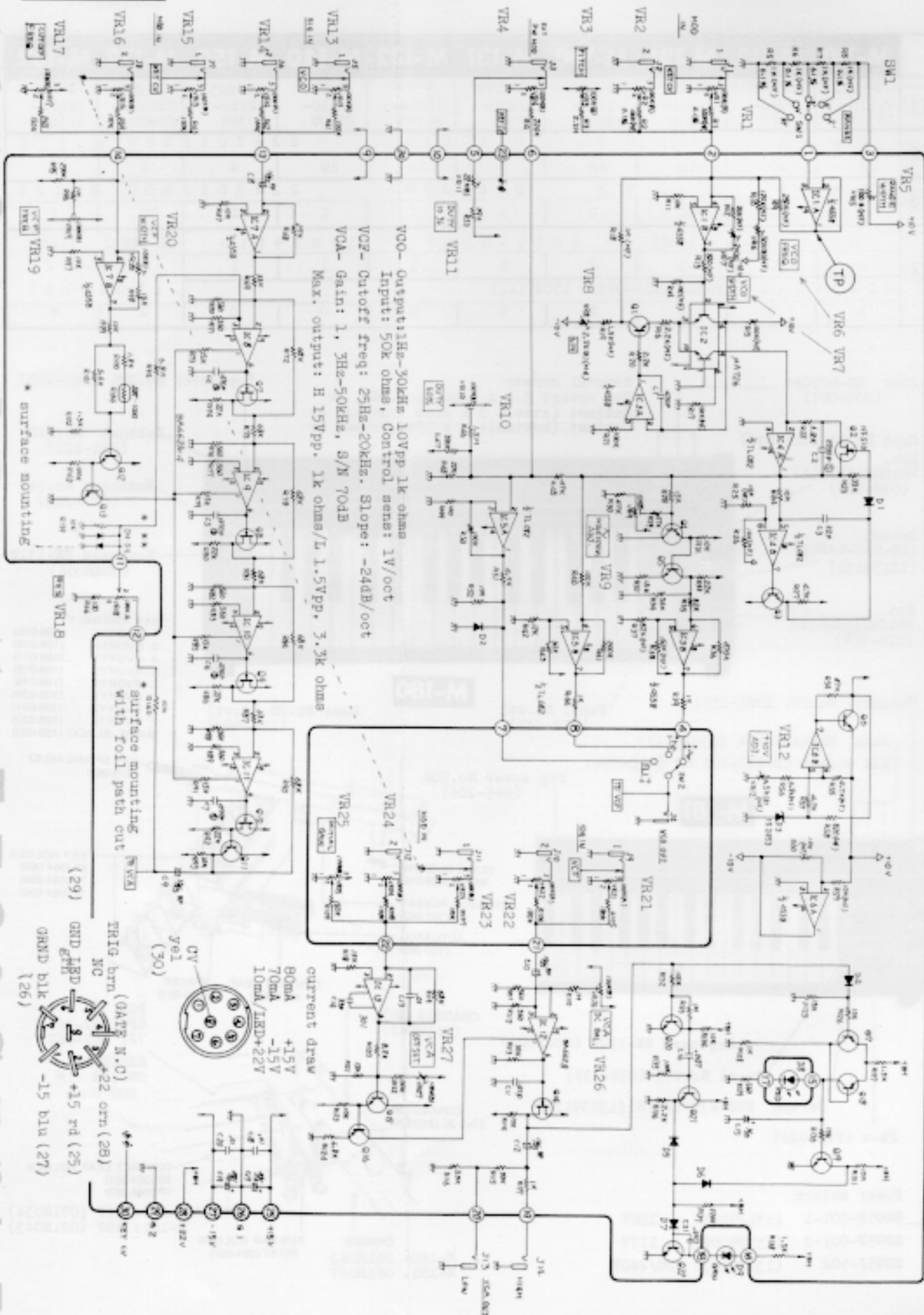

A B C D E F G H I J K L M N O P Q R S T U

1 2 3 4 5 6 7 8 9 10 11 12 13 14 15 16 17 18 19 20 21

OP9102-030 (P/N 7910203000)
M-112
OP9102-040 (Part number 7910204000)
(pcb 052-405-2)

Freq.: 1KHz-30KHz
Control Sens: 1V/oct

OP9102-030 (P/N 7910203000)
(pcb 052-405-1)

VCO output: 1k, 10V p-p
Input: 50k

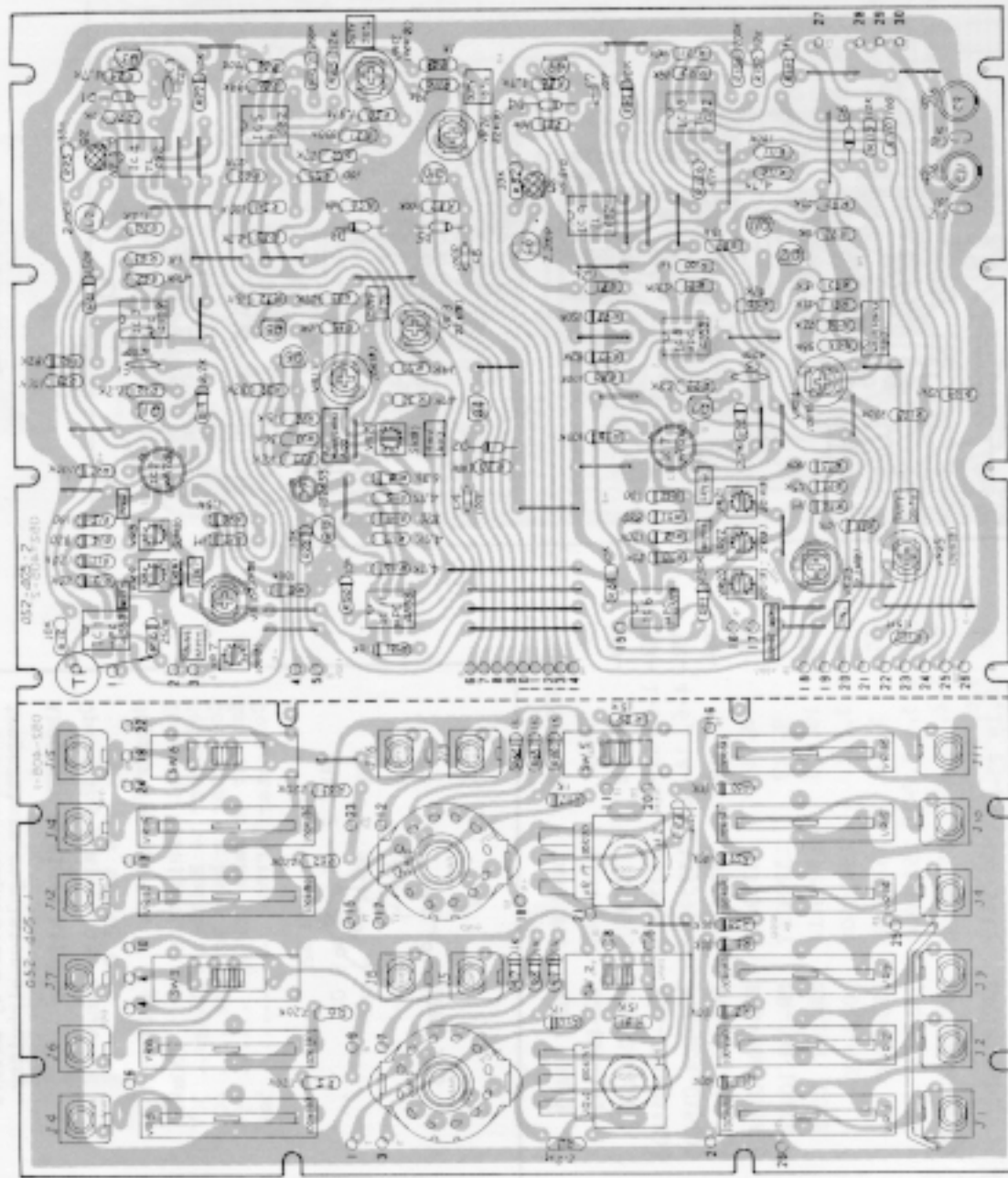

NOMENCLATURE	PART NO.	PART NAME
J- 1-16	13449402	SJ-409-1-2
SW- 1, 4	13119401	SWM-1025172
SW- 2, 5	13159103	SSB-02242
SW- 3, 6	13159304	SSB-02335
VR- 1-3, 14-16	13339301	EVA-H04C15A15
VR- 4, 17	13219220	VM10RB10C 100KB
VR- 5, 6, 18, 19	13339304	EVA-H04C15B15
VR- 7, 20	13299501	FM82-2H101H
VR- 8, 21	13299508	FM82-2H503H
VR- 9, 22	13299504	FM82-2H202H
VR- 10, 23	13299542	CR19R 2.2KB
VR- 11, 24	13299114	SR19R 10KB
VR- 12, 25	13299117	SR19R 100KB
VR- 13, 26	13299115	SR19R 22KB
VR- 27	13299507	FM82-2H502H
H- 1, 2	2219510600	Holder N-106
IC- 1, 3, 6, 8, 11	15189105	uPC4558C
IC- 2, 7	15219101	uA726HC
IC- 4, 5, 9, 10	15189118	TL082
Q- 1, 3, 5, 7, 9, 11	15119112	2SA1015-Y
Q- 2, 8	15139110	NP510
Q- 4, 6, 10, 12, 13	15129115	28C1815-Y
D- 1, 2, 3, 4, 5, 6	15019103	182473
D- 7	15019625	182453
C- 2, 6	1356911770	CQ0981H2220-V polystyrene

metal film CRB 1/4FX 0.1% 28C-
metal film CRB 1/4FX 1% 28A-

TOP VIEW

- μPC4558C BP INPUT
- NJM4558 JFET INPUT
- TL082CP

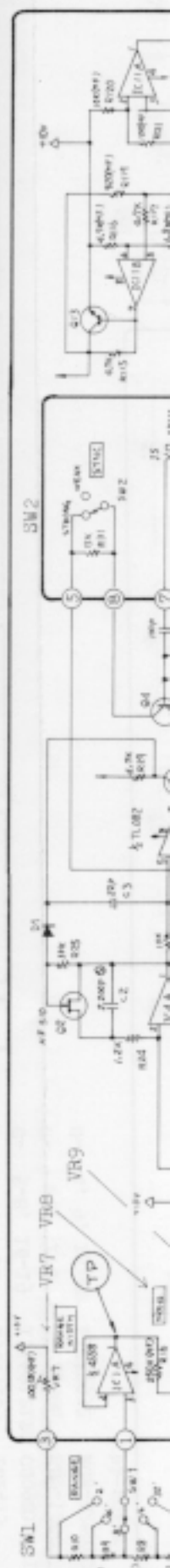

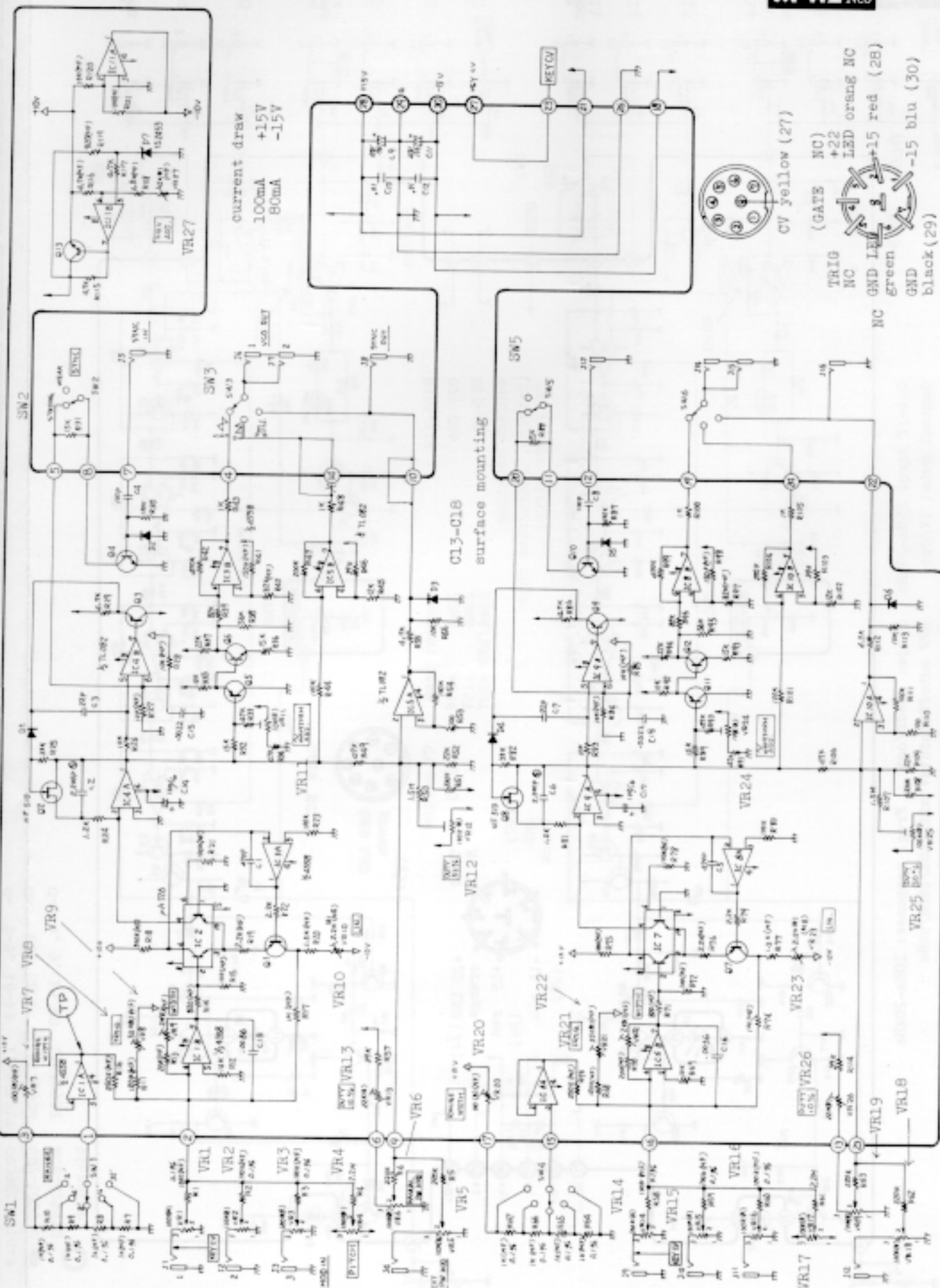

current draw
100mA +15V
80mA -15V



CV yellow (27)

(GATE NC)

TRIG NC

NC

GND LED

green

GND

black (29)

+22 LED orng NC

+15 red (28)

-15 blu (30)

1 2 3 4 5 6 7 8 9 10 11 12 13 14 15 16 17 18
A B C D E F G H I J K L M N O P Q R S T U

M-121 2V_{PP}

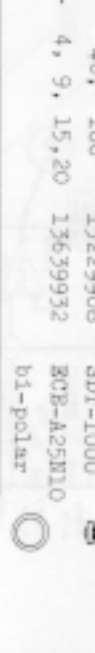
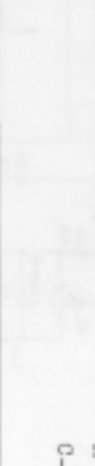
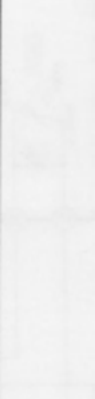
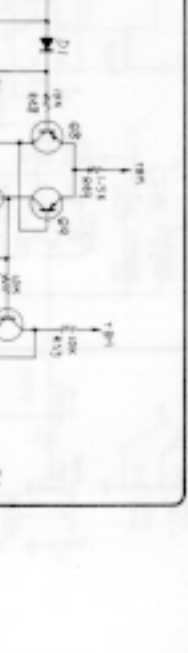
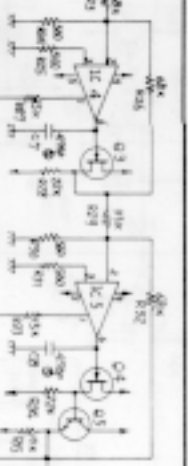
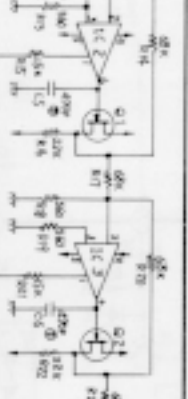
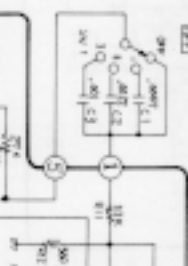
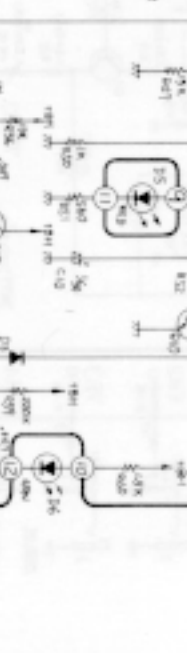
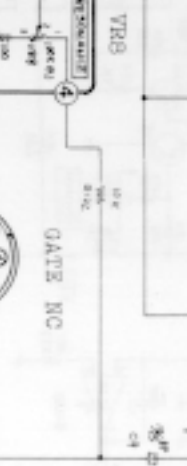
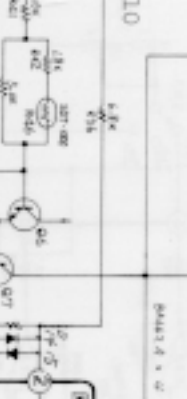
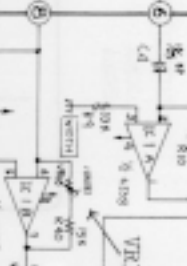
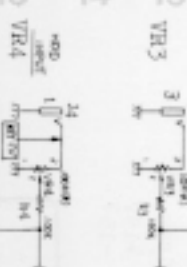
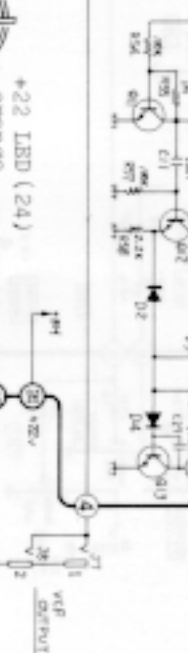
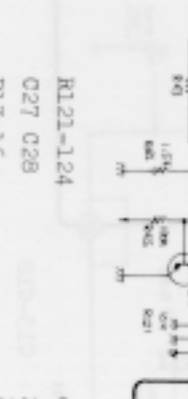
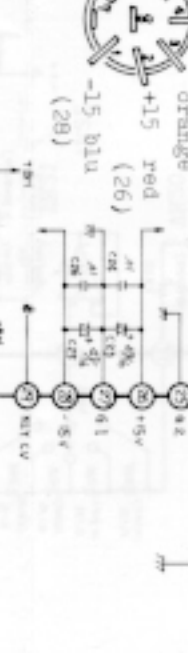
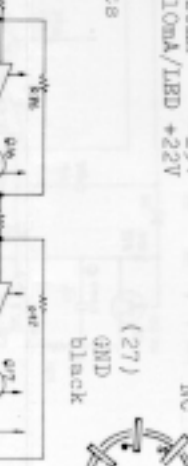
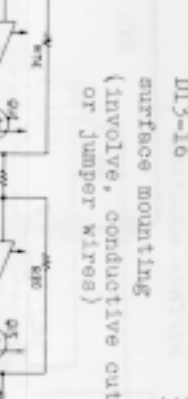
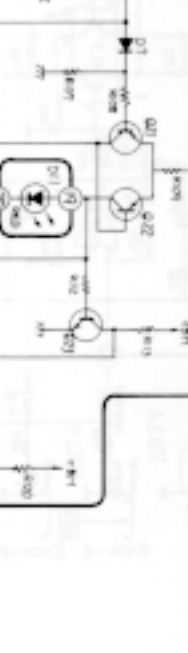
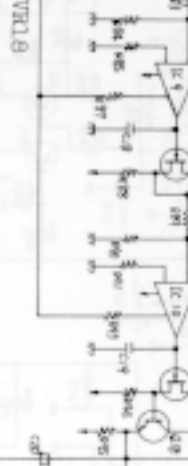
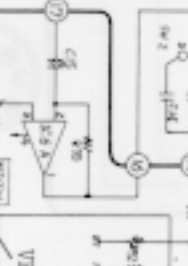
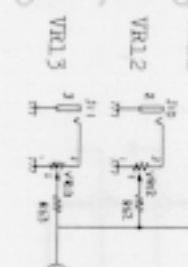
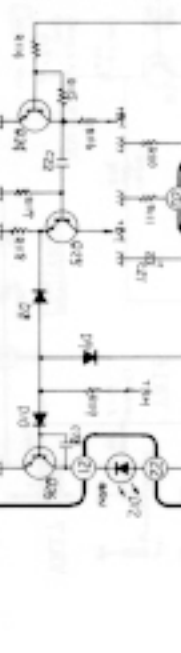
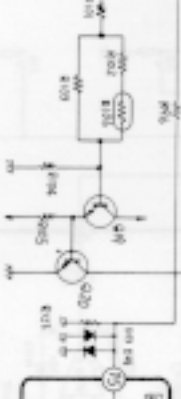
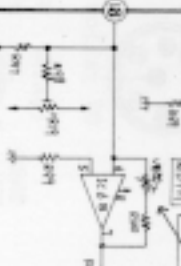
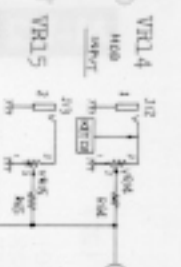
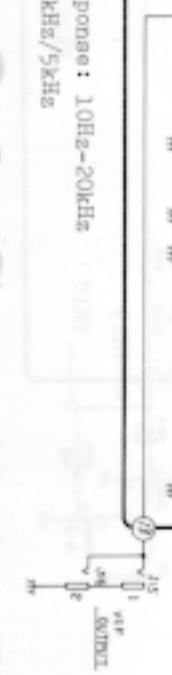
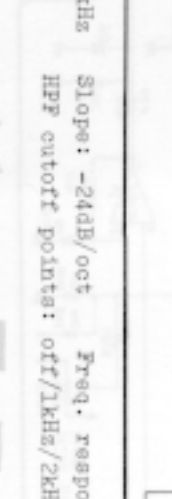
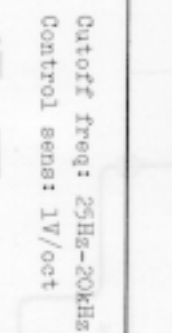
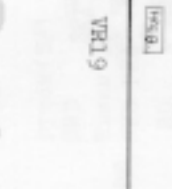
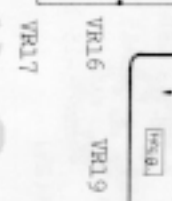
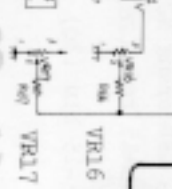

Cutoff freq: 25Hz-20KHz
Control sens: 1V/oct

Slope: -24dB/oct
HPF cutoff points: off/1KHz/2KHz/5KHz

freq. response: 10Hz-20KHz

surface mounting
(involve, conductive cuts
or jumper wires)

current draw
20mA +15V
20mA -15V
10mA/LBD +22V

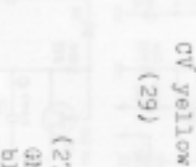

0- 4, 9, 15, 20 13639932
BOP-A25N10
b1-polar

OP9103-030(P/N 7910303000)
(pcb 052-407-1)

M-121

OP9103-040 (Part number 791030400)
(pcb 052-407-2)

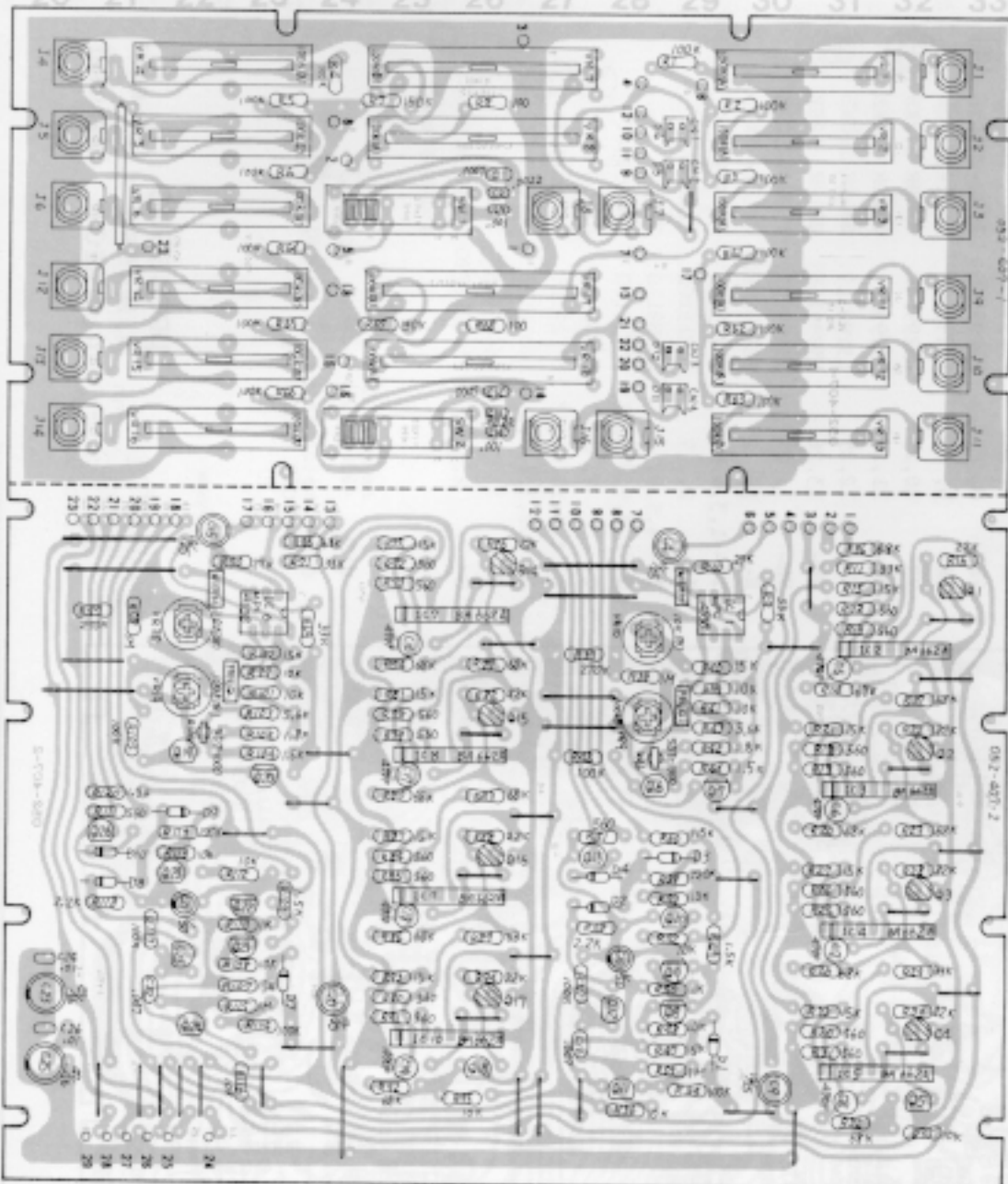

The transistor pair is held at a constant temperature by active temperature regulator circuitry.

JA726 M-110 M-112

ABSOLUTE MAXIMUM RATINGS

Operating Temperature Range
0° C to +85° C

Supply Voltage . . . ±18V

Internal Dissipation . . . 500mW

Collector to Emitter Voltage . . 30V

Collector to Base Voltage . . . 40V

Emitter to Base Voltage 5V

Collector Current 5mA



NOMENCLATURE	PART NO.	PART NAME
J- 1-16	13449402	SJ-409-1-2
SW- 1, 2	13159503	SQPR24-12P
VR- 1-3, 11-13	13339301	BVA-H04-015A15
VR- 4-6, 14-16	13339304	BVA-H04-015B15
VR- 7, 17	13339402	BVA-T0A-015B15
VR- 8, 18	13339401	BVA-T0A-015A15
VR- 9, 19	13299117	SR-19R 100KB
VR- 10, 20	13299114	SR-19R 10KB
CR- 1,2,3,4,	13439502	3024-020
IC- 1, 6	15189105	W3045580
IC- 2,3,4,5,7-10	15229802	HA662-A
Q- 1-4, 14-17	15139103	28K30ATH-GR
Q- 5,6, 10-13	15129115	2801815-Y
Q- 18,19 23-26	15119112	28A1015-Y
Q- 7-9, 20-22	15019103	182473
D- 1-4, 7-10	13569121T0	CQ0981H471G-V
O- 5-8, 16-19	15229908	SDT-1000
R- 46, 106	13639932	RCR-A25N10
C- 4, 9, 15, 20		

NOMENCLATURE	PART NO.	PART NAME
J- 1-16	13449402	8J-409-1-2
SW- 1, 2	13159103	8SB-022-42
VR- 1-3, 11-13	13339301	EVA-HO4-C15A15 100KA
VR- 4-6, 14-16	13339304	EVA-HO4-C15B15 100KB
VR- 7, 17	13219220	VM10RB10CK20 100KB
VR- 8, 10, 18, 20	13299117	SR19R 100KB trimmer
VR- 9, 19	13299115	SR19R 22KB
CN- 1-4	13439502	3024-02C
IC- 1, 2	15229803	BA662-B
IC- 3	15189105	uPC4558C
Q- 1, 12	15139103	28K30ATM-GR FBT
Q- 2, 4, 8-11	15129115	28C1815-Y
Q- 3, 5-7	15119112	28A1015-Y
D- 1-4, 7-10	15019103	182473
C- 10mfd/25V	13639932	Bi-polar ECR-A25N 

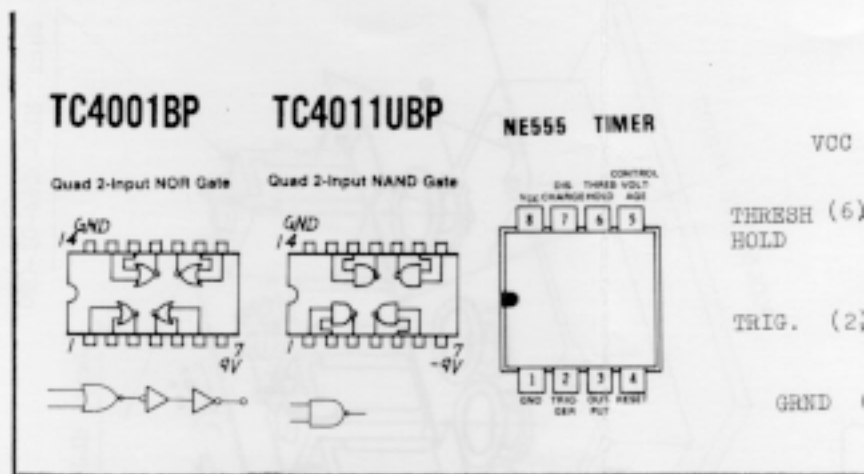

OP9104-030 (P/N 7910403000) **M-130** OP9104-040 (P/N 7910404000)
(pcb 052-408-1) (pcb 052-408-2)

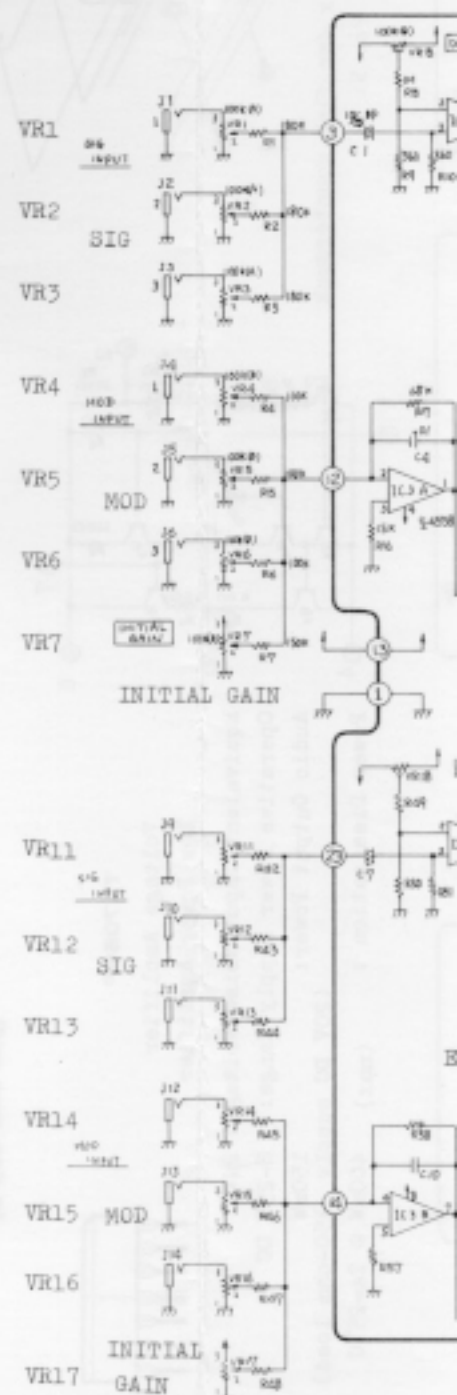
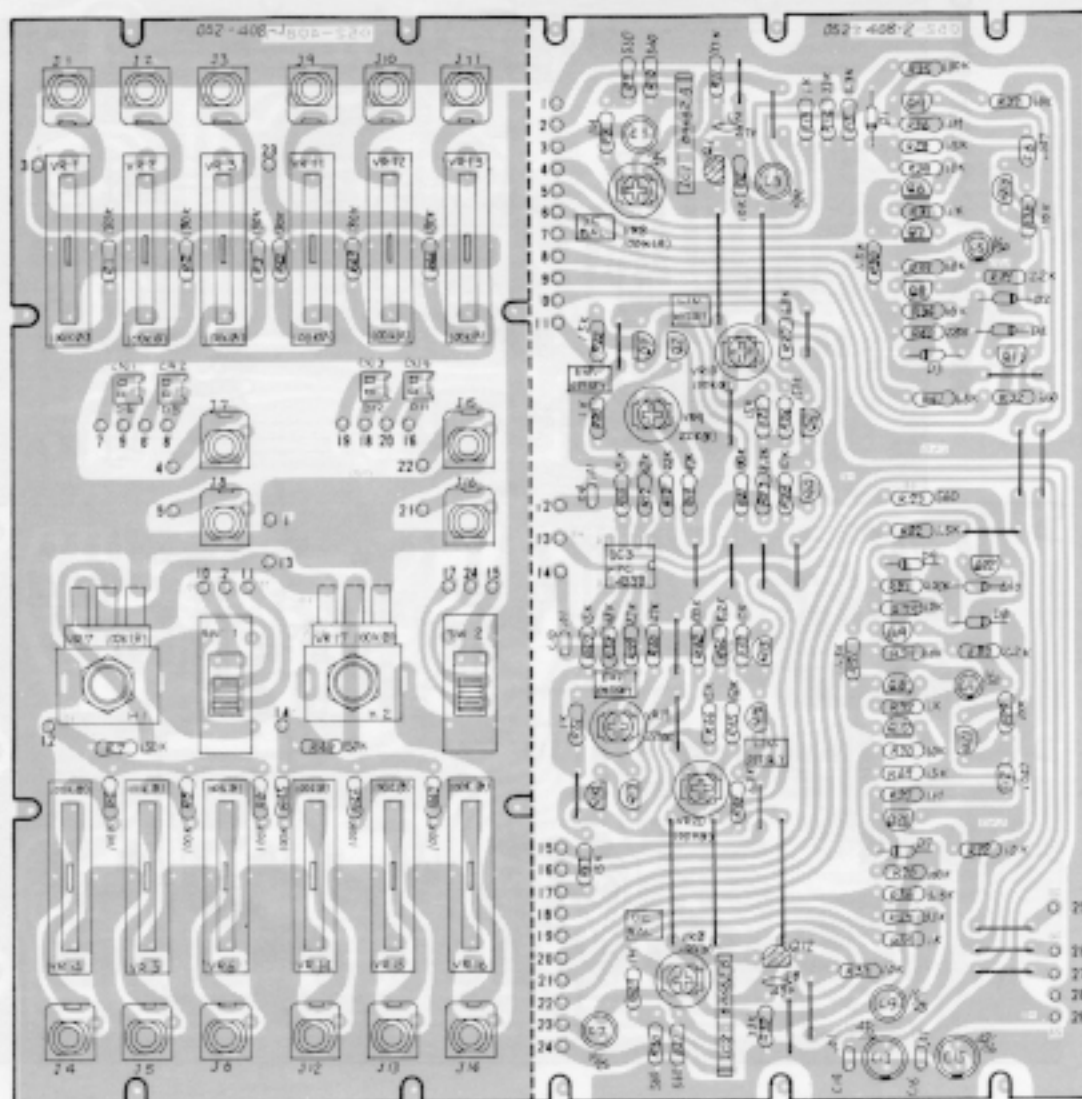

555 TIMER

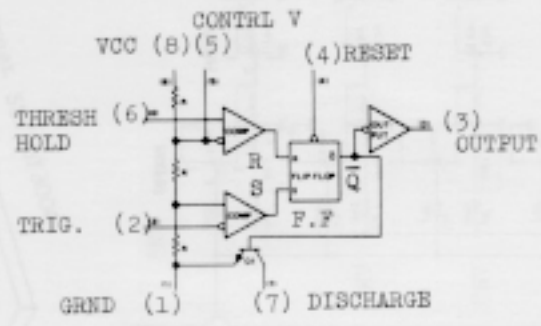

MC14022B OCTAL COUNTER/DIVIDER

TRUTH TABLE

Four stage Johnson octal (Positive Logic) counter with built-in code converter.

CLK	CLK ENABLE	RESET	OUTPUT n
0	X	0	n
X	1	0	n
↑	0	0	n+1
1	X	0	n
1	↑	0	n+1
X	X	0	n
X	X	1	Q0

X Don't Care
If n < 4 Carry=1
Otherwise = 0

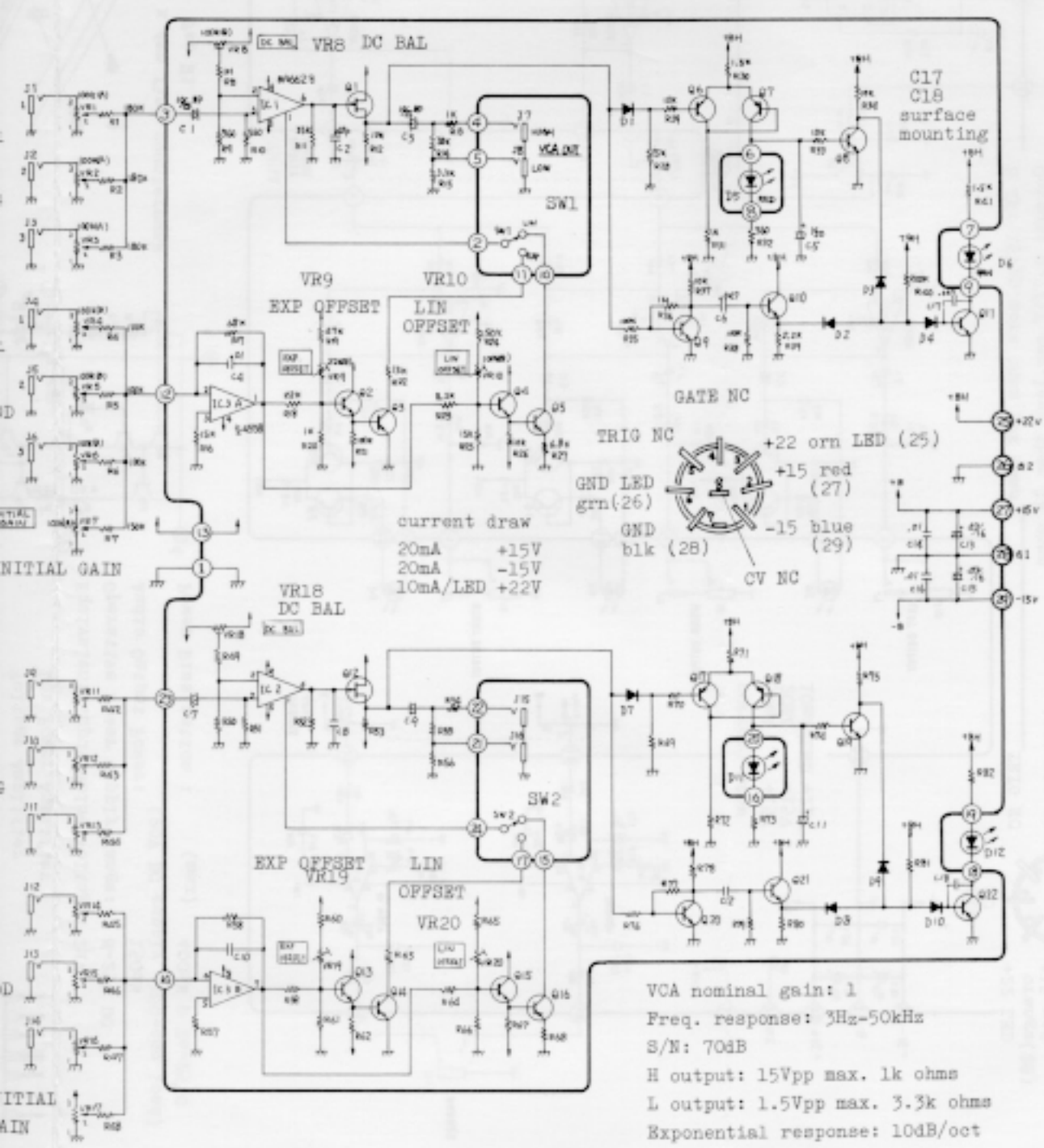
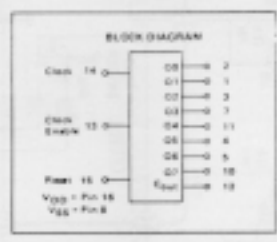

VCA nominal gain: 1
Freq. response: 3Hz-50kHz
S/N: 70dB
H output: 15Vpp max. 1k ohms
L output: 1.5Vpp max. 3.3k ohms
Exponential response: 10dB/oct

NOMENCLATURE	PART NO.	PART NAME
J- 1-5, 7-9	13449402	SJ-409-1-2
J- 6, 8, 10	13449115	HIJ-0264-01-030
J- 11	13449114	HIJ-0264-01-020
SW- 1	13159503	SQPR24-12P
VR- 1-4	13339402	EVA-10A-015B15
VR- 5-8	13219806	GNTOR910E K20 100K-A/C
VR- 9, 11	13219807	GNTOR910E K20 100KB X 2
VR- 10	13219220	VMLORBI10C K20 100KB
H- 8	2219019000	Holder N-190
D- 4-6	15029110	GI-3AR-1
IC- 1, 2	15189105	uPC4558C
IC- 3	15189109	WA301HC
IC- 4	15159105T0	TC4013BP
IC- 5, 6	15199502	TA7066AP
Q- 1-6	15119112	Z8A1015-Y
Q- 7-9	15129115	Z801B15-Y
D- 1-3	15019103	182473
L- 1	2244021200	Coil MC4RV 400uH
C- bl-polar	13639932T0	ECBA25N10 10uF/25V

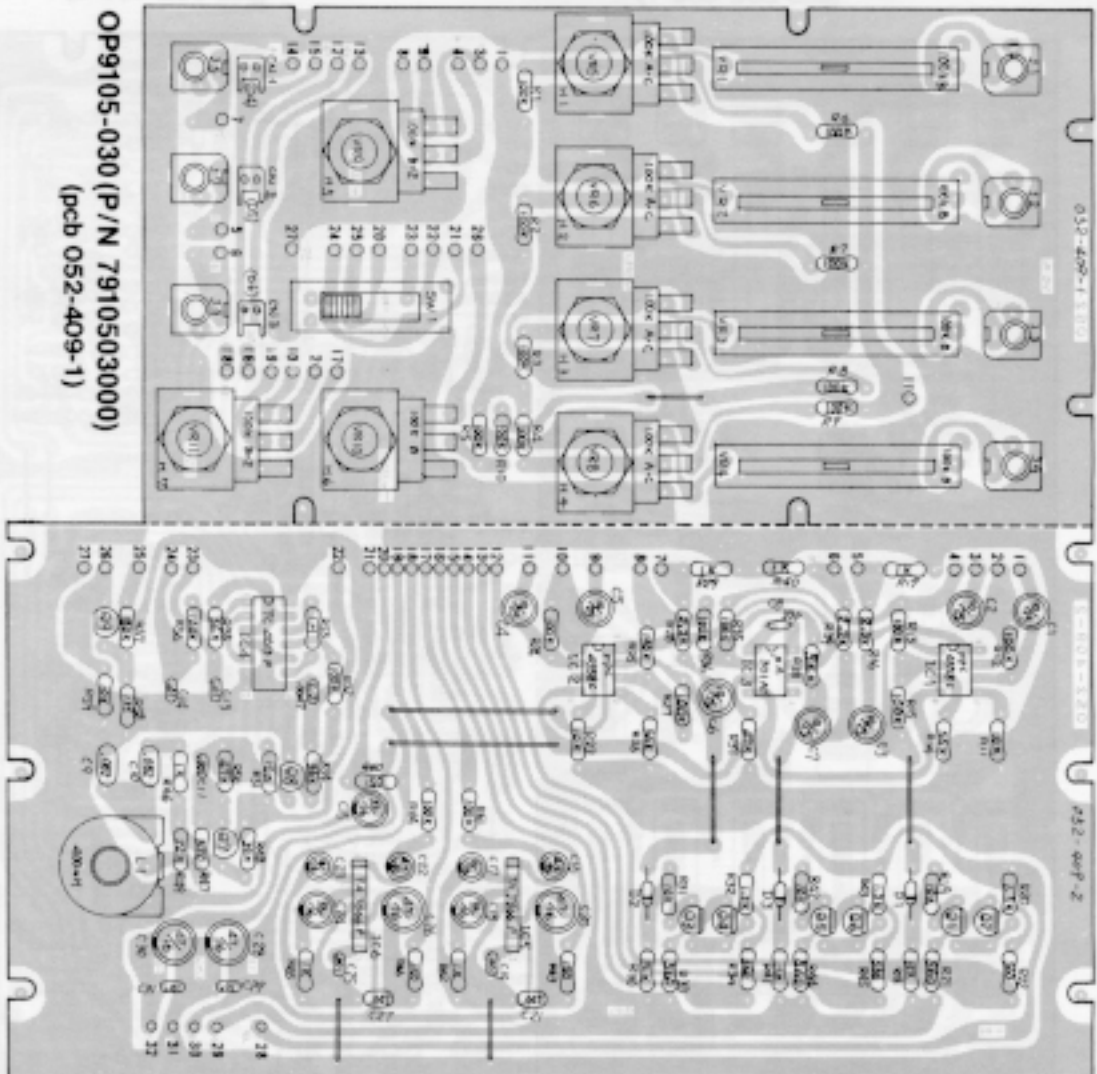
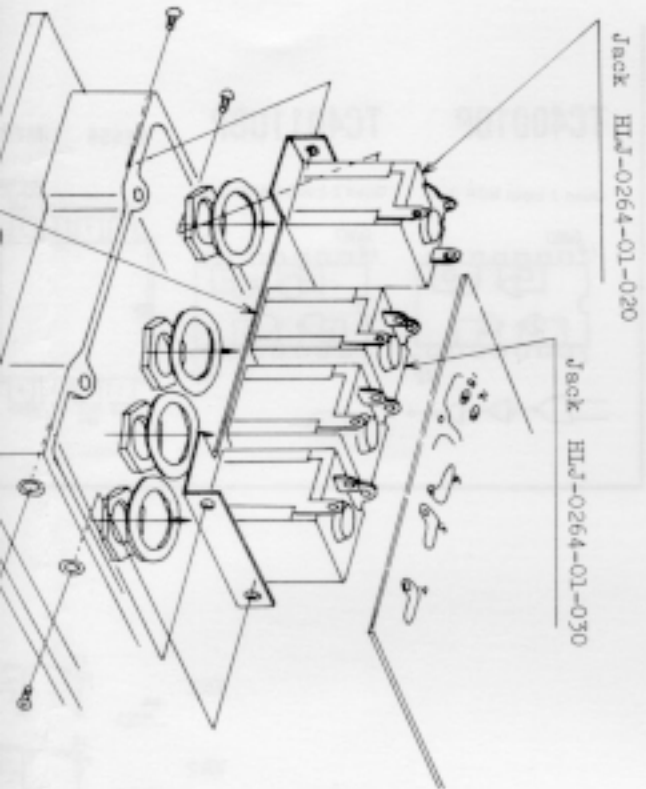

OP9105-030 (P/N 7910503000)
(pcb 052-409-1)

OP9105-040 (P/N 7910504000)
(pcb 052-409-2)

M-131

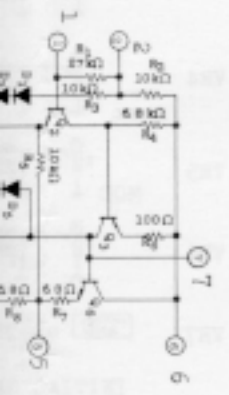

TA7066P

Voltage Amplifier
Low Power Amplifier

Equivalent Input Noise Voltage: 2uV



M-131 OUTPUT MIXER

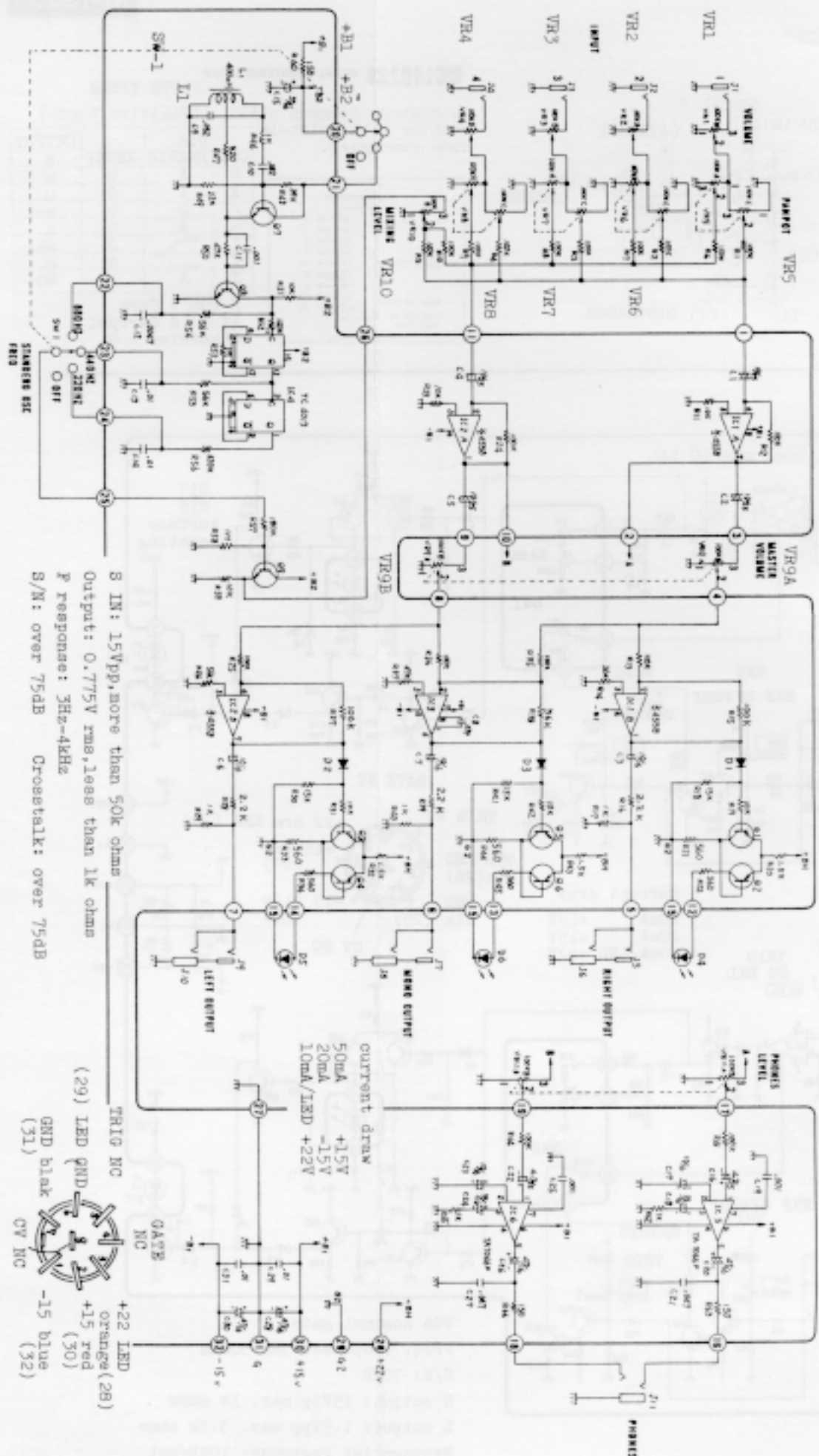

8 IN: 15Vpp, more than 50k ohms
 Output: 0.775V rms, less than 1k ohms
 f response: 3Hz-4kHz
 S/N: over 75dB
 Crosstalk: over 75dB



current draw
 50mA +15V
 20mA -15V
 10mA/LED +22V

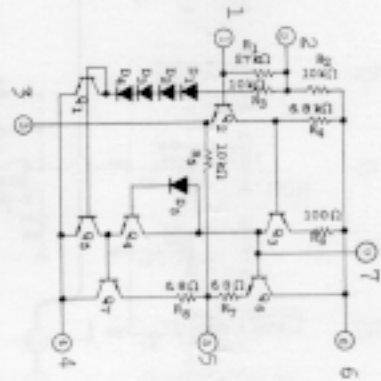
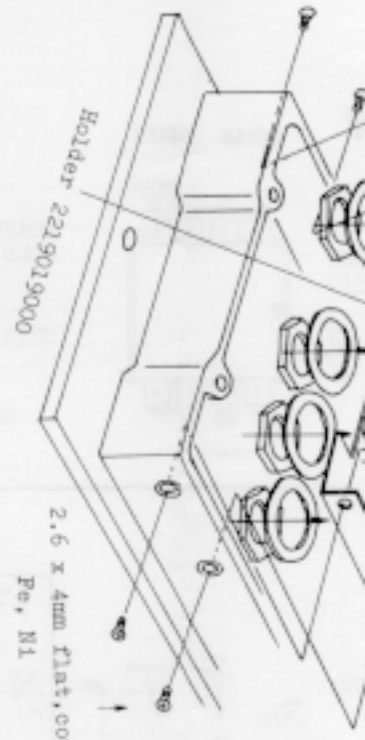

TA7066P
 Voltage Amplifier
 Low Power Amplifier
 Equivalent Input Noise Voltage: 2nV
 Operative Power Supply Range: 9-25V DC
 Audio Output Power: 150mW
 Power Dissipation: (20V DC supply 150-ohm load) 400mW @ T_a=25°C

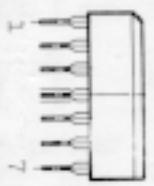

NOMENCLATURE	PART NO.	PART NAME
J-	1-18	13449402 SJ-409-1-2
VR-	1-8	13339304 EVA-H04C15B15
VR-	9, 10	13339402 EVA-TOAC15B15
VR-	11,12	13299544 CR19R 22KB
IC-	1-4	15189105 uPC4558C
Q-	1-4	15119112 2SA1015-Y
D-	1-4	15019103 1S2473
C-	○	13639149JO ECE-A16V47 47/16V

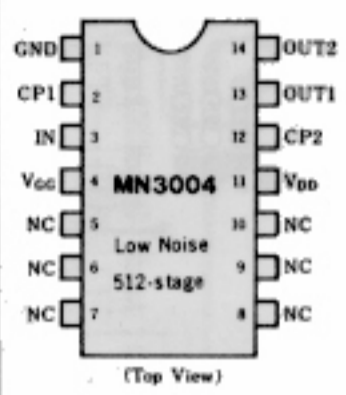

BBD

Signal Delay Time
2.56ms-25.6ms

S/N 85dB typ

VDD -15V

VGG -14V

THD 0.4%

+SIG IN

GAIN ADJ ②

GAIN ADJ ③

-SIG IN

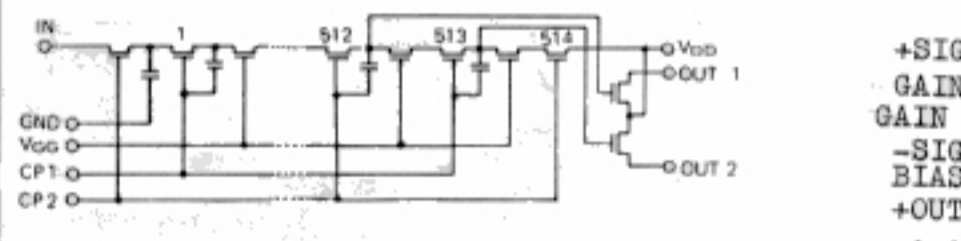

OP9106-030 (P/N 7910603000)
(pcb 052-410-1)

M-132

OP9106-040
(Part Number 7910604000)
(pcb 052-410-2)

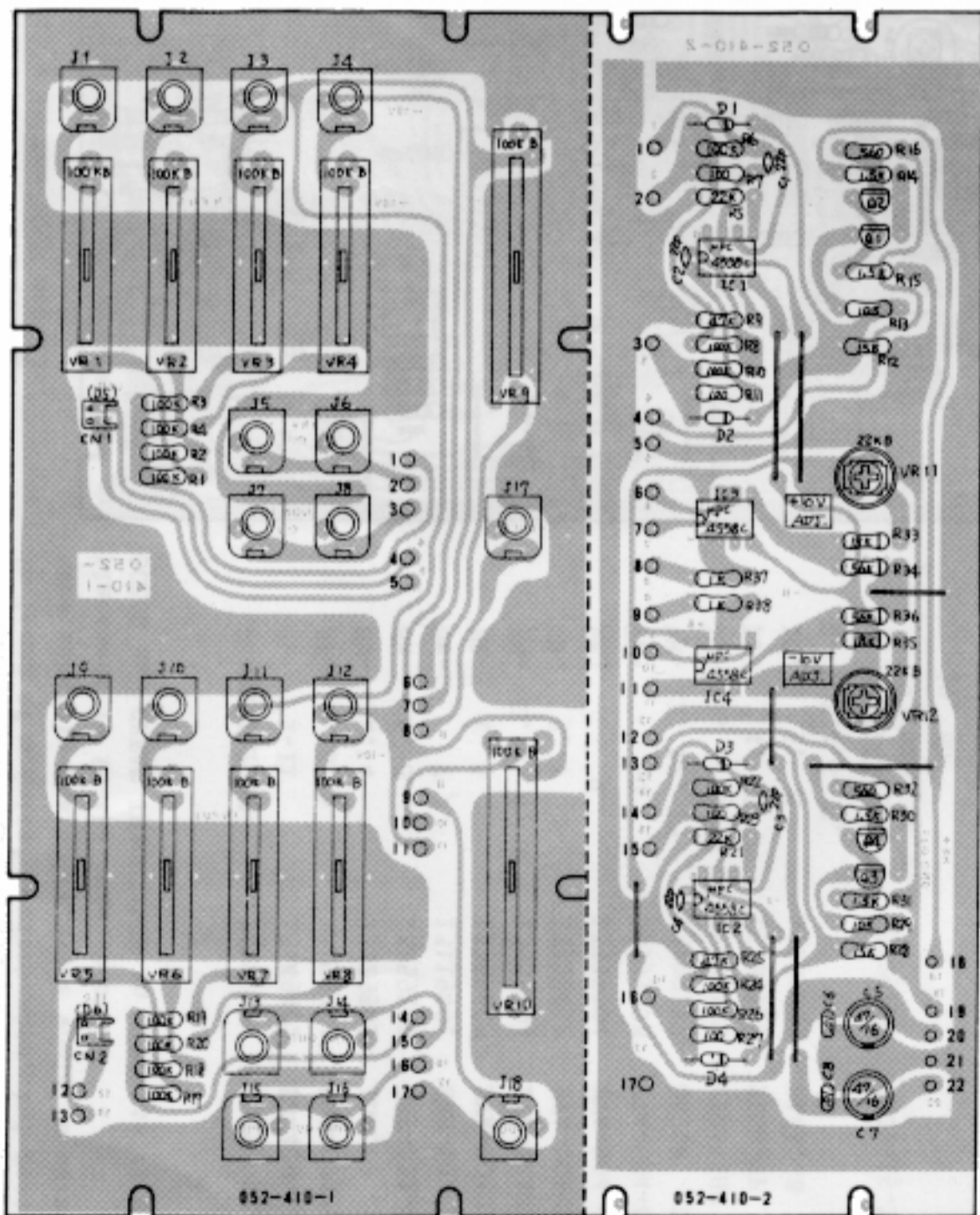

Signal input: $\pm 10V_{pp}$ max. m

Output: $\pm 10V_{pp}$ max. 1k oh

F. response: DC-40kHz

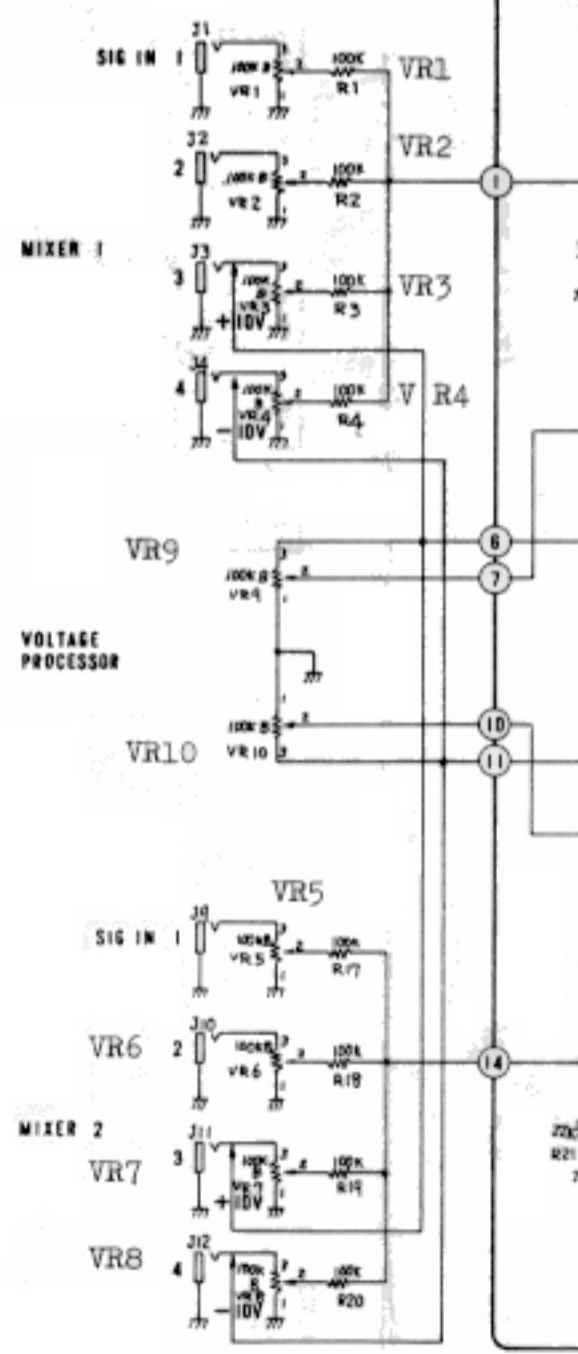

3D

Delay Time
-25.6ms
85dB typ
-15V
-14V
0.4%

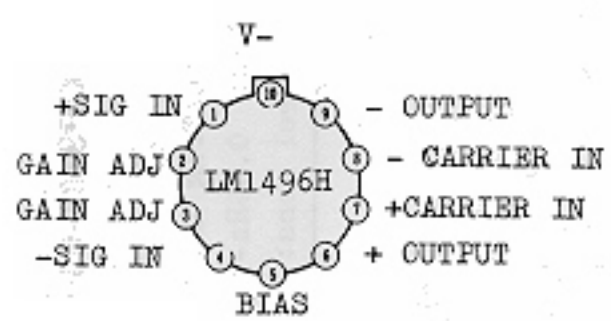

Output voltage is proportional to the product of an input (signal) voltage and a switching (carrier) signal.

Carrier Suppression: 65dB typ. @ 0.5MHz
50dB typ. @ 10MHz

LM1496
balanced modulator-demodulator

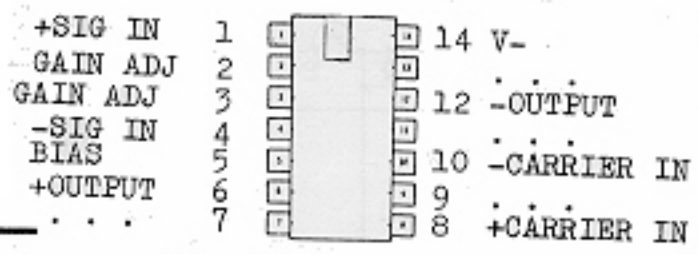
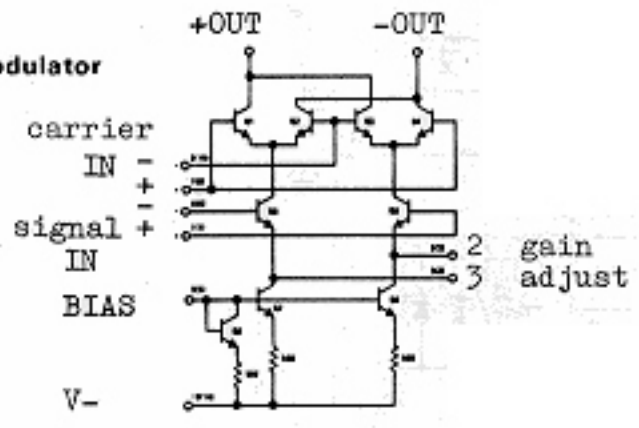

LM1496N

Input: $\pm 10V_{pp}$ max. more than 50k ohms
Output: $\pm 10V_{pp}$ max. 1k ohms
Response: DC-40kHz
S/N: over 90dB

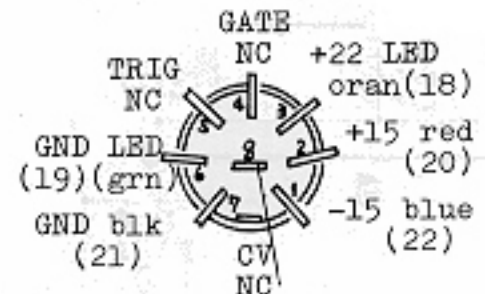
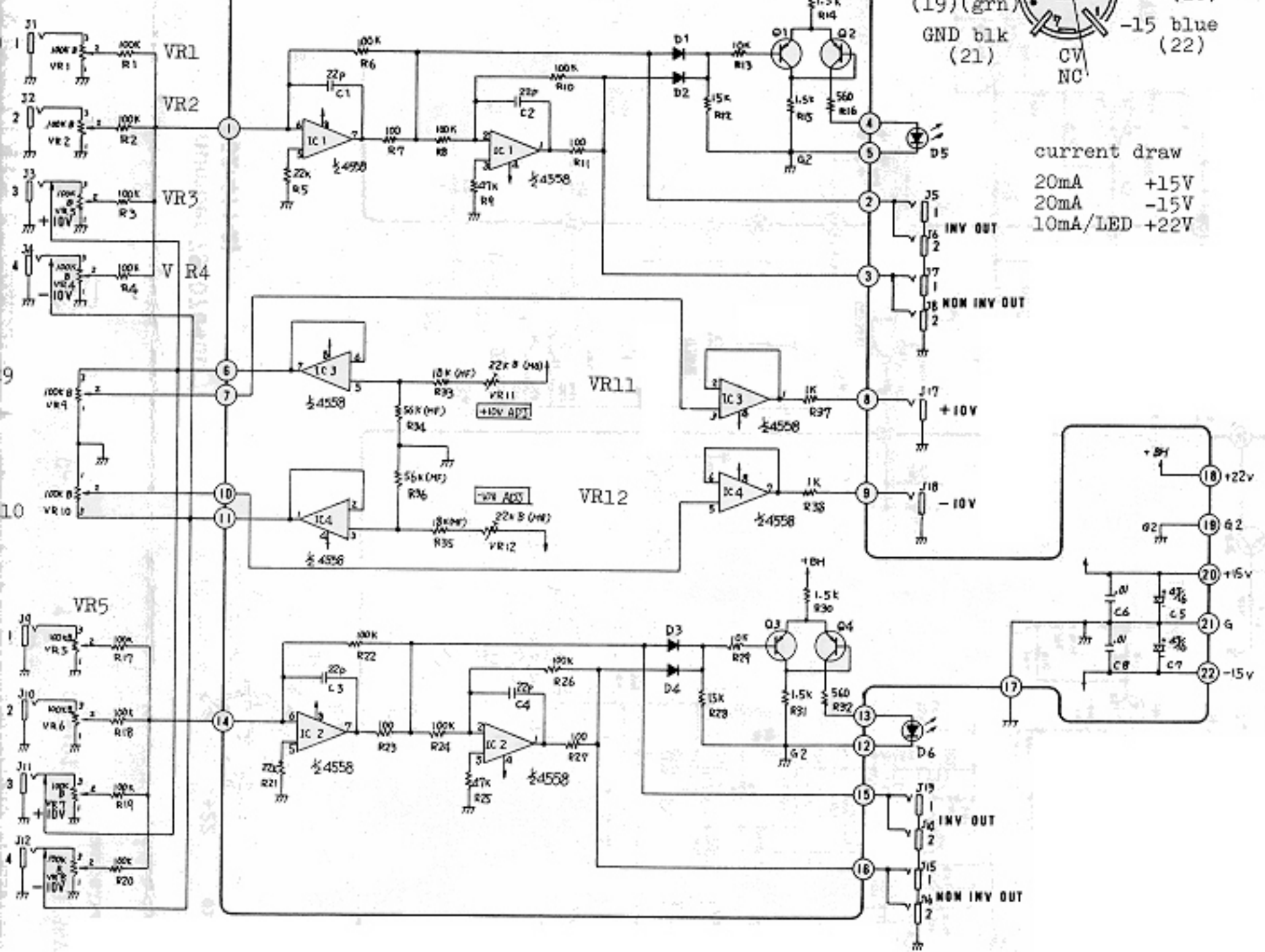

current draw
20mA +15V
20mA -15V
10mA/LED +22V

BA662 A
BA662 B

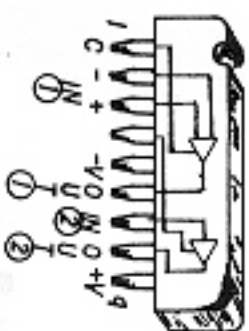

Roland Custom-made DC Controlled Variable Transconductance (g_m) Amp.
 * Device with an "A" suffix features lower offset coefficients.
 * For some particular applications, BA662's are further classified based on "gm" and are painted in a group color. Both BA662 "A" and "B" in the same color are characterized by a "gm" in the range.
 Since suffix "A" indicates superior performance, the BA662 "A's are good alternative for the existing BA662's in the 100M modules.

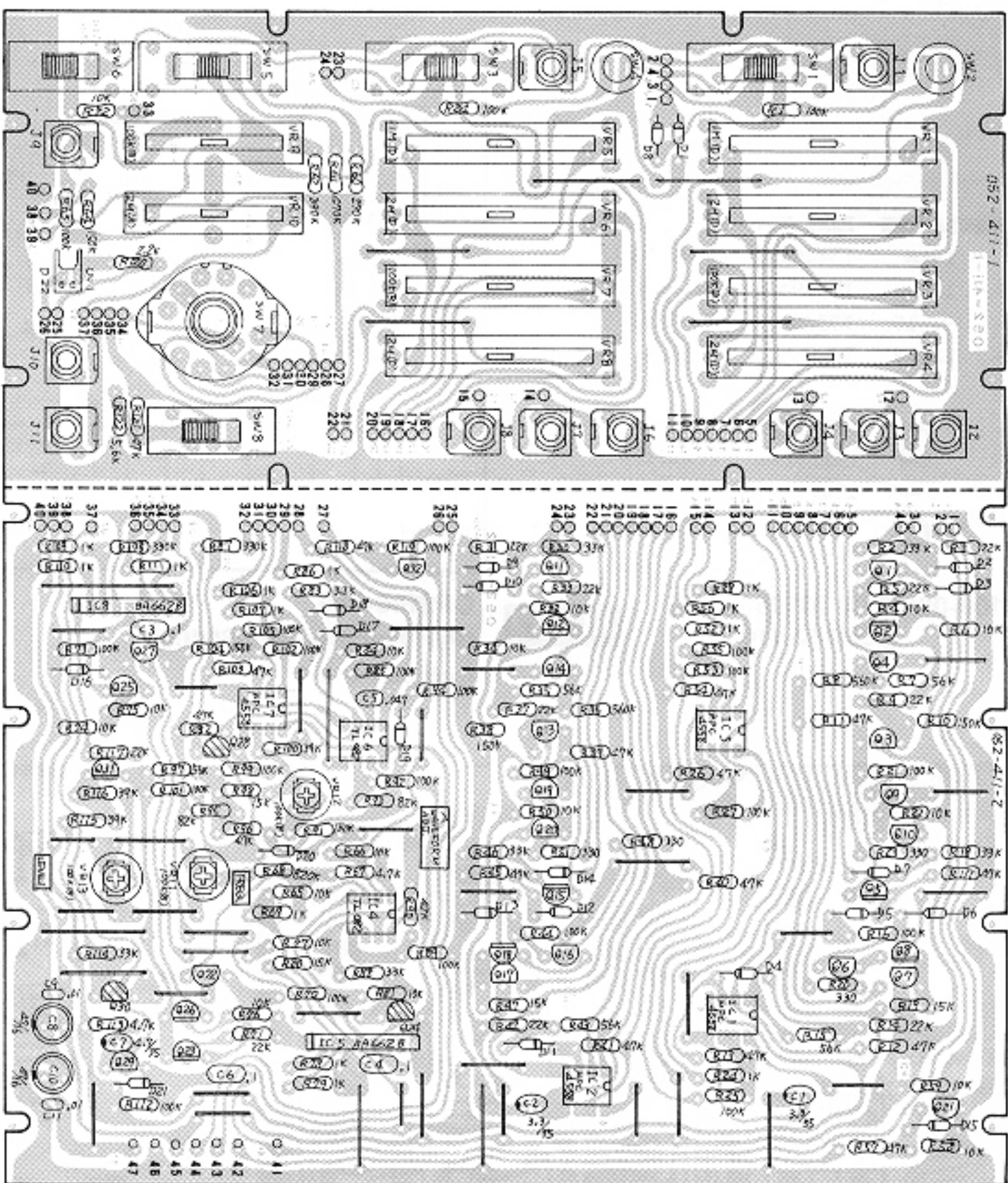

BA662 "B" can replace only where designation is "B" or "A or B" in circuit diagram or on accompanying list. Device without the suffix will be found on several occasions. Labelling them with suffix is preferable for future reference especially when storing as spare. Also, there might be colored ones, inevitable dependency on IC availability, having no significant meaning in terms of modules' performances, but restoration of more accurate characteristics would be expected if replacement is in the same color.
COLOR has GREAT IMPORTANCE in circuits of some MODELS.

NOMENCLATURE	PART NO.	PART NAME
J- 1-11	13449402	BJ-409-1-2
SW- 1, 3, 5	13159304	SSB-02335
SW- 2, 4	13129901	DS-102 red
SW- 6, 8	13159105	SSB-022-42
SW- 7	13119401	SRM-1025172
VR- 1, 5	13339405	EVA-TOAC15D16
VR- 2, 4, 6, 8	13339404	EVA-TOAC15D26
VR- 3, 7	13339402	EVA-TOAC15H15
VR- 9	13339304	BVA-H04-C15B15
VR- 10	13339303	EVA-H04-C15A26
VR- 11, 12, 13	13299117	SR19R 100KB
IC- 1, 2, 3, 7	15189105	uPC4558C
IC- 4, 6	15189118	TL0820P
IC- 5, 8	15229805	BA662-B
Q- 1, 3, 4, 6, 7, 9-11, 13, 14, 16 17, 19-22, 25, 27 29, 32	15129115	28C1815-Y
Q- 2, 5, 8, 12, 15, 18 23, 26, 31	15119112	28A1015-Y
Q- 24, 28, 30	15139103	28K30ATM-GR
D- 1-21	15019103	182473
C- 1, 2	13619710N0	3.3mfd/35V tantalum
C- 7	13619711N0	4.7mfd/35V tantalum

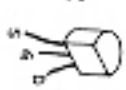

OP9107-030 (P/N 7910703000)
(pcb 052-41-1-1)

M-140 OP9107-040 (Part number 7910704000)
(pcb 052-41-1-2)

Gate/Trig in: 50k ohms, 3V min.
LFO: 0.05Hz-30Hz
Control sens: 1V/oct

Output: 10Vpp, 1k ohms
Delay time: 0-7s

GATE white(41)
TRIG brn(42) +22 LED orn (43)
Gnd LED grn (44) +15 red (45)
Gnd blk (-15 bln(47))
current draw

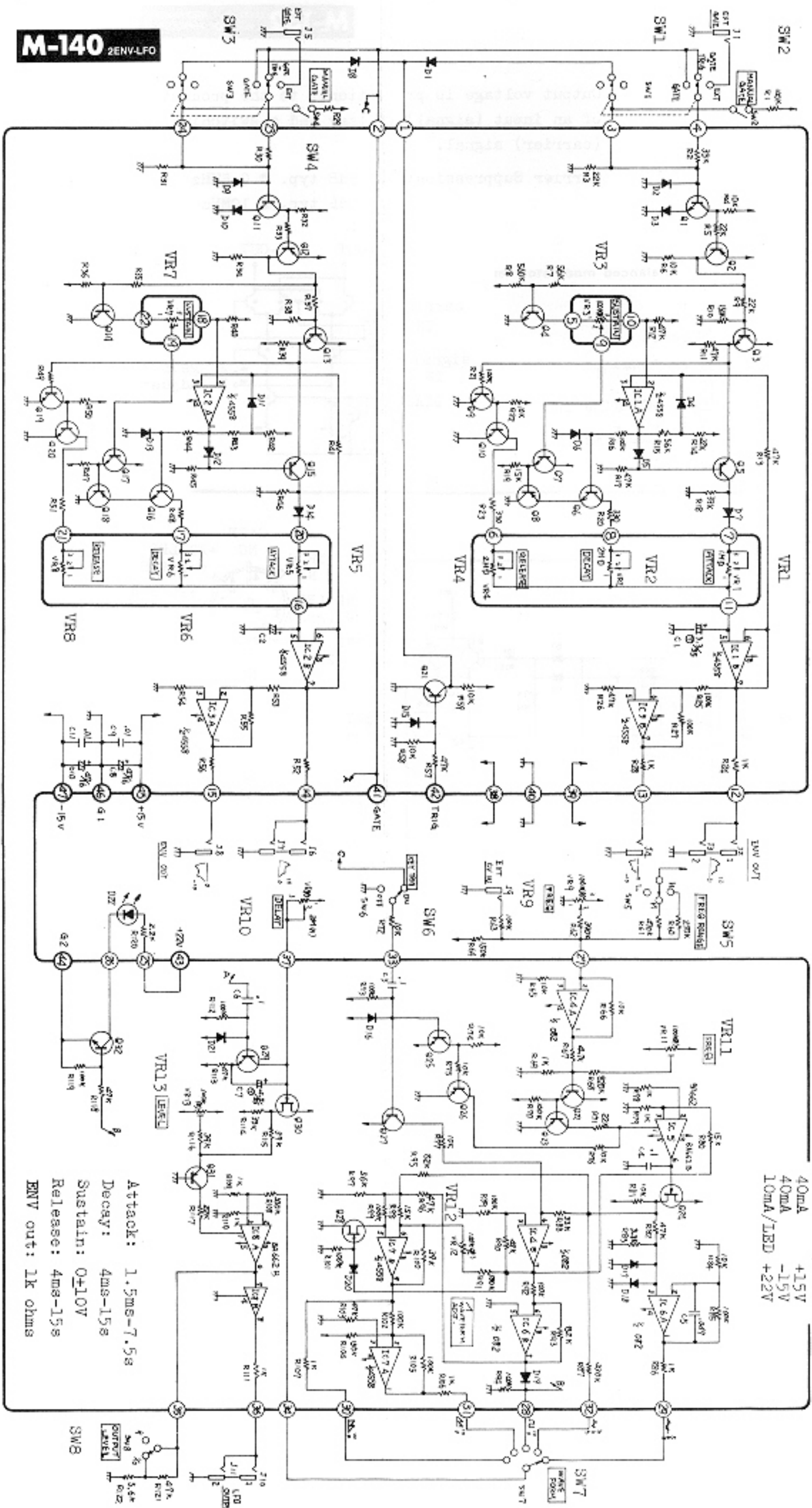

M-140 2ENV-LFO

Attack: 1.5ms-7.5s
Decay: 4ms-15s
Sustain: 0±10V
Release: 4ms-15s
ENV out: 1k ohms

1 A
2 B
3 C
4 D
5 E
6 F
7 G
8 H
9 I
10 J
11 K
12 L
13 M
14 N
15 O
16 P
17 Q
18 R
19 S
20 T

OP9108-030 (P/N 7910803000)
M-150
 OP9108-040 (Part number 7910804000)
 (pcb 052-414-2)

OP9108-030 (P/N 7910803000)
 (pcb 052-414-1)

NOMENCLATURE	PART NO.	PART NAME
J-	1-14	SJ-409-1-2
SW-	1, 2	SSB-02335
SW-	3, 5	SSB-02242
SW-	4	SRML025172
VR-	1, 2	CR19R 100KB
VR-	3	SR19R 10KB
VR-	4	EVA-H04C15A16
VR-	5	EVA-H04C15A55
VR-	6	EVA-H04C15B15
VR-	7	EVA-H04C15A26
VR-	8, 9, 10	SR19R 100KB
CN-	1, 2	3024-02C
IC-	1	IML496N
IC-	2, 3, 8	uPC4558C
IC-	4, 5, 7	TL082CP
IC-	6, 9	BA662-B
Q-	1, 3-5, 7	2SC1815-Y
Q-	9-11, 13, 16, 18, 21	15129115
Q-	2	151291050A 280828R selected for noise generator
Q-	6, 15, 17	15139103 2SK30ATM-GR
Q-	19	15139103
Q-	8, 12, 14	15119112 28A1015-Y
Q-	20	15119112
D-	1-4, 6-11	15019103 1S2473
C-	9	13619709N0 2.2mfd/35V
C-	11	13619707N0 1mfd/35V
C-	16	13619711N0 4.7mfd/35V
C-		tantalum
C-		13639149J0 EC6A16V47 47mfd/16V
C-		13639922J0 EC6A16N10 bi-polar

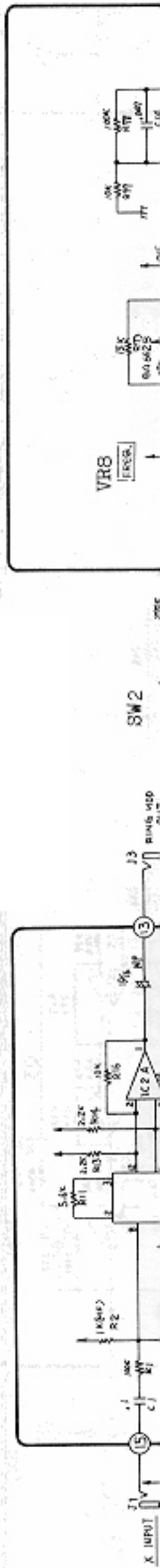
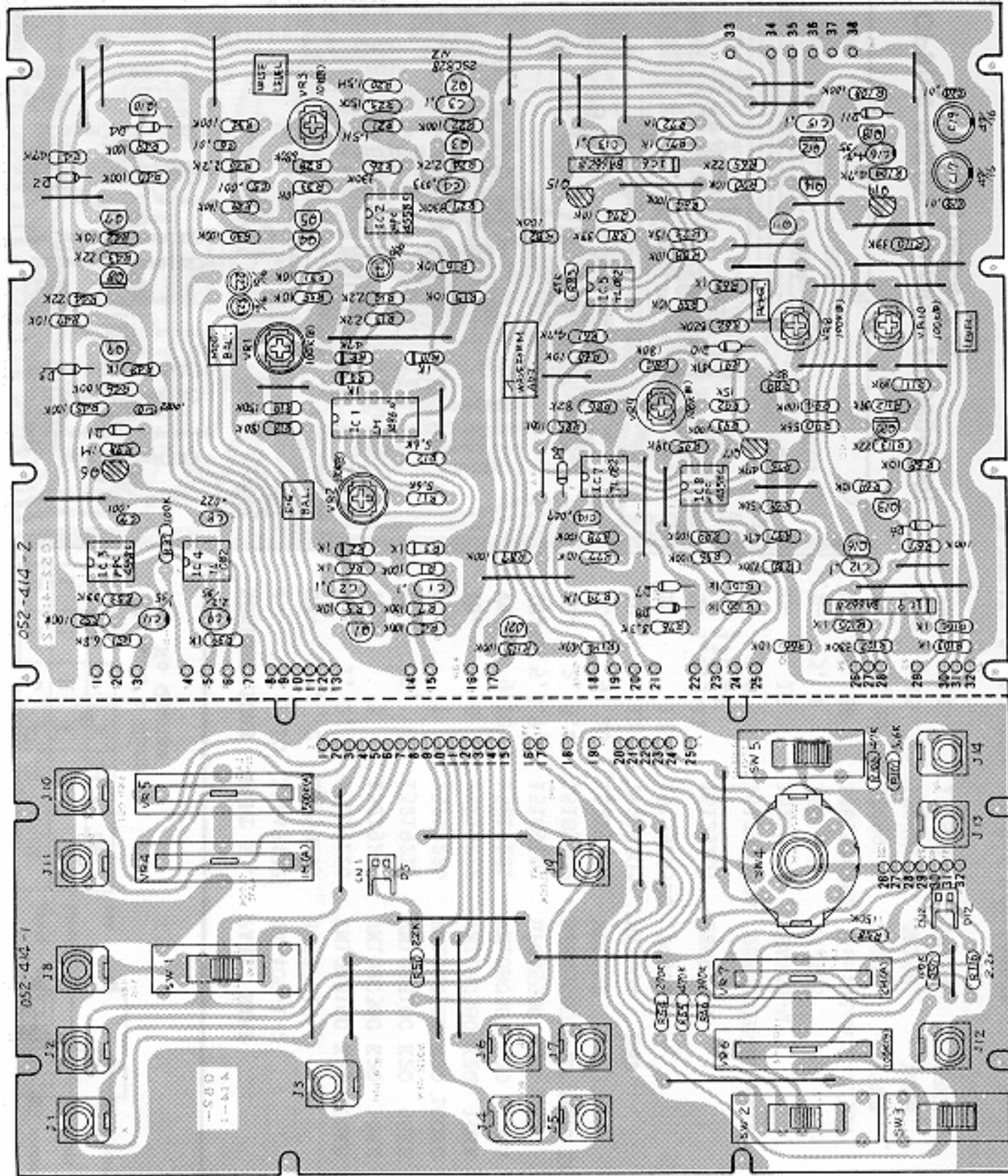

M-150 RING-NOISE S/H LFO

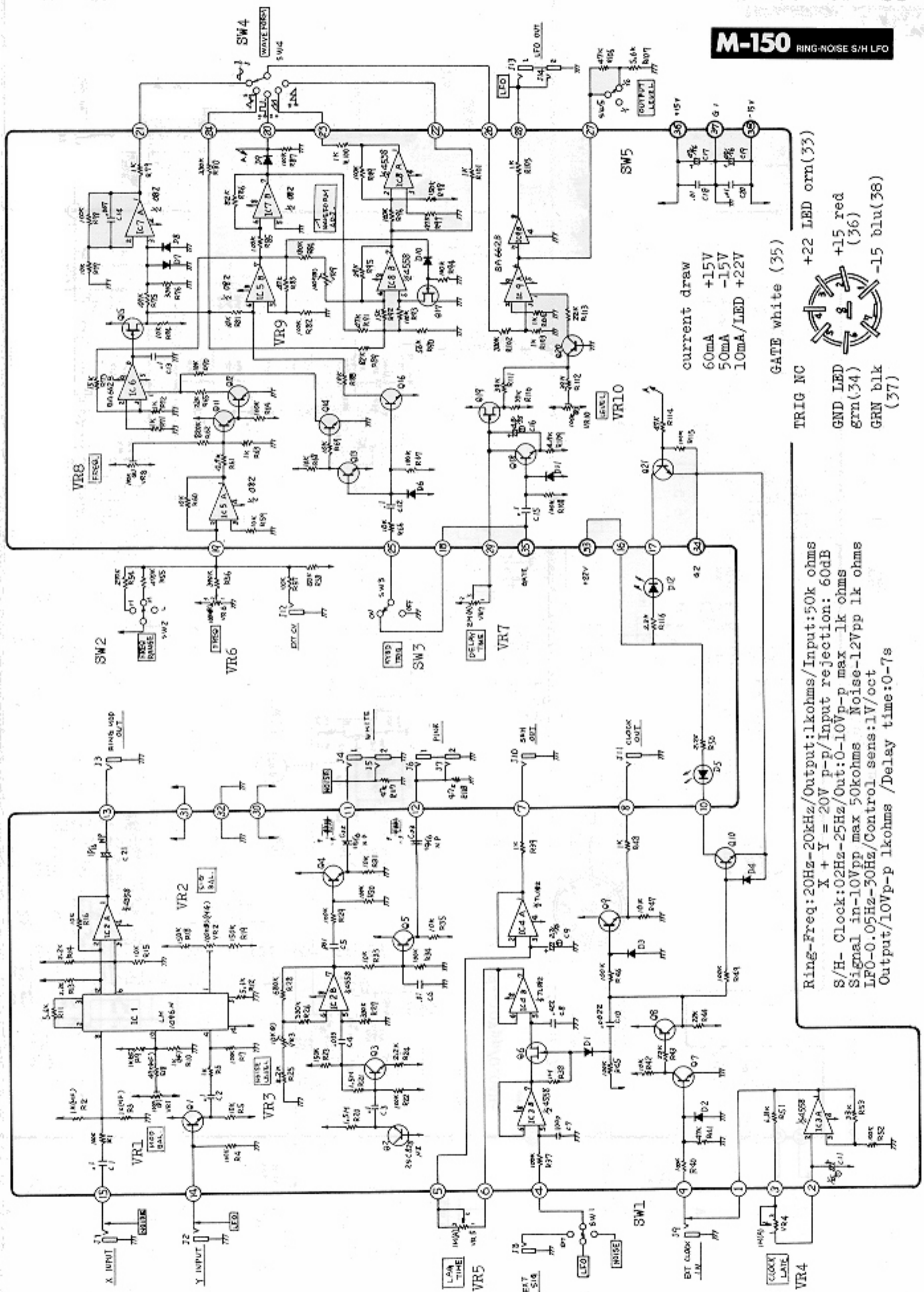

Ring-Freq: 20Hz-20kHz/Output: 1kohms/ Input: 50k ohms
 S/H- Clock: 0.2Hz-25Hz/Out: 0-10V p-p max 1k ohms
 Signal in- 10Vpp max 50kohms Noise- 12Vpp 1k ohms
 LFO- 0.05Hz-30Hz/Control sens: 1V/oct
 Output/10Vp-p 1kohms /Delay time: 0-7s

current draw
 +15V 60mA
 -15V 50mA
 +22V 10mA/LED

GATE white (35)
 TRIG NC
 +22 LED orn(33)
 +15 red (36)
 -15 blu(38)
 GND LED grn(34)
 GRN blk (37)



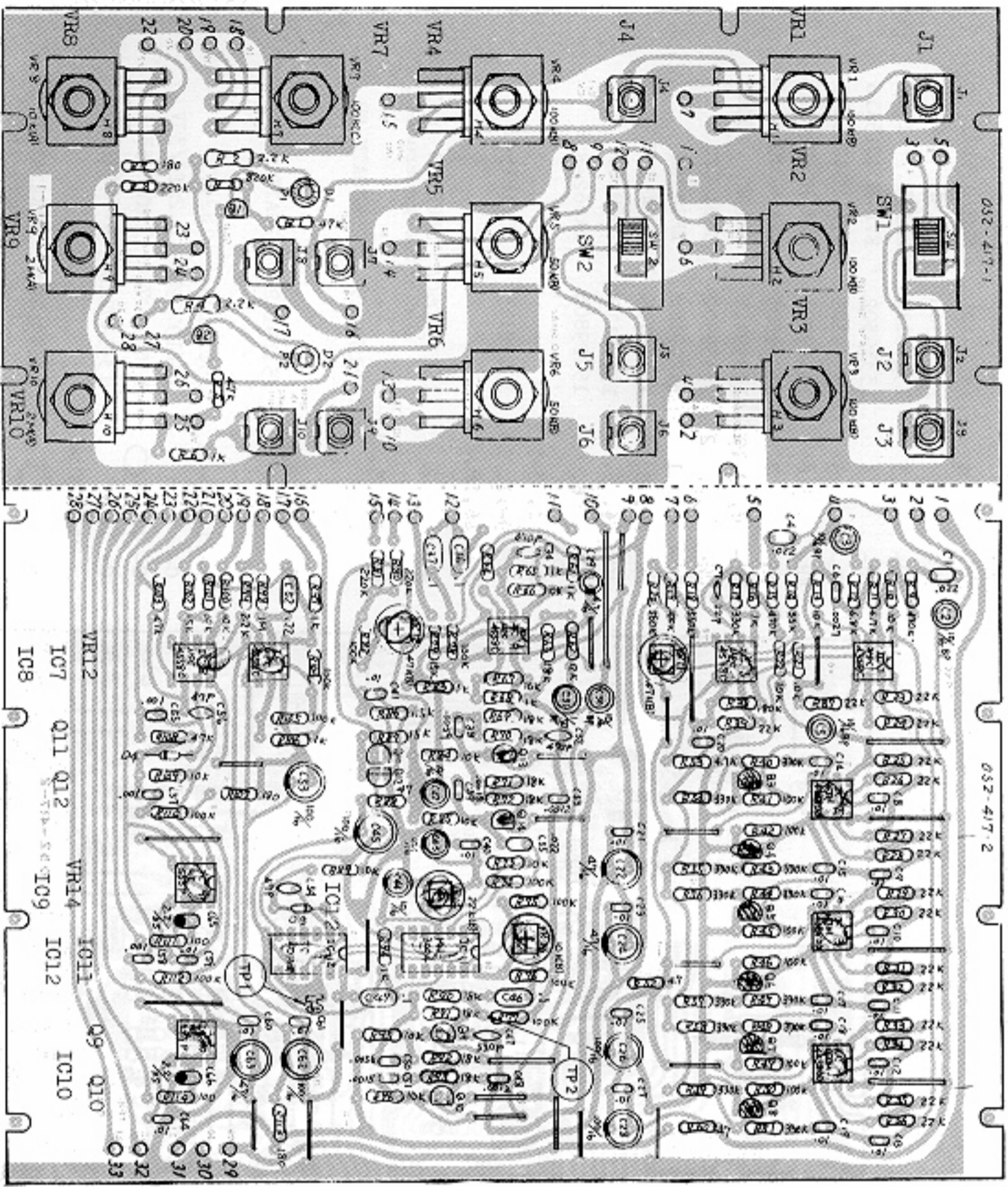

OP9109-030 (7910903000)
(pcb 052-417-1)

M-172
OP9109-040 (Part number 7910904000)
(pcb 052-417-2)

PH. SHIMP-200Hz-8kHz/1080°P resp: 20Hz-20kHz
S/N: 60dB/In: 10V, 50kohm/Out: less 1kohm
EXTCV: 10V max 50kohm/Out: less than 1kohm

A. DELAY-.0m-7ms/30Hz-20kHz/ S/N: 60dB/In: 10V
50k/Out: less 1k/EXTCV: 10Vmax 50kohm

- IC1
- IC5 Q13
- VR11
- IC6
- Q3 Q4
- Q14
- IC2
- Q5
- VR13
- IC3
- Q6 Q7 Q8
- IC4

TRUTH TABLE

INPUTS				OUTPUTS	
Q1	PR	D	CP	Qn+1	Qn+1
L	H	*	*	H	L
L	L	*	*	L	H
H	H	*	*	L	H
L	L	L	L	L	H
L	L	H	L	H	L
L	L	*	*	Qn	Qn

*: Don't Care
.: No Change

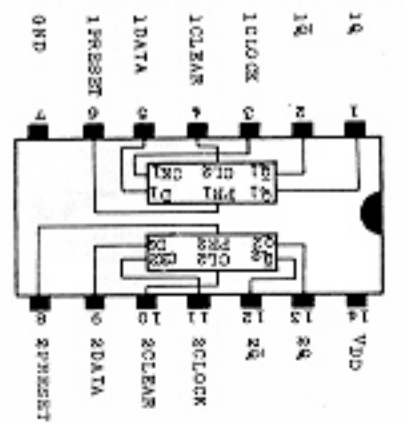

4013B

DUAL TYPE D FLIP-FLOP

NOMENCLATURE	PART NO.	PART NAME
J- 1-10	13449402	BJ-409-1-2
SW- 1, 2	13159103	SSB02242
VR- 1, 2, 4	13219220	VMLORB10C K20 100KB
VR- 3	13219225	VMLORC38C K20 10KB
VR- 5, 6	13219219	VMLORB10C K20 50KB
VR- 7	13219226	VMLORC38C K20 100KC
VR- 8	13219222	VMLORC38C K20 10KA
VR- 9, 10	13219221	VMLORC38C K20 2MA
IC- 1, 5, 6, 7, 8	15189105	uPC4558C
IC- 2, 3, 4	15189102	NJM4558DD BP MONO Dual
IC- 9, 10	15219109	NE555P
IC- 11	15219203	MM3004 BBD
IC- 12	15159105T0	TC4013BP
Q- 1, 2, 9-11	15129107	28C945-Q
Q- 13, 14	1513910304	2SK30ATM-GR selected
Q- 3-8	15119106	2SA733-Q
Q- 12	15019103	182473
D- 3, 4	15019103	182473
C- 65, 66	13619709N0	tantalum 2.2/35V
VR- 11, 12	13299116	SR19R 47KB
VR- 13	13299114	SR19R 10KB
VR- 14	13299115	SR19R 22KB

- IC1
- Q 8
- IC4
- Q 7
- Q 6
- IC 3
- Q 5
- Q 4
- IC 2
- Q 3
- IC 5
- SW1

PH. SHIFT-200Hz-8kHz/1080°/F resp:20Hz-20kHz
 S/N:60dB/In:10V,50kohm/Out:less 1kohm
 EXTGV:10V max 50kohm/Out:less than 1kohm

A. DELAY-.0m-7ms/30Hz-20kHz/ S/N:60dB/In:10V
 50k/Out:less 1k/EXTGV:10Vmax 50kohm

(pcb 052-417-1)

(pcb 052-417-2)

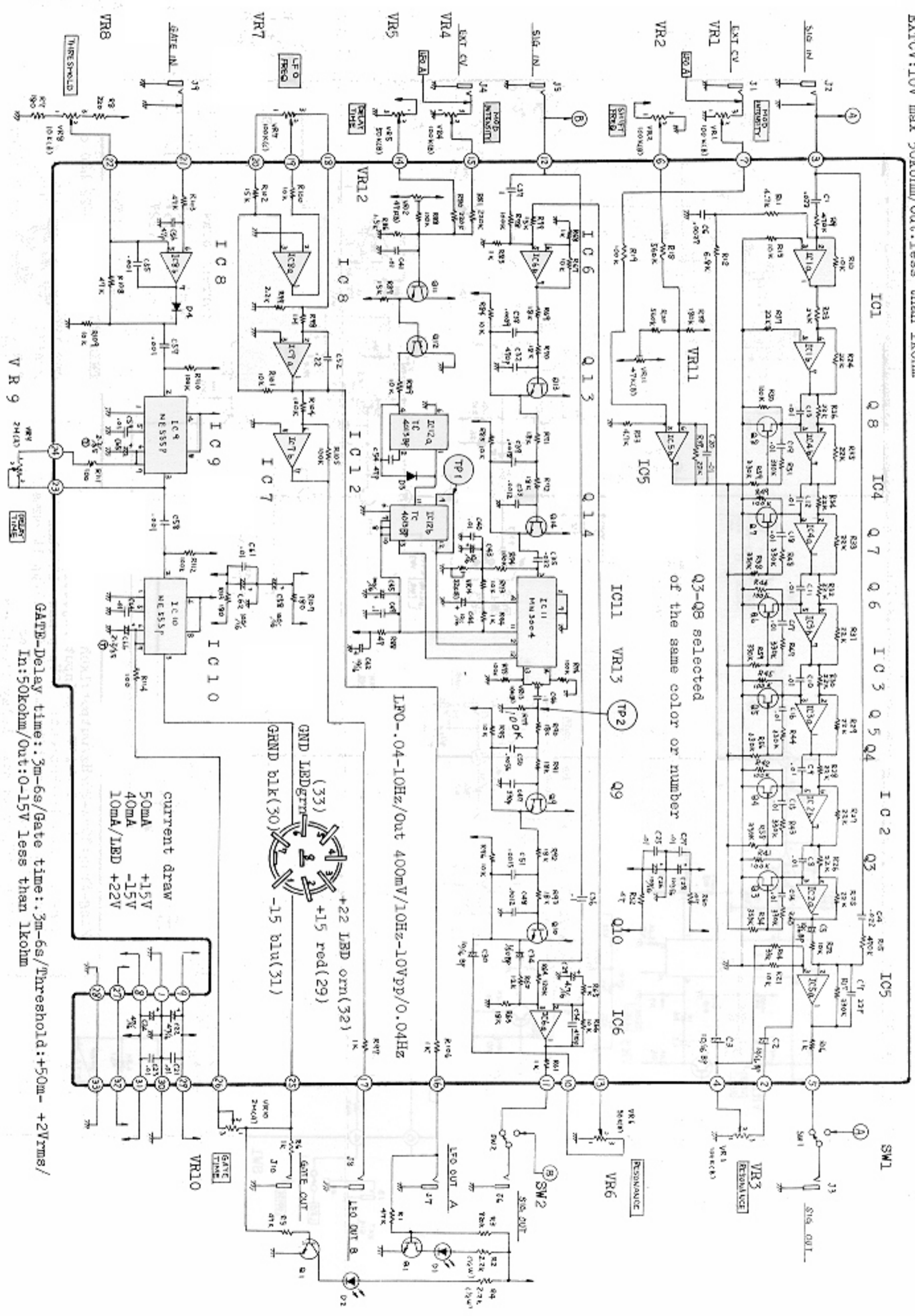

GATE-Delay time: 3m-6s/Gate time: 3m-6s/Threshold: +50m- +2Vrms/
 In: 50kohm/Out: 0-15V less than 1kohm

current draw
 50mA +15V
 40mA -15V
 10mA/LBD +22V



M-172 PHASE SHIFTER/AUDIO DELAY/GATE DELAY

1 2 3 4 5 6 7 8 9 10 11 12 13 14 15 16 17 18 19 20 21

A B C D E F G H I J K L M N O P Q R S T U

J- 1-6	13449402	SJ-409-1-2	SW- 4	13129901	DS-102 red	IC- 4	15159105TO	TC4013BP	Q- 1-8	15119106	28A733-Q
SW- 1	13119702	SRM1018112	IC- 1	15189121	CA3140T	IC- 5	15159102TO	TC4001UBP	Q- 9	15119108	28A798-G
SW- 2	13159302	S8A04301	IC- 2	15189118	TL082CP	IC- 8	15159107ZO	MCL4022B	Q- 10,12-21, 24,25,27	15129107	28C945-Q
SW- 3,5,6	13159102	S8A04202	IC- 3,6,7	15159104TO	TC4011BP	IC- 9,10	15189105	uPC4558C			

See bottom for remainders.

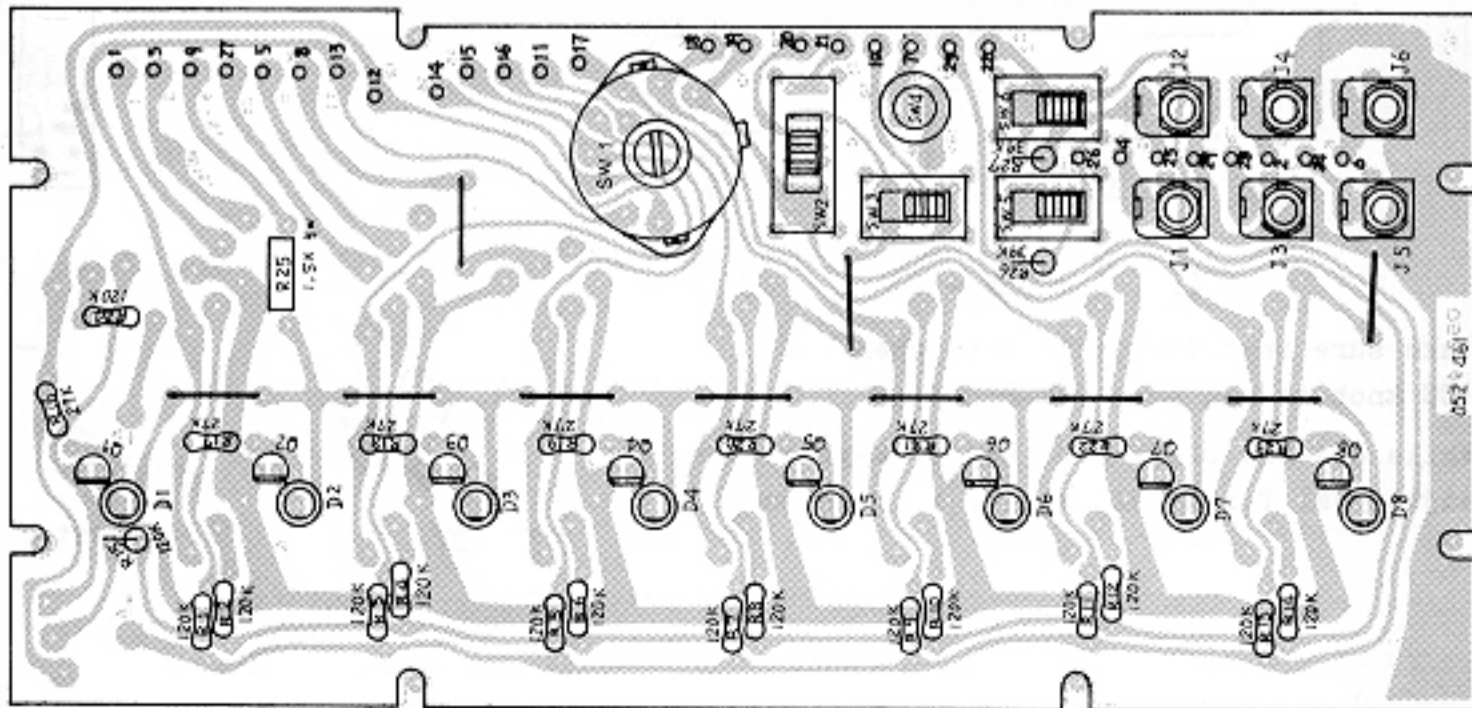

OP110-030 (P/N 7911003000)
(pcb 052-461)

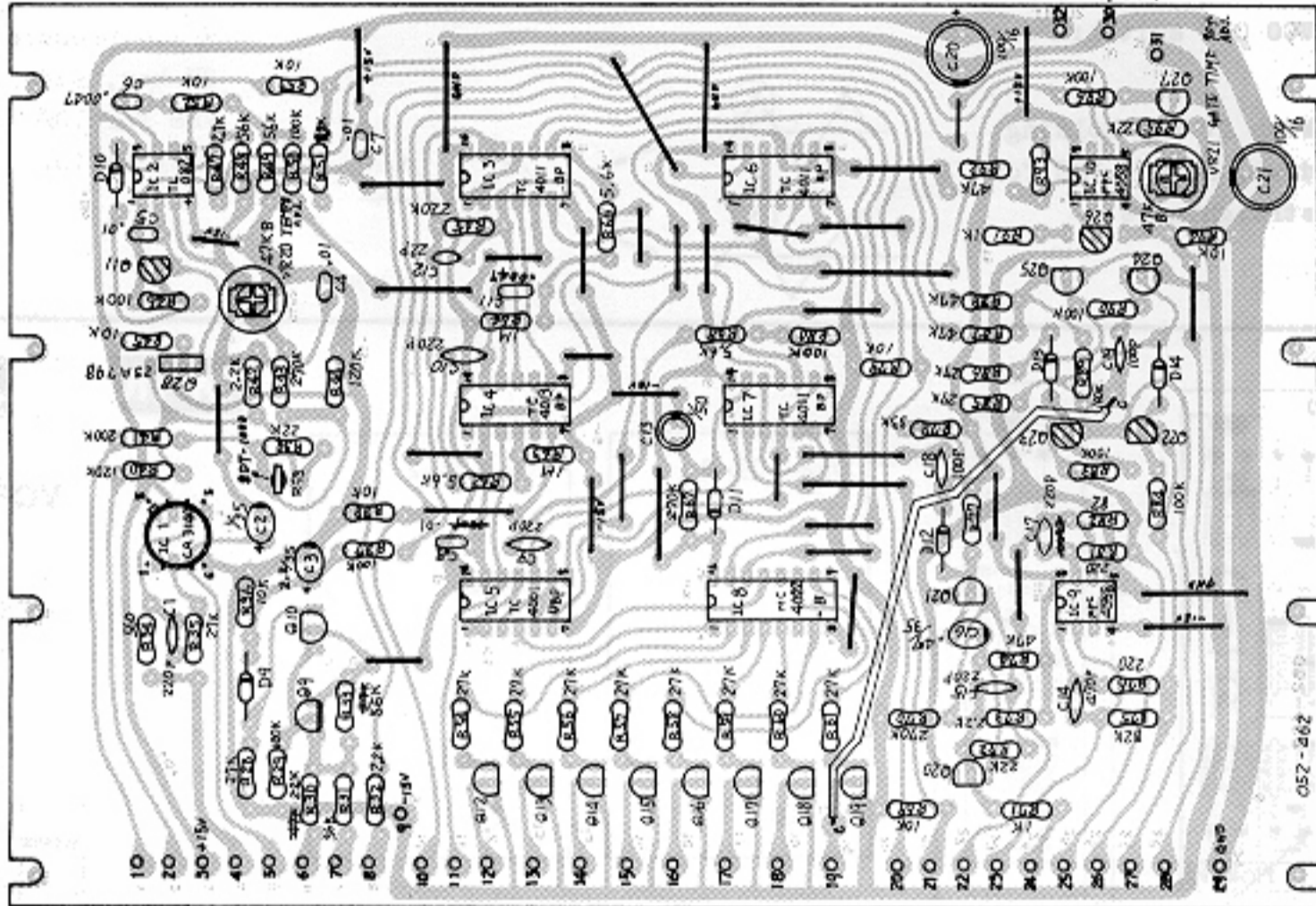

OP11-040 (Part number 7911004000)
(pcb 052-462)

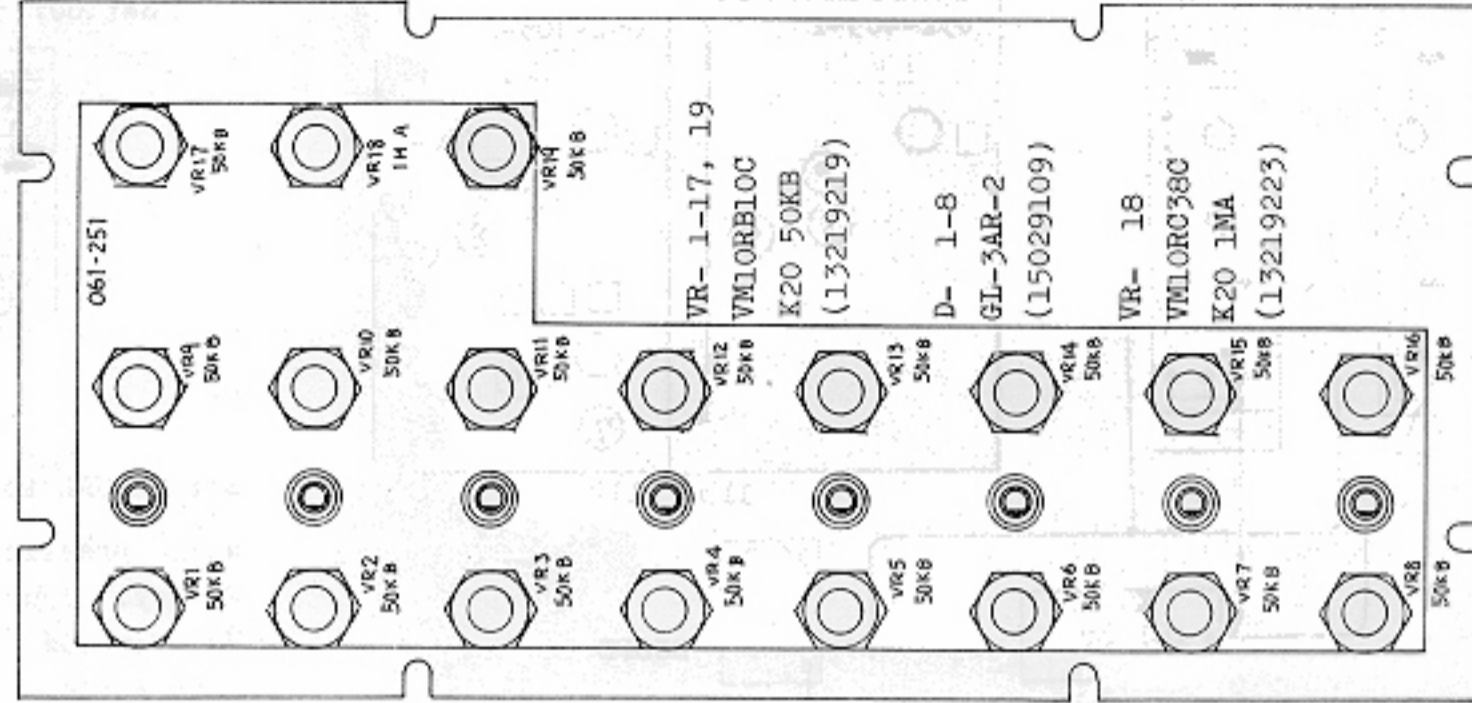

VR- 1-17, 19
VM10RBLOC
K20 50KB
(13219219)
D- 1-8
GL-3AR-2
(15029109)
VR- 18
VM10RC38C
K20 1MA
(13219223)

Tempo: 78-3ms (0.14Hz-33Hz)
Gate time: 10-90%
CV out: 0.3-10V

Gate out: +14V
less than 2k ohms
Tempo in: 0-10V/120K

Q24 foil side
with pattern cut



M-182

PORTAMENTO: 0-10s

OP110-030 (P/N 7911003000) (pcb 052-461)

OP11-040 (Part number 7911004000) (pcb 052-462)

Tempo: 7s-3ms (0.14Hz-33Hz) PORTAMENTO: 0-10s
Gate time: 10-90%
CV out: 0.3-10V

M-182 ANALOG SEQUENCER

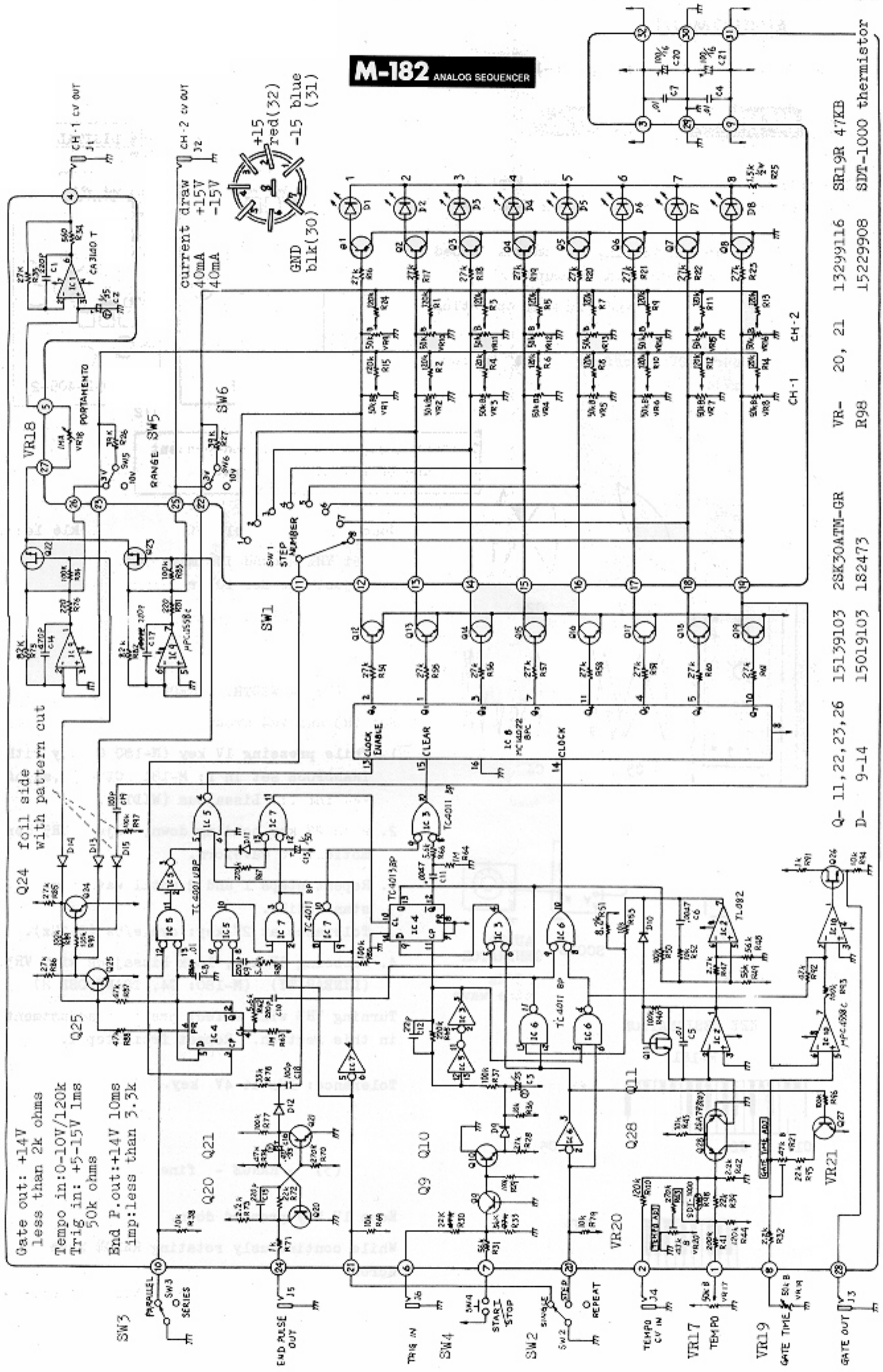

Q- 11, 22, 23, 26 15139103 28K30ATN-GR Q- 20, 21 13299116 SR19R 47KB
 D- 9-14 15019103 182473 R98 15229908 SDT-1000 thermistor

M-110
M-112

VCO continued

(5) - RECTANGULAR -

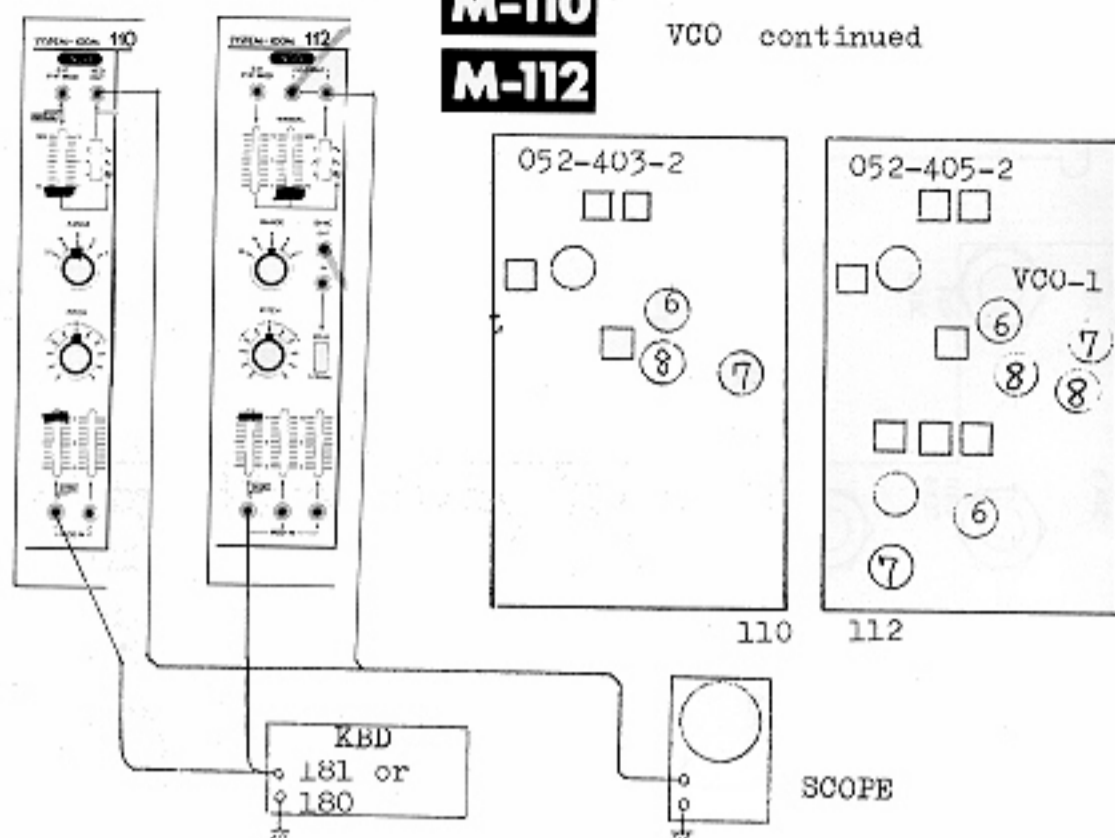

Set OUT switch to

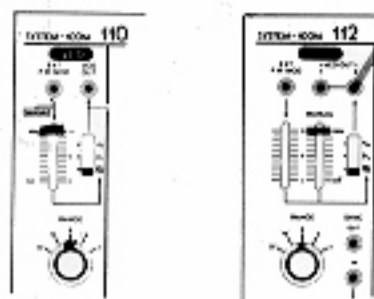

Set MANUAL to 50% (0).

While pressing 2V key, adjust VR7 for 50% duty ratio.

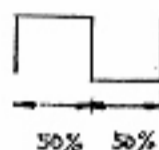

(4) - TRIANGULAR -

VCO OUT switch:

With 2V key holding down, adjust VR6 for straightness.

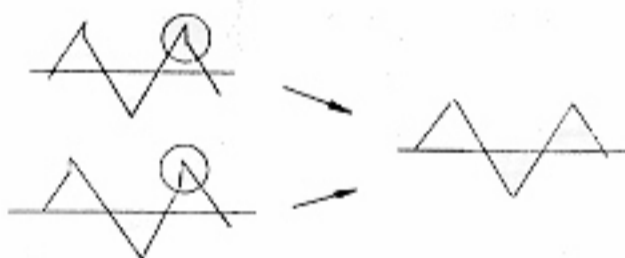

Set MANUAL to MIN (10).

While pressing 2V key, adjust VR8 for 10% duty ratio.

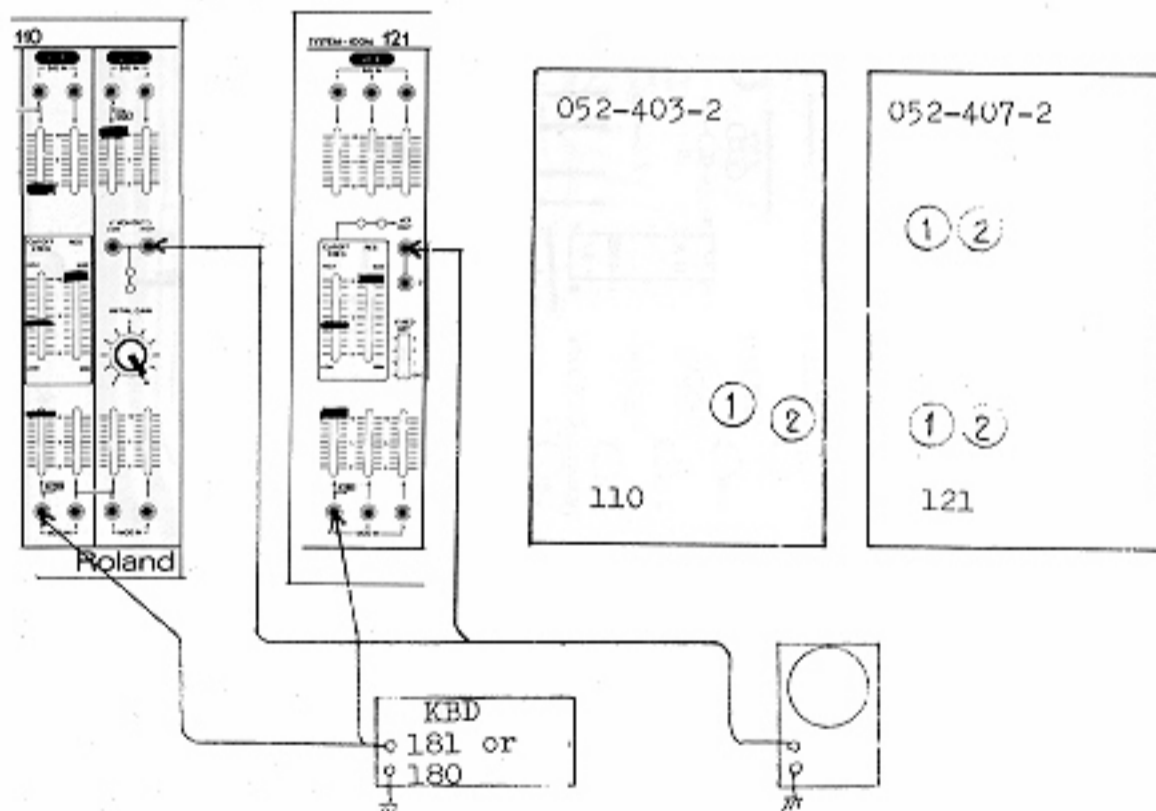
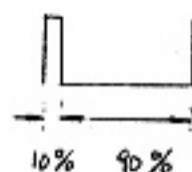

M-110 VCO-VCF-VCA

M-121 2VCF

VCF

(2) - FREQUENCY -

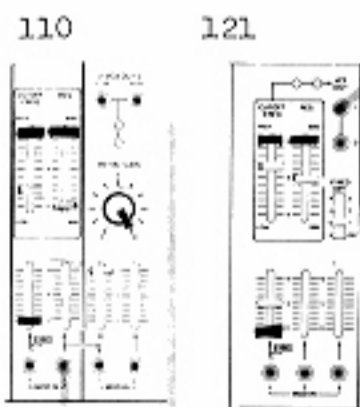

(1) - WIDTH -

Make sure that VCF oscillates when RES knob is set around 7-8th line.

While quickly playing 2V and 3V keys alternately, adjust VR1 for waveforms 1:2 in frequency.

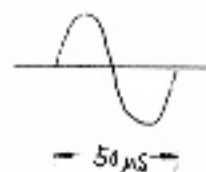
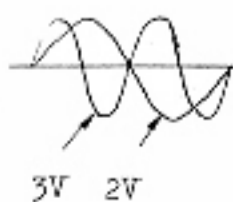

Adjust VR2 for 20kHz (50us).

ADJUSTMENT

For M-180 and M-181, see pp. 16-17.

M-110 VCO-VCF-VCA

M-112 2VCO

The following precautions should be kept in mind before starting adjustment on M-180 and M-181.

Leave the test and testing equipments turned on for 20-30 minutes as a warmup period.

Keep room at a normal and constant operating temperature.

Check keyboard KCV or reference voltage for 1V/oct ($\pm 1mV$).

VCO

(1) - RANGE - coarse

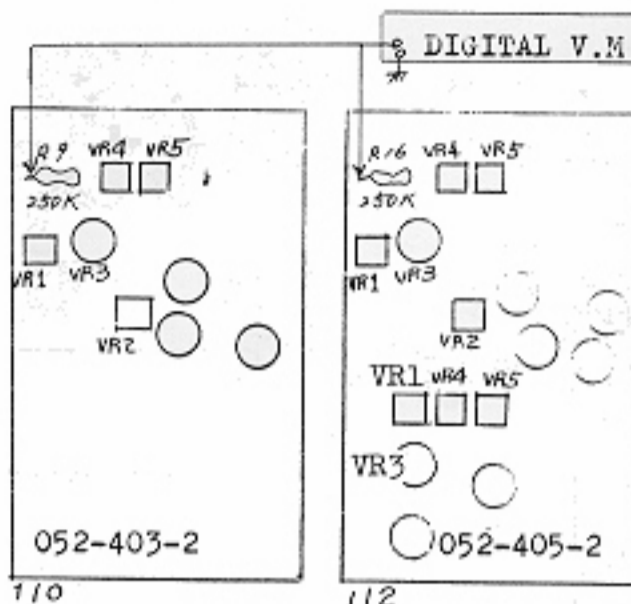

Trimpot designations are independent of those on circuit diagrams.

Connect digital voltmeter to R9 or R16 lead.

1. Set VR1 around its midpoint.
2. Adjust VR2 for 10V reading.

(2) - WIDTH. FREQUENCY -

Set VR3 and VR4 around the midpoint.

1. While pressing 1V key (M-180 C2 key with TRANSPOSE set in L; M-181 C1 key), adjust VR4 for 1:1 Lissajous (WIDTH).
2. With 2V key holding down, adjust VR5 for motionless waveform.
3. Repeat steps 1 and 2 until waveforms stand still.
Tolerance at 2V key: cycle/5s (0.2Hz).
4. Pressing 5V key, lock Lissajous with VR3. (LINEARITY) (M-180: C4, TRANSPOSE H)

Turning VR3 will affect previous adjustments in this section. Repeat from step 1.

Tolerance: 1Hz at 4V key.

(3) - RANGE - fine

Keep 1V key pressed down.

While continuously rotating RANGE knob across full travel range, adjust VR1 for the least detune at every RANGE setting.

110 112

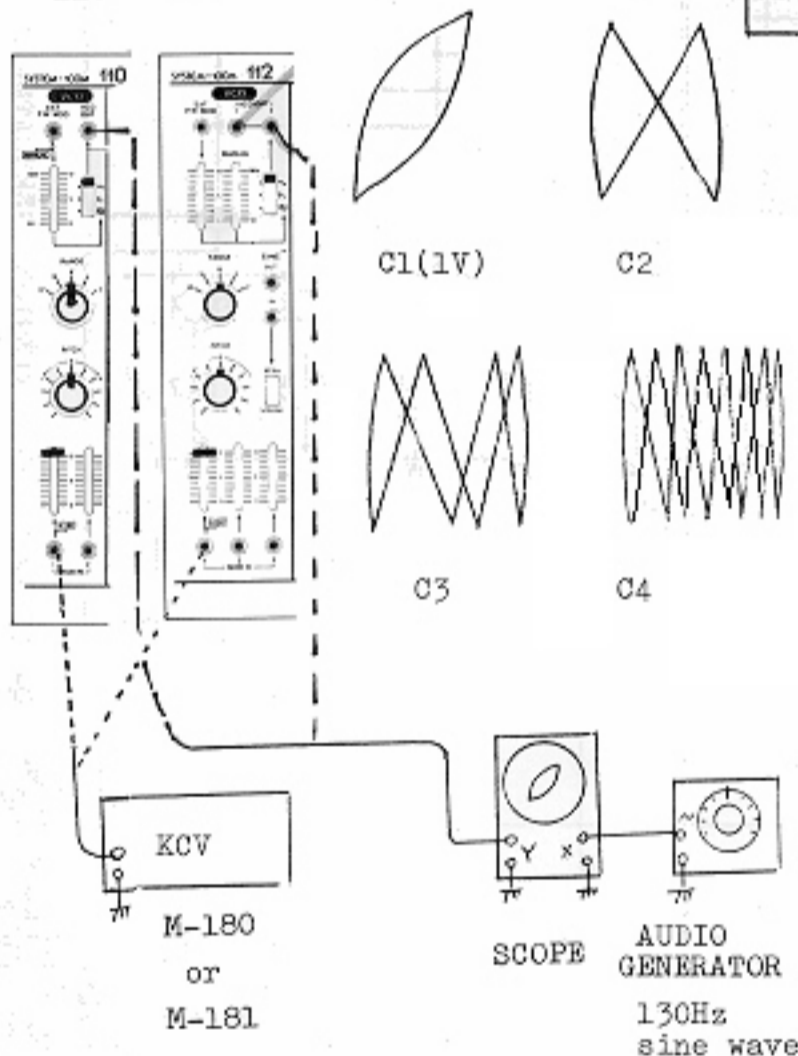

KEY DESIGNATION

M-181



M-180



F1 C2 C3

VCA

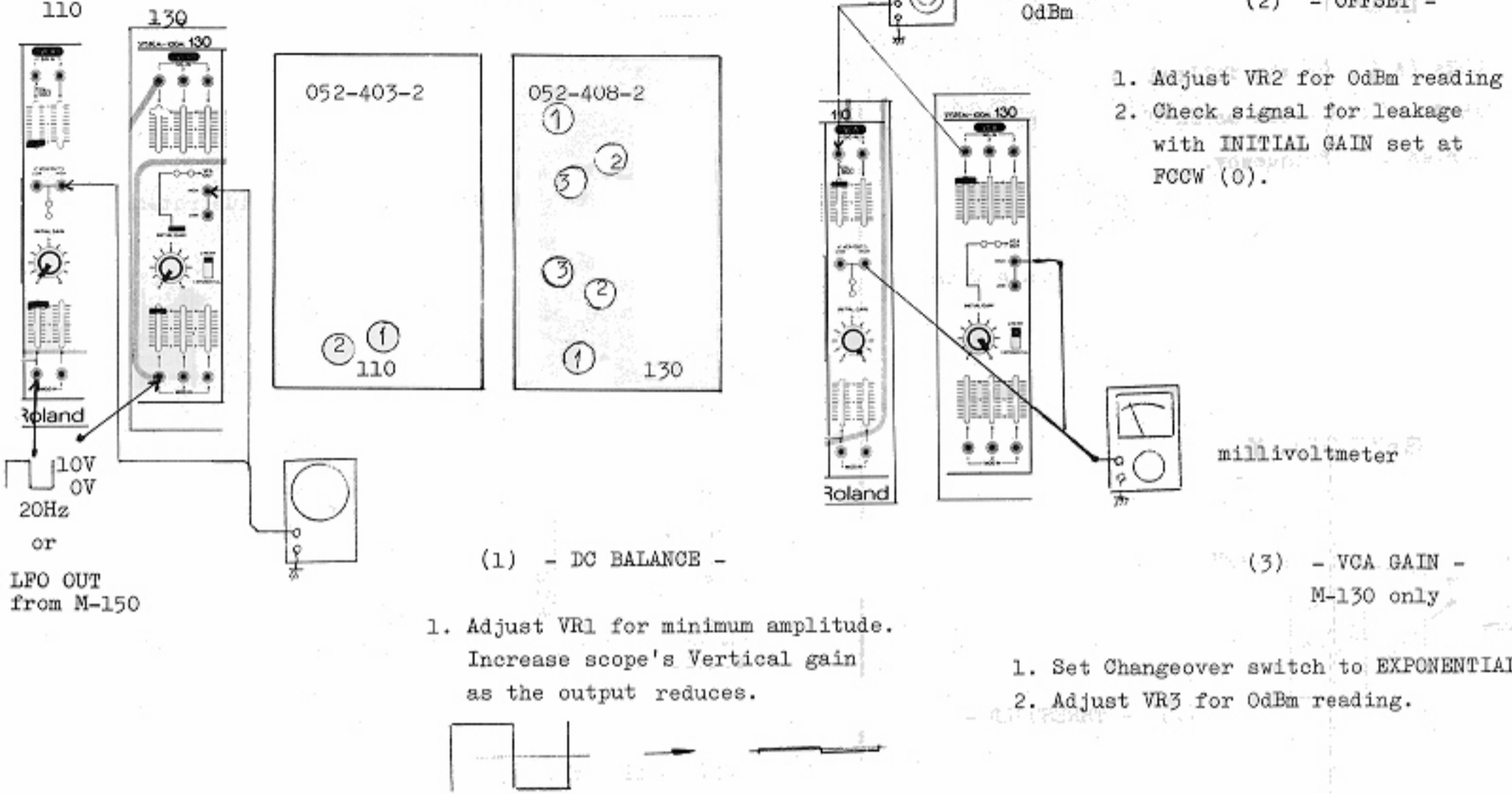

PEAK INDICATOR

M-131 OUTPUT MIXER

STANDARD OSC

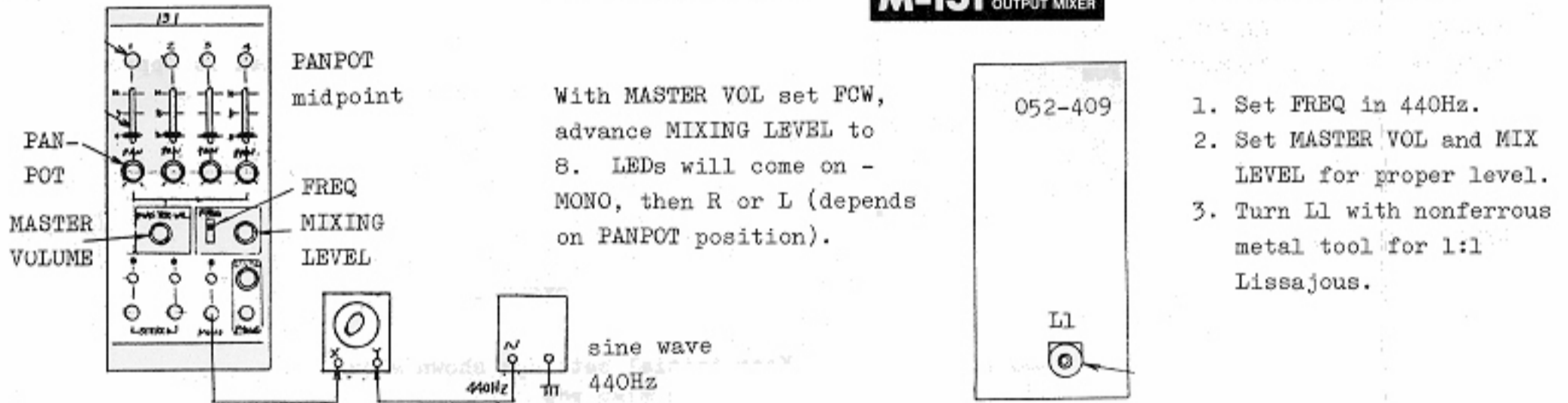

M-132 DUAL CV AUDIO MIXER & VOLTAGE PROCESSOR

VOLTAGE PROCESSOR

MIXER-1.2

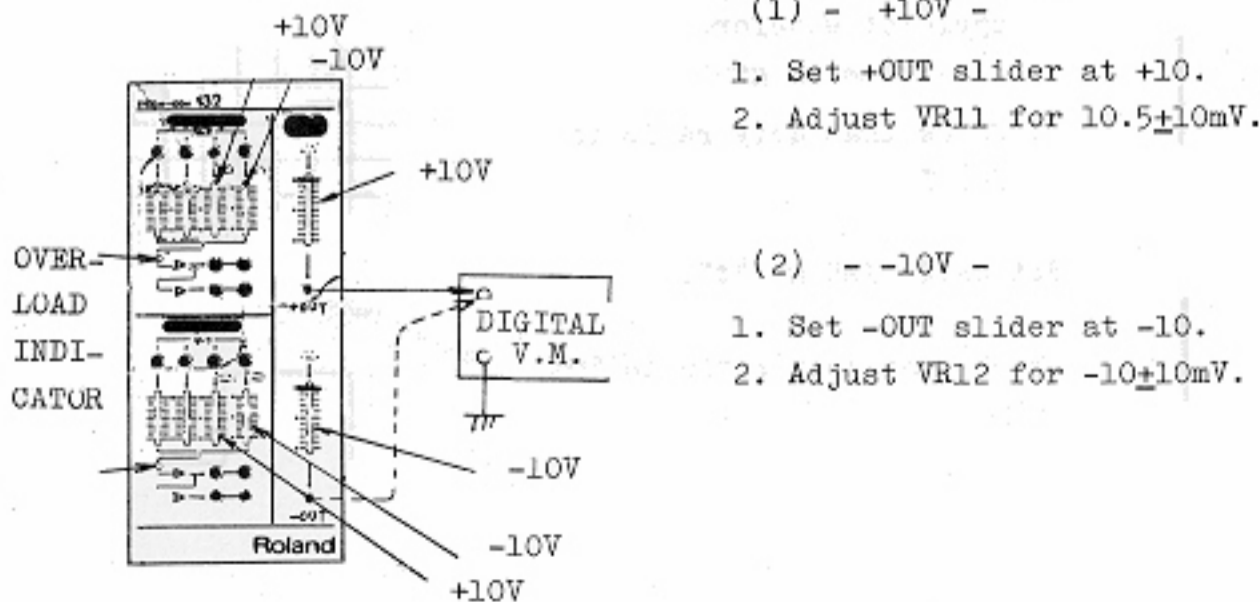

- OVERLOAD INDICATOR -

Check that LEDs light respectively under the following settings.

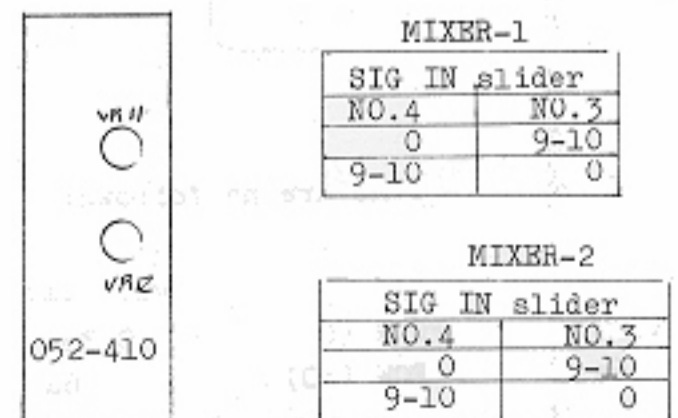

LFO

(1) - FREQUENCY -

Adjust VR1 for 30Hz (33ms).

(2) - AMPLITUDE -

Adjust VR2 for 10V p-p.

Change WAVEFORM to SAWTOOTH.

(3) - SAWTOOTH -

Adjust VR3 for straightness.

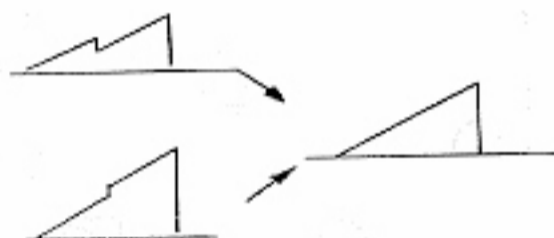
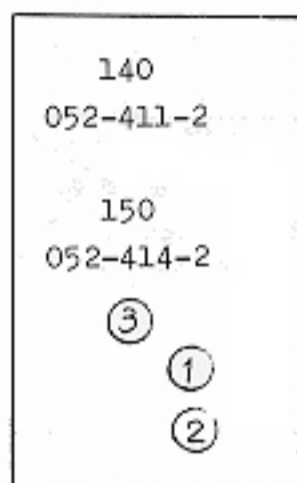
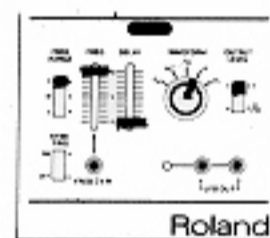

M-150 RING-NOISE S/H LFO

NOISE

Adjust VR1 for 18V p-p.
(early M-150: 12-14V)

RING MODULATOR

(1) - SIGNAL BALANCE -

Insert short-circuit plug into EXT SIG X jack to place a ground to the jack circuit.

Adjust VR2 for minimum RING OUT.

(2) - MODULATION BALANCE -

Connect EXT SIG X to LFO OUT.

Adjust VR3 for distortion free output. Modulated waveform doubles the input in frequency.

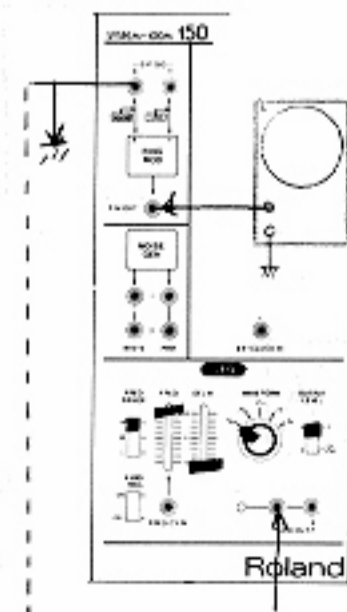
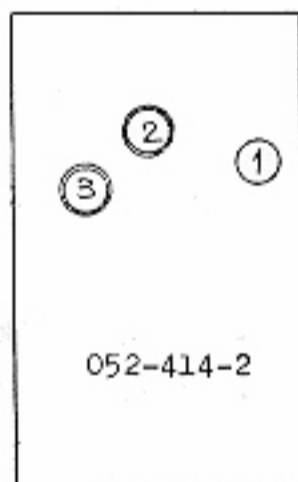
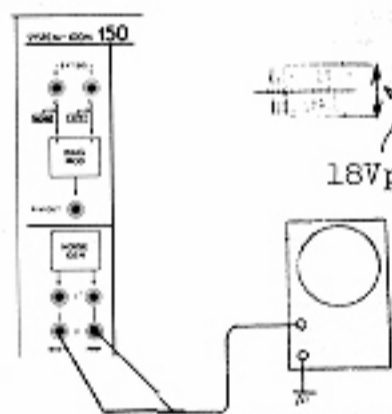

PHASE SHIFTER

- SHIFT FREQUENCY -

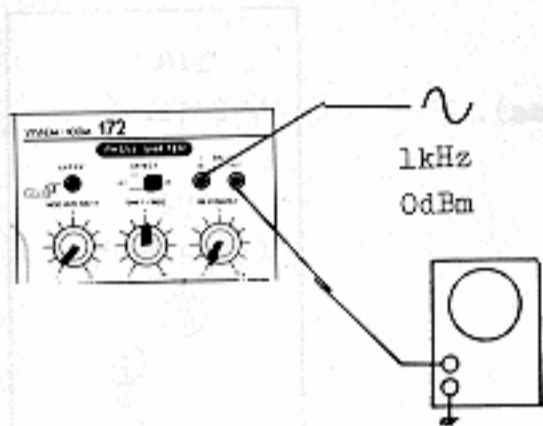

1. Rotate VR1 FCW to/from FCCW; level of PHASE SHIFTER output will decrease to minimum three times per full rotation.
2. Stop the rotation at the 2nd, and fine-tune VR1 for the minimum waveform level.

AUDIO DELAY

(1) - CLOCK -

Connect scope to TP-1.
Adjust VR2 for 20us/cycle.

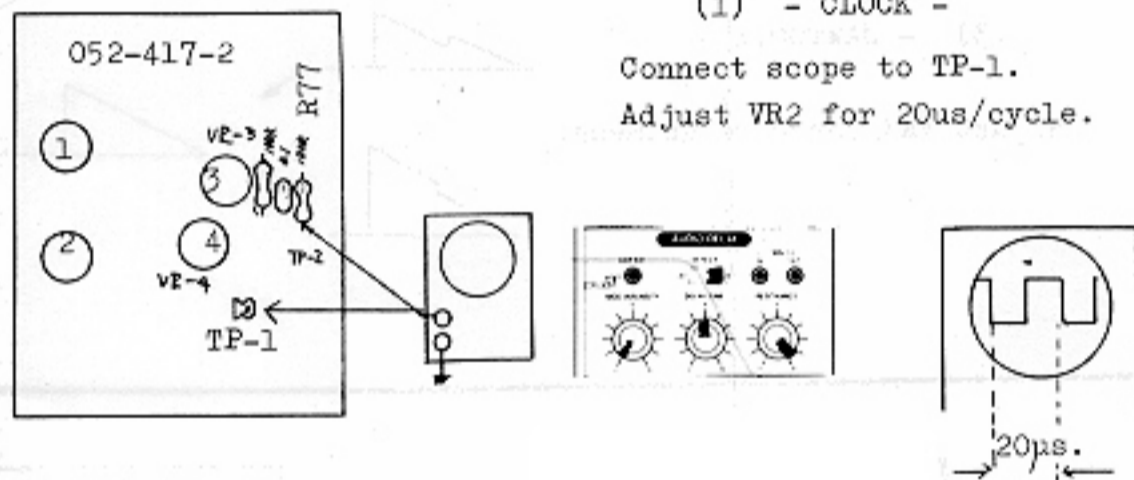

(2) - BBD OUTPUT BALANCE -

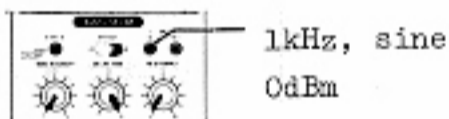

Connect scope to TP-2.
Adjust VR3 for smooth envelope.

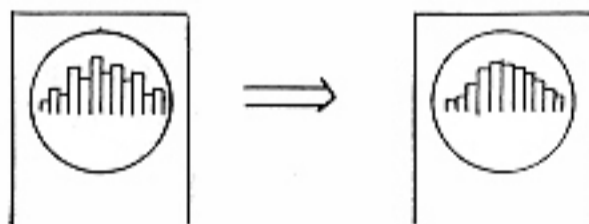

(3) - BBD BIAS -

Connect scope to AUDIO DELAY SIG OUT.
Advance audio generator level control until some distortion occurs.

Free waveform from distortion by turning VR4.

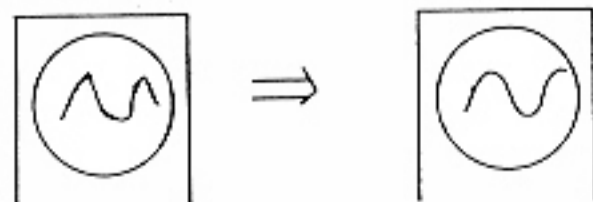

LFO

Check LFO OUTs (A,B) for the following:
Frequency shifts 0.04Hz-10Hz as FREQUENCY a
Amplitude varies with frequency.
10V p-p at 0.04Hz
400mV p-p at 10Hz

Waveforms from OUT A and B are 180° out of each other.

GATE DELAY

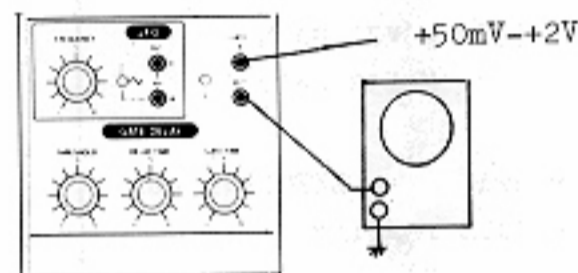

(1) - THR

Check that GATE OUT provides +15V in the fo
input levels and settings:

input +50mV±10% . . . THRESHOLD FC
input +2V±20% . . . THRESHOLD P

(2) - DELAY TIME & GATE TIME -

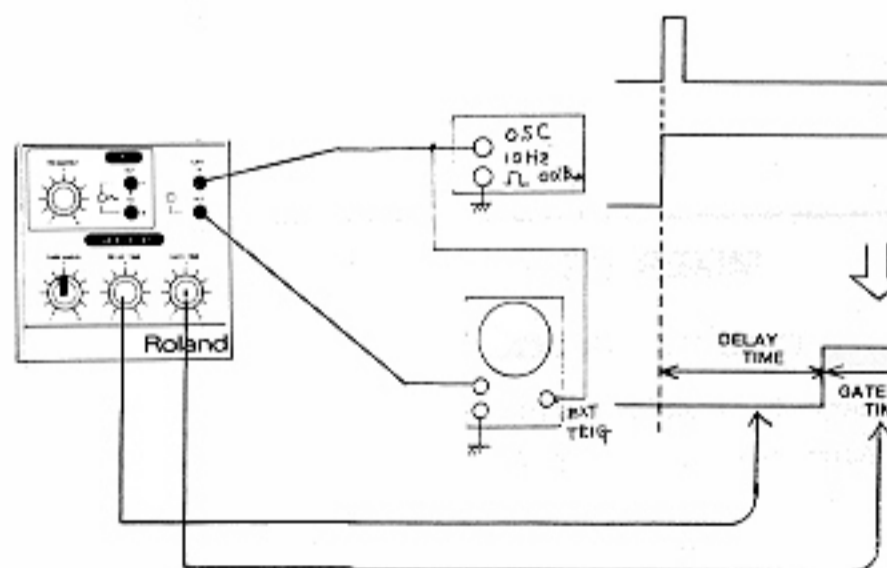

Lengths of DELAY TIME and GATE TIME are as :

DELAY TIME	delay time	GATE TIME
FCCW (0)	0.3ms	FCCW (0)
FCW (10)	6s	FCW (10)

for the following:
 4Hz-10Hz as FREQUENCY advances.
 h frequency.
 4Hz
 0Hz
 and B are 180° out of phase with

E DELAY

+50mV-+2V



(1) - THRESHOLD -

provides +15V in the following
 ings:

- 0% . . . THRESHOLD FCCW
- . . . THRESHOLD FCW

IME & GATE TIME -

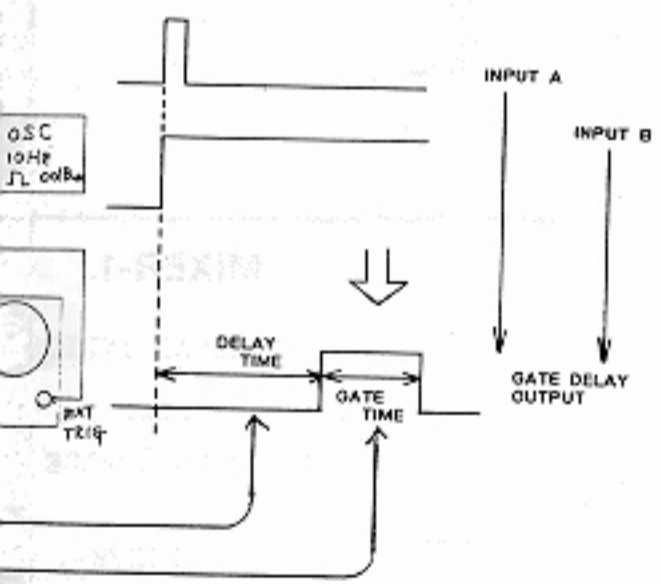

and GATE TIME are as follows:

me	GATE TIME	gate time
FCCW (0)		0.3ms
FCW (10)		6s

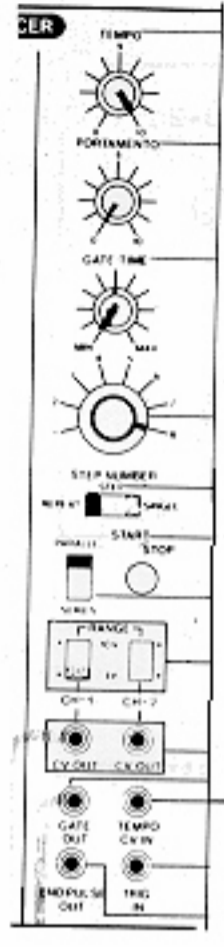

GATE

(1) - TEMPO -

Set controls as illustrated at left.

Adjust VR20 for:

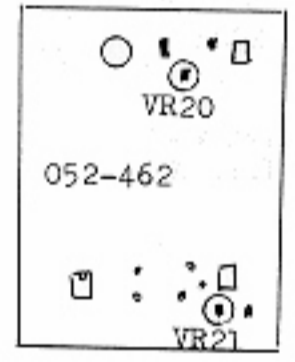
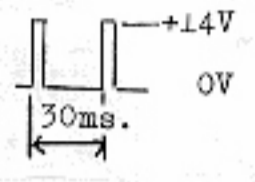

(2) - LED ON/OFF TIMING -

With TEMPO at "0", a LED stays on for 7 seconds before the next LED lights.

With TEMPO at "5", LED lighting duration is approximately 0.5 seconds.

(3) - DUTY CYCLE -

Keep initial settings shown above. Turn GATE TIME FCW.

Adjust VR21 for 90±2% duty ratio.

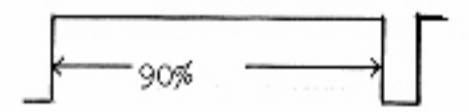

Reverse GATE TIME (FCCW).

1. Adjust TEMPO to display one cycle of waveform across ten divisions on graticule.
2. Check that duty ratio is 8-12%.

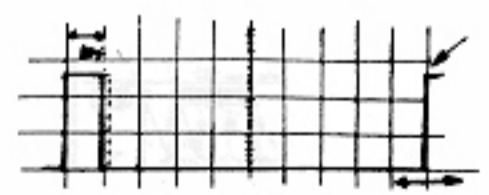

Set GATE TIME at "4".

Check that duty ratio is 50% (±7%)

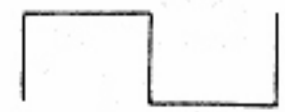

M-190 M-191J

- PS-46B (146-046B) 100V
- PS-47B (146-047B) 117V
- PS-48B (146-048B) 220/240V
- (pcb 052-421B)

M-191J OPH53 (149H053) (pcb 052-423)

JACKS HSJ040Q-01-020

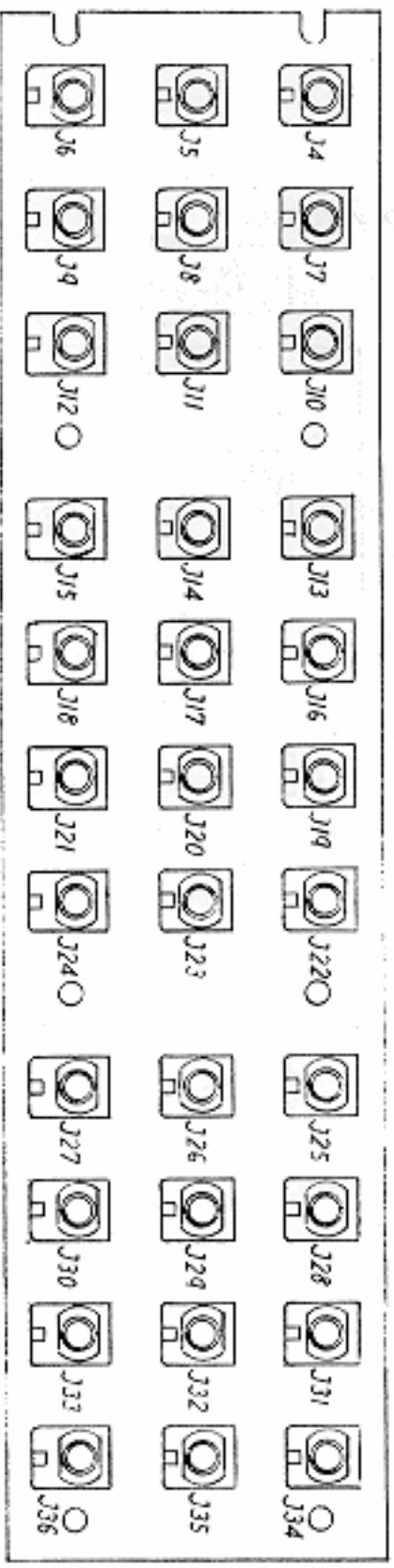

IC-	1	15119110F0	TA7179M	100/117V	220/240V
Q-	1	15119800	2SB434-0		
Q-	2	15129801	2SD234-0		
D-1-4		15019210	1R5BZ61 or 1N4003	1.5A 100V	
D-	5	019-020	LR0601R	LED	
VR-	1	13299117	SR19R	100KB	
R-	1,2	044-589	ERG-01AND	0.82 ohms	1/2W
P.T.		022H025J	100V		
		022H025C	117V		
		022H025D	220/240V		

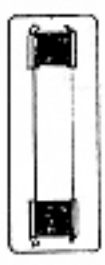

Fuse holder
012H022 F-3265

Fuse holder
12199516 S-N5054

F- 1-3

F- 1

12559114 MGC 1.0A 100V

12559301 MGC0001 117V

12559511 CBB 1500mA

12559513 CBB 11A

HS- 1, 2 046-052 Heat sink no.52

TA7179M

Pin numbers in parentheses are for the plastics type TA7179P only.

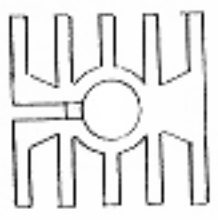

ABSOLUTE MAXIMUM RATINGS (T=25°C)

Input voltage	(+) (-) 30V
Output current	(+) (-) 100mA
Power dissipation	500mW
Operating temperature	-30°C+75°C

ROUTING CIRCUIT

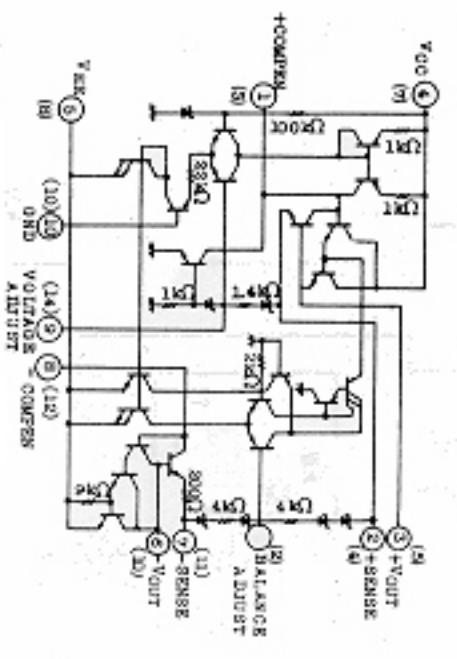

EXPANDER MODULE-1 MODULE-2 TRIG GATE MODULE-3 MODULE-4 MODULE-5

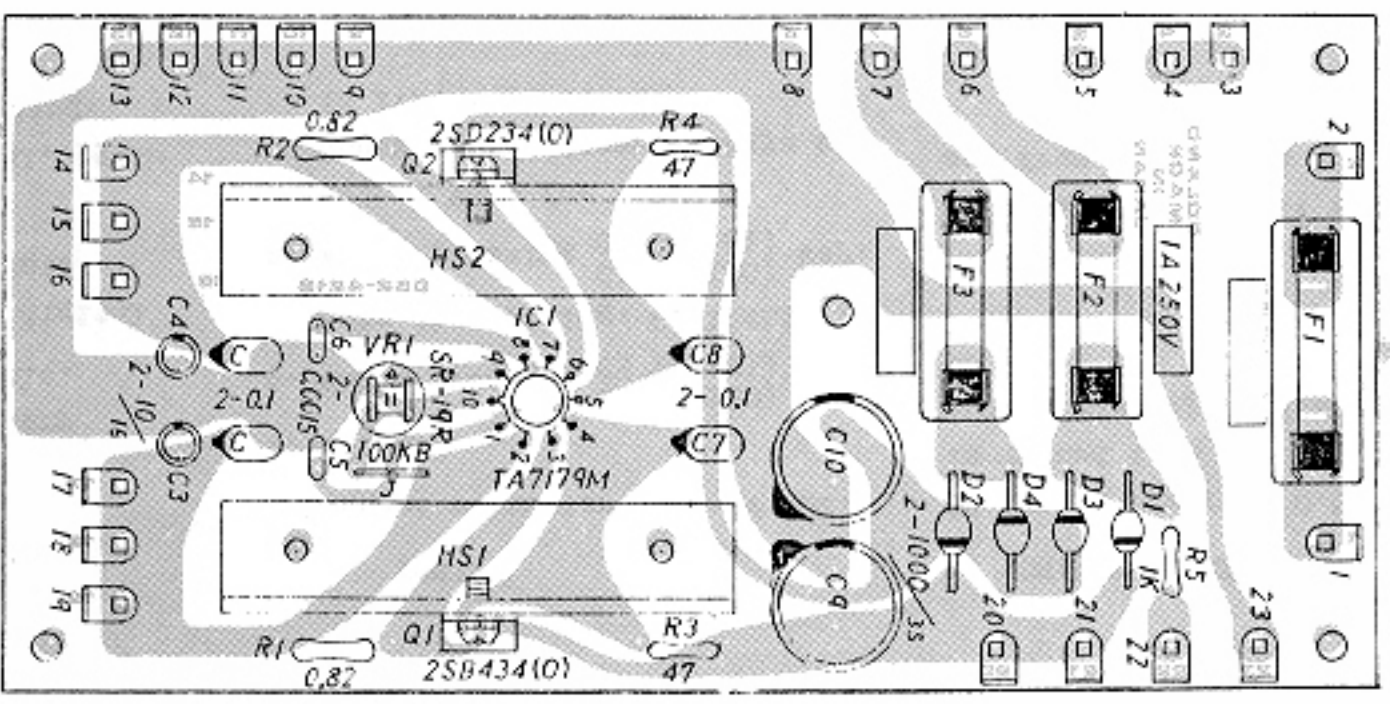

EXPANDER

MODULE-1

MODULE-2 TRIG

MODULE-3

MODULE-4

MODULE-5

MODULE-4
MODULE-5

M-191J only

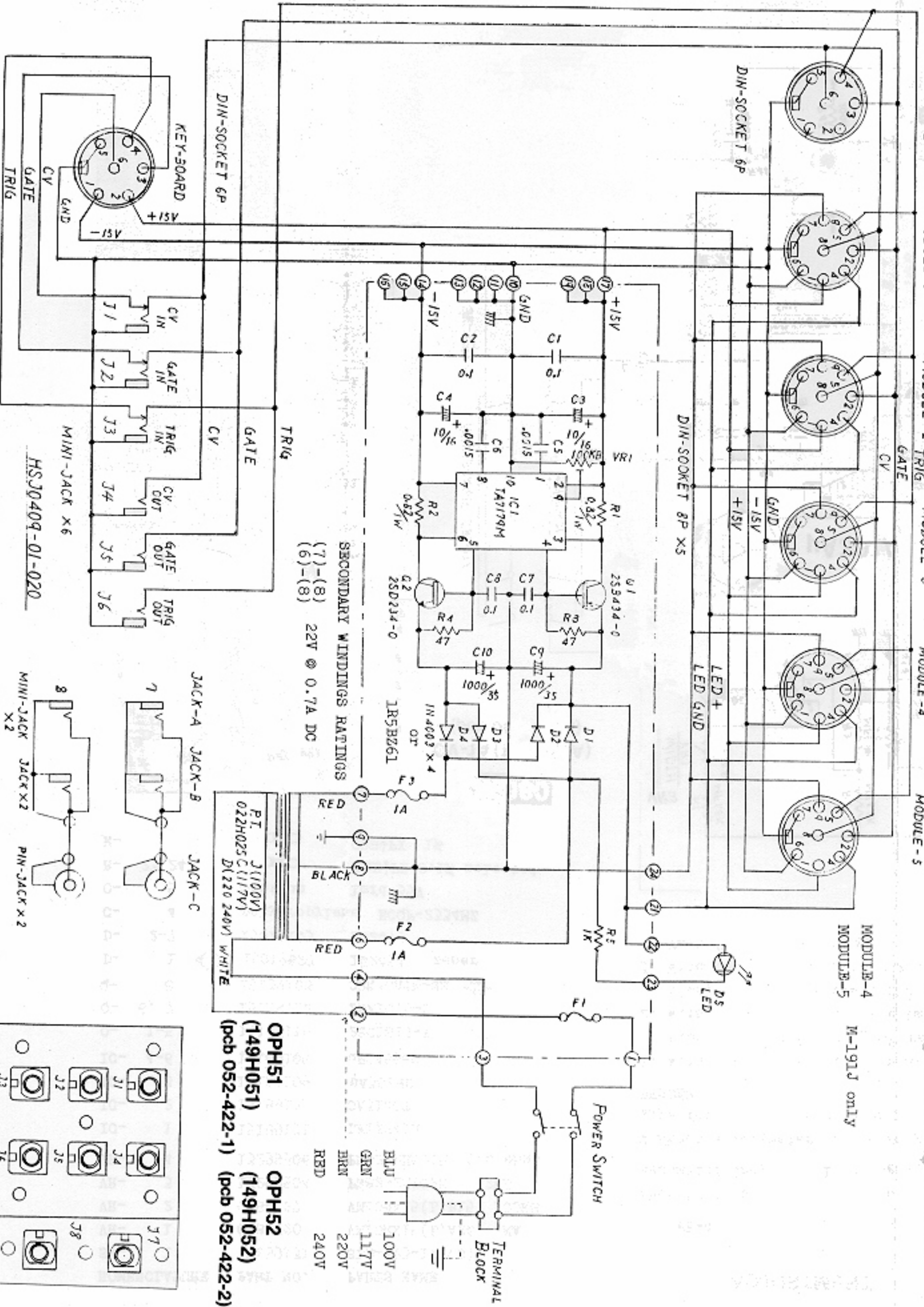

SECONDARY WINDINGS RATINGS
 (7)-(8) 22V @ 0.7A DC
 (6)-(8)

OPH51 (149H051)
 OPH52 (149H052)
 (pcb 052-422-1) (pcb 052-422-2)

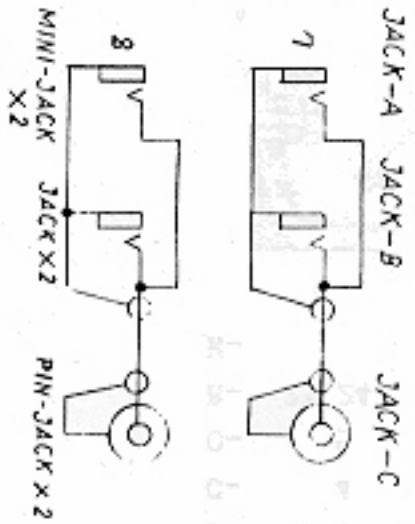

HSJ0409-01-020

NOMENCLATURE	PART NO.	PARTS NAME
SW- 1	13139131	SLE-623-12P(S)
VR- 1	028-720	VM10RK15(L)A26 2MA
VR- 2	028-727	VM10RK15(L)B15 100KB
VR- 3	13299504	PN82-2H202H 2KB
VR- 4	13299506	PN82-2H501H 500 ohms
IC- 1	15189131	LF13741H
IC- 2	15189121	CA3140T
IC- 3	15189109	uA301HC
IC- 4-6	15189105	uPC4558C
Q- 1-5	15129115	2SC1815-Y
Q- 6, 7	15119112	2SA1015-Y
Q- 8	15139103	2SK30ATM-GR
D- 1	15019627	1S2454 zener
D- 2-7	15019103	1S2473
C- 4	polypropylene	ECQF-2334MZ
C- 5	tantlum	1mfd 35V
R- 23,24		CRB $\frac{1}{2}$ FX 0.1% selected
R-		CRB $\frac{1}{2}$ FX 1%

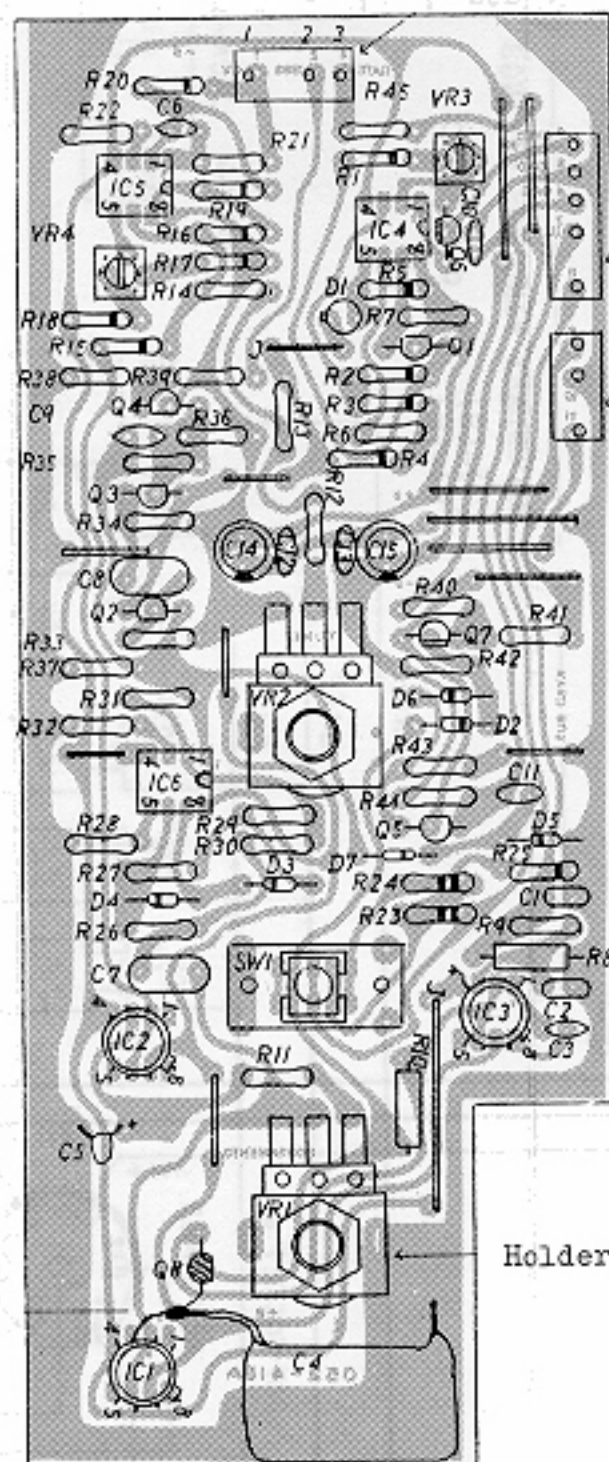

M-180
CV-1A (159-001A)
(pcb 052-418A)

KEY-BOARD 32NOTE
SK-132B

Holder N-106
(H55A)

ADJUSTMENT

PB-4 (M-181 only)

When PB-4 is replaced with a factory assembled one, step 1 is negligible.

Connect a voltmeter (preferably, digital type for precise measurements) into BENDER OUT jack.

1. With PB-4 lever left at neutral, position VR-5 wiper for 0 \pm 1mV reading.
2. With the lever held at leftmost position, set VR-7 on OP-98 for -5V reading.
3. With the lever held at rightmost, set VR-6 for +5V reading.

TUNING

Connect vo

1. WIDTH
 - a. While pre
 - b. While pre
 - c. Check the
- note the
in 1V/oct

2. SHIFT

While pressi

VR-4 for 2V
3V

Tunable range
 \pm 700 cents
Portamento
0-10s

GATE
GND

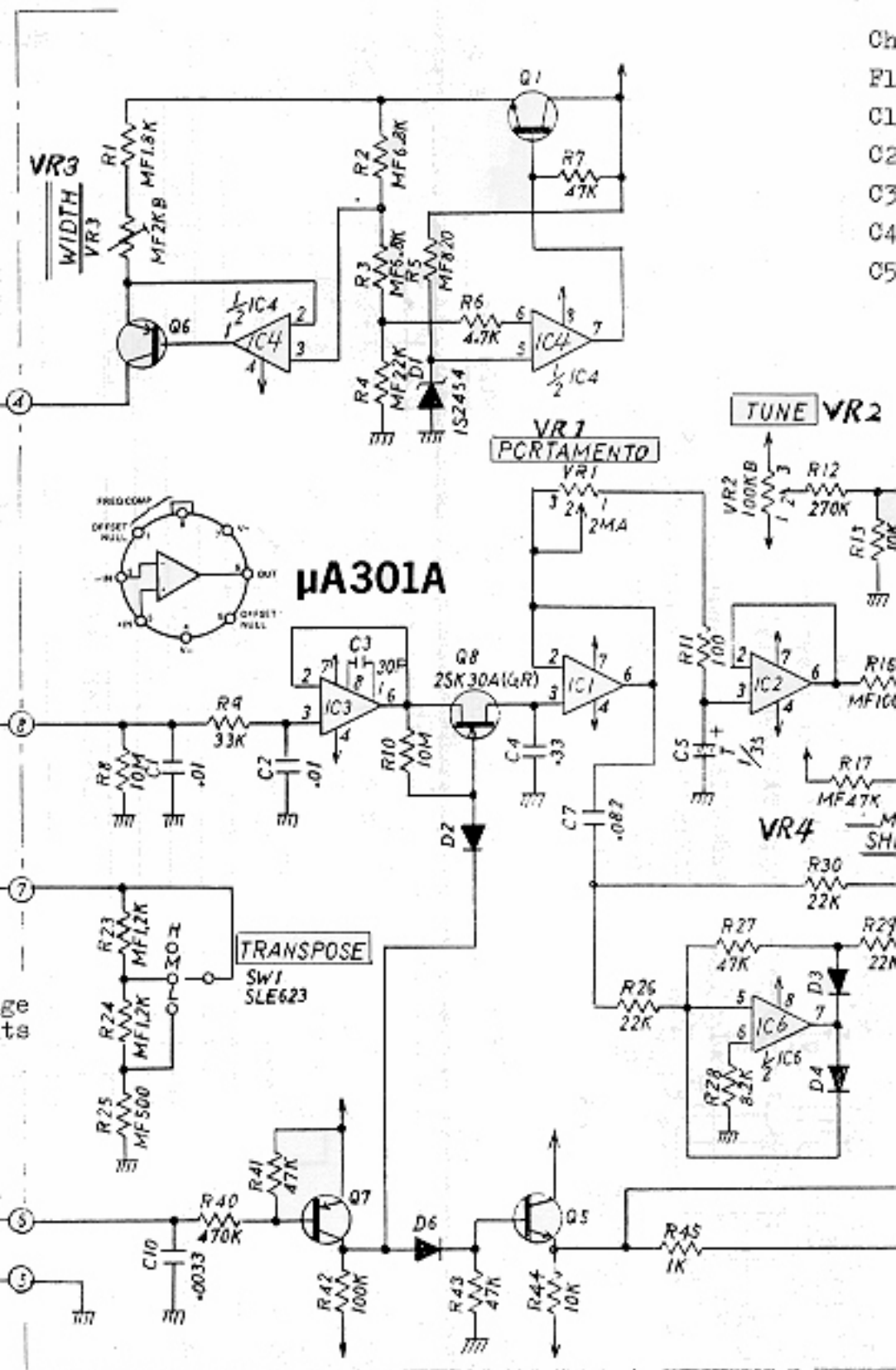

FOR KEY DESIGNATIONS, SEE P. 12.

TUNING

Connect voltmeter into CV OUT.

1. WIDTH
 - a. While pressing C2 (M-180) key, note the reading. Call this Vx.
 - b. While pressing C3 (M-180) key, adjust VR-3 for Vx + 1V.
 - c. Check that adjacent C keys are in 1V/oct relation.

2. SHIFT

While pressing C2 (M-180) key, set C3 (M-181)

VR-4 for 2V reading.

Check:

- F1 = 1.416V (M-180)
- C1 = 1V (M-181)
- C2 = 2V
- C3 = 3V
- C4 = 4V
- C5 = 5V (M-181)

current draw
40mA +15V
20mA -15V

3. TUNABLE RANGE

CV should lower by 0.5V when TUNING VR-2 is turned from 0 point to FCCW, and should rise by 0.5V when VR-2 turned 0 to FCW.

4. TRANSPOSE

CV should vary by 1V when TRANSPOSE is set from M position to L or H.

5. PORTAMENTO

(M-181 - SW-2 on -)

Turn PORTAMENTO fully clockwise.

- a. Press the lowest key, then, the upmost key. The time required for CV to reach the voltage specified by latter key is 23s.
- b. Reverse the above key pressing order. The time is also 23s.

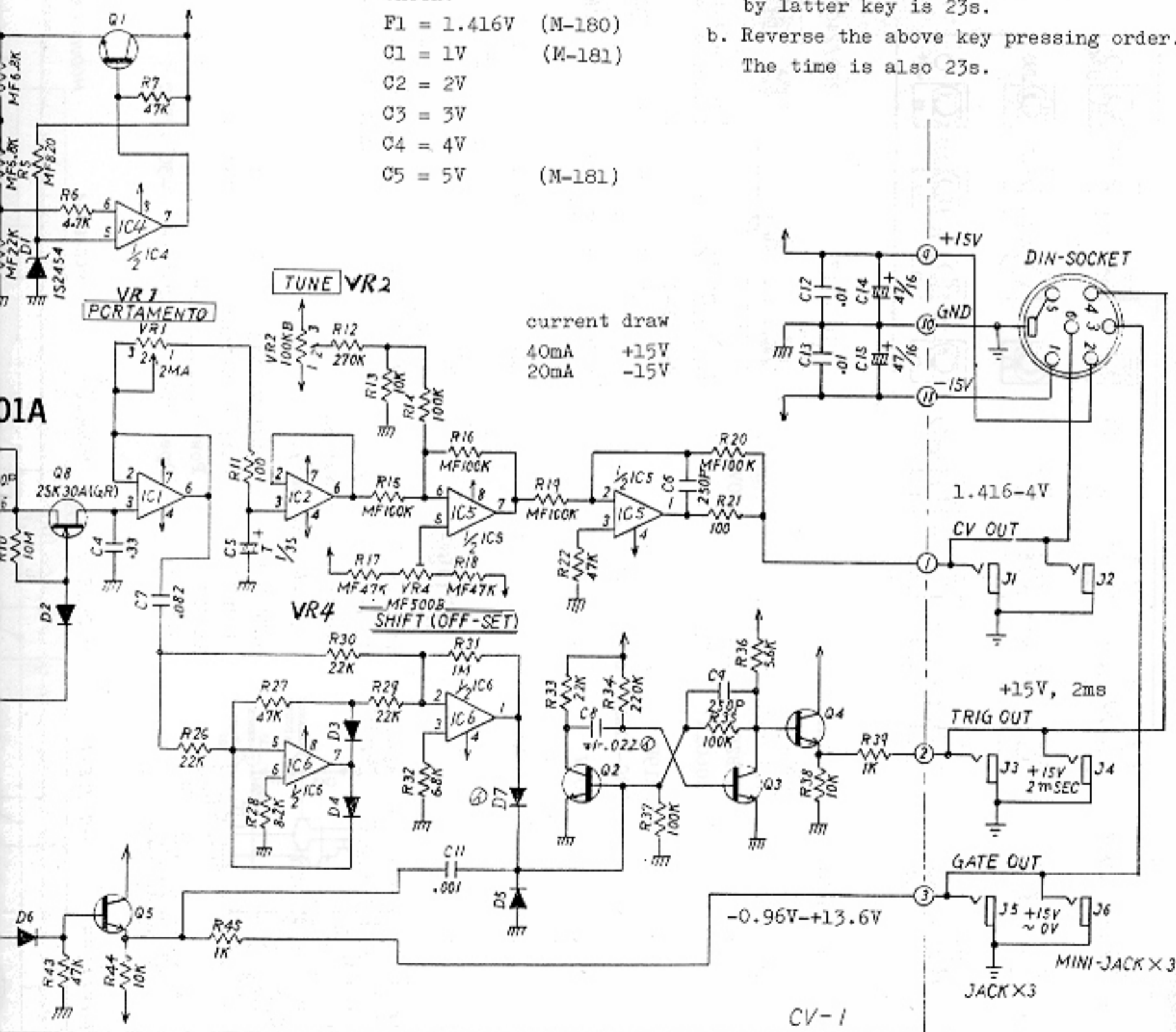

Q-	1-5	15129115	28C1815-Y
Q-	6, 7	15119112	28A1015-Y
Q-	8	15139103	28K30ATM-GR
D-	1	15019627	182454 zener
D-	2-7	15019103	182473
R-	25, 26		CRB $\frac{1}{2}$ FX 0.1% selected
R-			CRB $\frac{1}{2}$ FX metal film
C-	3	polypropylene	BCQF-2334MZ 0.33mfd
C-	4	tantalum	lmfd 35V

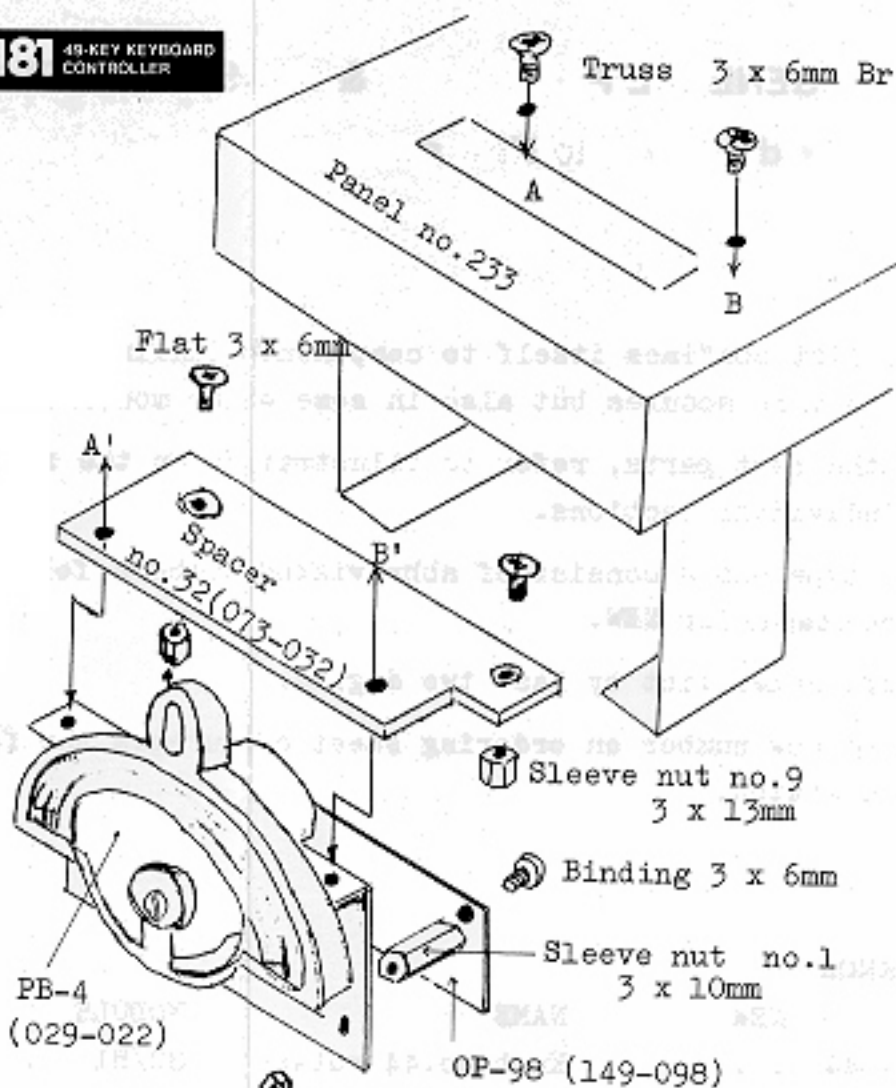

OP98 (149-098)
(pcb 052-420)

M-181

CV2A (159-002A)
(pcb 052-419A)

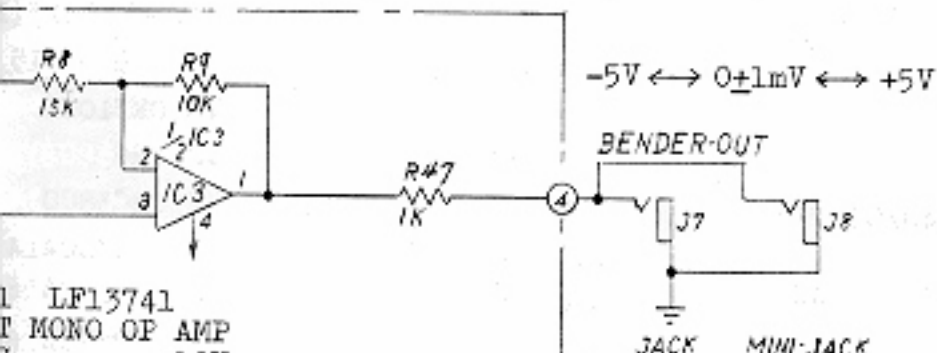
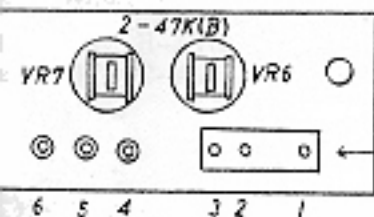

current draw
40mA +15V
20mA -15V

LF13741
MONO OP AMP
... +18V
... 500mW

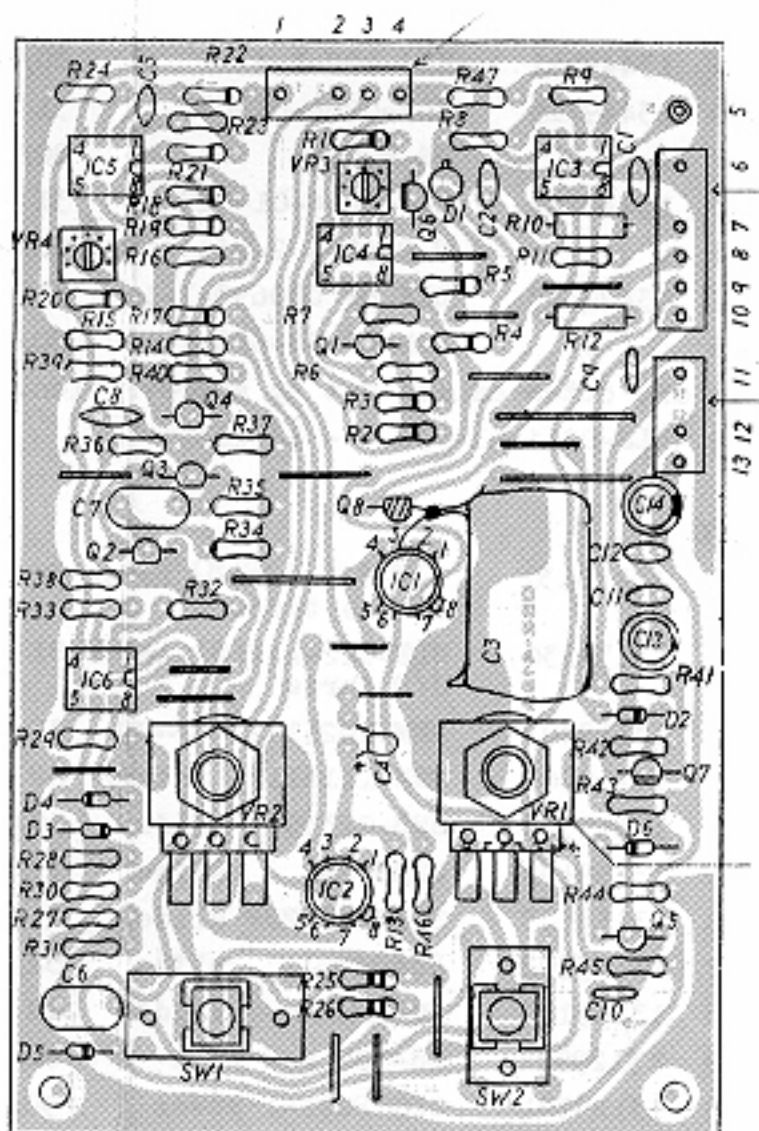
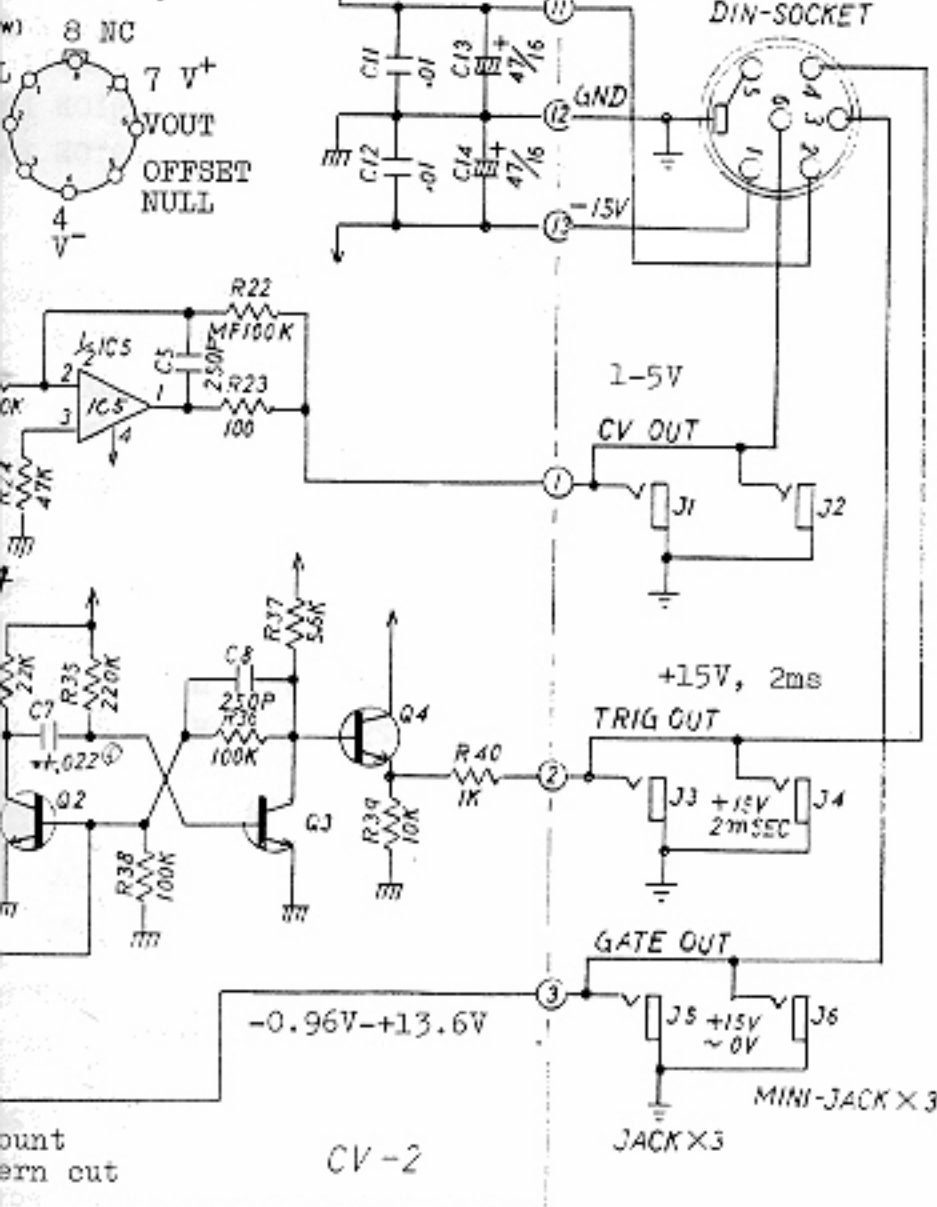

6. TRIG OUT

While depressing a key, tap the lower key. This keyings should cause TRIG OUT to send out pulses each time the contact closes and opens.

CA3140
 MOS/FET Input Bipolar Output
 DC Supply Voltage . . . 36V
 (Between V⁺ and V⁻ terminals)
 Differential-mode Input Voltage . . . +8V
 Input Terminal Current . . . 1mA

NOMENCLATURE	PART NO.	PARTS NAME
SW-	1	13139131 SLE-623-12P(S)
SW-	2	13139130 SLE-622-12P(S)
VR-	1	028-720 VM10RK15A26 2MA
VR-	2	028-727 VM10RK15B15 100KB
VR-	3	13299504 PN82-2H202H 2KB
VR-	4	13299506 PN82-2H501H 500
VR-	5	029-022 PB-4 assy
VR-	6, 7	13299116 SR19R 47KB
IC-	1	15189131 LF13741H OP amp
IC-	2	15189121 CA3140T
IC-	3-6	15189105 uPC4558C

Q-	1-5	1
Q-	6, 7	1
Q-	8	1
D-	1	1
D-	2-7	1
R-	25, 26	
R-		
C-	3	pa
C-	4	ts

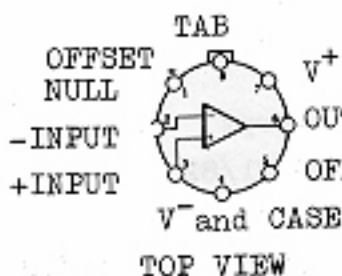

KEY-BOARD 49NOTES SK-192B

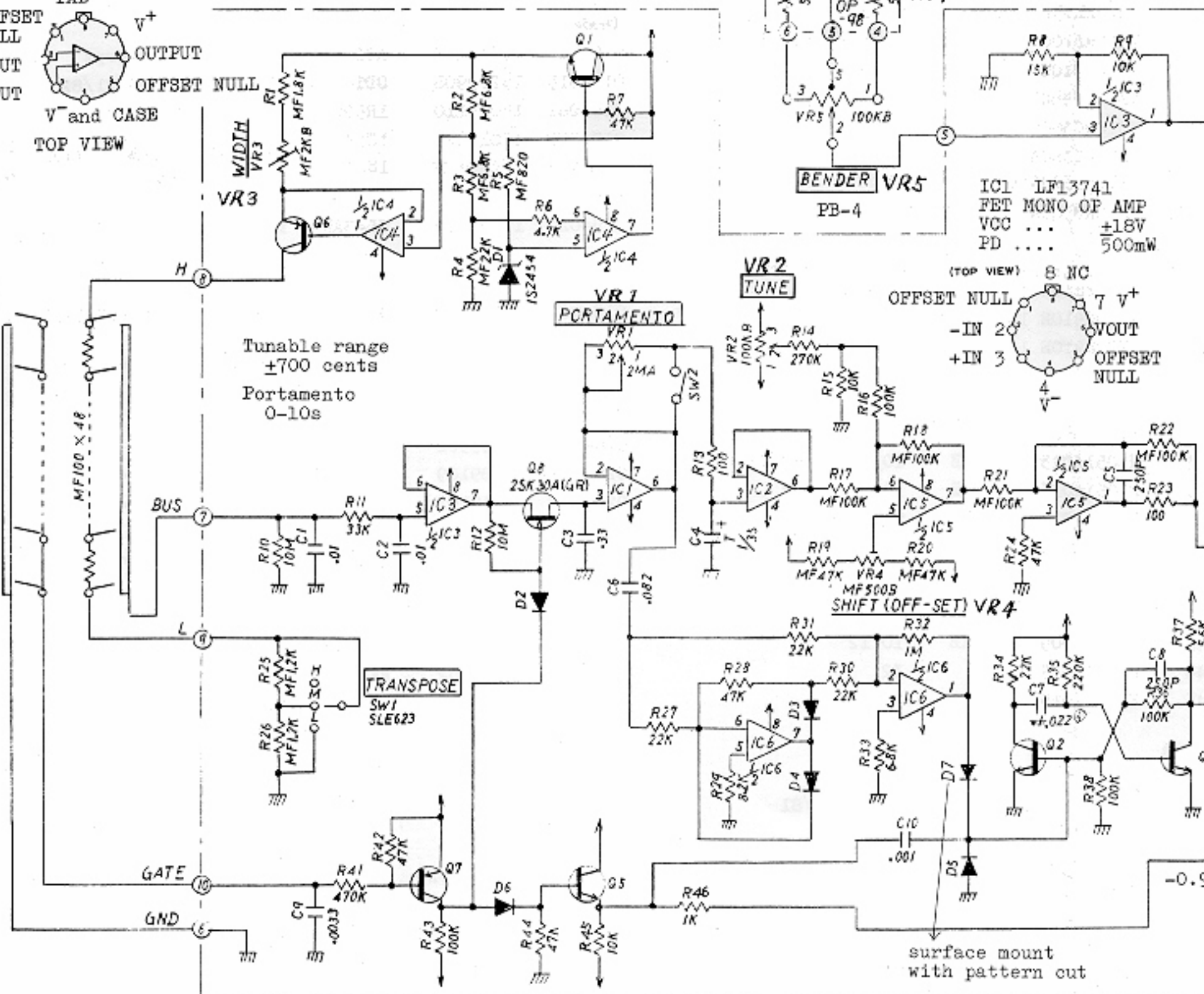

GENERAL PARTS LIST & CROSS-REFERENCE

Old number to New number

This list confines itself to components finding applications not only in modules but also in some other models.

For the rest parts, refer to illustration on the front cover or individual sections.

Some type names consist of abbreviated numbers following N- which stands for NEW.

Module names list by last two digits.

Use of new number on ordering sheet encourages the factory for dispatch.

KNOB			
OLD	NEW	NAME	MODULE
016-044	. . .	Knob no.44 rotary	80/81
016-077	2247012700	Knob N-127 rotary	31/82
016-078	2247012800	Knob N-128 rotary	10/12/30/31/40/50/72/82
016-079	2247012900	Knob N-129 slide	10/12/21/30/31/32/40/50

JACK. SOCKET			
OLD	NEW	NAME	MODULE
009-039	13449402	SJ-409-1-2	10/12/21/30/31/32/40/50/72/82/90/91
009-015	13449111	HLJ-102-1-4	80/81/90/91
009-030	13449115	HLJ-0264-01-030	31
009-007	. . .	SG-8050#4	80/81
009-040	13449114	HLJ-0264-01-020	31
009-016	. . .	P-254P-4 2-pin	90/91
012-037	13429603	DIN 8P CS0690-1-1	all but 90/91
009-036	. . .	DIN 6P CS-660-1-1	80/81/90/91

*Jacks are often called out by abbreviation. So are switches.
exp. HLJ-0264-01-030 --- LJ-264-1-3

SWITCH			
OLD	NEW	NAME	MODULE
. . .	13139131	SLE-623-12P(S) lever single throw	80/81
. . .	13139130	SLE-622-12P(S) lever U/D throw	81
001-214	13119401	SRM-1025172 rotary	10/12/40/50
001-272	13119702	SRM-1018112 rotary	82
001-183	13159304	SSB-02335 slide	10/12/40/50
001-182	13159103	SSB02242 slide	12/30/40/50/72
001-228	13159503	SQPR240120P slide	21/31 (abbr. SQPR24-12P)
001-177	13159302	SSA04301 slide	82
001-176	13159102	SSA04202 slide	82
001-049	13129901	DS-102 red push	40/82
001-215	13129101	SDG5P001-1 power	90/91 100W
001-216	13129102	SDG-5P001-2	90/91 117W
001-217	13129103	SDG5P502	90/91 220/240V

OLD NO. NEW NO. PART NAME MO

POTENTIOMETER

Slider

029-519	13339301	EVA-HO4C15A15	100KA	10
029-521	13339305	EVA-HO4C15A55	500KA	50
029-522	13339302	EVA-HO4C15A16	1MA	50
029-531	13339304	EVA-HO4C15B15	100KB	10
029-523	13339303	EVA-HO4C15A26	2MA	40
029-543	13339401	EVA-TOAC15A15	100KA	10
029-555	13339402	EVA-TOAC15B15	100KB	10
029-570	13339403	EVA-TOAC15D16	1MD	40
029-571	13339404	EVA-TOAC15D26	2MD	40
029-022	. . .	PB-4 assy		81
		EVA-H	20mm stroke	
		EVA-T	30mm storke	

Rotary

028-720	. . .	VM10RK15A26(L)	2MA	80
028-727	. . .	VM10RK15B15(L)	100KB	80
028-763	13219220	VM10RB10CB15	100KB	10
028-762	13219219	VM10RB10CB54	50KB	72
028-760	13219225	VM10RC38CB14	10KB	72
028-774	13219226	VM10RC38CC15	100KC	72
028-749	13219222	VM10RC38CA14	10KA	72
028-756	13219221	VM10RC38CA26	2MA	72
028-755	13219223	VM10RC38CA16	1MA	82

*VM10RC38C/10RB10C shaft: K-20 (20mm length)
GM70R910E terminal: L shaped pc

028-664	13219806	GM70R910E	100KA/100KC
028-665	13219807	GM70R910E	100KB x 2

Trimmer

Carbon solid formerly named as "SR19R"				
030-465	13299114	H1051A013	10KB	10
030-467	13229115	H1051A015	22KB	10
030-469	13299116	H1051A016	47KB	72
030-471	13299117	H1051A019	100KB	10

Metal glaze formerly named as "CR19R"

030-491	13299542	H1021A009	2.2KB	10
030-497	13299544	H1021A015	22KB	32
030-501	13299546	H1021A019	100KB	5

Tantalum thin film

030-625	13299501	PN822H101H	100B	10
030-630	13299504	PN822H202H	2KB	10
030-631	13299506	PN822H501H	500B	80
030-632	13299507	PN822H502H	5KB	10
030-636	13299508	PN822H503H	50KB	10

Zener diodes 1S2453, 1S2454

Application is thermal drift compensates. This part indicates identical electrical characteristics. This part is provided with low temperature coefficient. This part may be a good replacement for 1S2453.

NAME	MODULE	OLD NO.	NEW NO.	PART NAME	MODULE
SEMICONDUCTOR					
Transistor					
H04C15A15	100KA	10/12/21/30	017-010	15129801 2SD234-0	90/91
H04C15A55	500KA	50	017-012	15119106 2SA733-Q	72/82
H04C15A16	1MA	50	017-013	15129107 2SC945-Q	72/82
H04C15B15	100KB	10/12/21/30/32/40/50	017-016	15139103 2SK30ATM-GR FBT	10/21/30/40/50/80/81/82
H04C15A26	2MA	40/50	017-0168	15139103A "SK30ATM-GR selected on gm base	72
POAC15A15	100KA	10/21	017-022	15119800 2SB434-0	90/91
POAC15B15	100KB	10/21/31/32/40	017-039	15139110 NF510	10/12
POAC15D16	1MD	40	017-046	151291050A 2SC828R NZ selected	50
POAC15D26	2MD	40	017-105	15119112 2SA1015-Y	10/12/21/30/31/32/40/50/80/81
assy		81	017-110	15129115 2SC1815-Y	10/12/21/30/31/40/50/80/81
H 20mm stroke			017-124	15119108 2SA798-G	82
T 30mm storke					
RK15A26(L)	2MA	80/81			
RK15B15(L)	100KB	80/81			
Diode					
RB10CB15	100KB	10/12/30/31/72	018-014	15019103 1S2473	except 90/91
RB10CB54	50KB	72/82	018-015	15229908 SDT-1000 thermistor	10/21/82
RC38CB14	10KB	72	018-061	15019210 1R5BZ61 100V 1.5A	90/91
RC38CC15	100KC	72	018-078	15019625 1S2453	10/12
RC38CA14	10KA	72	018-079	15019627 1S2454 zener 6-7V 250mW @ 10mA	80/81
RC38CA26	2MA	72		see below center	
RC38CA16	1MA	82			
LED					
			019-020	15029109 GL-3AR-2 red	72/82
				LR0601R red	90/91
				* LR -- longer leads	
			019-022	15029110 GL-3AR-1 red	10/12/21/30/31/32/40/50
			019-023	15029111 GL-3PG-1 green	10/21/30
IC					
			020-001	15199502 TA-7066AP	31
			020-024	15189109 uA301HC	10/31/80
			020-032	15219101 uA726HC	10/12
			020-040	15159104T0 TC4011BP	82
			020-041	15159105T0 TC4013BP	31/72/82
			020-063	15219203 MN3004 BBD	72
			020-026	15219106 LM1496N	50
			020-096	15229803 BA662B	10/30/40/50
			020-160	15229802 BA662A	10/21
				*BA662A can replace BA662B	
			020-097	15189105 uPC4558C	all except 90/91
			020-100	15189118 TL082CP	10/12/40/50/82
			020-105	15189121 CA3140T	82/80/81
			020-152	15189102 NJM4558DD	72
			020-165	15219109 NE-555P	72
			020-167	15159107Z0 MC14022B	82
			020-194	15159102T0 TC4001UBP	82
			020-228	15199110T0 TA7179M	90/91
			. . .	15189131 LP1374H	80/81

es 1S2453, 1S2454
thermal drift compensation. Although
al electrical characteristics, 1S2454
low temperature coefficient and can
ment for 1S2453.