

ELECTRONIC MUSICAL INSTRUMENT

**RHYTHM ARRANGER
TR-66**

**SERVICE
NOTES**

THE SECOND EDITION
Printed in Japan '76. Nov

 **Roland**

CONTENTS

SECTION 1. SPECIFICATIONS	2
SECTION 2. DISASSEMBLING	2
SECTION 3. GENERAL BLOCK DIAGRAM	3
SECTION 4. LOGIC CIRCUIT	4
SECTION 5. MATRIX CIRCUIT	4
SECTION 6. RHYTHM SWITCH ASSEMBLY (RS-9)	6
SECTION 7. RHYTHM SWITCH ASSEMBLY (RS-6)	8
SECTION 8. VOICE GENERATOR AND POWER SUPPLY	10
CIRCUIT	
SECTION 9. RHYTHM ENSEMBLE PATTERN	12
SECTION 10. ADJUSTMENT	17
SECTION 11. PARTS LIST	24

SECTION 1. SPECIFICATIONS

- * RHYTHMS : 27 --- WALTZ, JAZZ WALTZ, SLOW ROCK, BOSSA-NOVA, SAMBA, MAMBO, CHA-CHA, BEGUINE, RHUMBA.
"ROCK Beat"
ROCK-1, ROCK-2, ROCK-3, ROCK-4 and ROCK-6.
"2 Beat"
BASS and SNARE DRUM, FOX TROT-1, SWING-1, MARCH, PARADE, HABANERA.
"4 Beat"
BASS and SNARE DRUM, FOX TROT-2, SWING-2, SWING-3, SHUFFLE, TANGO.
- * RHYTHM MODE SELECTOR (ARRANGEMENTS) : VARI. A
AUTO
VARI. B
- * VOICES : 10 --- BASS DRUM, HIGH CONGA, LOW BONGO, HIGH BONGO, COW BELL, RIM SHOT, CLAVES, SNARE DRUM, HI-HAT(MARACAS), CYMBAL.
- * CONTROLS : VOLUME(With power switch), BALANCE, TEMPO RATE, START/STOP.
- * PILOT LAMP : LED(Used as both power and tempo pilot lamp.)
- * OUTPUT JACK : HIGH IMPEDANCE --- 100K.250PF
LOW IMPEDANCE --- 10K ohms
- * FOOT SWITCH JACK : START/STOPfor DP-1
- * AC VOLTAGE : 100V, 117V, 220V, 230V, 240V, 50/60 Hz
- POWER CONSUMPTION : 4 W
- * DIMENSIONS : 230mm(W) x 267mm(D) x 162mm(H)
- * WEIGHT : 4 Kgs
- * CABINET FINISH : PRINTED PLYWOOD FINISH
- * ACCESSORY : CONNECTION CORD (2.5m with Pin-Plug adaptor)

SECTION 2. DISASSEMBLING

Remove 4 screws on the bottom, and the chassis can be pulled out of the cabinet.

Note : The manufacture holds the right of changing any kind of component parts for improvement with or without previous notice.

SECTION 3. GENERAL BLOCK DIAGRAM

Fig. 1

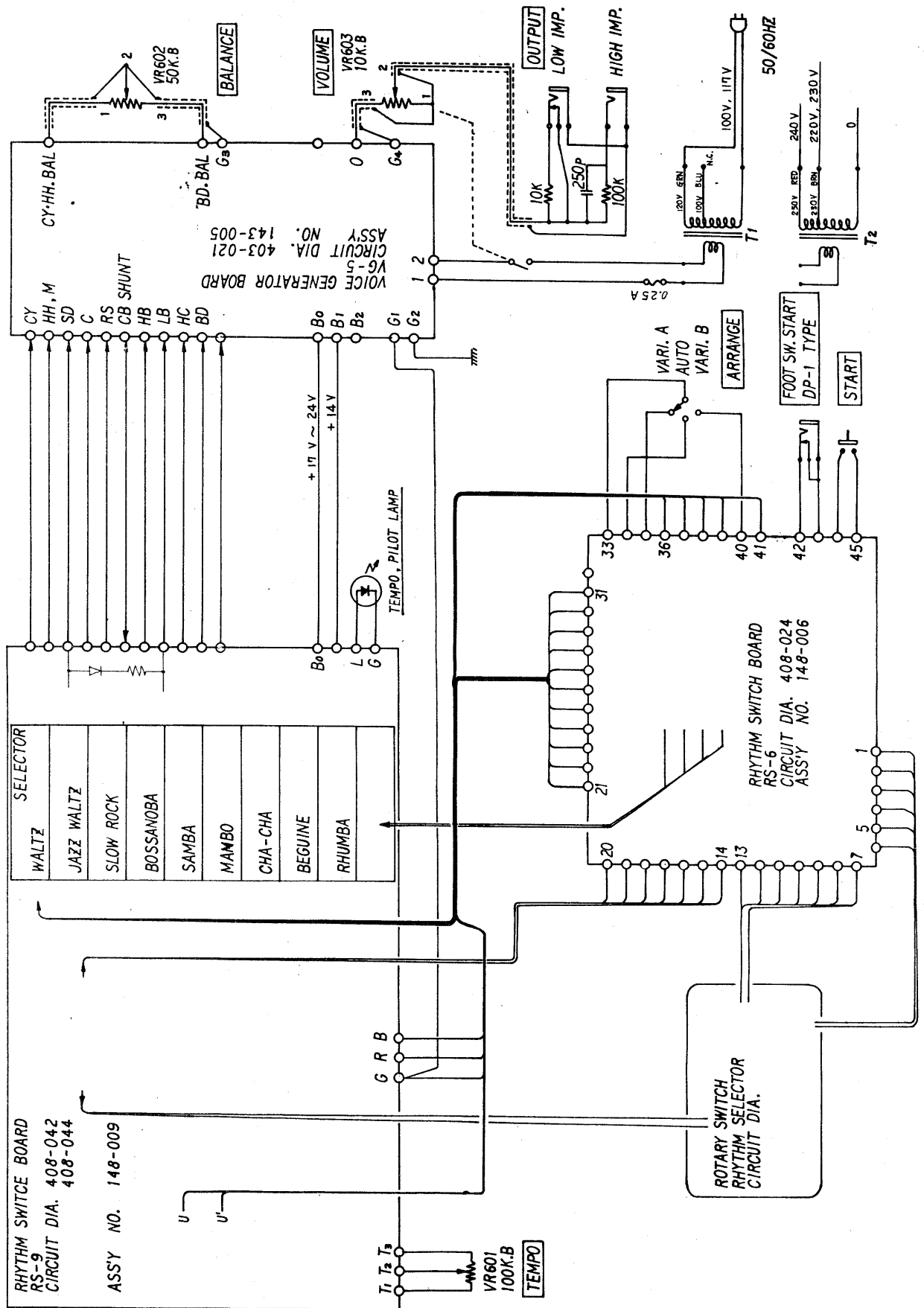

SECTION 4. LOGIC CIRCUIT

Fig.2

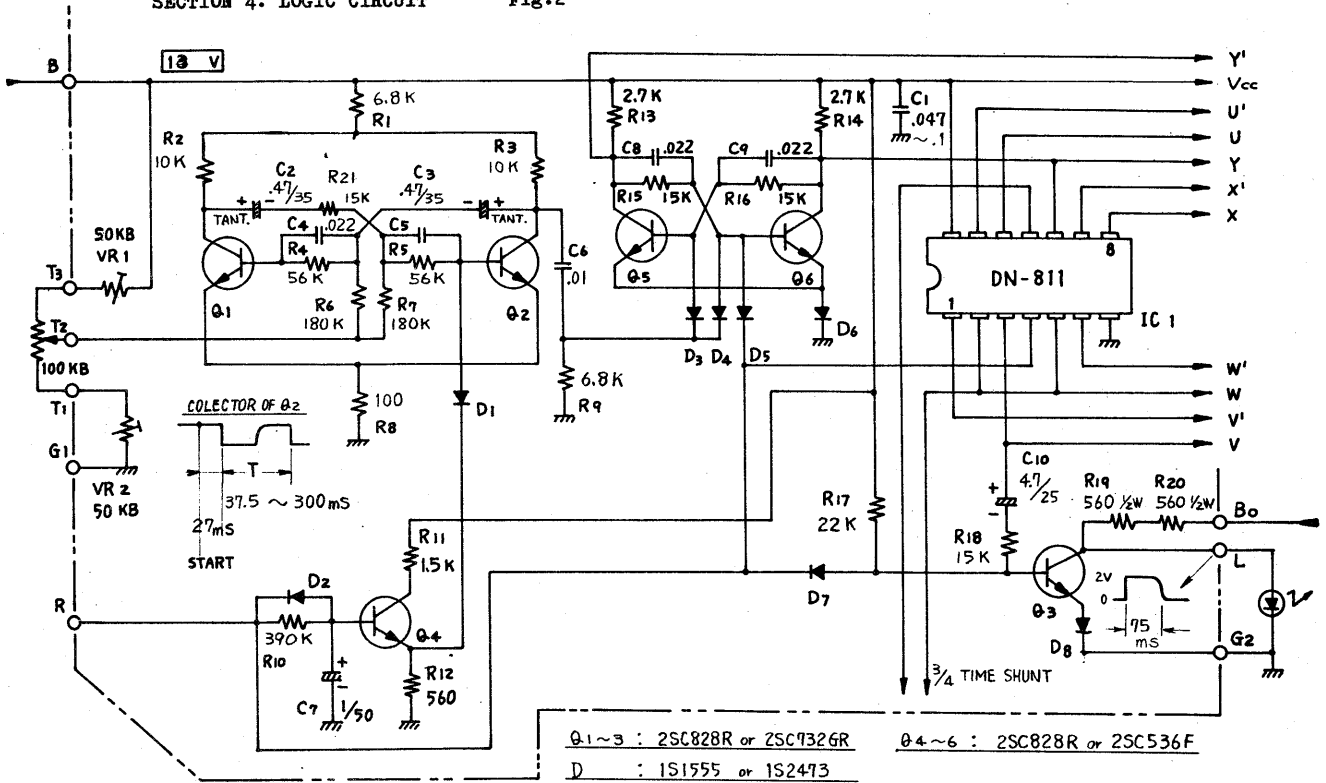

SECTION 5. MATRIX CIRCUIT

5-1. Circuit Diagram

Fig.3

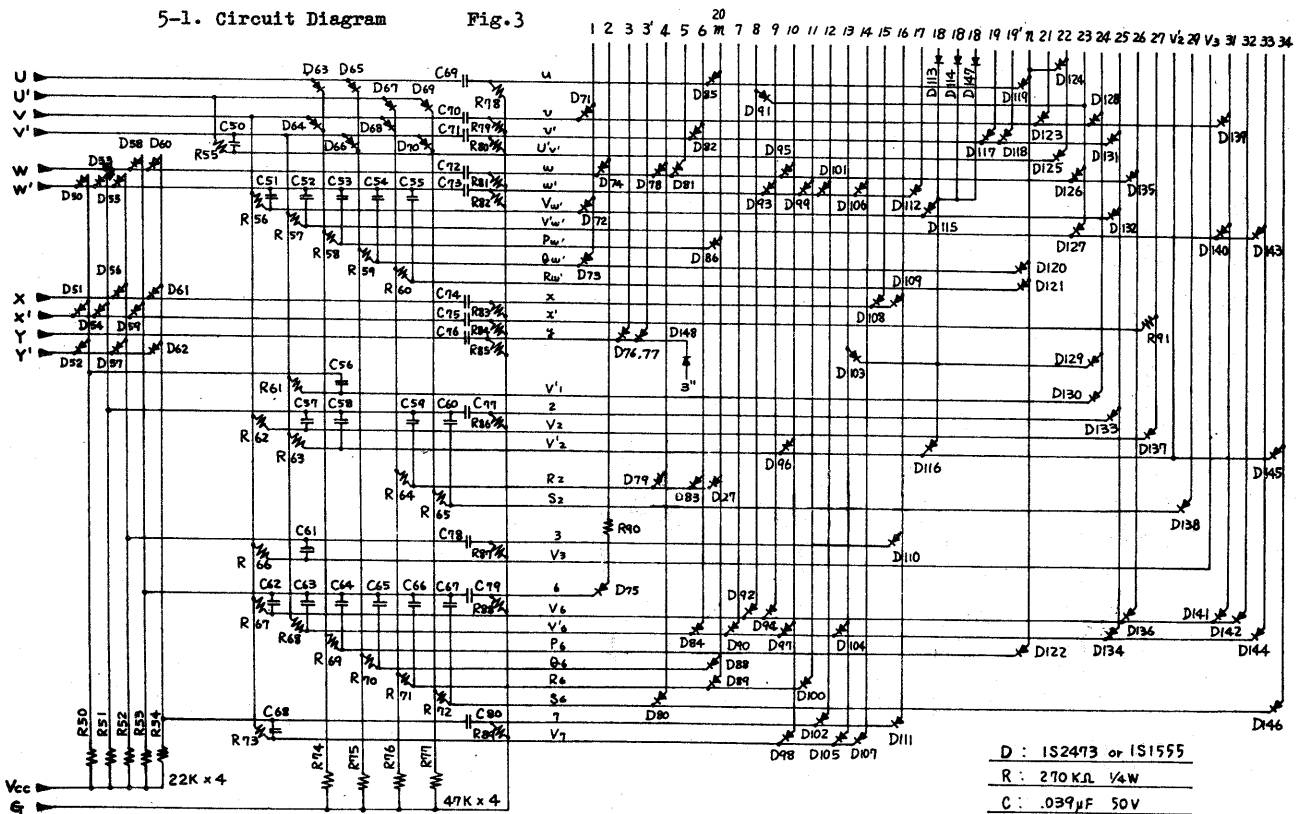

5-2. Logic Output Timing Chart

Fig.4

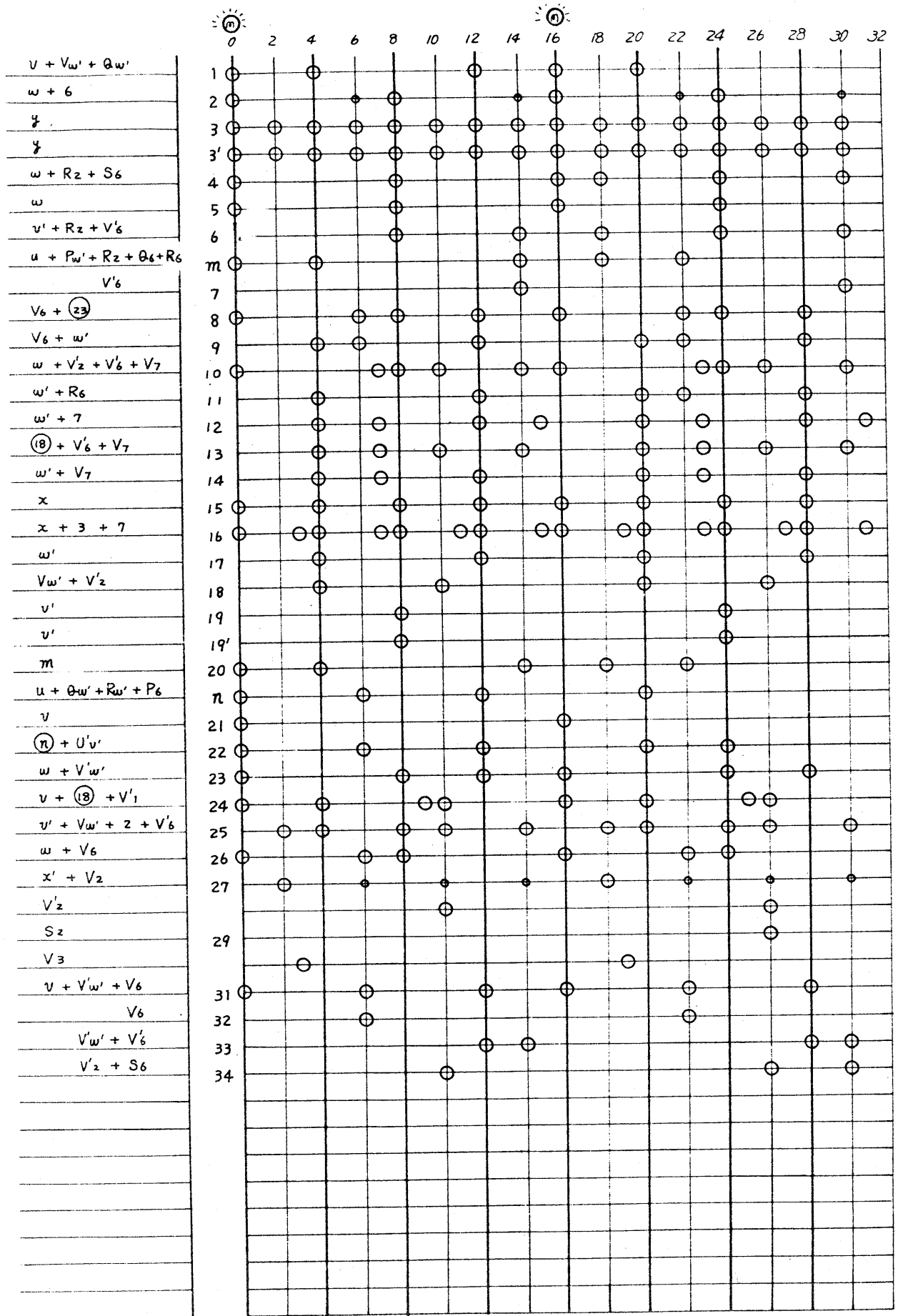

Fig.6

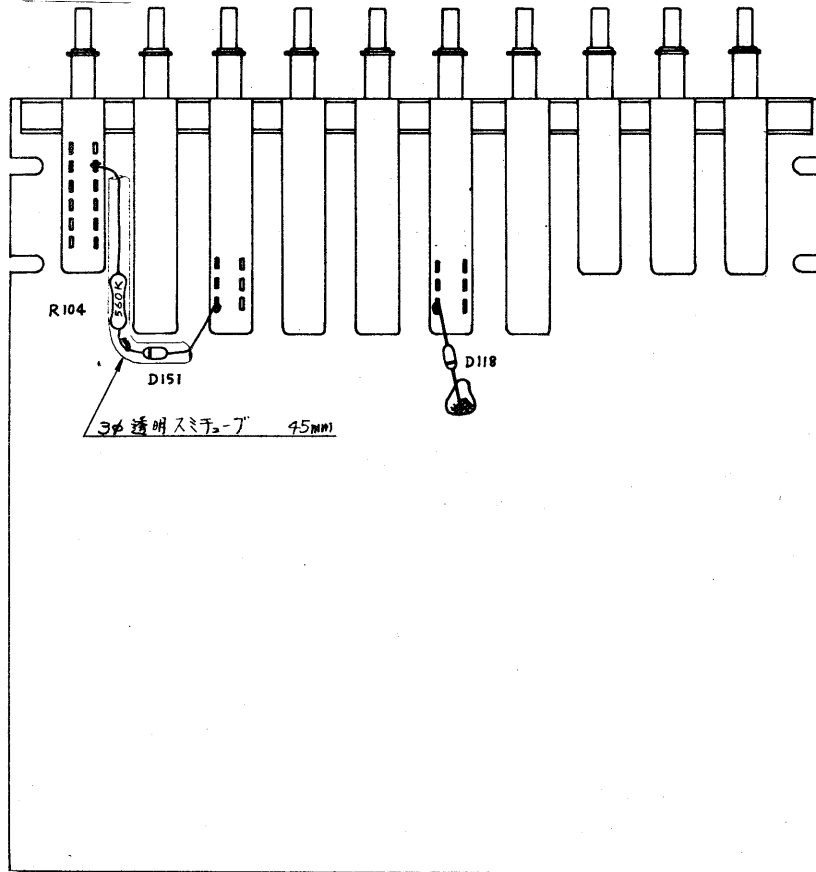
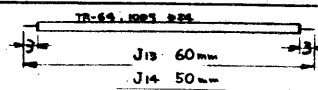
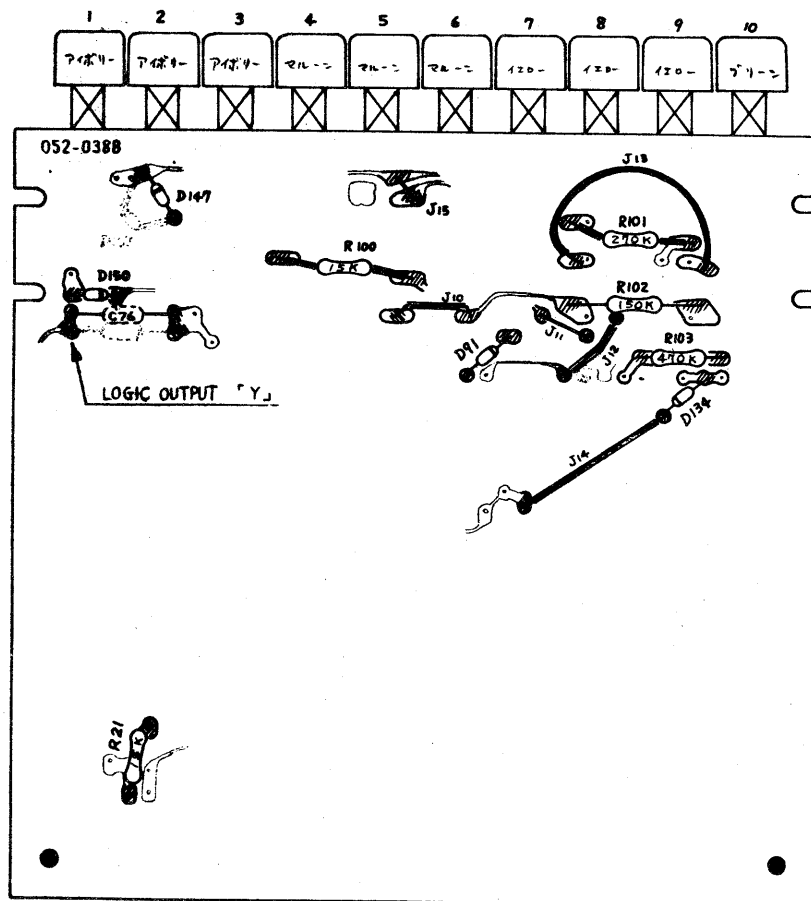
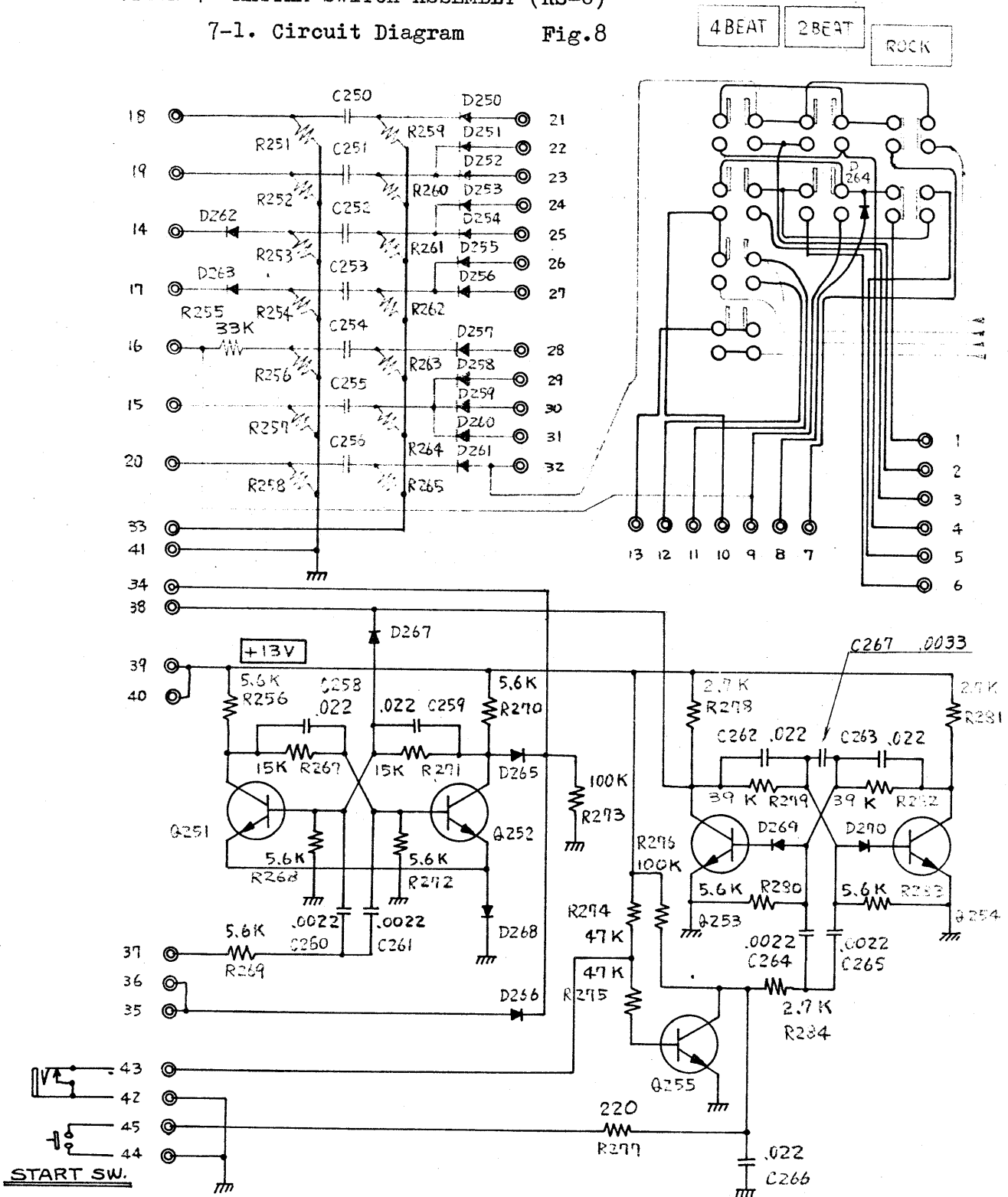

Fig.7



SECTION 7. RHYTHM SWITCH ASSEMBLY (RS-6)

7-1. Circuit Diagram Fig.8



- Q : 2SC536F or 2SC945P or 2SC828R
- D : 1S1555 or 1S2473
- R : 1MΩ 1/4W
- C : .022 μF 50V

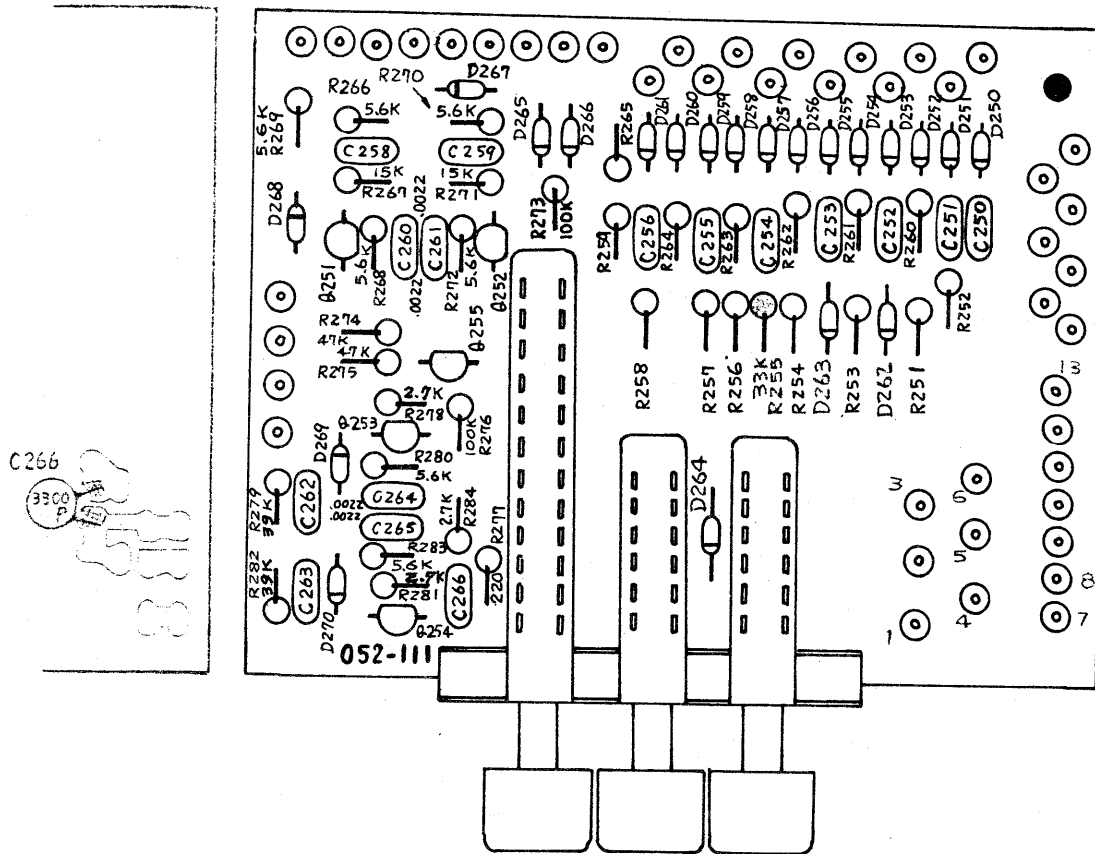

B	: 2SC536F or 2SC945P or 2SC828R
D	: 1S1555 or 1S2473
R	: 1M 1/4 W
C	: .022 μ 50V

SECTION 8. VOICE GENERATOR AND POWER SUPPLY CIRCUIT (VG-5)

8-1. Circuit Diagram Fig. 10

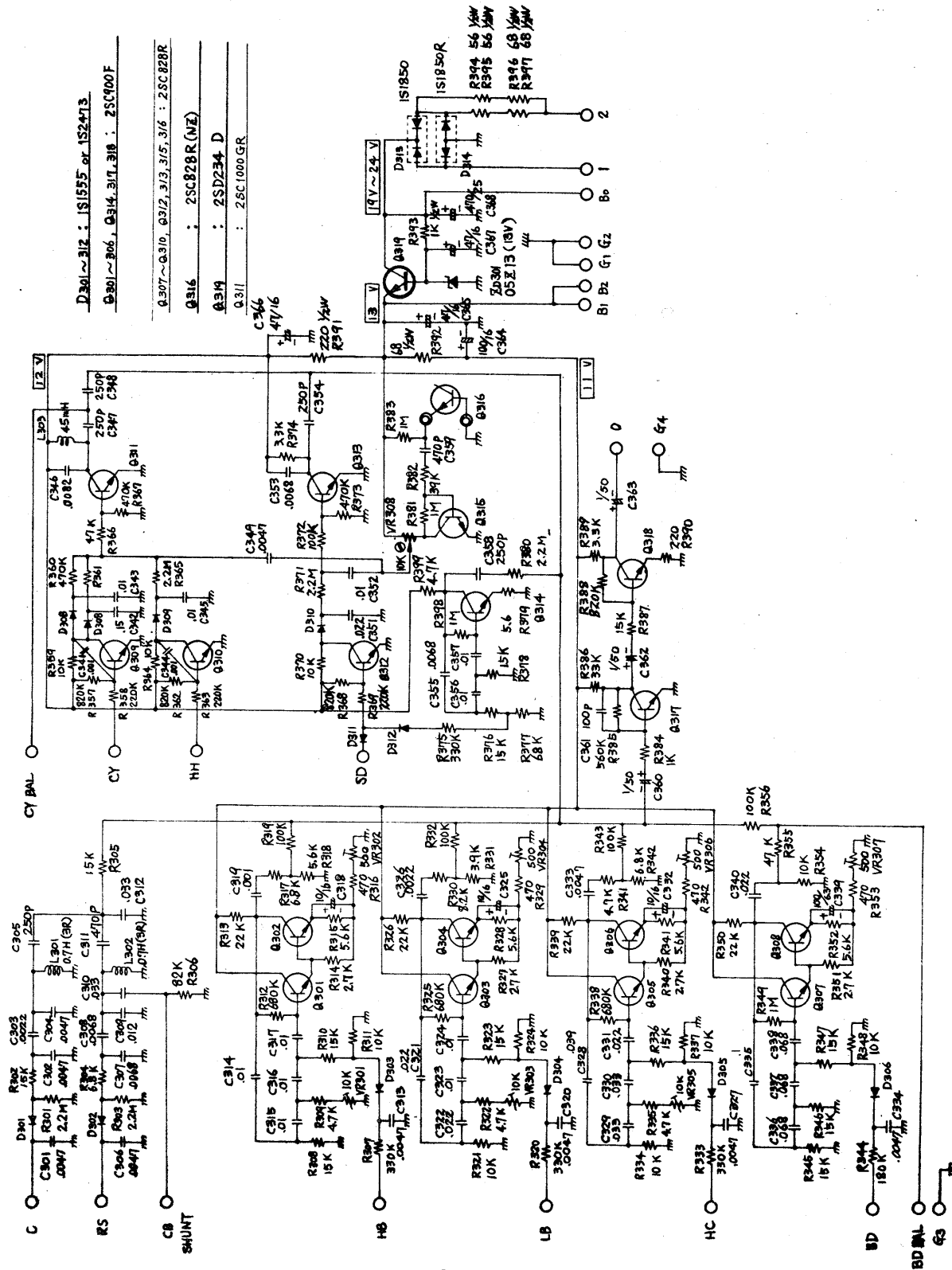

SECTION 9. RHYTHM ENSEMBLE PATTERN

Fig. 13

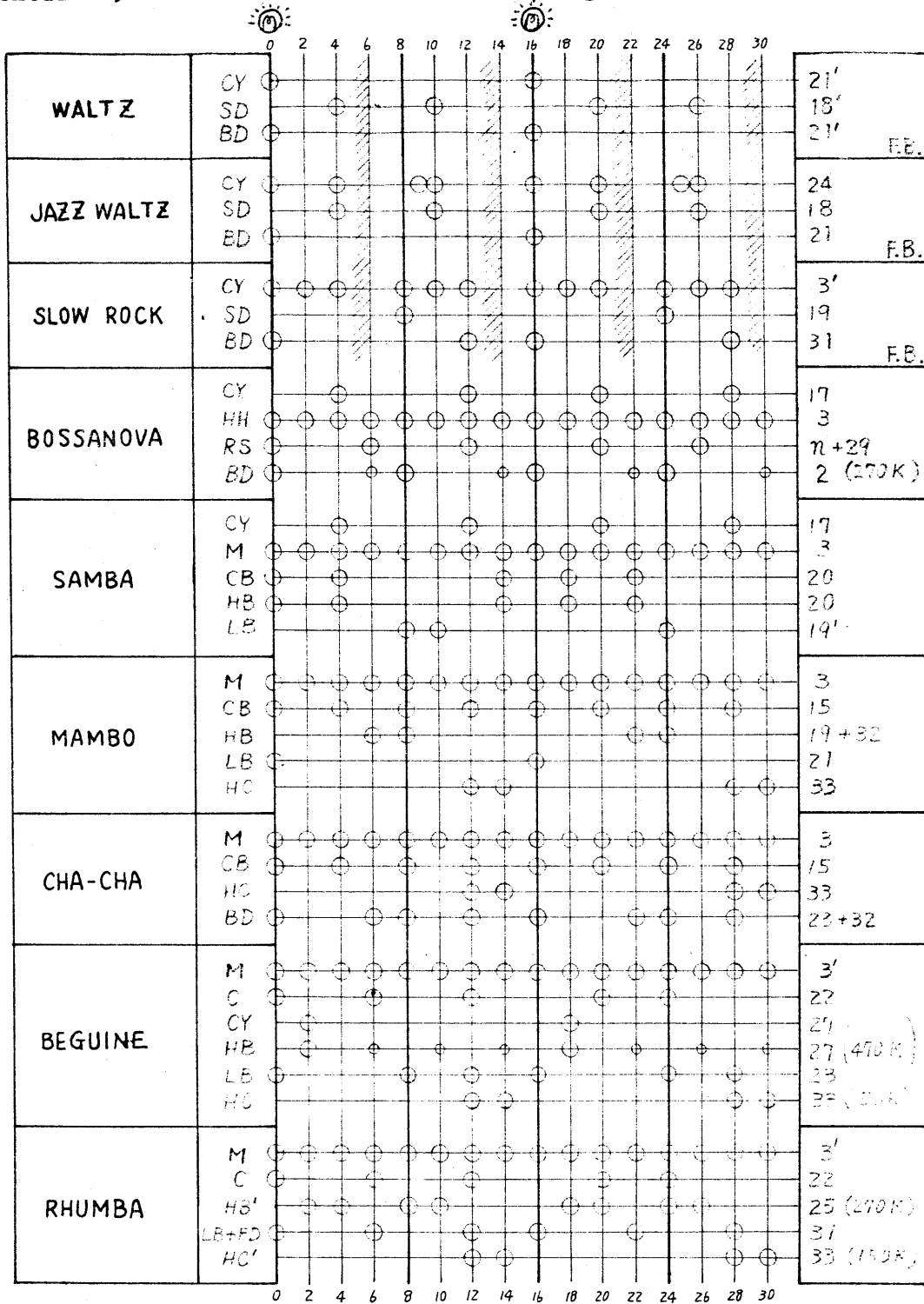

M = HH

Fig. 14

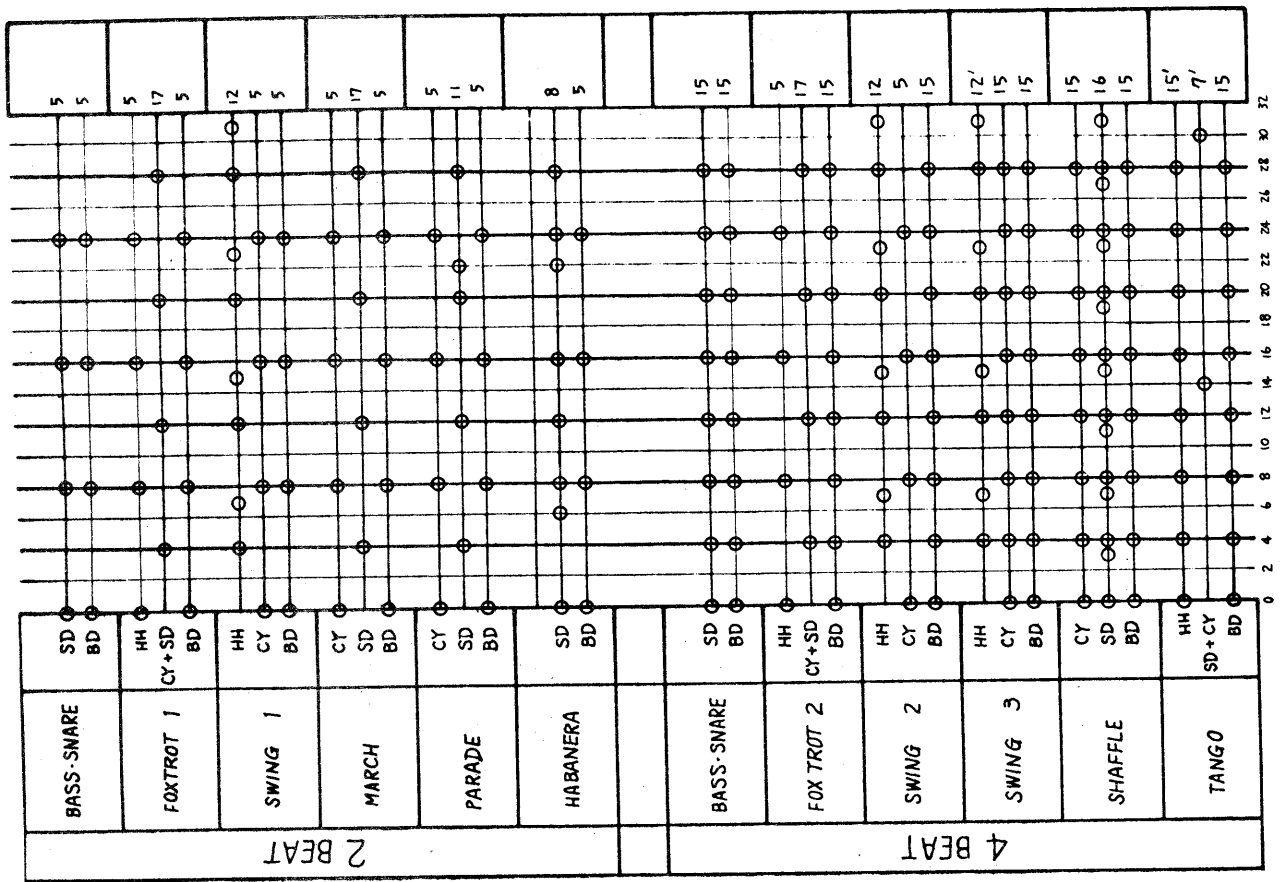

Fig. 15

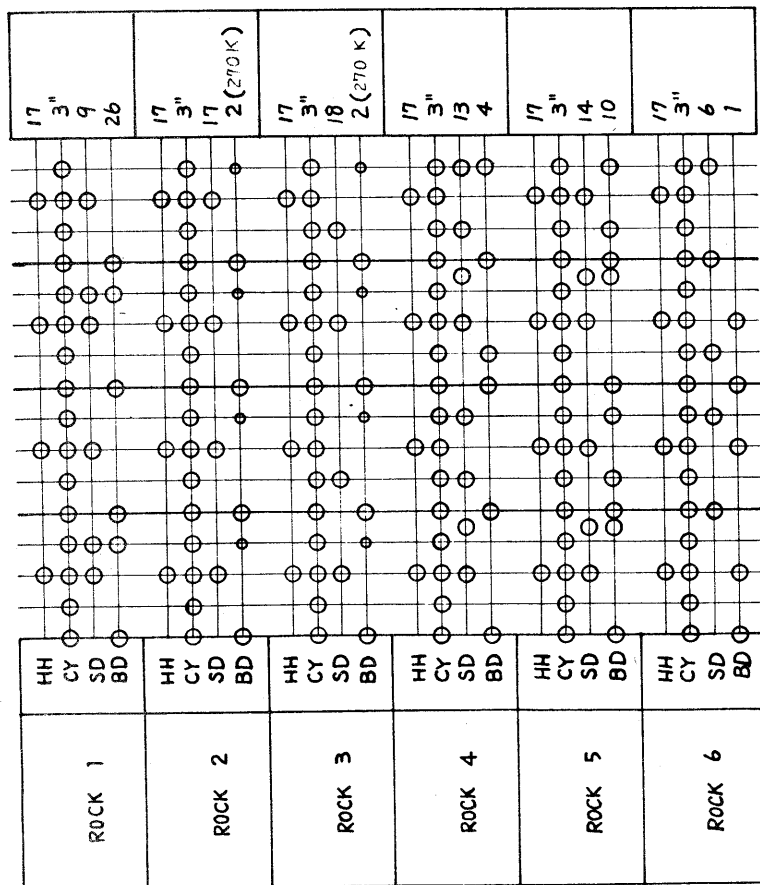
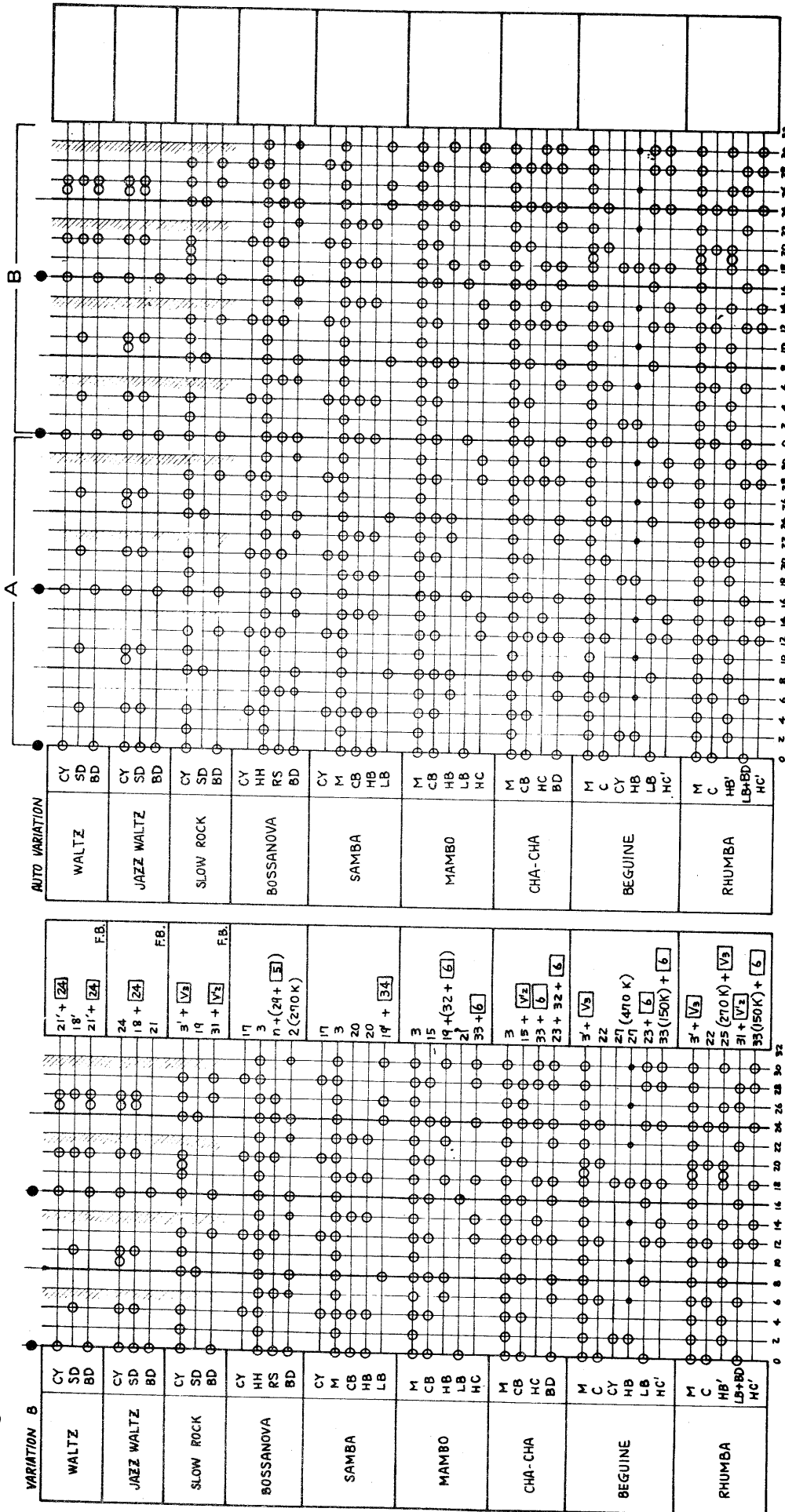

Fig. 16



M = HH

Fig. 17

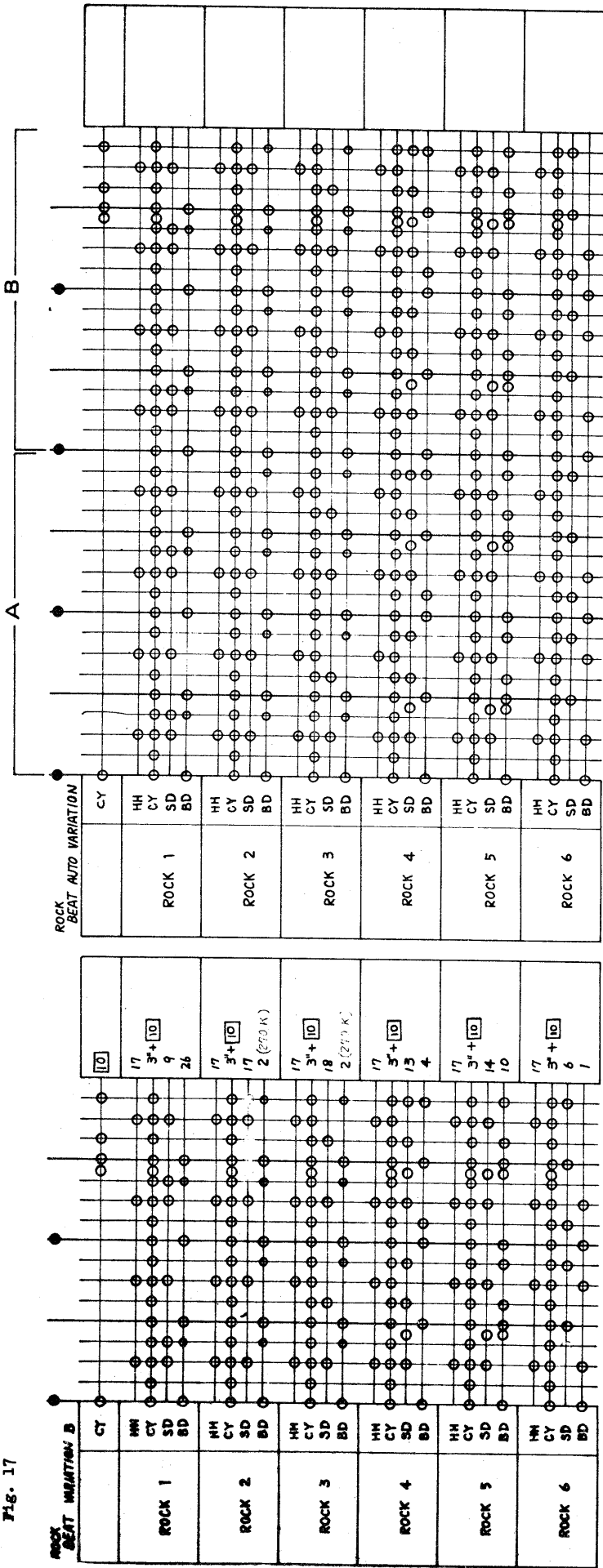
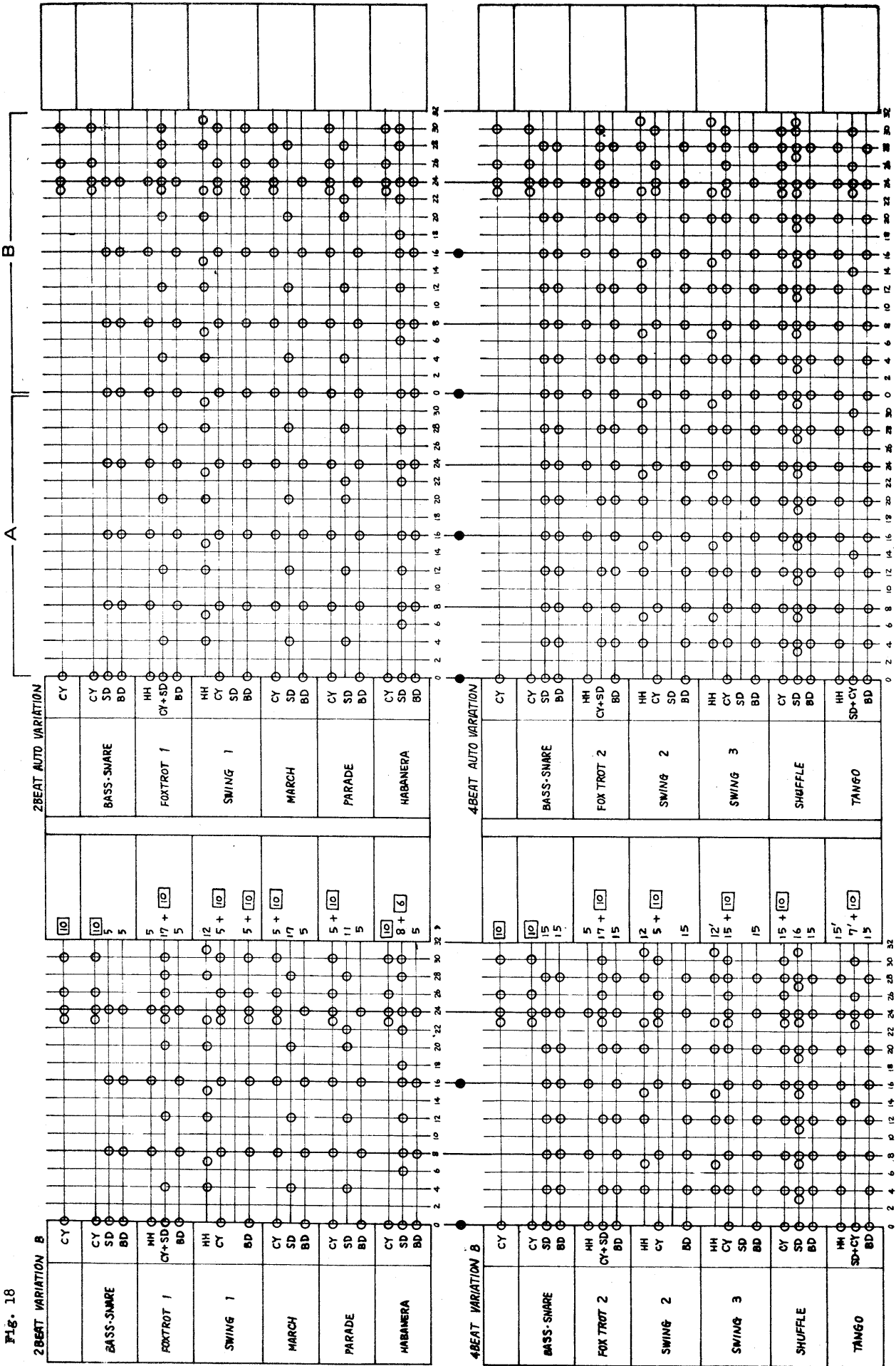

FIG. 18



SECTION 10. ADJUSTMENT

10-1. Logic Circuit

10-1-1. Adjustment of tempo speed by using oscilloscope

10-1-2. Rating

At oscillation period of Master Oscillator (Q1, Q2)

37.5mS (Quick) - 300mS (Slow)

10-1-3. Procedure

See the wave form on the collectors of Q6 on the first stage flip-flop (Q5 and Q6).

- Turn the Tempo control full clockwise (Quick), and adjust the trim-pot VR1 so that the period of one cycle of symmetric rectangular wave shows 75mS.
- Turn the Tempo control full counterclockwise (Slow), and adjust the trim-pot VR2 so that the period of one cycle of symmetric rectangular wave shows 600mS.
- Repeat abovementioned procedures a) and b) to get desired values.

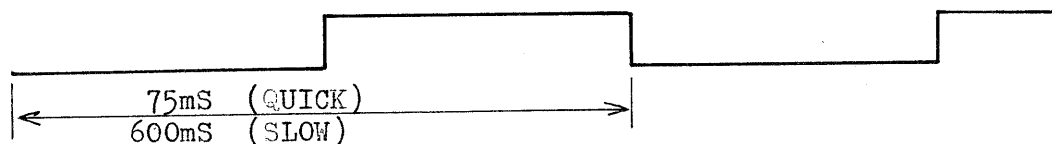

10-1-4. Wave form of the master oscillator (Q1 and Q2)

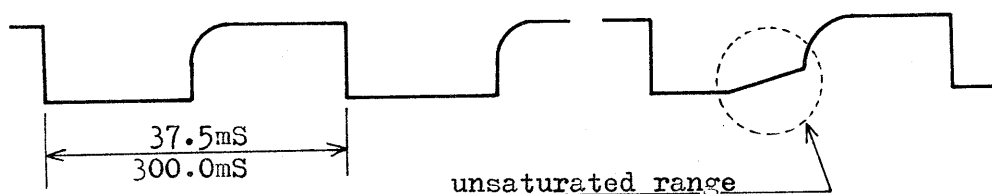

The period of master oscillator's output wave form is one-half of the period of the first stage flip-flop.

Be sure to confirm the wave form including no unsaturated range like the figure shown above right.

10-2. Tempo Lamp

See the wave form on the L terminal of Rhythm Switch Board Assembly RS-9 by the oscilloscope. And when the time value is otherwise, change the value of C10(4.7 μ /25V) or R18(15 K Ω).

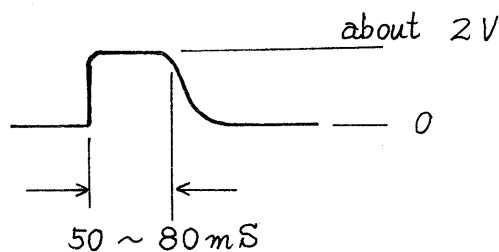

10-3. Voice Generator Circuit

STANDARD OUTPUT OF PERCUSSION INSTRUMENTS

	AMPLITUDE V			FREQUENCY mS Hz			DECAY TIME mS		
	MIN.	AVE.	MAX.	MIN.	AVE.	MAX.	MIN.	AVE.	MAX.
BD	1.6	2.1	2.7	18 (55.6)	16 (62.5)	14.3 (70)	65	100	140
HC	1.3	1.9	2.5	5.2 (192)	4.8 (208)	4.5 (222)	120	160	200
LB	0.6	1.0	1.5	2.6 (384)	2.5 (400)	2.25 (444)	20	40	60
HB	0.6	1.0	1.5	1.71 (571)	1.66 (600)	1.5 (666)	20	40	60
CB	1.5	2.0	2.5	1.3 (769)	1.2 (830)	1.12 (893)	20	35	50
RS	3.0	4.0	5.0	0.794 (1260)	0.676 (1480)	0.59 (1700)	3.5	5	7
C	1.0	1.5	2.0	0.5 (2000)	0.425 (2350)	0.4 (2500)	10	18	28
SD	-	-	-	-	-	-	-	-	-
	1.2	2.0	2.5	-	-	-	65	80	100
HH(M)	1.0	1.5	2.3	-	-	-	25	40	60
CY	1.2	2.0/0.5	2.5	-	-	-	350	400	600

10-3-1. Wave form on No.3 terminal of the main volume.

Provide the standard trigger pulse, output pulse on 5th terminal of the Rhythm Switch Board, for each input terminal of the voice generator. The period of the standard trigger pulse is generally 0.6sec. On actual adjustment, set the Tempo control on center position. In case that the amplifier is connected to the output jack (especially LOW), take down the main volume position of the Rhythm Arranger so that the input impedance of the amplifier connected don't affect the Voice Generator Circuit.

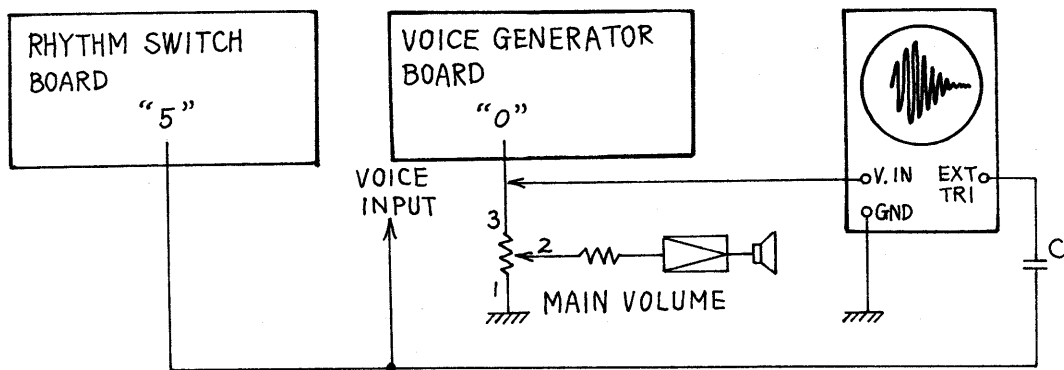

10-3-2. Adjustment of Drum section (BD, HC, LB, HB, CB, RS, C)

10-3-2-1. Adjustment of the Bass Drum

Connect a trigger pulse to the terminal "BD" on PCB, and adjust the trim-pot VR307 so as to get the decay time as 90mS. And confirm that output voltage and frequency are within regular value.

When the frequency of BD is over or under the regular value, check the circuit constant, and change the capacitors C336-C338 and the resistors R345 R346. In case that capacitors or resistors or both are changed, repeat abovementioned adjustment.

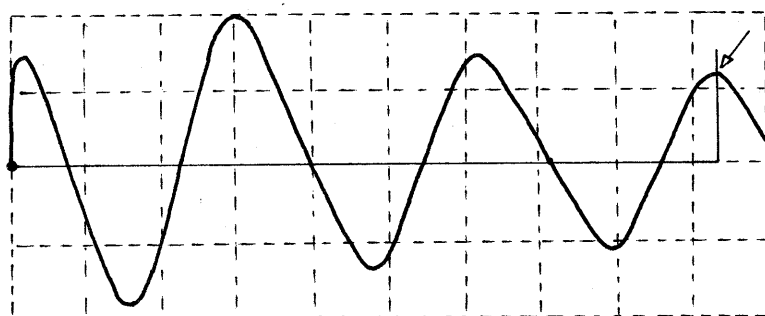

5 mS/div
1 V/div

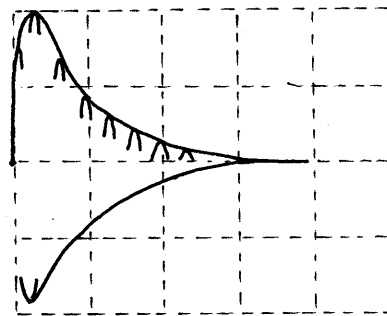

50 mS/div
1 V/div

10-3-2-2. Adjustment of the High Conga

Connect a trigger pulse to the terminal "HC" on PCB.

a) Adjustment of frequency

Adjust the trim-pot VR305 so as to make the frequency as 208Hz (4.8mS).

b) Adjustment of Decay time

Adjust the trim-pot VR306 so as to get the Decay time as 160mS.

Repeat abovementioned adjustment.

c) Adjustment of the output voltage

Check the output voltage within regular value.

When the output voltage of HC is over or under the regular value,

check the circuit constant, and change the resistors R341-R342. In case that capacitors or resistors or both are changed, repeat abovementioned adjustment.

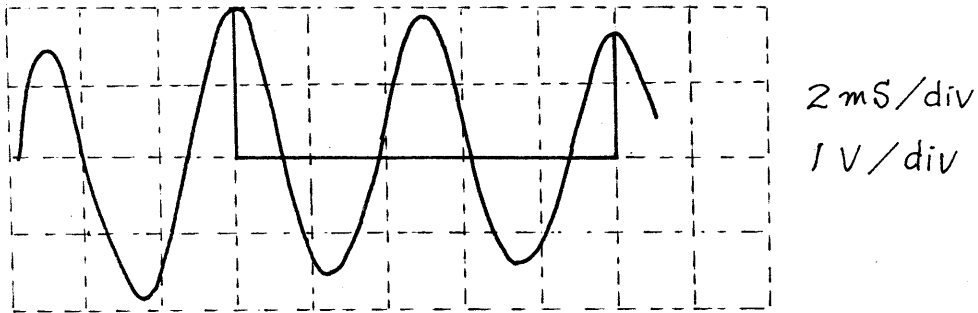

10-3-2-3. Adjustment of the Low Bongo

Connect a trigger pulse to the terminal "LB" on PCB.

a) Adjustment of frequency

Adjust the trim-pot VR303 so as to make the frequency as 400Hz (2.5mS).

b) Adjustment of Decay time

Adjust the trim-pot VR304 so as to get the Decay time as 40mS.

Repeat abovementioned adjustment.

c) Adjustment of the output voltage

Check the output voltage within regular value.

When the output voltage of LB is over or under the regular value, check the circuit constant, and change the resistors R330-R331.

In case that capacitors or resistors or both are changed, repeat abovementioned adjustment.

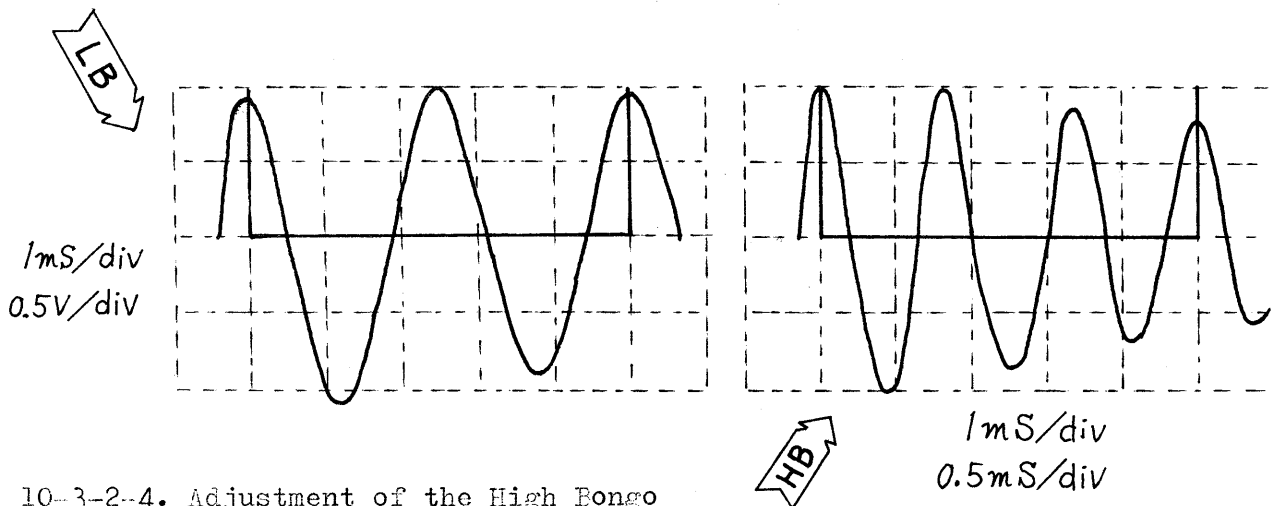

10-3-2-4. Adjustment of the High Bongo

Connect a trigger pulse to the terminal "HB" on PCB.

a) Adjustment of frequency

Adjust the trim-pot VR301 so as to make the frequency as 600Hz (1.66mS).

b) Adjustment of Decay time

Adjust the trim-pot VR302 so as to get the Decay time as 40mS.
Repeat abovementioned adjustment.

c) Adjustment of the output voltage

Check the output voltage within regular value.

When the output voltage of HB is over or under the regular value,
check the circuit constant, and change the resistors R317-R318.

In case, that capacitors or resistors or both are changed, repeat
abovementioned adjustment.

10-3-2-5. Adjustment of the Cow Bell and the Rim Shot

Connect a trigger pulse to the terminal "RS" on PCB.

Ground the terminal "CB SHUNT" to get CB voice, and open the
terminal for RS voice.

Check the output voltage, the frequency and the decay time within
regular value.

Change the output voltage by changing circuit constant (R304, C307,
C308 and C311).

Change the frequency by changing circuit constant (C309 and C310).

In case that circuit constant was changed, check the output
voltage, the frequency and the decay time within regular value.

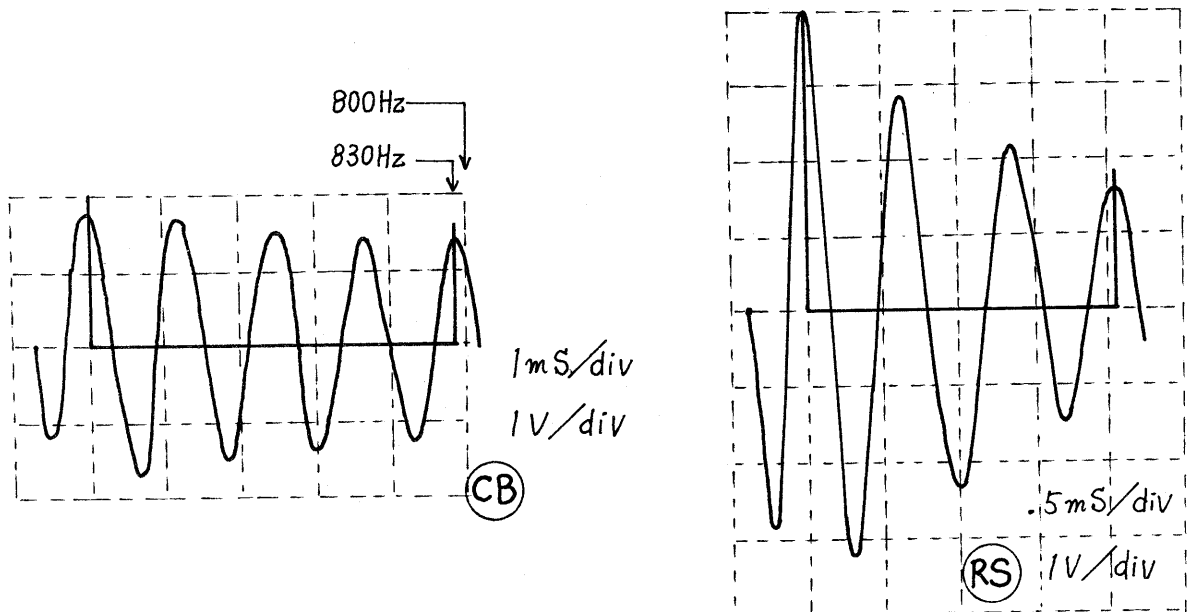

10-3-2-6. Adjustment of the Claves

Connect a trigger pulse to the terminal "C" on PCB.

This circuit is adjustless like the CB's or the RS's.

Check the output voltage, the frequency and the decay time within
regular value.

Change the output voltage by changing circuit constant (R302, C302, C303 and C305).

Change the frequency by changing circuit constant (C304).

In case that circuit constant was changed, check the output voltage, the frequency and the decay time within regular value.

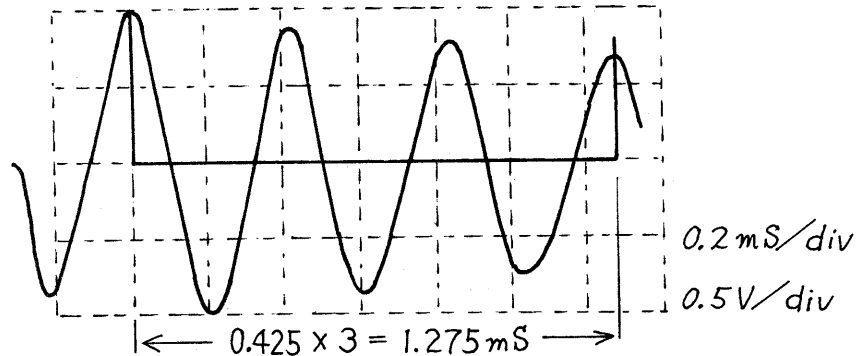

10-3-3. Adjustment of noise section (HH, CY and SD)

10-3-3-1. Adjustment of the High-Hat

Connect a trigger pulse to the terminal "HH" on PCB.

Adjust the trim-pot VR308 so as to get the output voltage as 1.5V

And check the decay time within regular value.

10-3-3-2. Adjustment of the Cymbal

Connect a trigger pulse to the terminal "CY" on PCB.

Check the output voltage within regular value.

Adjustor of the output voltage is the same trim-pot VR308 that for the High-Hat.

And check the decay time within regular value.

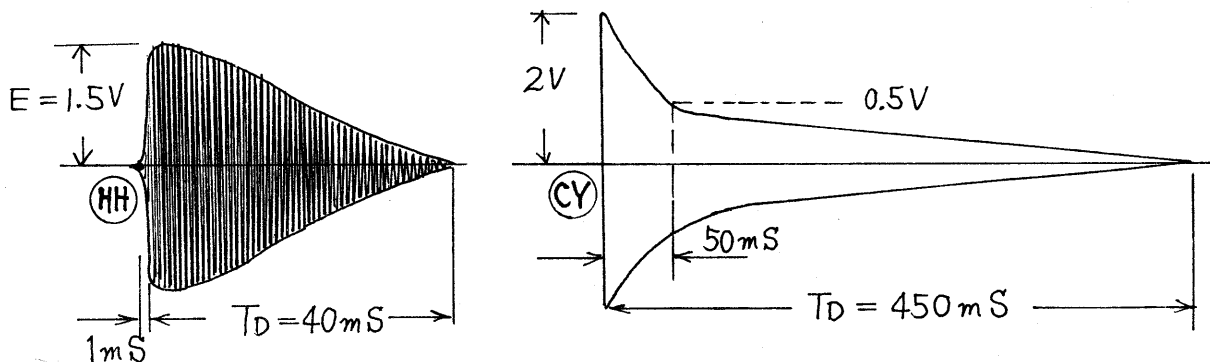

10-3-3-3. Adjustment of the Snare Drum

Connect a trigger pulse to the terminal "SD" on PCB.

Check the output voltage and the decay time within regular value.

Adjustor of the output voltage is the same trim-pot VR308 that for the High-Hat and the Cymbal.

The Snare Drum includes the weak sound of Low Bongo.

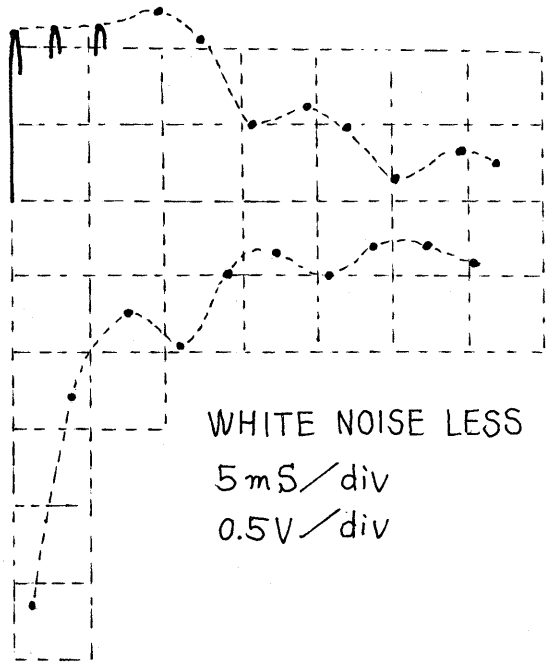
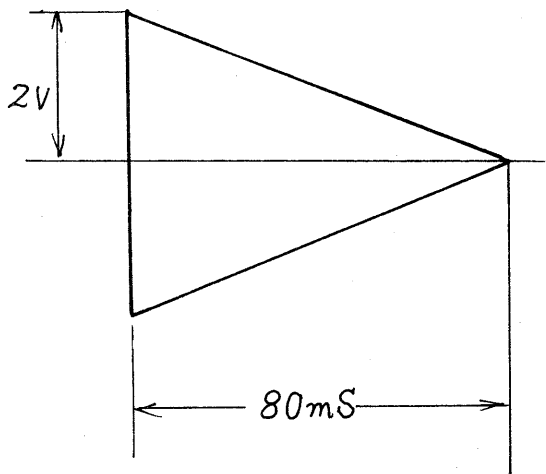

SECTION 11. PARTS LIST

MODEL TR-66 PARTS LIST

CABINET

CHASSIS ASSEMBLY

Chassis	No.27	(Main Chassis)
"	No.28	(Rhythm Switch Chassis)
"	No.29	(Rear Side : Black)
Holder		(Lever Switch)
Knob	TK-1112	(
"	TK-1114	
Rotary Switch	ESR-E366K25	
Lever Switch	ESL-2412	
Keyboard Switch	S-J6471-01	
Key Top	S-J6292 A2	
Push Button Switch	10F0-0004DC2020	
"	3F0-0001DC2020	
Potentiometer	10K(B)S	EVC-BO5K15 (Volume)
"	50K(B)	EVC-BOAK15 (Balance)
"	100K(B)	EVC-BOAK25 (Tempo)
Power Transformer	PT-50A-C	(0-100-120V)
"	or PT-50A-D	(0-230-250V)
Jack	SG-7615	No.5
Fuse	0.25A	SGA0.250
Fuse Holder	TF-758	
Terminal Strip	2L6P	
Cord Bushing	R-5	
Long Nut	No.7	(52mm)
P.C.B. Holder	LCBS-4N	
Light Emitting Diode		LD-64R
"	Terminal Strip	L-3522-1P
Panel	No.40	

RHYTHM SWITCH ASSEMBLY RS-9 (MAIN)

" RS-6

VOICE GENERATOR BOARD ASSEMBLY VG-5

SEMICONDUCTORS

IC

Silicon Transistor	2SC828R
"	2SC828R (White Noise)
"	2SC536F or 2SC828R
"	2SC732GR or 2SC828R
"	2SC900F or 2SC1000GR
Silicon Diode	1S2473 or 1S1555
"	1S1850 (Rectifier)
"	1S1850 (")
Voltage Regulator Diode	05Z13

COILS

Coil	0.7H	3R
Chock Coil	45mH	

RESISTORS

Trim-pot Resistor	500 ohm	EVL-R4X
"	10K ohm	"
"	50K ohm	"
Carbon Film Resistor	56 ohm	1/4 R
"	100ohm	"

MODEL TR-66 PARTS LIST

Carbon Film Resistor	220ohm	1/4 R
"	470ohm	"
"	560ohm	"
"	1 Kohm	"
"	1.5Kohm	"
"	2.7Kohm	"
"	3.3Kohm	"
"	3.9Kohm	"
"	4.7Kohm	"
"	5.0Kohm	"
"	6.8Kohm	"
"	8.2Kohm	"
"	10 Kohm	"
"	15 Kohm	"
"	22 Kohm	"
"	33 Kohm	"
"	39 Kohm	"
"	47 Kohm	"
"	56 Kohm	"
"	68 Kohm	"
"	82 Kohm	"
"	100Kohm	"
"	150Kohm	"
"	180Kohm	"
"	220Kohm	"
"	270Kohm	"
"	330Kohm	"
"	390Kohm	"
"	470Kohm	"
"	560Kohm	"
"	680Kohm	"
"	820Kohm	"
"	1 Mohm	"
Carbon Solid Resistor	56 ohm	ERC12GK
"	68 ohm	"
"	220 ohm	"
"	560 ohm	"
"	1 Kohm	"
"	2.2Mohm	"
"	6.8Mohm	"

CAPACITORS

Ceramic Capacitor	100 pfd	50V
"	250 pfd	"
"	470 pfd	"
Ceramic or Plastic Film Capacitor	1000pfd	50V
"	2200pfd	"
"	3300pfd	"
Plastic Film Capacitor	.0047mfd	50V
"	.0068mfd	50V
"	.0082mfd	"
"	.01 mfd	"
"	.012 mfd	"
"	.022 mfd	"
"	.033 mfd	"
"	.039 mfd	"

MODEL TR-66 PARTS LIST

Plastic Film Capacitor	.047mfd	50V
"	.068mfd	"
"	.1 mfd	"
"	.15 mfd	"
Electrolytic Capacitor	1 mfd	50V
"	4.7 mfd	25V
"	10 mfd	16V
"	47 mfd	16V
"	100 mfd	6.3V
"	100 mfd	16V
"	470 mfd	25V
Tantalum Capacitor	.47 mfd	35V K