

# Introduction

Gotein,the 5 may 2006

Hello,

My name is Thierry EPPHERRE ,I am French and 35 years old.I am an electronician,my job is repairing TVs,VCRs but also wasching machines,fridges....in a small shop where I work since 1994.

My hobbies are ,since I was 11 years old,electronic (but electronic in audio applications!),music (I am a very bad drummer...),and recording.

The first time I saw a drummer in 1985,it was the SEVEN orchestra in my little village.The drummer was playing a SIMMONS SDS8 with an acoustic snare and acoustic cymbals.For me it was a revelation!But I was 14 years old and I couldn't buy this!

At this time I began to be interested by drum synthesis.I tried some schematics of drum boxes from analog organs with damped oscillators and noise generators.

In 1985 I realised a circuit described in the ELEKTOR magazine, the disco drum module based around a XR2206 oscillator chip.

I was always fascinated by SIMMONS drums (the SEVEN drummer was now playing a SDS9 kit!) and so,in1988 I ordered docs and schematics of SDS8,SDS800,SDS5 at MUSICLAND,the French SIMMONS importator.But SDS8 and SDS5 schematics where unreadable (I could just have an idea of the circuits).The SDS800 were better (you can find them on internet now) but were based on CEM3394 chips.So I ordered at MUSICLAND a CEM3394 and I made a Tom voice.

In 1996,I bought a second hand SDS9 with pads and first I opened it to see how it was built!! I started to draw Tom voices (CEM3394...like SDS800series...) and Snare and Rim voices.

Here is the list of the drum modules I own now:

- \*ALESIS D4 (the only one that's not second hand!)
- \*SIMMONS SDS9
- \*SIMMONS MTX9
- \*SIMMONS SDS1000
- \*SIMMONS SDS5
- \*PEARL DRX1 (very good and interesting analog drum module!)
- \*PEARL SC20
- \*DYNACORD P20
- \*DYNACORD ADDTWO (not fonctionning!)
- \*DDRUM PLUS
- \*DDRUM2 (it was not fonctionning but I have repaired it!)
- \*TAMA TECHSTAR TS 305
- \*TR707 ROLAND

Two years ago ,in 2004,I ordered the SDS9 owner manual and schematics at the Manual Manor,but there was only the schematics of the power supply and a general description of the circuits.So I started to draw the complete schematic of the SDS9.I can say that it's a very very big work!

I have finished it and I am happy to send it to this superbe site.

Now I have a lot of old drummodules and I am drawing the SDS5 schematic .I have noticed some errors on SIMMONS original ones!

I hope that people will be interested and that we will be able to exchange schematics,mods,ideas...

I will certainly update these documents with comments on circuits,binaries of sound roms....

See you soon,

Thierry EPPHERRE,a French SIMMONS fan

# SIMMONS SDS 9 POWER SUPPLY & PHONES

drawn by Thierry EPPHERRE 08 2004

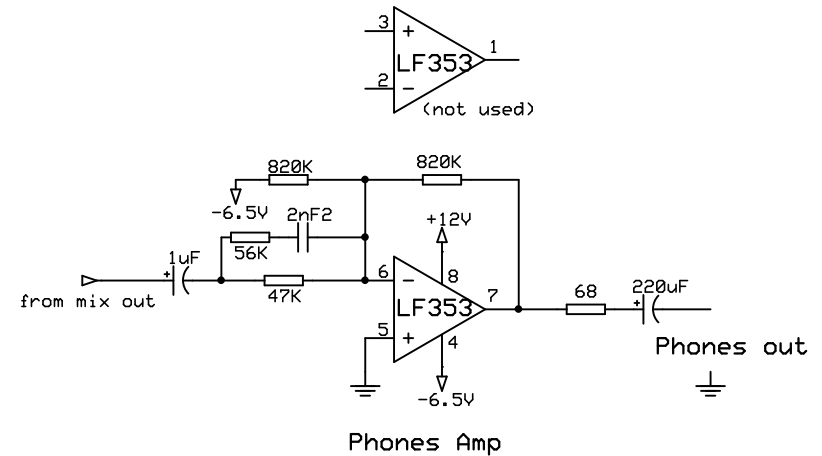
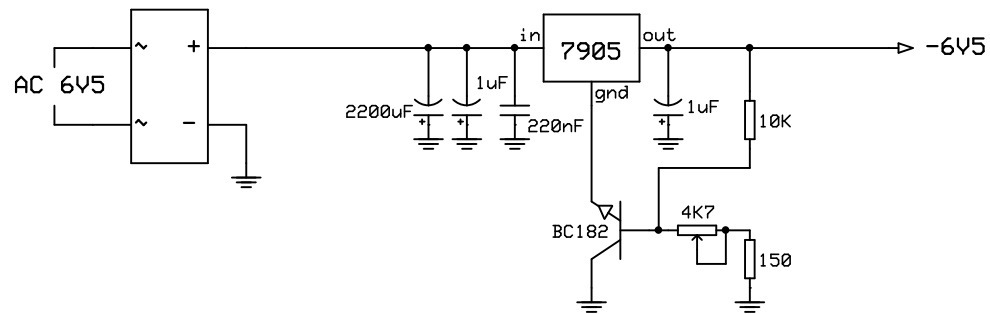
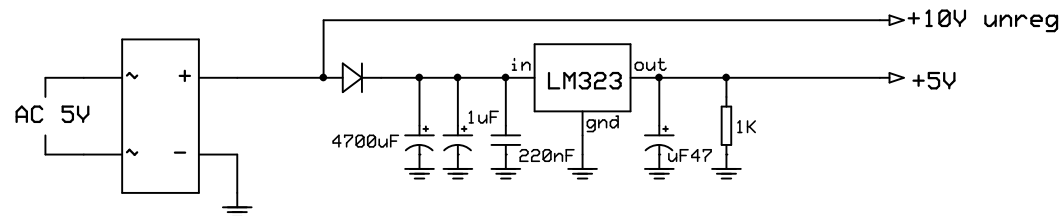
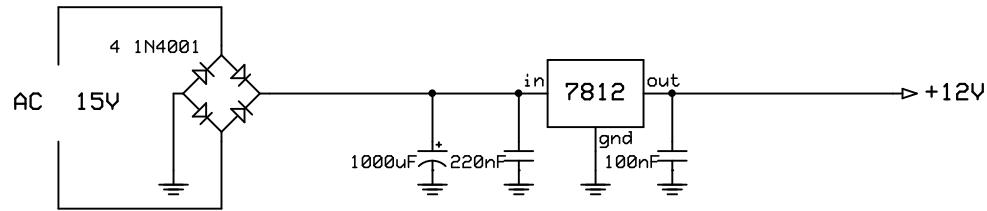

# SIMMONS SDS 9 COMPUTER

drawn by Thierry EPPHERRE 08 2004

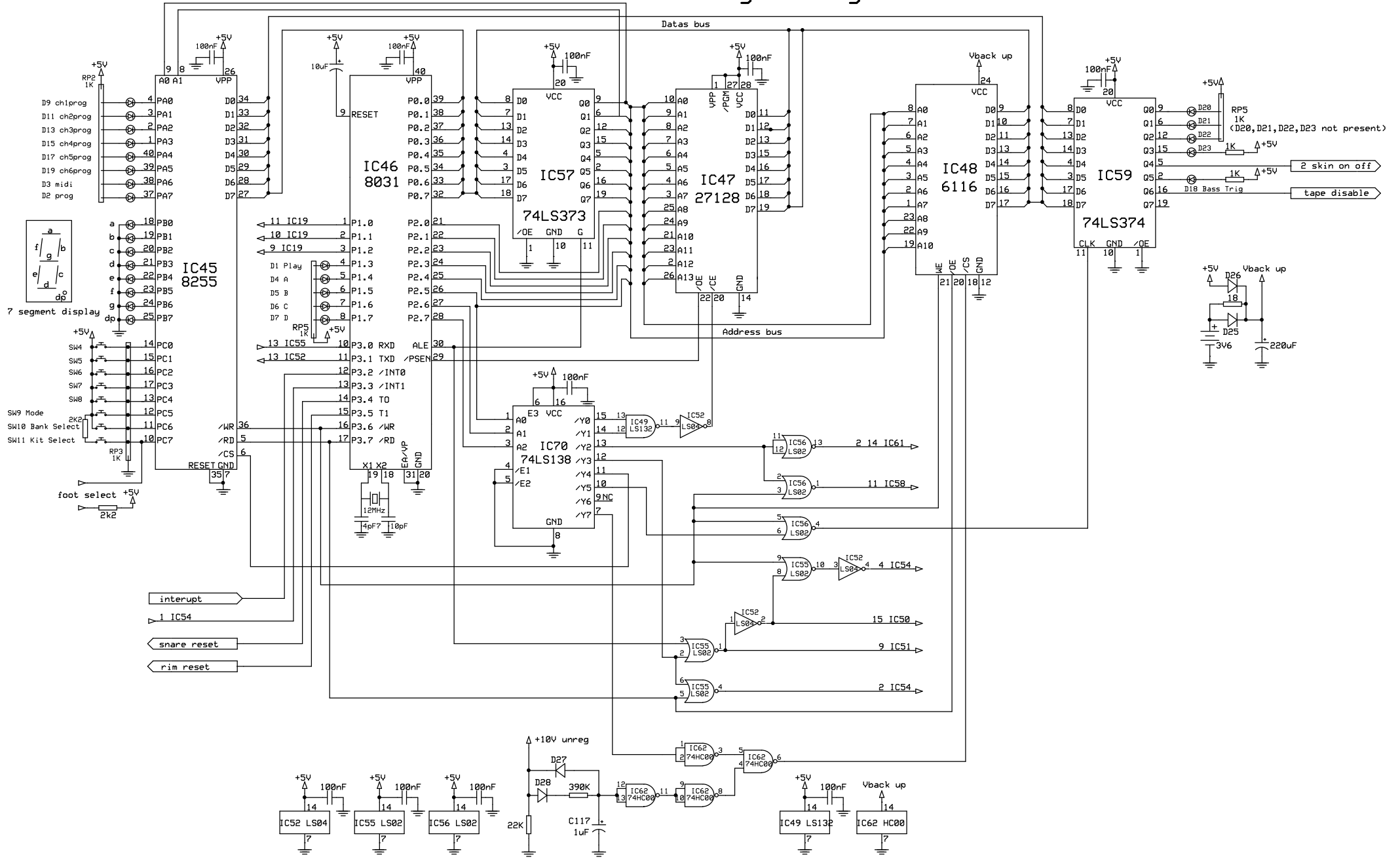

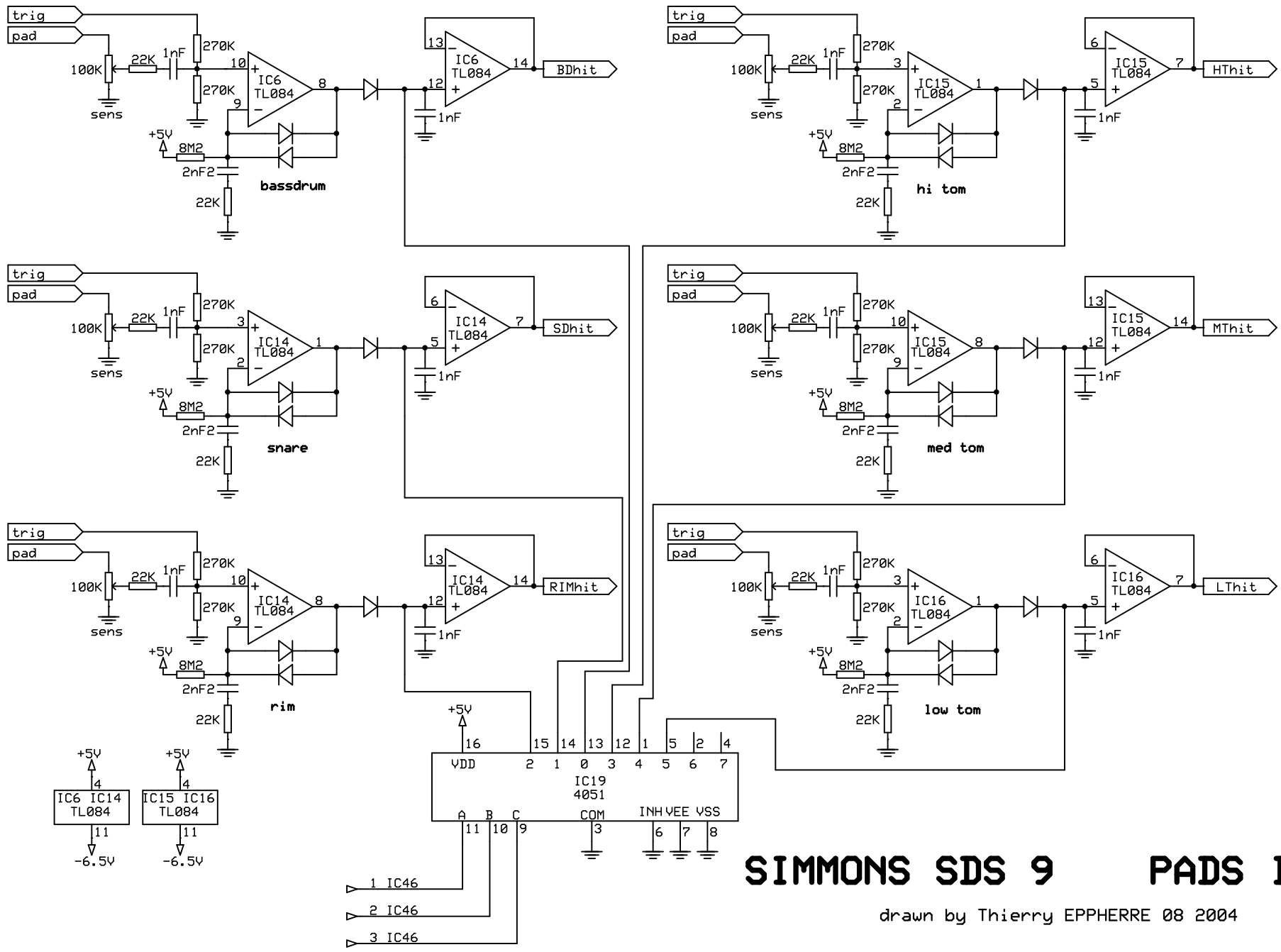

# SIMMONS SDS 9 PADS INPUT

drawn by Thierry EPPHERRE 08 2004

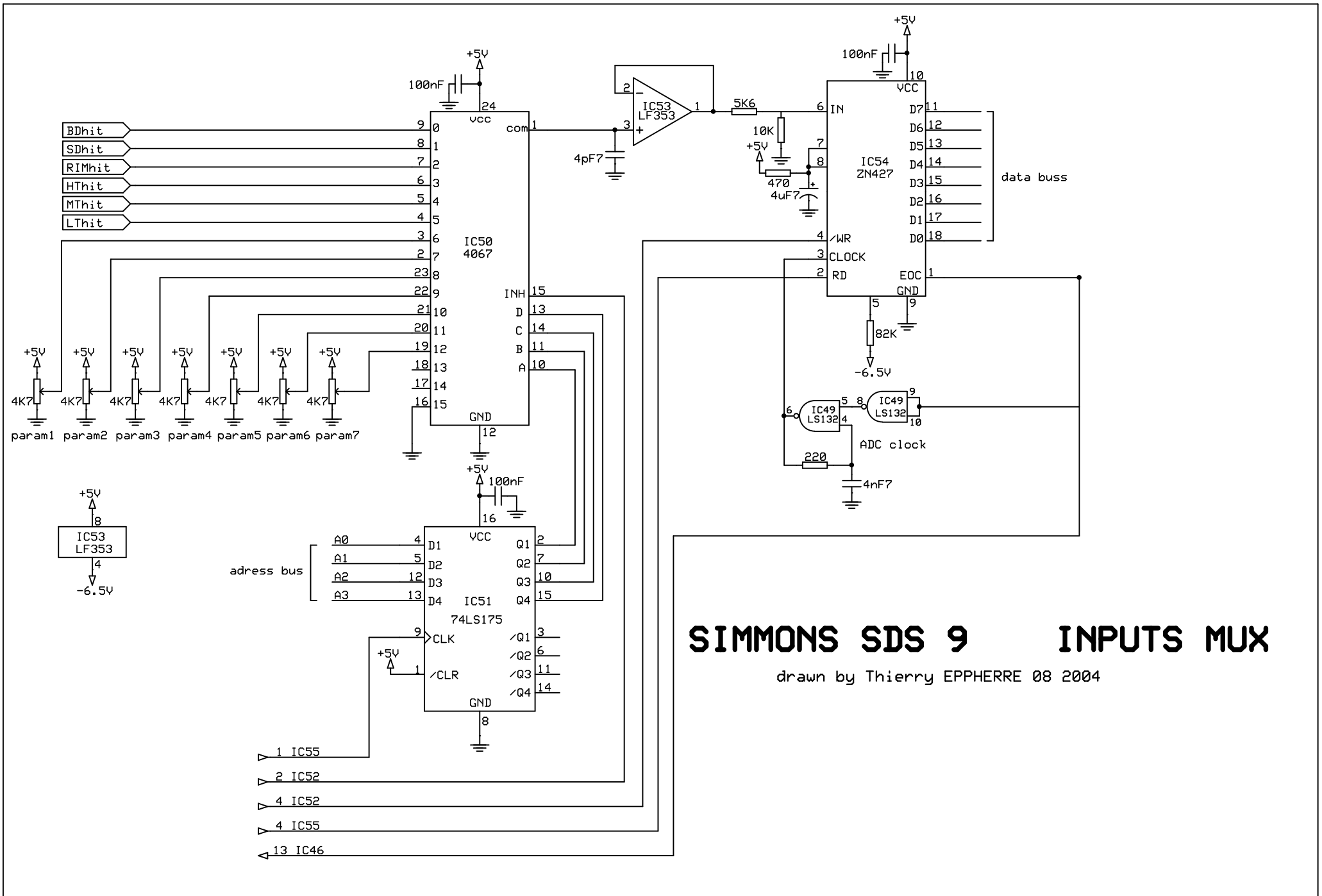

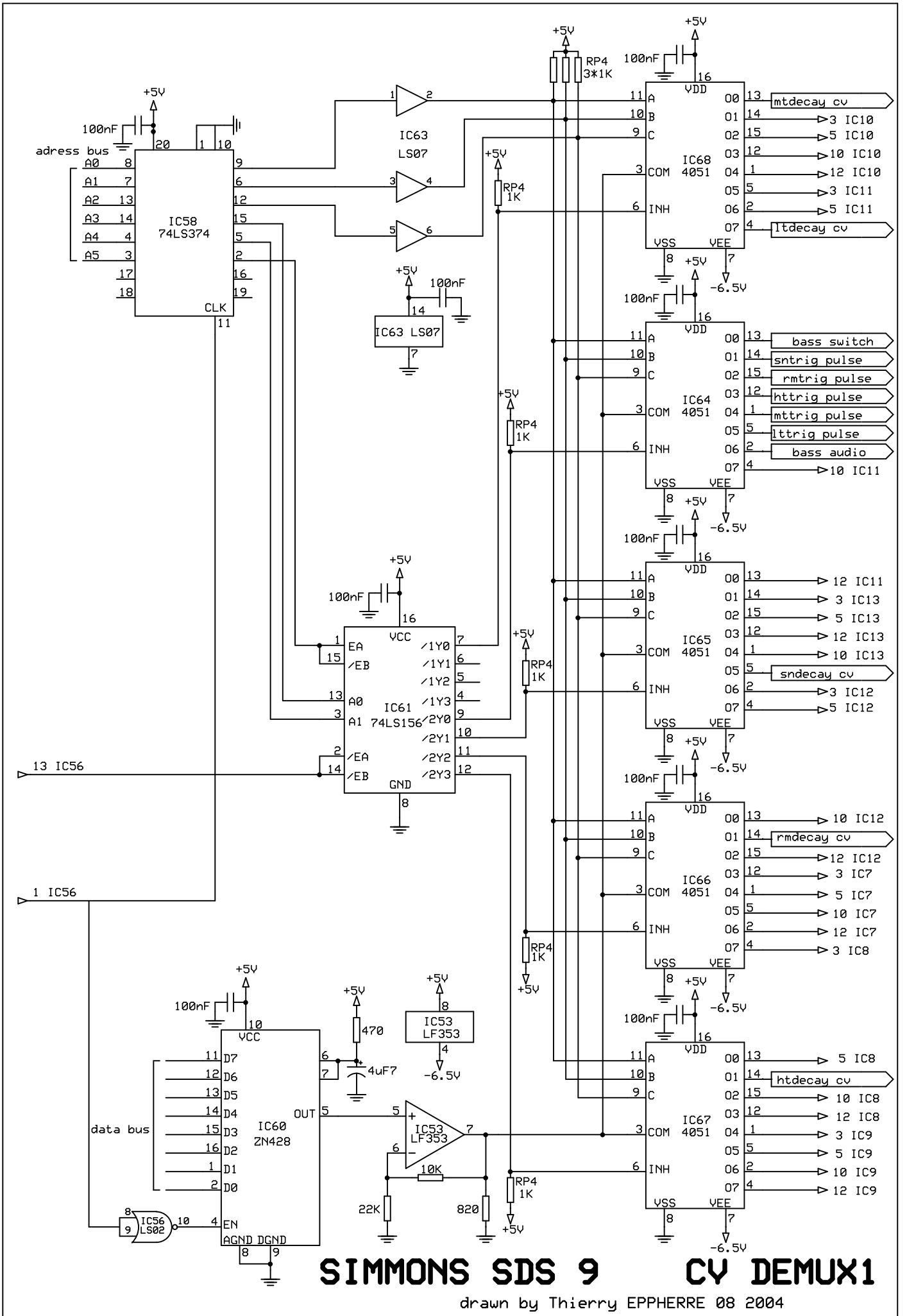

# SIMMONS SDS 9 CV DEMUX1

drawn by Thierry EPPHERRE 08 2004

# SIMMONS SDS 9 CV DEMUX2

drawn by Thierry EPPHERRE 08 2004

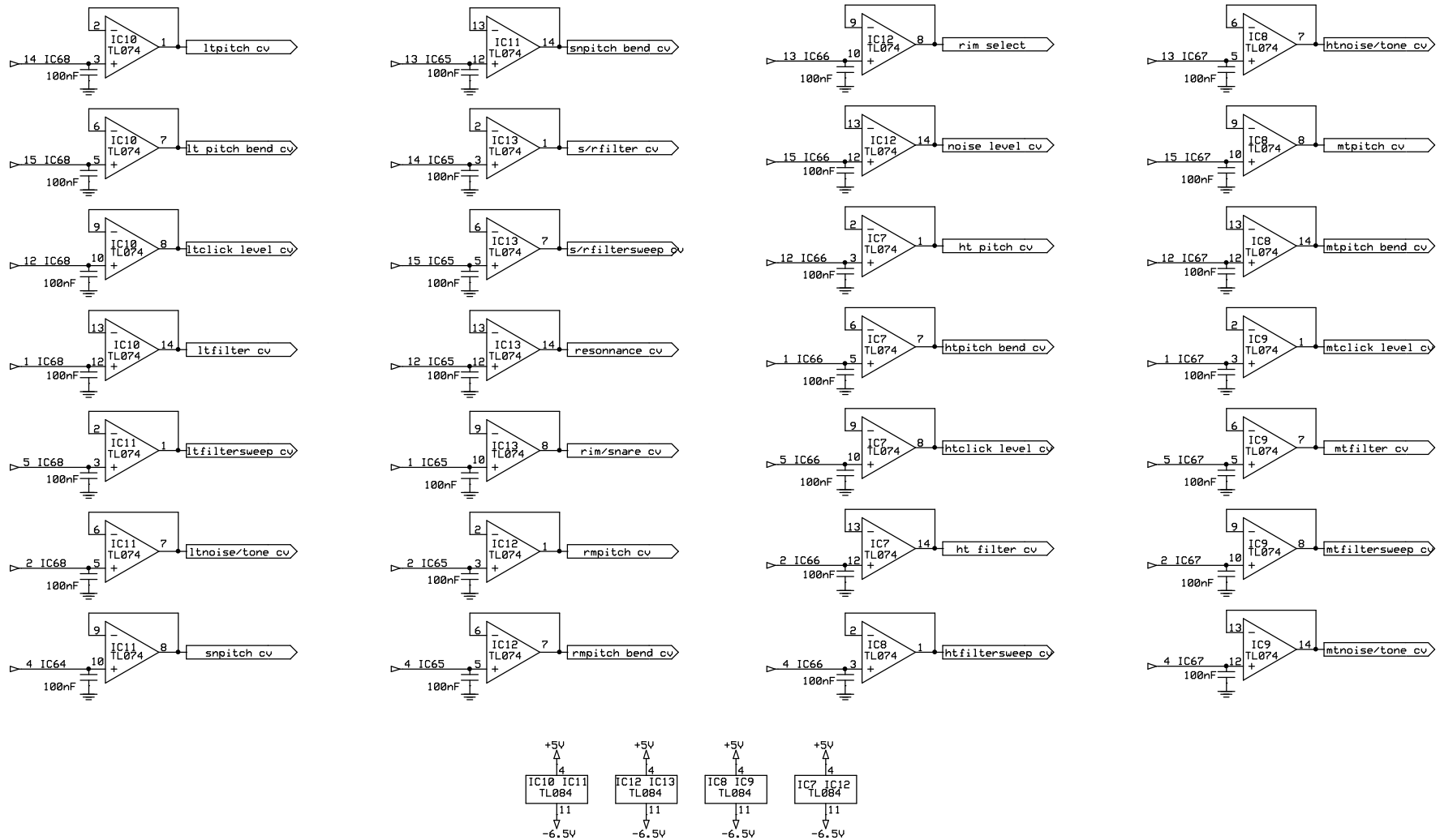

# SIMMONS SDS 9 MIDI & TAPE INTERFACE

drawn by Thierry EPPHERRE 08 2004

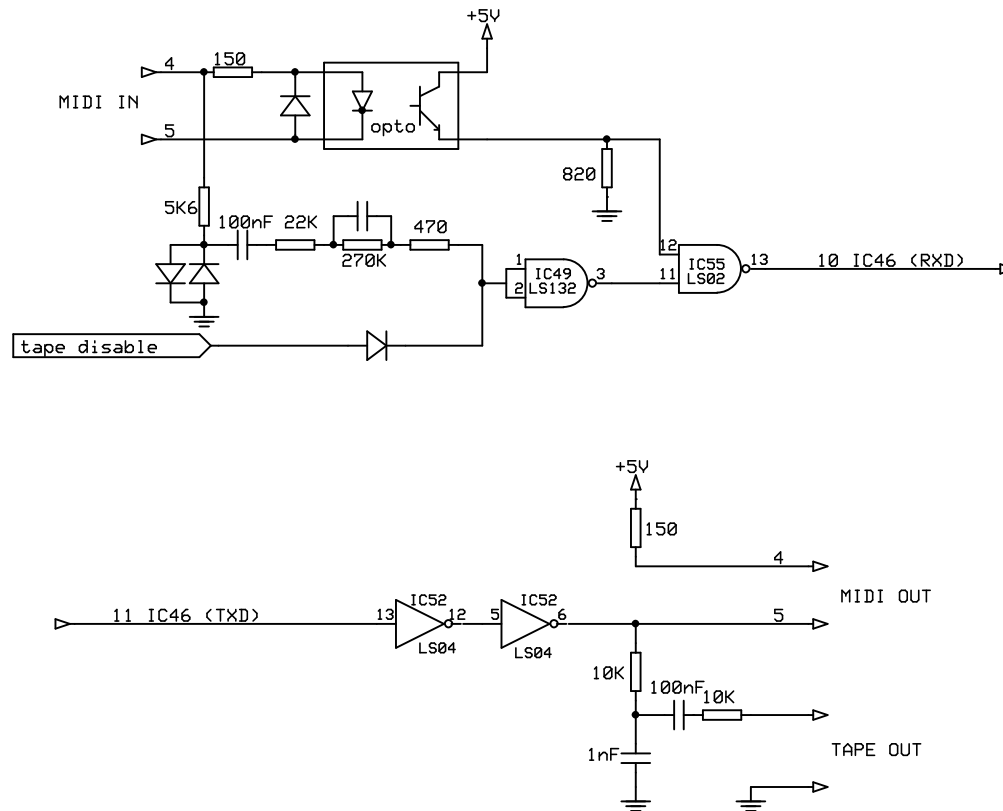



# SIMMONS SDS 9 BASS & Co

drawn by Thierry EPPHERRE 08 2004

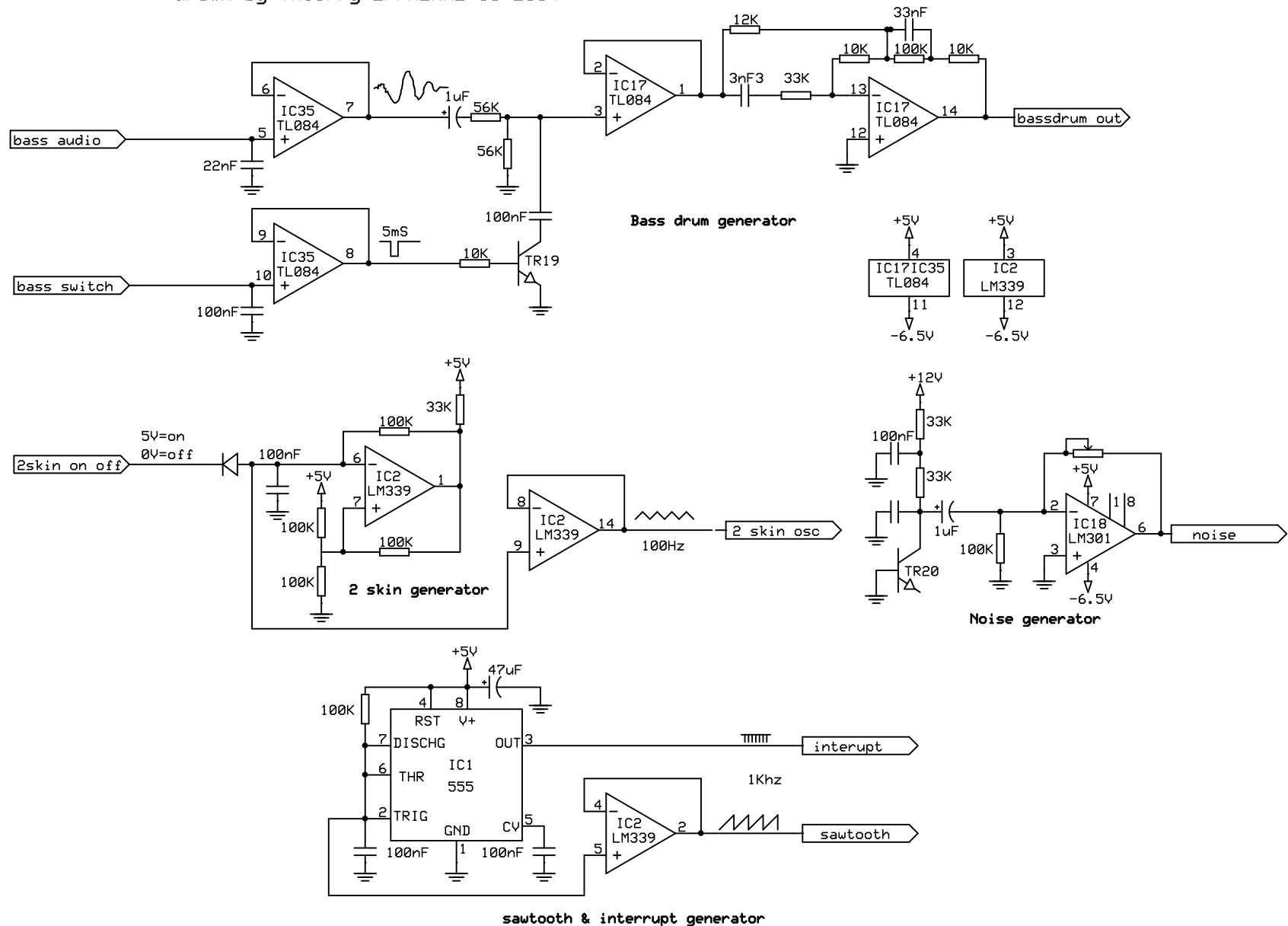

# SIMMONS SDS 9 HI TOM

drawn by Thierry EPPHERRE 08 2004

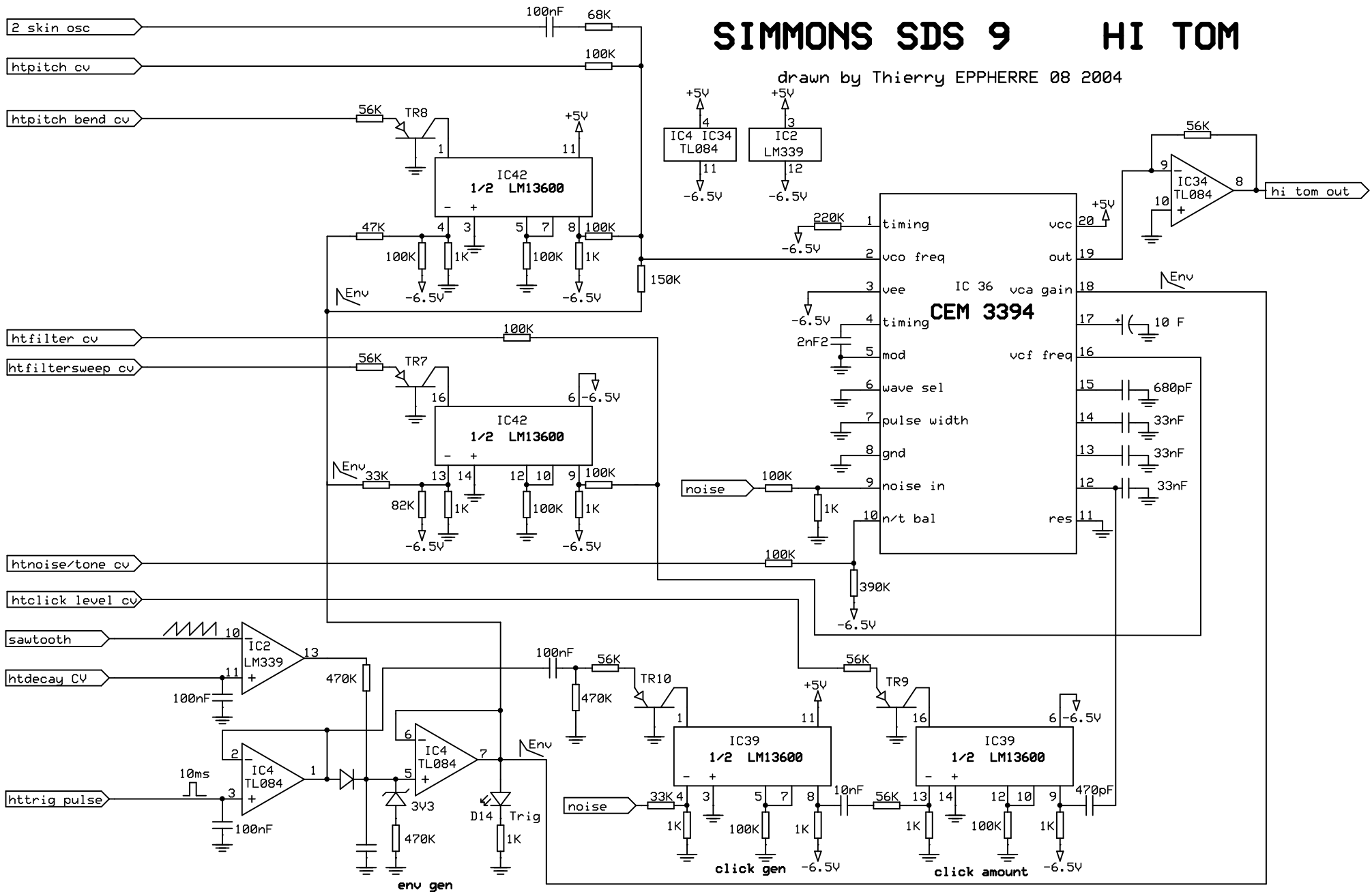

# SIMMONS SDS 9 MED TOM

drawn by Thierry EPPHERRE 08 2004

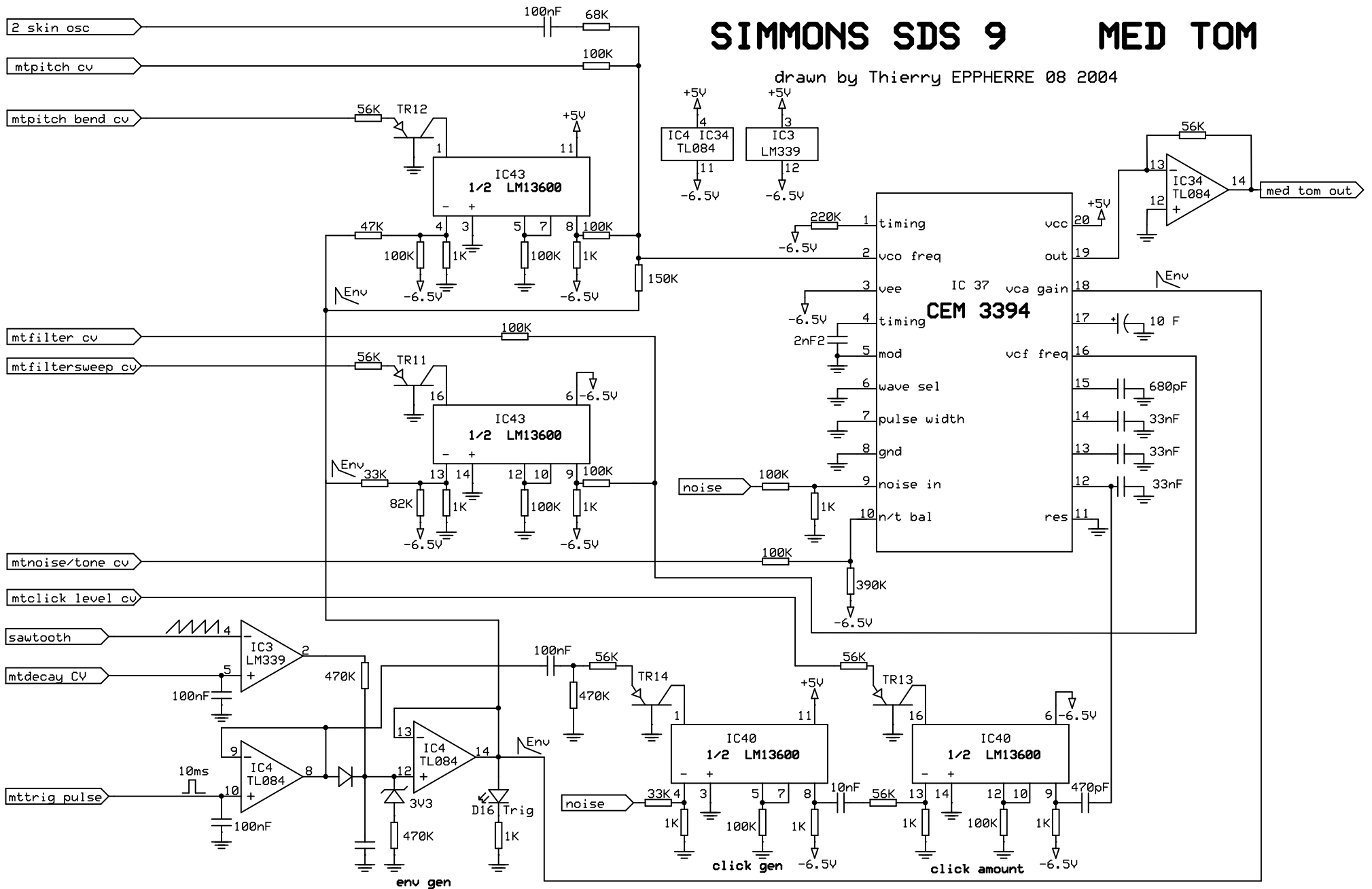





# SIMMONS SDS 9 RIM

drawn by Thierry EPPHERRE 08 2004

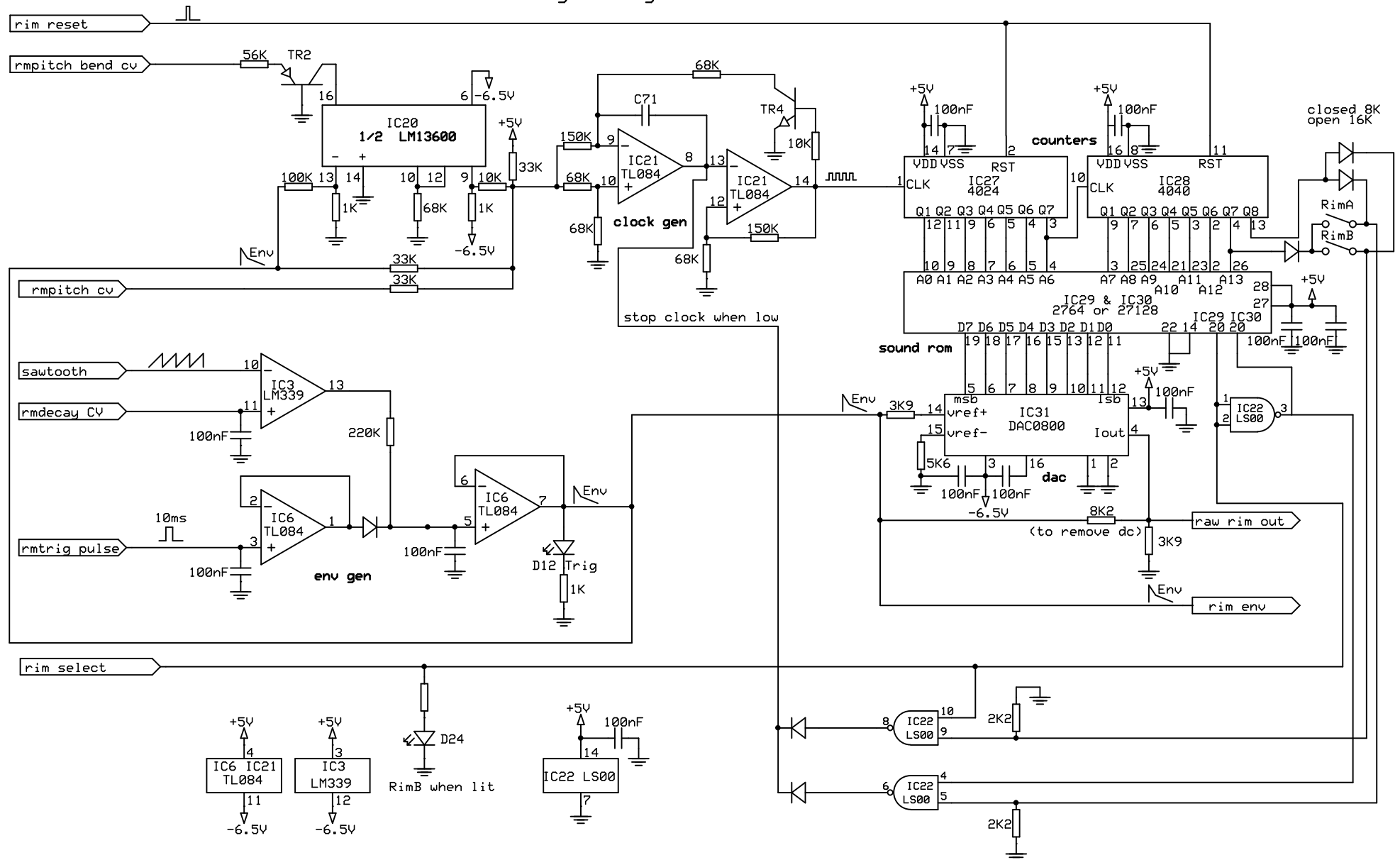

# SIMMONS SDS 9 SNARE & RIM FILTER

drawn by Thierry EPPHERRE 08 2004

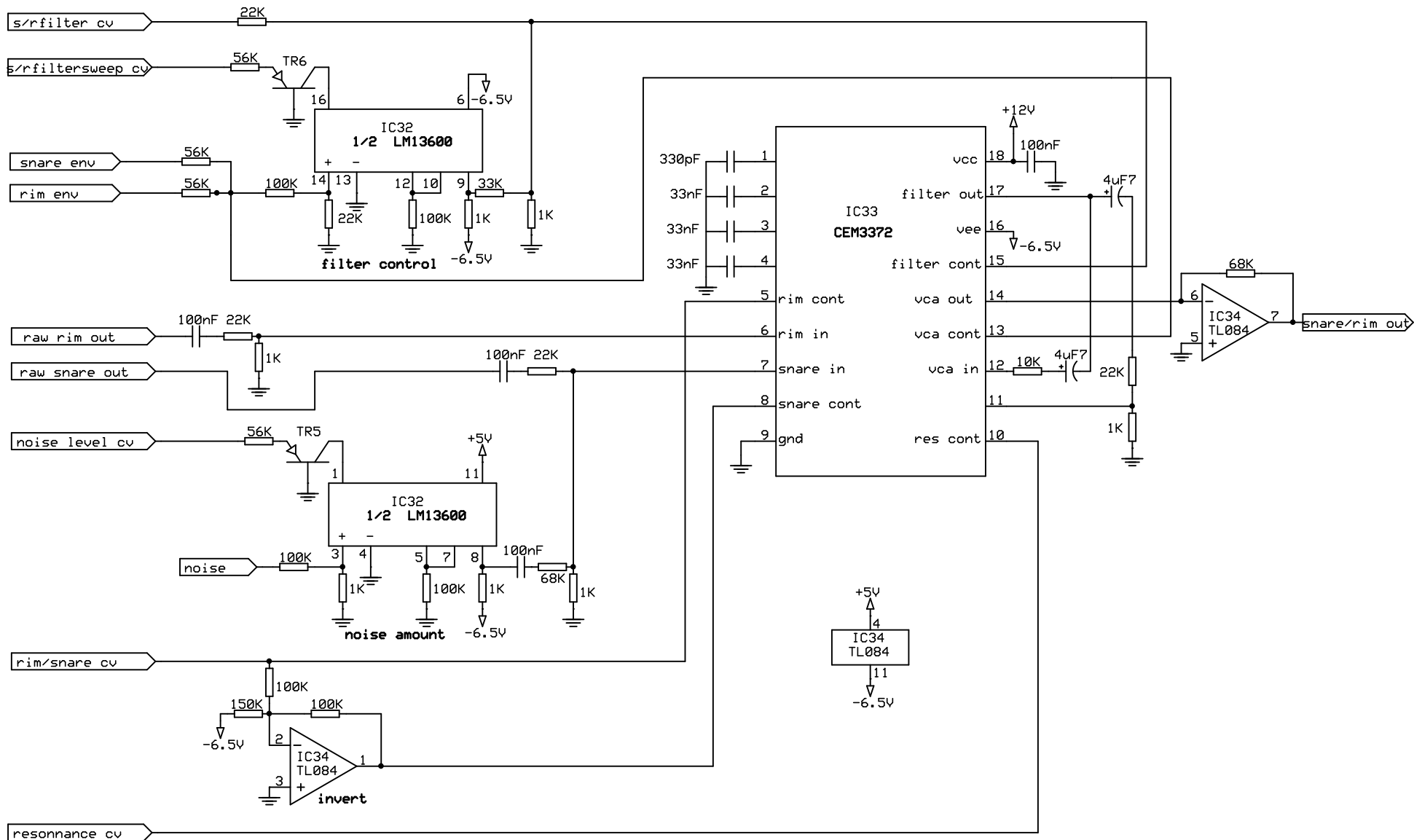

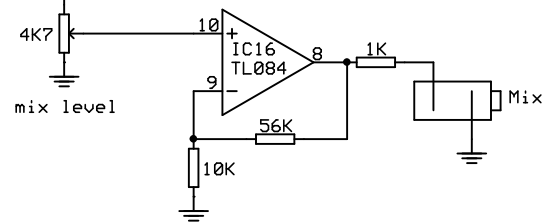
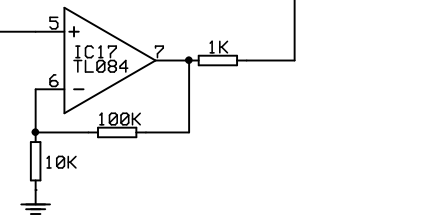
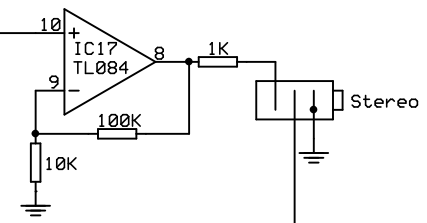
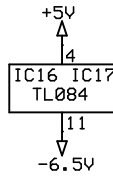
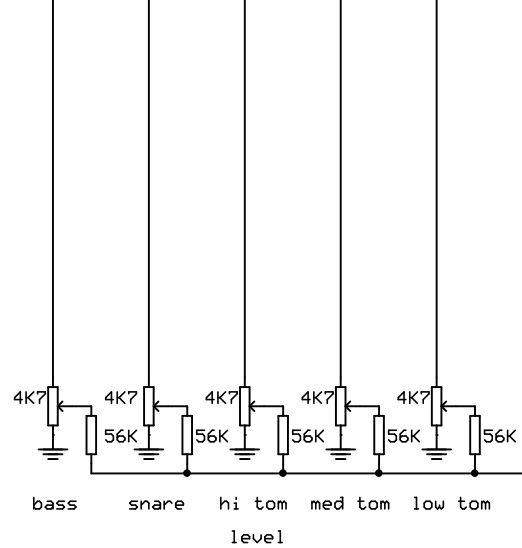
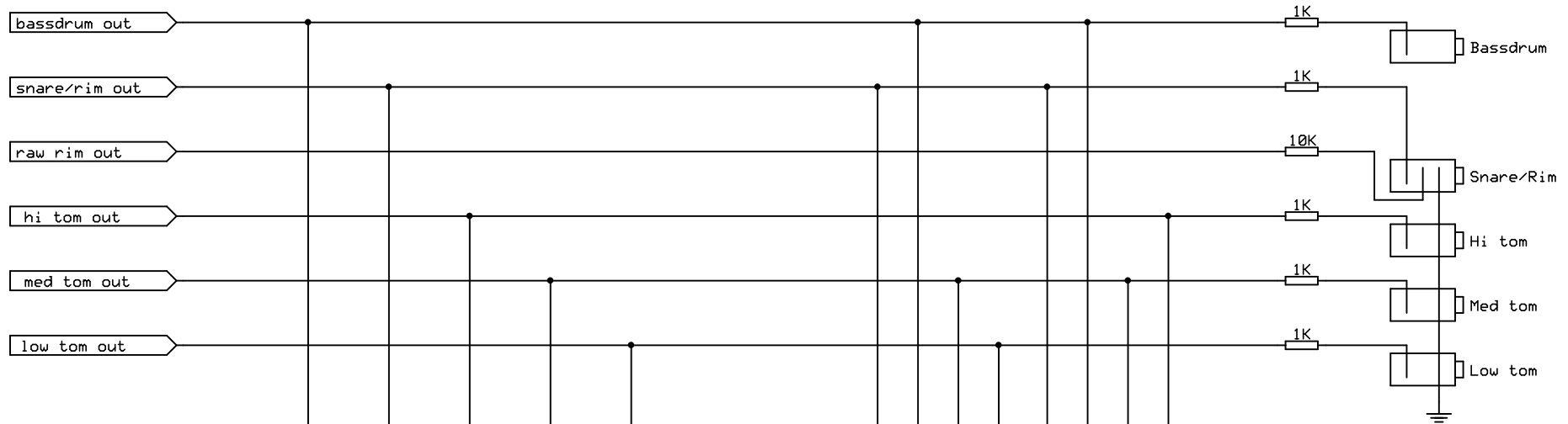

# SIMMONS SDS 9 OUTPUTS & MIXING

drawn by Thierry EPPHERRE 08 2004