

Notes: C

(Biscuits 78 to 85)

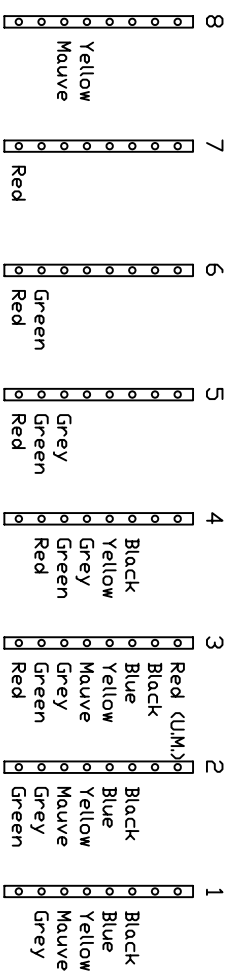

Notes: E, F, F#

(Biscuits 36 to 56)

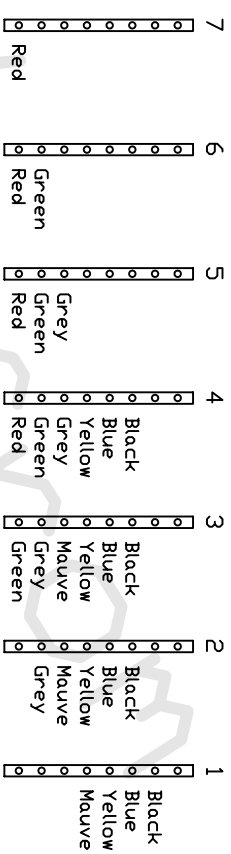

Notes: C#, D, D#

(Biscuits 57 to 77)

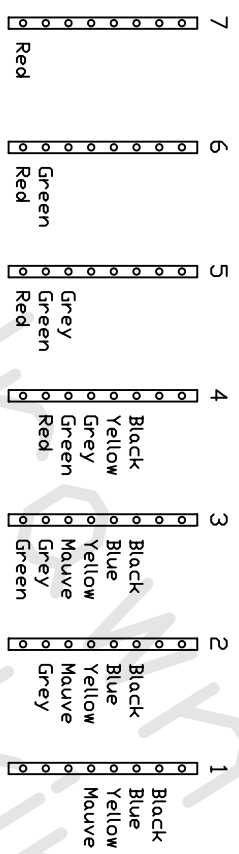

(Biscuits 29 to 35)

Notes: G

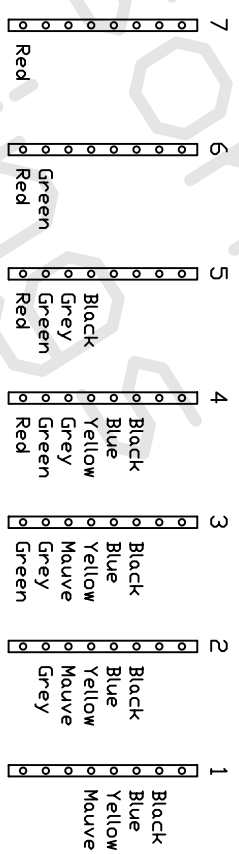

Key Contacts

Key Action

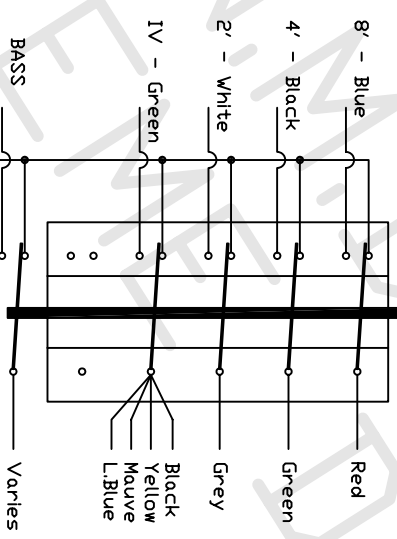

Note:

Biscuits number right to left (1 to 85)
Keys number left to right (1 to 49)
L.Blue only connected to Keys 1 to 44.
Maive only connected to Keys 1 to 37.
Bass contacts mounted under main key contact block - Keys 1 to 13

Notes: G#, A, A#, B
(Biscuits 1 to 28)

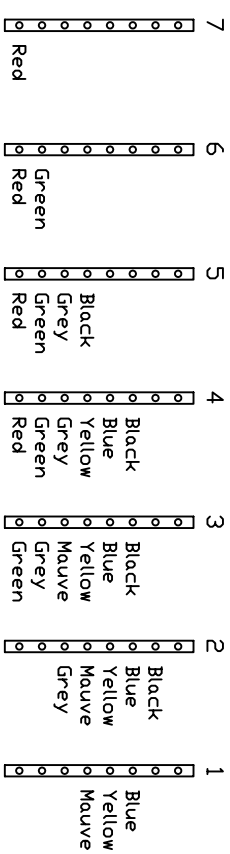

Scale		N.T.S.		Title		DRW.	
MATL				LOWER MANUAL - BISCUIT & KEY SCHEMATIC FOR CONTINENTAL 300 & 301		CHK.	
FIN						APP.	
TOL.		Resistors 5% Capacitors 10%		VDX THOMAS ITALIAN EME MODEL		DRG. No. 002-800-002	
						NMD	

Notes: C

(Biscuits 78 to 85)

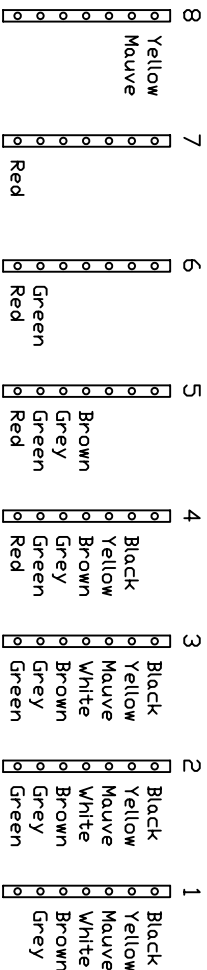

Notes: E, F, F#

(Biscuits 36 to 56)

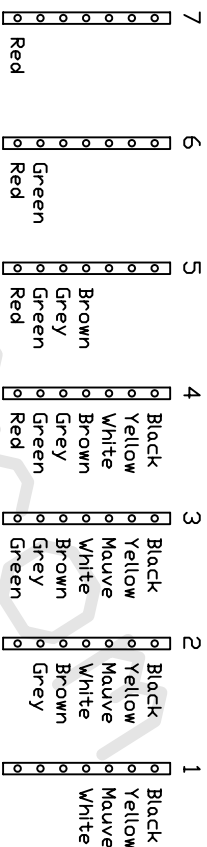

Notes: C#, D, D#

(Biscuits 57 to 77)

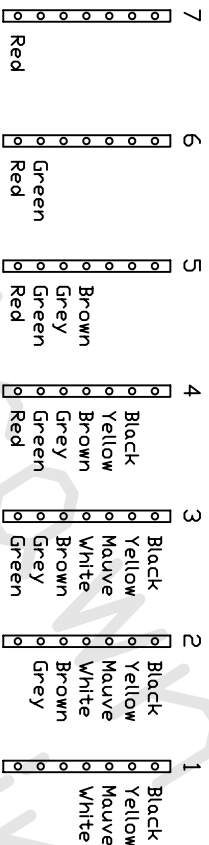

(Biscuits 29 to 35)

Notes: G

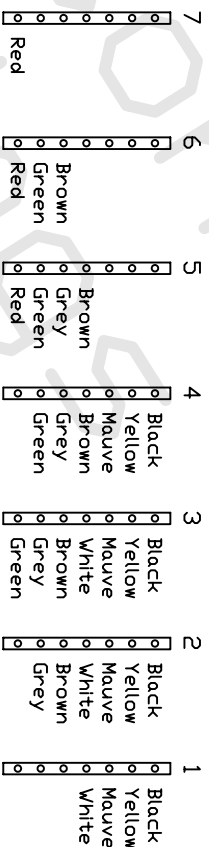

Note:

Biscuits number right to left (1 to 85)
 Keys number left to right (1 to 49)
 White only connected to Keys 1 to 44.
 Mauve only connected to Keys 1 to 37.
 Percussion contacts mounted under main key contact block

Key Contacts

Key Action

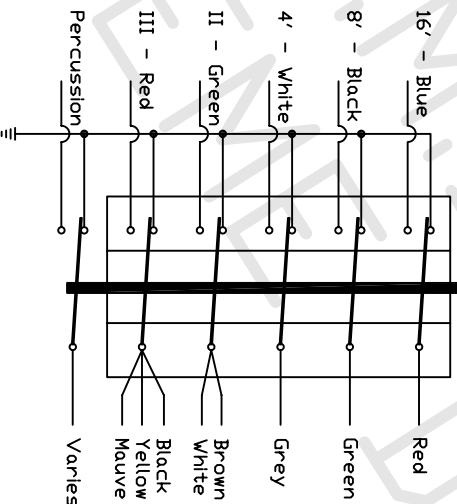

Notes: G#, A, A#, B
(Biscuits 1 to 28)

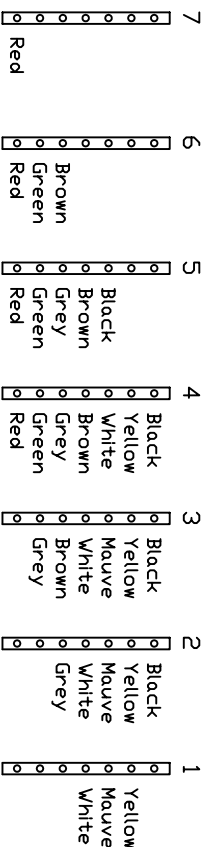

Scale		N.I.T.S.		Title		D.R.N.		N.M.D.	
M.A.T.L.				UPPER MANUAL - BISCUIT & KEY SCHEMATIC FOR CONTINENTAL 300 & 301		C.H.K.			
F.N.I.						A.P.P.			
T.D.L. Resistors 5% Capacitors 10%				V.D.X THOMAS ITALIAN E.M.E MODEL				D.R.G. No. 002-800-001	

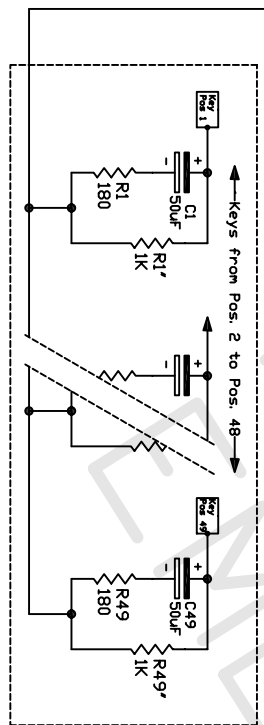
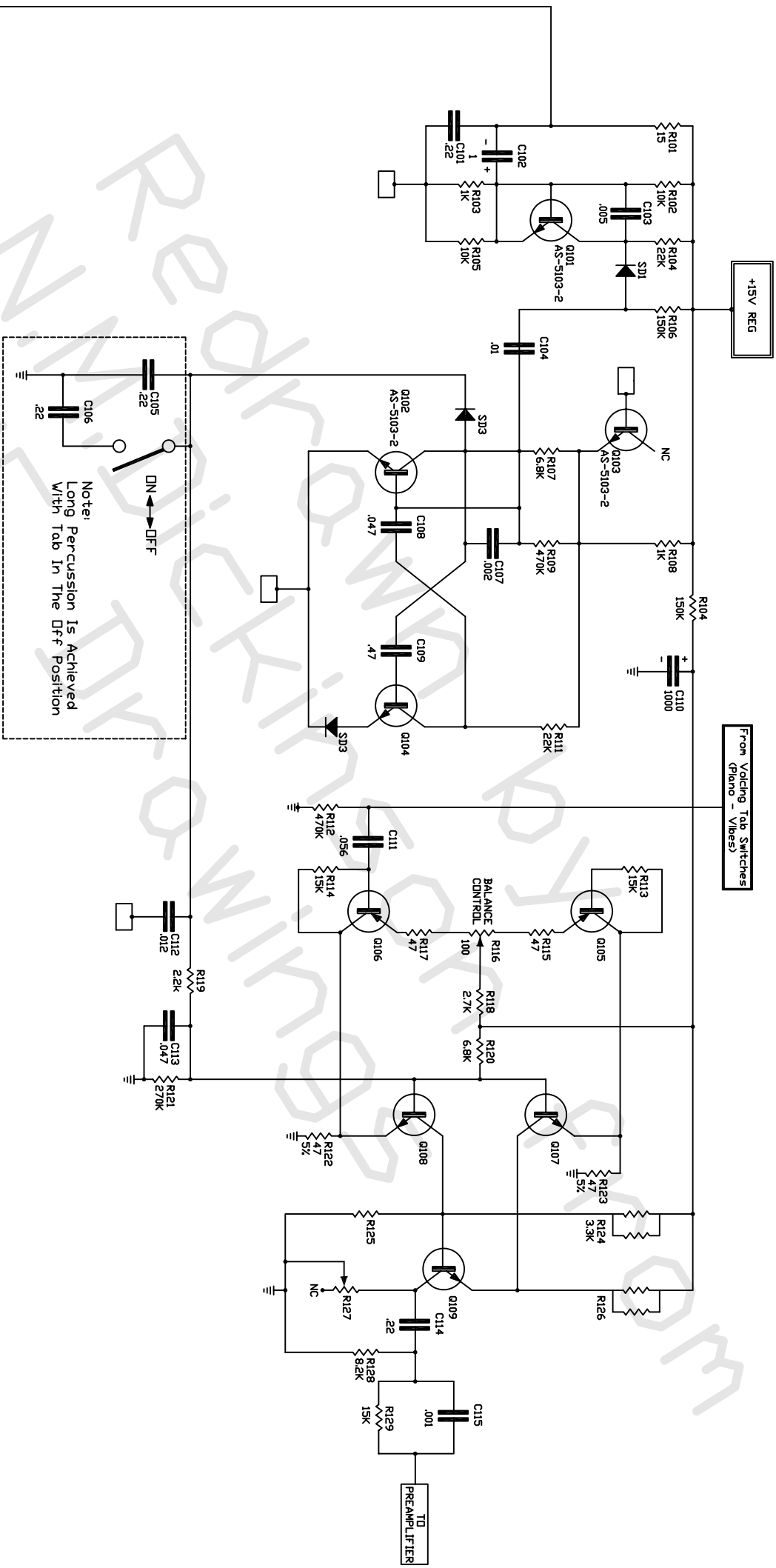

Title		Scale		N.T.S.	
PERCUSSION CIRCUIT FOR CONTINENTAL 300 & 301		MATL			
VOX THOMAS ITALIAN EME MODEL		FIN			
DRN		APP.		NMD	
DRG. No. 002-800-225					
TOL. Resistors 5% Capacitors 10%					

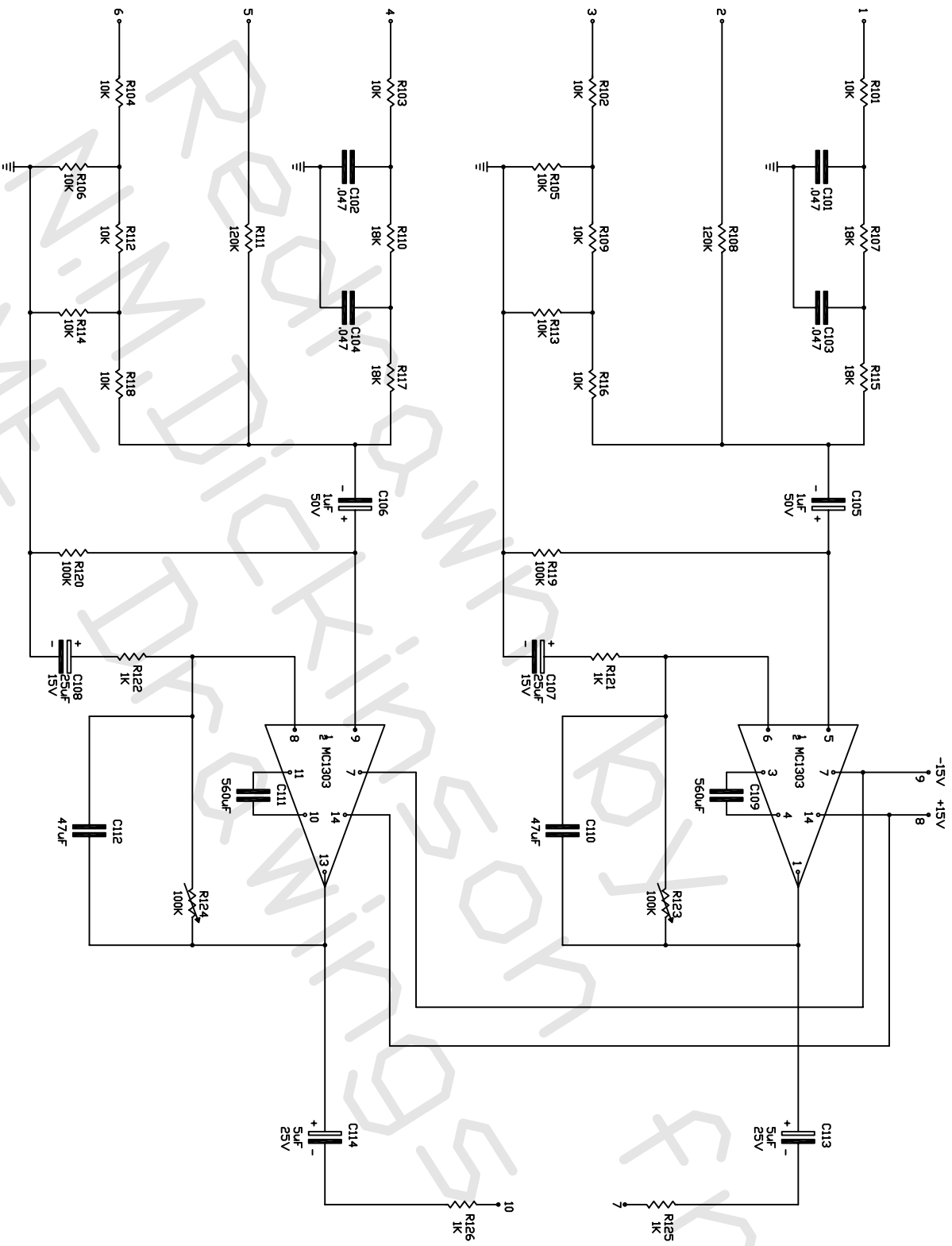

Scale		N/T S.		Title	
MATH				PRE AMPLIFIER FOR	
FIN				CONTINENTAL 300 & 301	
TOL.		Resistors 5%		VDX THOMAS	
		Capacitors 10%		ITALIAN EME MODEL	
				DRN. NMD	
				CHK.	
				APP.	
				DRG. No.	
				002-800-196	

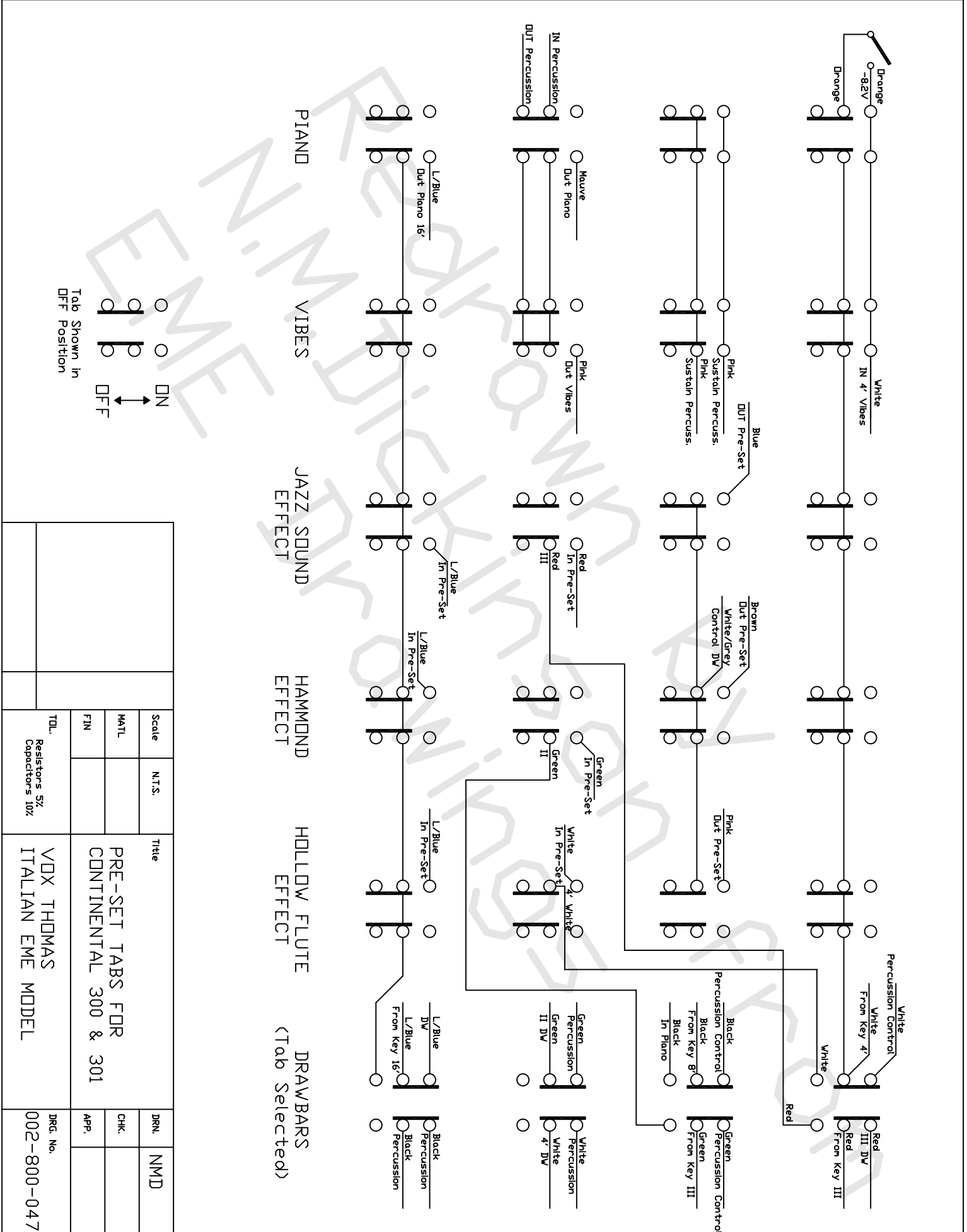

PIANO

VIBES

JAZZ SOUND EFFECT

HAMMOND EFFECT

HOLLOW FLUTE EFFECT

DRAWBARS (Tab Selected)

Tab Shown in DFF Position

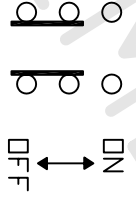

Scale		N.T.S.		Title		DRN.	NMD
MATL				PRE-SET TABS FOR CONTINENTAL 300 & 301		CHK.	
FIN				VOX THOMAS ITALIAN EME MODEL		APP.	
TDL.		Resistors 5% Capacitors 10%				DRG. No.	002-800-047

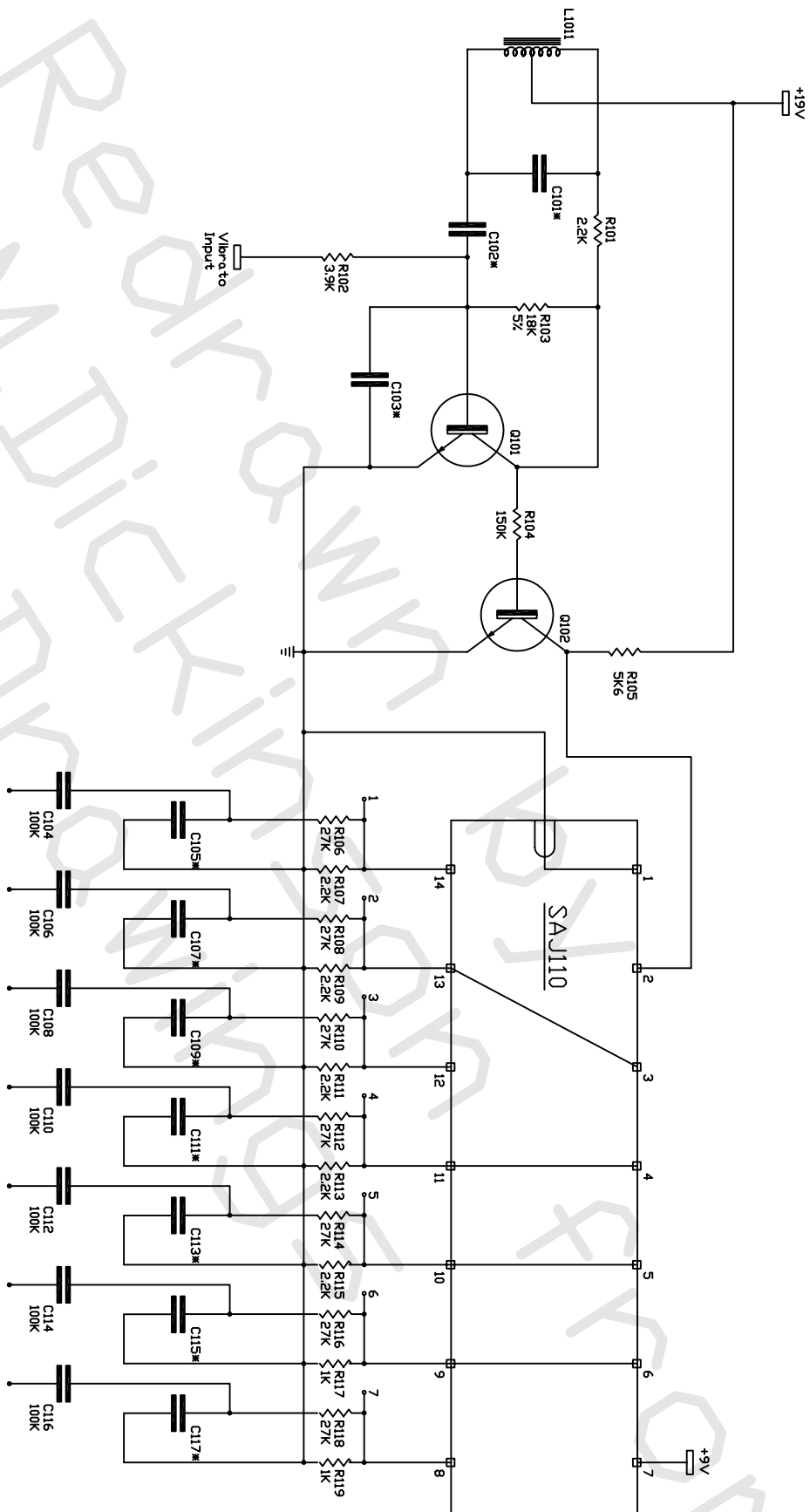

Note	C,C#,D,J#	E,F,F#,G	G#,A,A#,B
C101	6.8K 5%	4.3K 5%	2.8K 5%
C102 C103	10K 10%	8.2K 10%	6.8K 10%
C105	1.5K	1K	680pF
C107	3.3K	2.2K	1.5K
C109	6.8K	5K	3.3K
C111	12K	10K	6.8K
C113	27K	22K	15K
C115	47K	4.3K	3.3K
C117	91K	82K	68K

Scale		Scale		Title		DRN.	
MATL		Capacitors 10%		TONE GENERATOR FOR CONTINENTAL 300 & 301		NMD	
FIN		Resistors 5%		VOX THOMAS ITALIAN EME MODEL		CHK.	
TDL.		Capacitors 10%		APP.		DRG. No.	
						002-800-183	

Central
Tone Drawbars Jazz Sound Hammond Effect Hollow Flutes

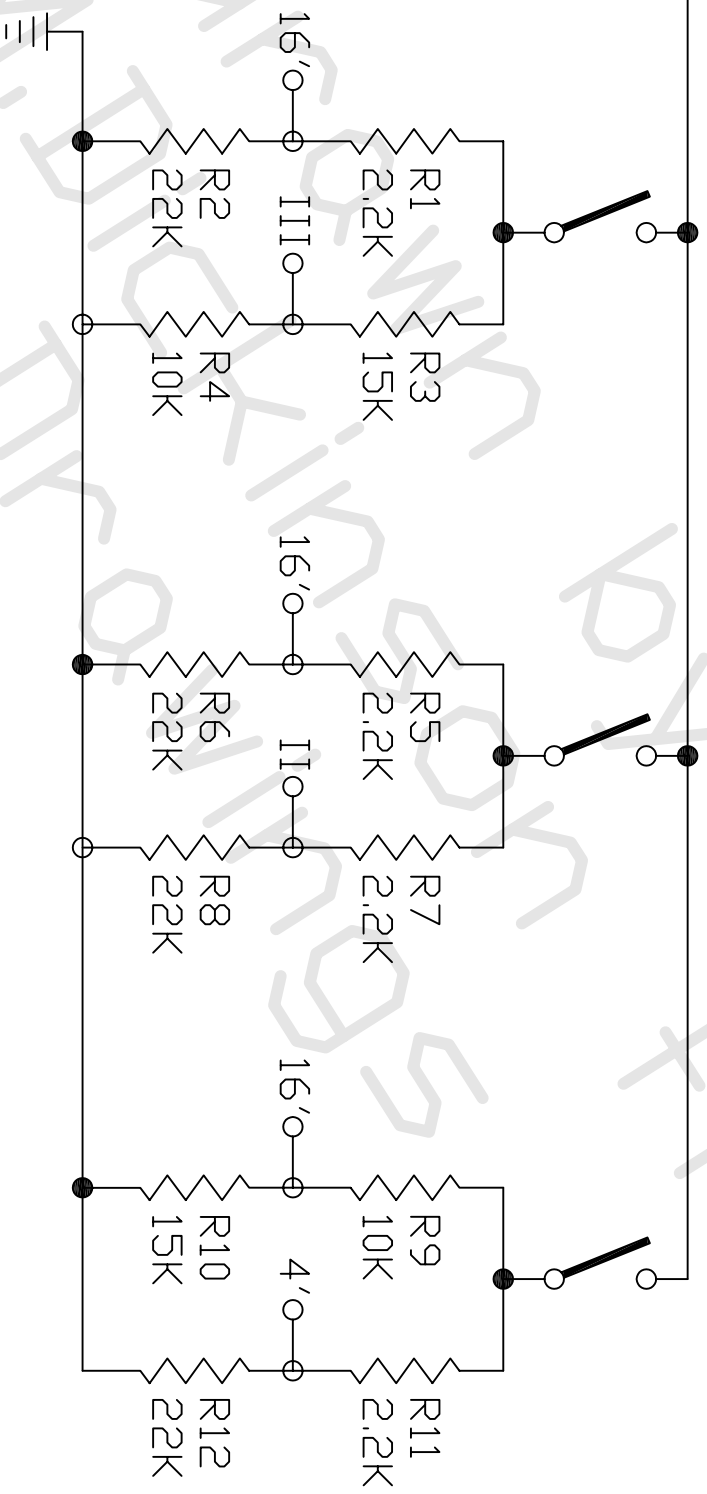

Scale		N.T.S.		Title	
MATL				TONE PRE-SET CIRCUIT	
FIN				CONTINENTAL 300 & 301	
TDL		Resistors 5% Capacitors 10%		VOX THOMAS ITALIAN EME MODEL	
DRN.		NMD		DRG. No.	
CHK.				002-800-220	
APP.					