

# Service Manual

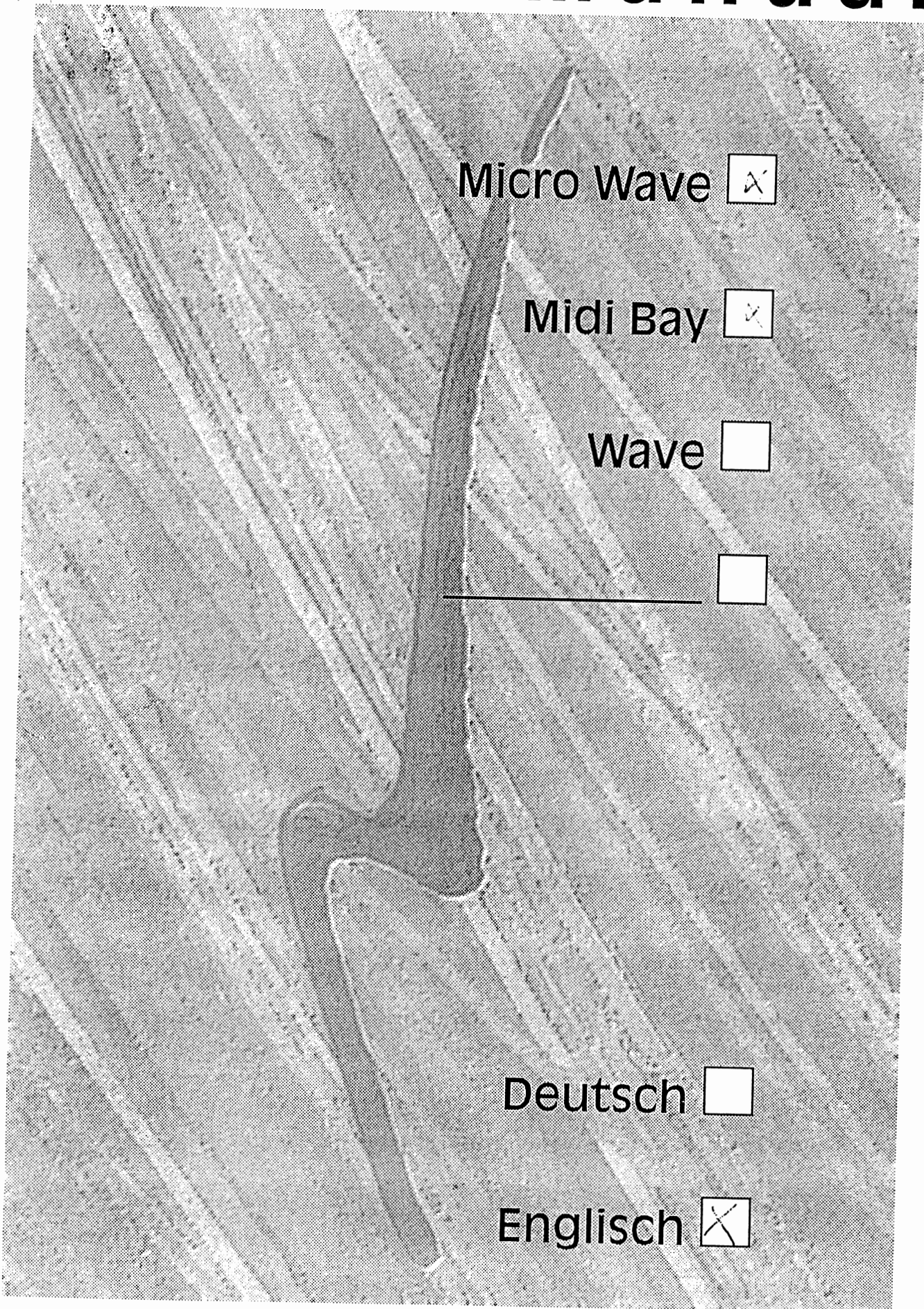

Micro Wave

Midi Bay

Wave

Deutsch

Englisch

Waldorf Electronics GmbH • Neustr. 9 • D - 53498 Waldorf

**Verwaltung / Produktion**

☎ D-(0) 26 36 / 76 32  
☎ D-(0) 26 36 / 79 35  
Neustraße 9  
D - 53498 Waldorf

**Design**

☎ D-(0) 26 36 / 8 02 05  
☎ D-(0) 26 36 / 8 01 88  
Hauptstraße 71  
D - 53498 Waldorf

**Research & Development**

☎ D-(0) 26 36 / 8 02 94  
☎ D-(0) 26 36 / 8 01 88  
Hauptstraße 71  
D - 53498 Waldorf

Technical documentation 4

Manual for the MicroWaves's Service-mode

Connect the MicroWave's audio-output "Left" and "Right" to an amplification system.

To get into Service mode hold the \*Mode-button\* when powering up and release it immediately when the message

> Welcome to the Microwave <

is displayed.

Now the display will read

> Warning! Entering this mode will destroy all stored data... <.

- Press the \*OK button\*.

> Software Version <

> V X.XX - YY/MM/DD < (version - release date year/month/day)

will be displayed.

HINT: by pressing the \*Mode button\* each test-routine can be directly selected. You have to repeatedly press the button to reach a certain test; should you pass by the desired test, keep on pressing - the test-routines will cycle.

- Press the \*Mode button\*.

> System Runtime: <

> hhhhhh:mm < (hours:minutes)

will be displayed.

- Press \*Mode button\*.

> Memory Init & Test <  
> Status: WRAM: ? <

This test-routine must only be done after exchanging the batteries, since all system-programming has been done prior by the factory. Should for whatever reason an initialization be mandatory, do the following steps:

- ATTENTION!! Back up all internal memory to a cartridge. Consult the manual under "Data Transfer" for details.
- ATTENTION!! Use a different card for the following test-routine. You MUST insert a card, otherwise the test will fail and the op-sys will crash!

- Acknowledge the routine by pressing the \*OK button\*.

> Status : ICRT: ? < Internal Sound-RAM-check

- Acknowledge the routine by pressing the \*OK button\*.

> Status : INIT: ? < Initializing the Sound-RAM.

- Acknowledge the routine by pressing the \*OK button\*.

> Status : ECRT: ? < External Card test.  
If the Write-protect switch is set to "ON" the Card cannot be written to; An "ERR" will be displayed.

- Acknowledge the routine by pressing the \*OK button\*.

> Status : COPY: ? < Datacopy from Card to RAM

- Acknowledge the routine by pressing the \*OK button\*.

End of Memory-Test.

- Press the \*Mode button\*.

> Keyboard Test <

will be displayed.

- Press each button and watch for a corresponding display-message  
(see figure for details)

HINT: press the \*Mode button\* last, since it will forward you to  
the next test-routine.

- Press the \*Mode button\*.

> LED Test <

will be displayed.

- Press the \*OK button\* to step through and illuminate each LED.  
(see figure for details)

- Press the \*Mode button\*.

> Midi Test <

> Status: <

will be displayed.

- Connect the MicroWave's MIDI-IN port to it's own MIDI-OUT port.

- Acknowledge the routine by pressing the \*OK button\*.

- Press the \*Mode button\*.

> Voice Test <

> Voice # X to Out # Y <

will be displayed.

- Press the \*OK button\* repeatedly to connect all eight voices  
sequentially to the Left and Right audio-output. Voices #1  
through #4 will additionally be output at their respective  
Single-out's. To check those, connect the Left-output cable  
momentarily to the desired Single-output.

You will hear a sine-wave of 123,5 Hz.

- Press the \*Mode button\*.

```
> Filter Freq.Adj <  
> Voice # X      <
```

will be displayed.

HINT: Only tune the filters after the MicroWave has reached it's working-temprature.

- Connect a tuner to one of the audio-outputs. The tuner must be able to display A 2 = 440 Hz.

- Press the \*OK button\* to select the first voice.

- Use the \*Alpha dial\* to finetune the filter-frequency of this voice. When the tuner displays 440 Hz (A 2), the filter is tuned. The \*Alpha dial\* covers a range og +/- a semitone.

Should that not be enough, you must open the unit recalibrate the coarse-tuning of the filter. Use Pot R 5 for voice #1, Pot R 12 for voice #2, R 19 for voice #3 and the like.

- If you didnt' forget to check the Single-Outputs your done.  
Have coffee.

End of MicroWave test-routines

LED'S

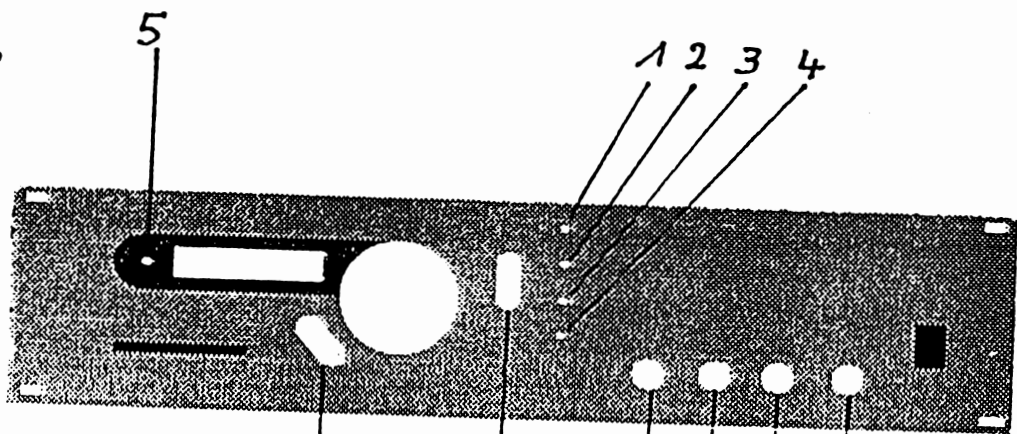

BUTTONS

6 5 4 3 2 1

5/5

Waldorf Electronics GmbH • Neustr. 9 • D - 53498 Waldorf

**Verwaltung / Produktion**

☎ D-(0) 26 36 / 76 32  
☎ D-(0) 26 36 / 79 35  
Neustraße 9  
D - 53498 Waldorf

**Design**

☎ D-(0) 26 36 / 8 02 05  
☎ D-(0) 26 36 / 8 01 88  
Hauptstraße 71  
D - 53498 Waldorf

**Research & Development**

☎ D-(0) 26 36 / 8 02 94  
☎ D-(0) 26 36 / 8 01 88  
Hauptstraße 71  
D - 53498 Waldorf

TECHNICAL INFO 5  
-----

Checking the display

- Failure: No display illumination (Flickering)

The MicroWave's display is powered by the frontboard.  
The upper wire-connection on the right-hand side of the display must carry + 5 V.

The lower wire-connection is made to ground.  
The wire-connections must be passed through the upper board on the display as well as being soldered to the second smaller board.

The sixteen-core flat line carries the needed voltage from the front- to the digital-board. Pin 1 (+ 5 V) and Pin 2 (Ground).

Pin identification of the flat line to the front board:  
Component side, Midi sockets at the rear, Pin 1 is always to the right.

The 4th ten-core flat line carries the voltage between the digital- and the analog-board (Pin 40/39 Ground, Pin 38/37 + 5 V).

Pin identification of the flat line to the Analog board:  
Component side, Midi sockets at the rear. Pin 40 Midi socket side, Pin 1 front board side.

+ 5 V will be generated from the power pack (power regulator 7805 on the cooling plate). Check if the power regulator is well fixed to the cooling plate (Ground).

T/I MW 5.1

## Checking the Display

- Failure: Empty display (after Eprom change)

1. The position of the Eproms has changed from Serial No. 91 2 1682 caused by a Digital-board re-design.  
The Low- and High-Eproms are interchanged. If necessary, change.
2. The Eprom notches must face into the unit.
3. Check that all pins are in the IC socket.
4. Try the original, or a different Eprom set. If the fault is removed, the new Eproms are probably defective.
5. Check if the board trace below the sockets are accidentally been damaged by changing the Eproms.
6. If the fault cannot be removed, check if all signals are received by the display.

As specified in the circuit diagramm, the data lines D7/Pin 14 to D0/Pin 7 are at the display. In addition, at Pin 6 is the enable-line, at Pin 5 is the Read/Write lead, and at Pin 4 the address-line A1.

Pin 3 and Pin 1 are at ground and at Pin 2 the 5 V power supply.

If one ore more signals cannot be measured, check the flat line to the display and the digital-board for breaks, dry junctions or solder bridging.



Waldorf Electronics GmbH • Neustr. 9 • D - 53498 Waldorf

**Verwaltung / Produktion**

☎ D-(0) 26 36 / 76 32  
☎ D-(0) 26 36 / 79 35  
Neustraße 9  
D - 53498 Waldorf

**Design**

☎ D-(0) 26 36 / 8 02 05  
☎ D-(0) 26 36 / 8 01 88  
Hauptstraße 71  
D - 53498 Waldorf

**Research & Development**

☎ D-(0) 26 36 / 8 02 94  
☎ D-(0) 26 36 / 8 01 88  
Hauptstraße 71  
D - 53498 Waldorf

TECHNICAL INFO 6  
-----

Manual for the Service mode of the MidiBay

To get into the Service mode hold both the Mode- and Panic-buttons when powering up.

When two horizontal lines are displayed release the Mode-button first and then the Panic-button.

- Press the Down-button.

\* L t (LED test) will be displayed.

Start test with the Up-button.

One after the other, all display elements and the two LED's must illuminate shortly.

ADVICE: The Mode-button allows every test to be adressed directly.

- Press the Down-button.

\* S t (Switch test) will be displayed.

Start test with the Up-button.

\* P 1 will be displayed. Confirm with Mode button.

\* P 2 will be displayed. Confirm with Down button.

\* P 3 will be displayed. Confirm with Up button.

\* P 4 will be displayed. Confirm with Panic button.

T/I MB 6.1

\* t o (Test o.k.) will be displayed shortly, then again

\* S t (Switch Test).

- Press the Down-button.

\* i o (In/Out test) will be displayed.

This test checks the remote-control and footswitch-port on the front board, but can only be made with the assistance of special adaptors.

This test is irrelevant for the normal function of the MidiBay.

The function of the footswitch-port can be checked during normal operation with a footswitch.

- Press the Down-button.

\* M t (Midi test) will be displayed.

Connect all inputs to their respective outputs with MIDI leads. In other words, connect Destination 1 with Source 1, Destination 2 with Source 2, Destination 3 with Source 3, etc.

Start the test with the Up-button.

The numbers \* 1 - 15 will be displayed rapidly, then \* t o (Test o.k.) and the green LED will illuminate.

If there is a faulty In/Output \* E (Error) will be displayed with the corresponding In/Output number. The red LED will illuminate.

ADVICE: In/Out-port 15 and MIDI Aux-port (15) on the frontboard are switched in parallel, and must therefore also be checked with the help of a MIDI cable.

The MIDI-ports situated on the frontboard have higher priority, since behind the Source-port a switch is installed which interrupts the corresponding In/Outputs situated on the back panel.

- Press the Down-button.

\* r t (Ram Test) will be displayed.

Confirm with the Up-button.  
If no failure in the RAM can be located,

\* t o (Test o.k.) will be displayed.

- Press the Down-button.

\* c r (Clear Ram) will be displayed.

Confirm with the Up-button.

By executing this function, the unit will be initialised.  
This means that all programmes will be set into an exactly defined  
zeroposition. (Only necessary after battery or RAM changes).

ADVICE: All user programmes will be lost.

All tests finished. The unit will leave the Service mode and return to  
normal operation condition.

Waldorf Electronics GmbH • Neustr. 9 • D - 53498 Waldorf

**Verwaltung / Produktion**

☎ D-(0) 26 36 / 76 32  
☐ D-(0) 26 36 / 79 35  
Neustraße 9  
D - 53498 Waldorf

**Design**

☎ D-(0) 26 36 / 8 02 05  
☐ D-(0) 26 36 / 8 01 88  
Hauptstraße 71  
D - 53498 Waldorf

**Research & Development**

☎ D-(0) 26 36 / 8 02 94  
☐ D-(0) 26 36 / 8 01 88  
Hauptstraße 71  
D - 53498 Waldorf

TECHNICAL INFO 7

Storage loss in MidiBay

**Fault:** After switching on the unit, loss of stored data in the internal RAM.

**Solution:** Stabilisation of the reset circuit by installation of a transistor (BC 338) and a resistor (2K1).

Installation hints:

Solder the collector of the transistor to Pin 4 of IC LS/HCT 04 (U 8).  
Solder the base via a 2K1 resistor to Pin 2 of IC LS 14 (U 16).  
Solder the emitter against ground to Pin 7 of IC LS/HCT 04 (U 8).

Positioning the transistor:

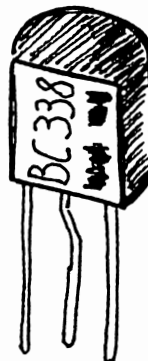

C B E

Initialisation must follow after installation.  
(See technical info 6)

T/I MB 7

Waldorf Electronics GmbH • Neustr. 9 • D - 53498 Waldorf

**Verwaltung / Produktion**

☎ D-(0) 26 36 / 76 32  
☎ D-(0) 26 36 / 79 35  
Neustraße 9  
D - 53498 Waldorf

**Design**

☎ D-(0) 26 36 / 8 02 05  
☎ D-(0) 26 36 / 8 01 88  
Hauptstraße 71  
D - 53498 Waldorf

**Research & Development**

☎ D-(0) 26 36 / 8 02 94  
☎ D-(0) 26 36 / 8 01 88  
Hauptstraße 71  
D - 53498 Waldorf

TECHNICAL INFO 8

-----

Checking the cartridge

**Failure:** No data (sounds/multis) readable from cartridge.  
After transporting the unit the card-holder came loose and must be fixed again.

**Solution:** Open the unit and insert cartridge.  
A 34-core frame connector is situated on the left hand side of the card-holder board.  
This frame-connector is soldered underneath the board and sticks into a 34-core socket-ledge.

**Hint:** At this ledge Pin 1,2 & 4 are not used. For that reason some boards are only fitted with a 32-pole connection.

- Pin identification additional to the circuit diagramm:  
Component side, open side of the card-holder in front, frame-connector on the left-hand side.  
Pin 1 at the back, left. Pin 2 at the back, right. Pin 3 next line, left.

Unscrew and remove the board from the unit.  
Check the frame-connector for dry junctions or shorts.  
Plug in the board again and fix it tight to the socket-ledge.  
Insert a cartridge, adjust the board and screw tight.

If there is no more defect to find, the screws should be fixed with nail-varnish or the like.

TI/MW 8.1

Waldorf Electronics GmbH • Neustr. 9 • D - 53498 Waldorf

**Verwaltung / Produktion**

☎ D-(0) 26 36 / 76 32  
☎ D-(0) 26 36 / 79 35  
Neustraße 9  
D - 53498 Waldorf

**Design**

☎ D-(0) 26 36 / 8 02 05  
☎ D-(0) 26 36 / 8 01 88  
Hauptstraße 71  
D - 53498 Waldorf

**Research & Development**

☎ D-(0) 26 36 / 8 02 94  
☎ D-(0) 26 36 / 8 01 88  
Hauptstraße 71  
D - 53498 Waldorf

TECHNICAL INFO 9  
-----

MicroWave reset problems

(MW-serialnumbers 9211997 until 9222320 only!)

Failure: After switching on the unit, no display contents.

Solution: Wiring change of the reset circuit (Digital-board)

Installation hints:

- Exchange 10K resistor between pin 5 & 8 of IC 34 (TL 7705) for 1K resistor.
- Solder 1K resistor between pin 4 & 6 of IC 34.
- Exchange R 100 (10K resistor and 6K8 resistor) for one 4K7 resistor. (Next to IC 13/LS 14)

After changes have been done unit must be initialised.  
(see technical info 4)

TI/MW 9.1

Waldorf Electronics GmbH • Neustr. 9 • D - 53498 Waldorf

**Verwaltung / Produktion**

☎ D-(0) 26 36 / 76 32  
☎ D-(0) 26 36 / 79 35  
Neustraße 9  
D - 53498 Waldorf

**Design**

☎ D-(0) 26 36 / 8 02 05  
☎ D-(0) 26 36 / 8 01 88  
Hauptstraße 71  
D - 53498 Waldorf

**Research & Development**

☎ D-(0) 26 36 / 8 02 94  
☎ D-(0) 26 36 / 8 01 88  
Hauptstraße 71  
D - 53498 Waldorf

#10

Waldorf, January '93

Dear MicroWave Service Technician

We have re-designed the MicroWave analogue board. This analogue board will be installed from ser.# 9242517 onwards. Attached you will find the respective service information.

The board is technically and soundwise fully compatible to the existing analogue boards. Should the case occur that you have to replace an old analogue board against a new one, you will have to consider the following changes:

- R 007/3K3 on the digital board must be removed.  
(Resistance is situated next to transistor Q 01/BC328).
- Filter resonance must be balanced with the help of Pot R 1164 on the analogue board.  
To do that select voice test in the service mode and adjust with multimeter 5V at Pin 13 of CEM 3387.
- Individual outputs will now be tested in voice test mode 1-1, 2-2, 3-3, 4-4 and not any more in filter test.

For any further information or questions please contact us.

Best regards  
Waldorf Electronics GmbH

(Joachim Rehbein)

☎ D-(0) 26 36 / 76 32  
 📠 D-(0) 26 36 / 79 35  
 Neustraße 9  
 D - 53498 Waldorf

☎ D-(0) 26 36 / 8 02 05  
 📠 D-(0) 26 36 / 8 01 88  
 Hauptstraße 71  
 D - 53498 Waldorf

☎ D-(0) 26 36 / 8 02 94  
 📠 D-(0) 26 36 / 8 01 88  
 Hauptstraße 71  
 D - 53498 Waldorf

Waldorf Electronics GmbH • Neustr. 9 • D - 53498 Waldorf

T E C H N I C A L   I N F O   1 4

Digital board modification - MicroWave

**Error:** System crash when using the new software (V 2.0)  
 (a black bar or "ILL ..." appears in the display)

**What to do:** Terminate the address-pins A1 - A4 (pins 29 - 32)  
 on the CPU 68000 with a 470 Ohm R-net, 5 pins (all  
 connected to VCC) and a 330 Ohm R-net, 5 pins (all  
 connected to ground).

**Note:** First solder the R-nets together and then join it  
 directly to the CPU.

The modification should only be done by qualified  
 personell.

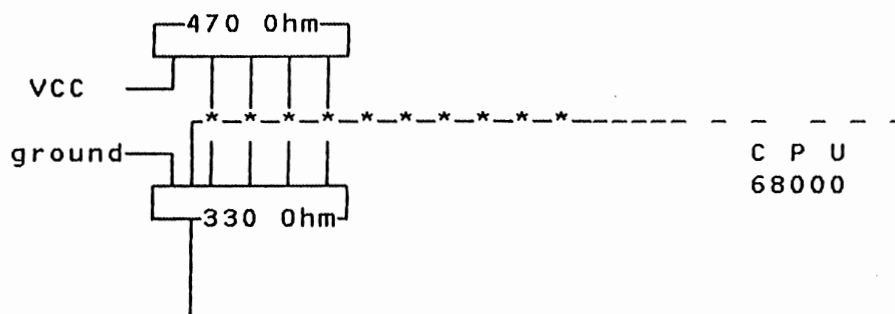



## Waldorf Electronics EMAIL services

Dear Customer !

To directly get in touch with you, Waldorf Electronics now provides world-wide email services:

### Hotline

(info@waldorf-gmbh.de)

Whatever question or problem you have, simply send us a mail. We will try to help you as fast as possible.

### Archive Server

(archive-server@waldorf-gmbh.de)

You're looking for sounds, tools or documentation ? Our archive probably has everything you need. You can retrieve files by sending mail to our automated server.

### User Forum

(user-forum@waldorf-gmbh.de)

Do you like to contact other Waldorf customers to get hints or to discuss wishes, features, problems... ? Join our mailing list and get in touch with Waldorf customers all over the world.

### How to do ?

What you need is a computer (you probably already have one), a modem, a piece of freely available software and access to the Internet or to any mailbox system, providing at least email service and a link to the Internet.

### What else is it good for ?

The Internet is a world-wide network with probably millions of users. It provides a lot of services, such as archive-servers with gigabytes of freely available software, an electronic news system organized in groups, incl. music-related ones, information retrieval systems, and last but not least electronic mail.

---

### Who offers Internet access ?

We can't tell you about all possibilities. Here are just a few network organisations offering access to the world-wide Internet. In case you live in a country not listed here, please contact us, or ask someone at the next university.

### Argentina:

ARNET  
Jorge Marcelo Amodio  
UNDP Project ARG-86-026  
Ministerio de Relaciones Exteriores y Culto  
Reconquista 1088 1er. Piso - Informatica  
(1003) Capital Federal  
Buenos Aires, ARGENTINA  
Phone: +541 313 8082

### Australia:

AARNet  
Geoff Huston  
GPO Box 1142  
Canberra ACT 2601  
AUSTRALIA  
Phone: +61 6 249 3385

### Austria:

EUNET-AT  
Dr. Michael Haberler  
EUnet EDV Dienstleistungs GmbH  
Schottenring 33  
A-1010 Vienna, AUSTRIA  
Phone: +43 1 3174969

### Belgium:

EUnet-Belgium  
Jean Huens  
Celetijnenlaan 200A  
B-3001 Leuven  
BELGIUM  
Phone: +32 16 201015

### Brazil:

AlterNex  
Carlos A. Afonso  
Rua Vicente de Souza, 29  
Rio de Janeiro, RJ 22251-070  
BRAZIL  
Phone: +55 21 286 0348  
Fax: +55 21 286 0541

### Bulgaria:

BCNET  
Daniel Kalchev  
Digital Systems Co.  
Neofit Bozveli 6  
Varna - 9000, BULGARIA  
Phone: +359 52 259135

### Canada:

CA\*NET  
Fax: +1 416 978 6620  
(no other information available)

### Chile:

REUNA  
Jose M. Piquer  
Depto. Ciencias de la Computacion  
Universidad de Chile  
Blanco Encalada 2120  
Casilla 2777  
Santiago  
CHILE  
Phone: +56 2 689 27 36

### Costa Rica:

CRNet  
Guy F. de Teramond  
Unidad de Redes  
Universidad de Costa Rica  
San Jose, COSTA RICA  
Phone: +506 25 29 11

### Czech Republic:

CZnet  
Pavel Rosendorf  
Prague Institute of Chemical Technology  
Computing Centre  
Technicka 3  
Prague 6  
166 28  
CZECH REPUBLICA  
Phone: +42 2 332 3242

### Denmark:

DENet  
Steen Linden  
UNI-C - Danish Computing Centre  
DTH Building 305  
DK-2800 Lyngby  
DENMARK  
Phone: +45 45 93 83 55

### Egypt:

EUN  
Prof. M.A.R. Ghonaimy  
FRCU Computer Center  
Supreme Council of Universities  
Cairo University  
Giza, EGYPT  
Phone: +202 735 405

### Finland:

EUnet Finland  
Kuusikallionkuja 3 B 25  
FI-02210 Espoo  
FINLAND  
Phone: +358 0 400 2060

### France & Africa:

RIO  
Pascal Renaud  
213, Rue Lafayette  
75 480 PARIS Cedex 10  
FRANCE  
Phone: +33 1 48 03 77 77

### Germany:

EUnet Deutschland GmbH  
Emil-Figge-Strasse 80  
D-4800 Dortmund 50  
GERMANY  
Phone: +49 231 972 00

### Hong Kong

Hong Kong Supernet  
Bob Coggeshall  
Supernet Project  
c/o Department of Computer Science  
Hong Kong University of Science and  
Technology  
Clear Water Bay, Kowloon  
HONG KONG  
Phone: +852 358 6994

### Ireland:

IEunet  
Gordon Rickerby  
IEunet Ltd.  
O'Reilly Institute  
Trinity College  
Dublin 2 IRELAND  
Phone: +353 1 6719361

**Israel:**

ILAN  
Hank Nussbacher  
Computer Center  
Tel Aviv University  
Ramat Aviv  
ISRAEL  
Phone: +972 3 640 83 09

**Italy:**

GARR  
c/o CNUCE - Istituto del CNR  
Via S. Maria, 36  
I-56126 PISA  
ITALY  
Phone: +39 50 593360

**Japan:**

IJ Internet  
Internet Initiative Japan, Inc.  
Hoshiagaoka Bldg.  
2-11-2 Nagata-cho  
Chiyoda-ku, Tokyo 100  
JAPAN  
Phone: +81 3 5380 3781

**New Zealand:**

Tuia  
Dr. Neil James  
University of Otago  
P.O. Box 56  
Dunedin  
NEW ZEALAND  
Phone: +64 3 479 8594

**Norway:**

EUnet Norway  
Arne Asplem  
Gaustadellen 21  
N-0371 Oslo  
NORWAY  
Phone: +47 229 58 327

**People's Republic of China:**

CANET  
Tian Bai Qian  
CANET Chinese Academic Network  
c/o ICA  
P.O. Box 2418-26  
Che-Dao-Gou Street  
Beijing  
PEOPLE'S REPUBLIC OF CHINA  
Phone: +86 841 3654

**Poland:**

ByTNet  
Jerzy Zenkiewicz  
Nicholas Copernicus University  
Computing Center  
ul. Chopina 12/18  
87-100 Torun  
POLAND  
Phone: +48 56 244 29

**Portugal:**

EUnet Portugal  
Jose Legatheaux Martins  
EUnet-PT  
c/o PUUG - Portuguese Unix User Group  
Av. 24 de Julho 134-70  
1300 Lisbon  
PORTUGAL  
Phone: +351 1 395 06 42

**Korea:**

KREN  
Eunkyung Kim  
Seoul National University Computing Center  
San56-1, Shillim-dong, Kwanak-gu  
Seoul 151-742, KOREA  
Phone: +82 2 880 5365

**Russia:**

Relcom  
Dmitry V. Burkov  
123060  
Moscow, ul. Raspletina, d.4, k.1  
RUSSIA  
Phone: +7 095 198 37 96

**Slovakia:**

EUnet-SK  
Gejza Buechler  
c/o Comenius University  
Faculty of Mathematics and Physics  
Computing Center  
Mlynska dolina  
842 15 Bratislava  
SLOVAKIA

**South Africa:**

UNINET-ZA  
UNINET Office  
P.O. Box 2600  
Pretoria  
0001  
SOUTH AFRICA  
Phone: +27 12 841 3542

**Spain:**

EUnetES  
Juan A. Esteban  
Goya Servicios Telematicos SA  
Clara del Rey 8, 1-7  
E-28002 Madrid  
SPAIN  
Phone: +34 1 413 48 56

**Sweden:**

SUNET  
Hans Wallberg  
SUNET/UMDAC  
S-901 87 Umea  
SWEDEN  
Phone: +46 90 16 56 45

**Switzerland:**

EUnet/CH  
Simon Poole  
Zweierstrasse 35  
CH-8004 Zurich  
SWITZERLAND  
Phone: +41 1 291 45 80

**Taiwan:**

TANet  
Chen Wen-Sung  
Computer Center, Ministry of Education  
Fl. 12, No. 106  
Section 2, Hoping East Rd.  
Taipei, TAIWAN  
Phone: +886 2 73 77 011

**Thailand:**

THAINET  
Dr. Yunyong Teng-amnuay  
Centers of Academic Resources  
Chulalongkorn University  
Phyathai Rd., Bangkok 10330  
THAILAND  
Phone: +66 2 218 2925

**The Netherlands:**

SURFnet  
SURFnet User Support  
P.O. Box 19035  
NL-3501 DA Utrecht  
THE NETHERLANDS  
Phone: +31 30 31 02 90

**Turkey:**

TUVAKA  
Esra Delen  
Ege University, Bilgisayar Arastirma ve  
Uygulama Merkezi, 35100  
Bornova, Izmir, TURKEY  
Phone: +90 51 881080 278

**United Kingdom:**

JANET  
JANET Liaison Desk  
Joint Network Team  
c/o Rutherford Appleton Laboratory  
Chilton  
Didcot  
Oxfordshire OX11 0QX  
UNITED KINGDOM  
Phone: +44 235 44 5517

**United States:**

Internet - Global Network of Networks  
InterNIC Information Services  
c/o General Atomics  
P.O. Box 85608  
San Diego, CA 92186-9784  
USA  
Phone: +1 619 455 4600  
+1 800 444 4345 (US only)

---

**GLOBAL Networks:****CompuServe**

Internet Postmaster  
CompuServe Incorporated  
5000 Arlington Centre Blvd  
Columbus, OH 43220  
USA  
Phone: +1 614 457 0348

**FidoNet**

Tim Pozar  
Late Night Software  
674 Vermont Street  
San Francisco, CA 94107  
USA  
Phone: +1 415 695 7727

NOTIZEN - NOTES

NOTIZEN - NOTES

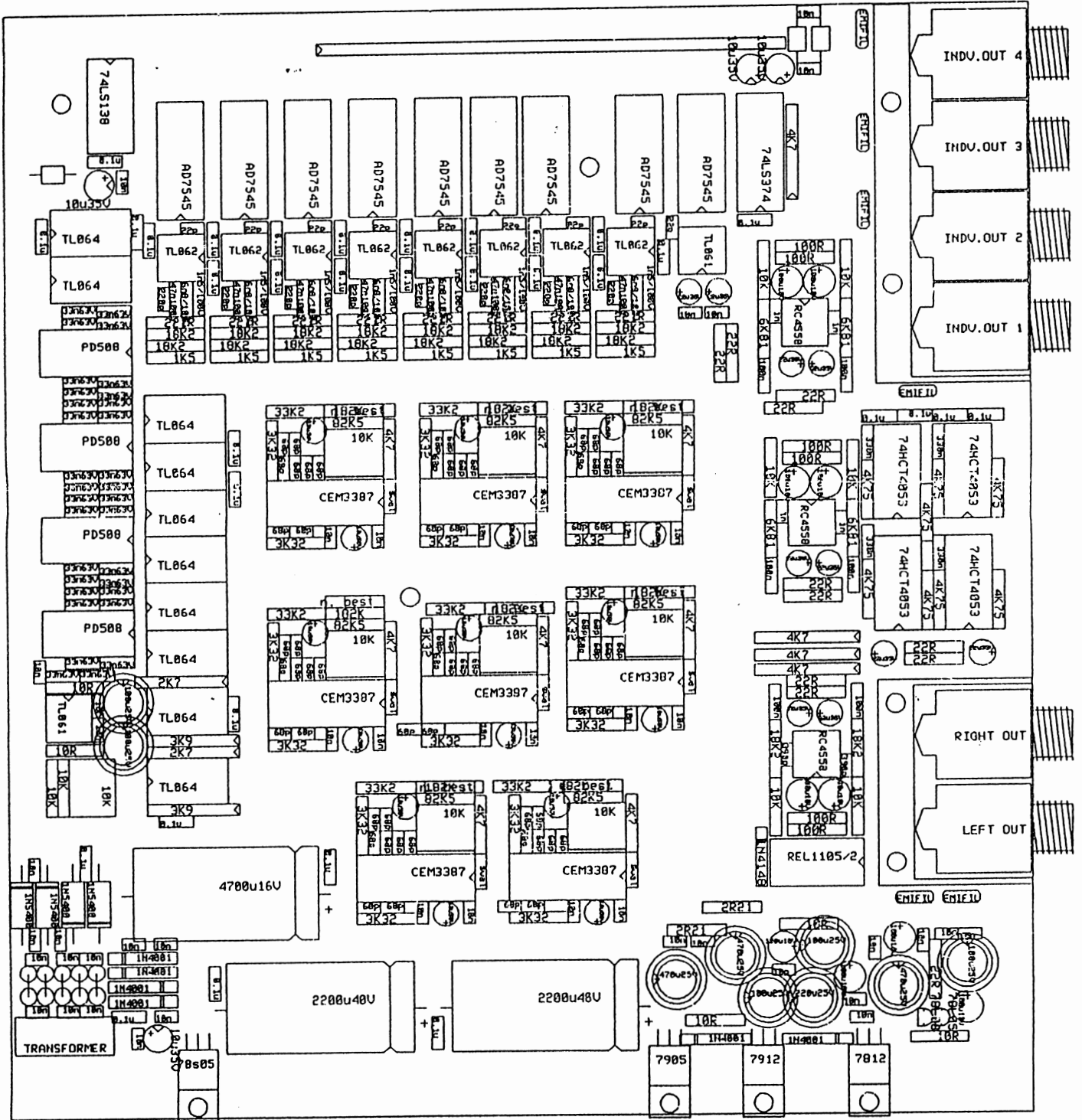

425 # <



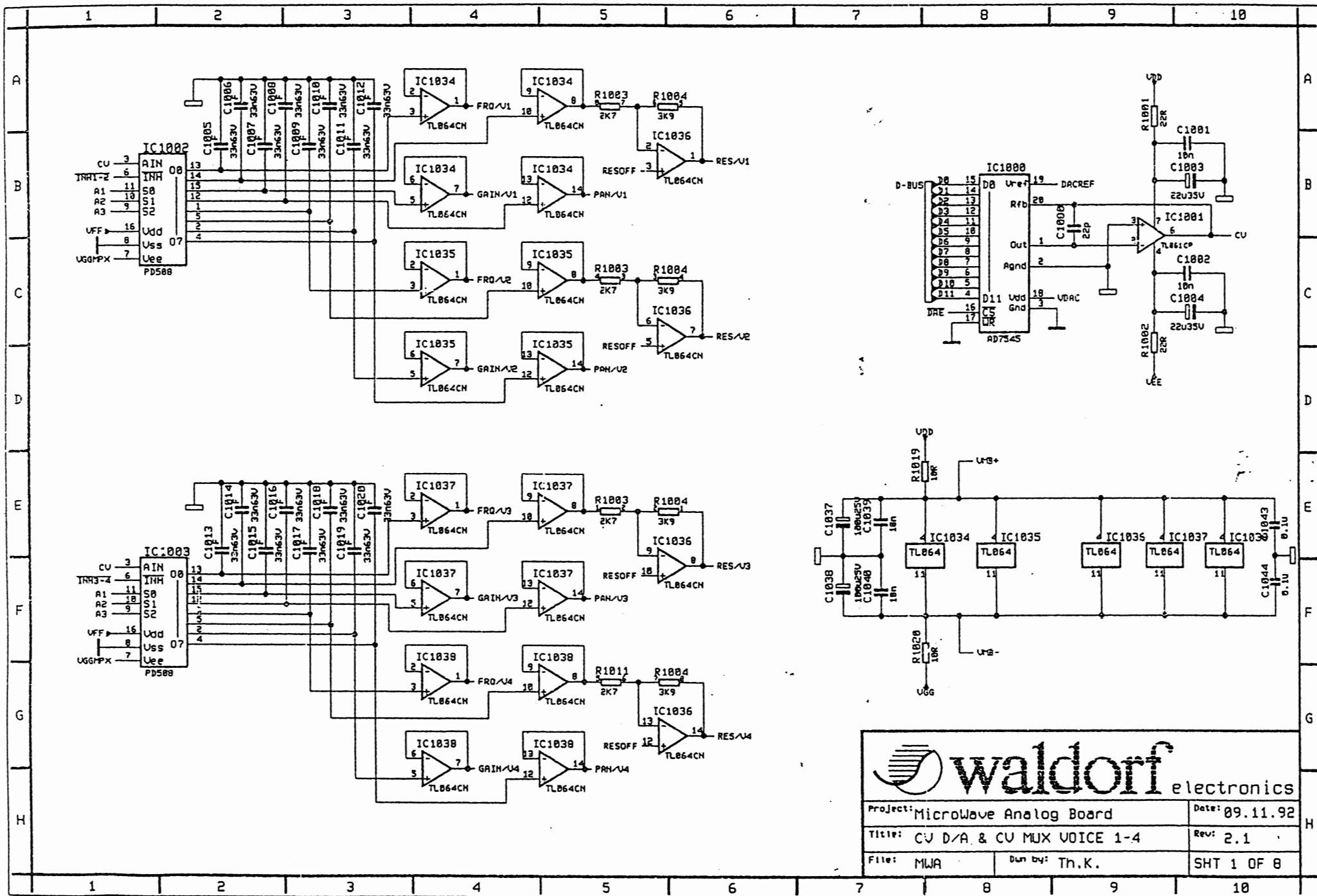

Project: MicroWave Analog Board		Date: 09.11.92	
Title: CU D/A & CU MUX VOICE 1-4		Rev: 2.1	
File: MWA	Des by: Th.K.	SHT 1 OF 8	

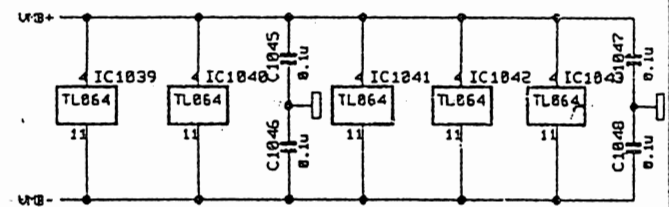
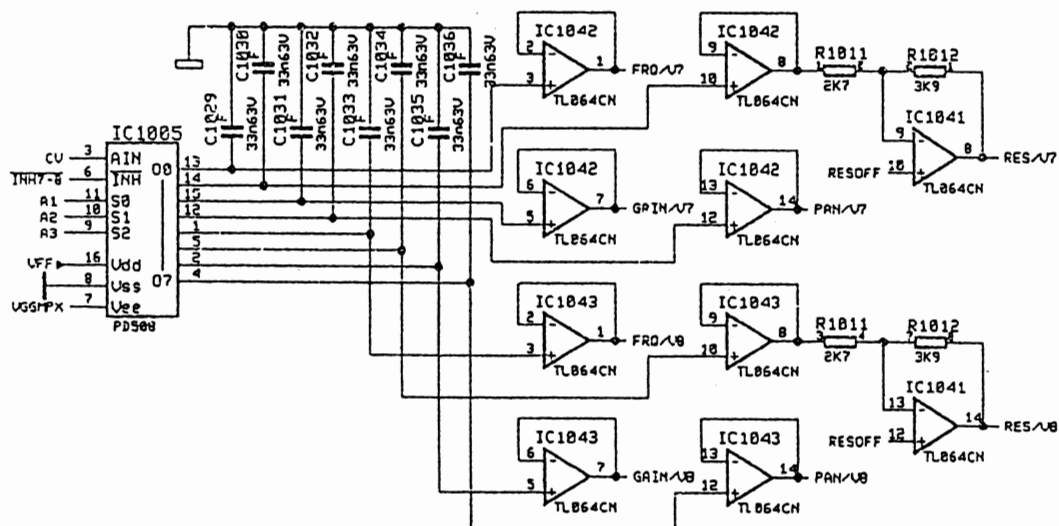
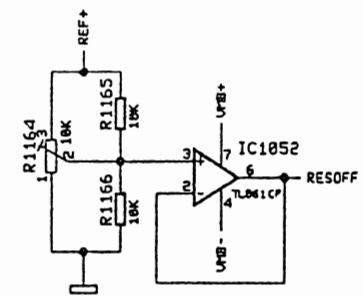
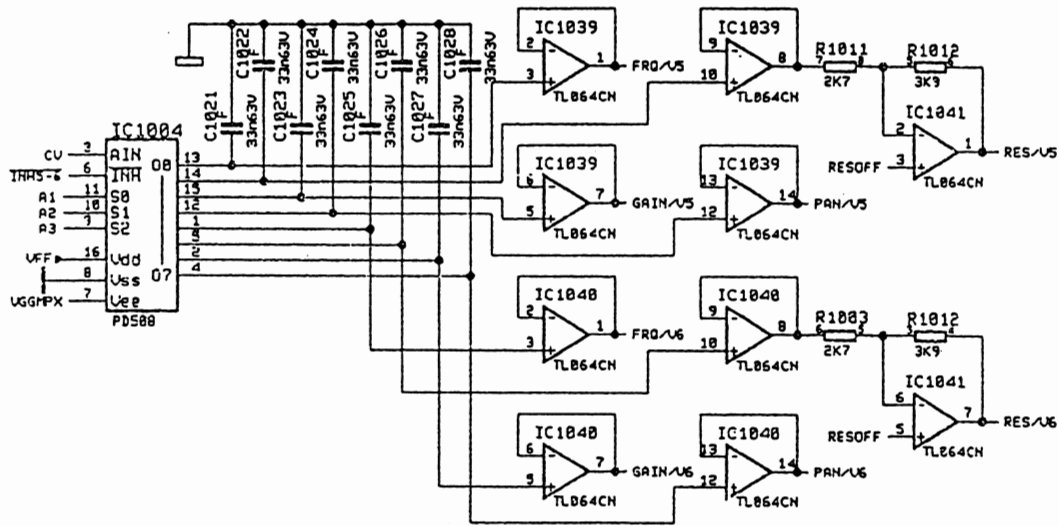

**waldorf** electronics

Project: MicroWave Analog Board		Date: 09.11.92
Title: CV MUX VOICE 5-8		Rev: 2.1
File: MWA	Drawn by: Th.K.	SHT 2 OF 8



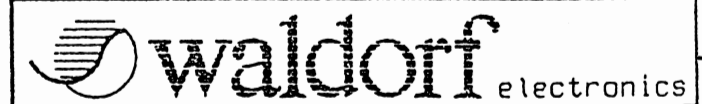
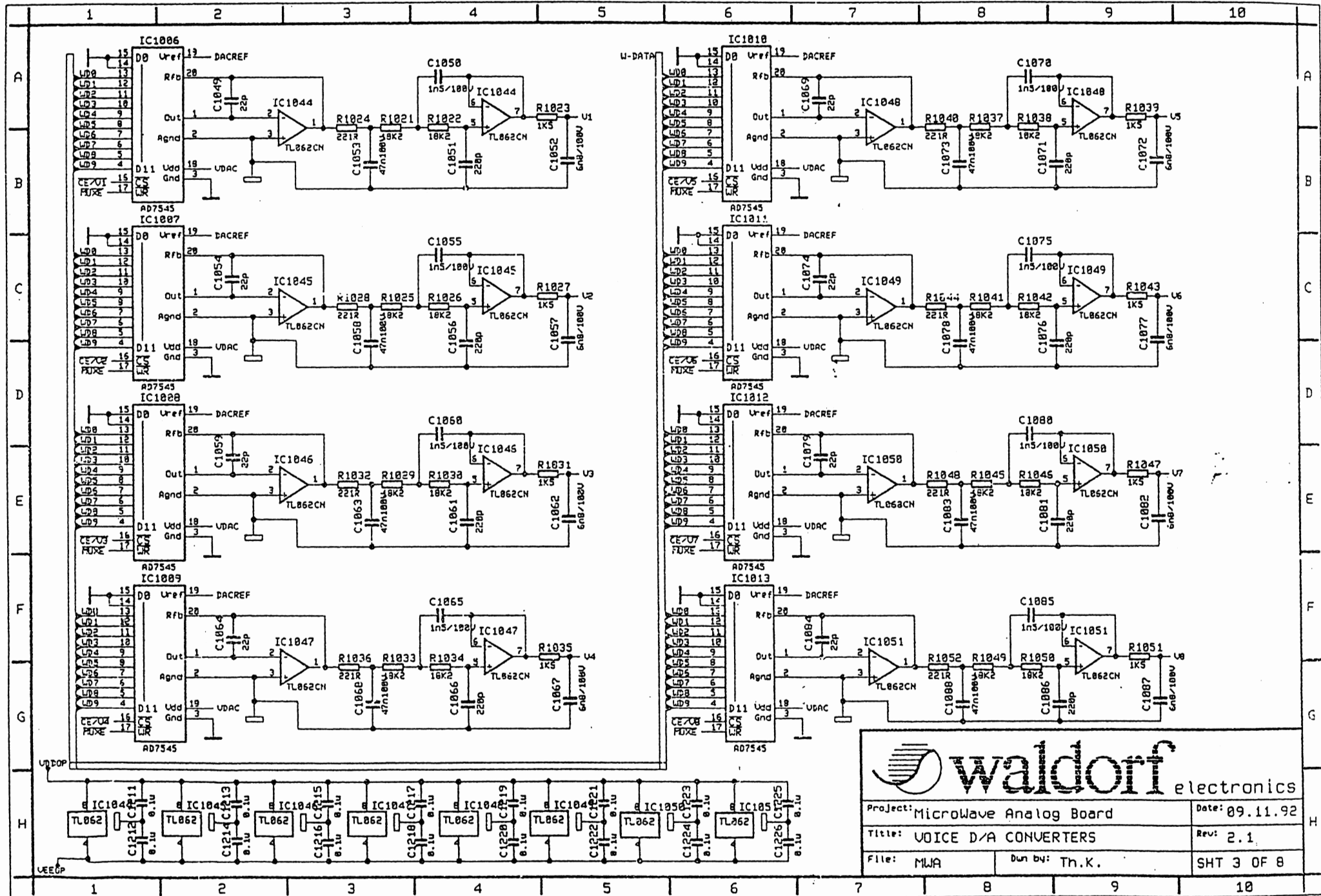

Project: MicroWave Analog Board		Date: 09.11.92
Title: VOICE D/A CONVERTERS		Rev: 2.1
File: MWA	Dev by: Th.K.	SHT 3 OF 8

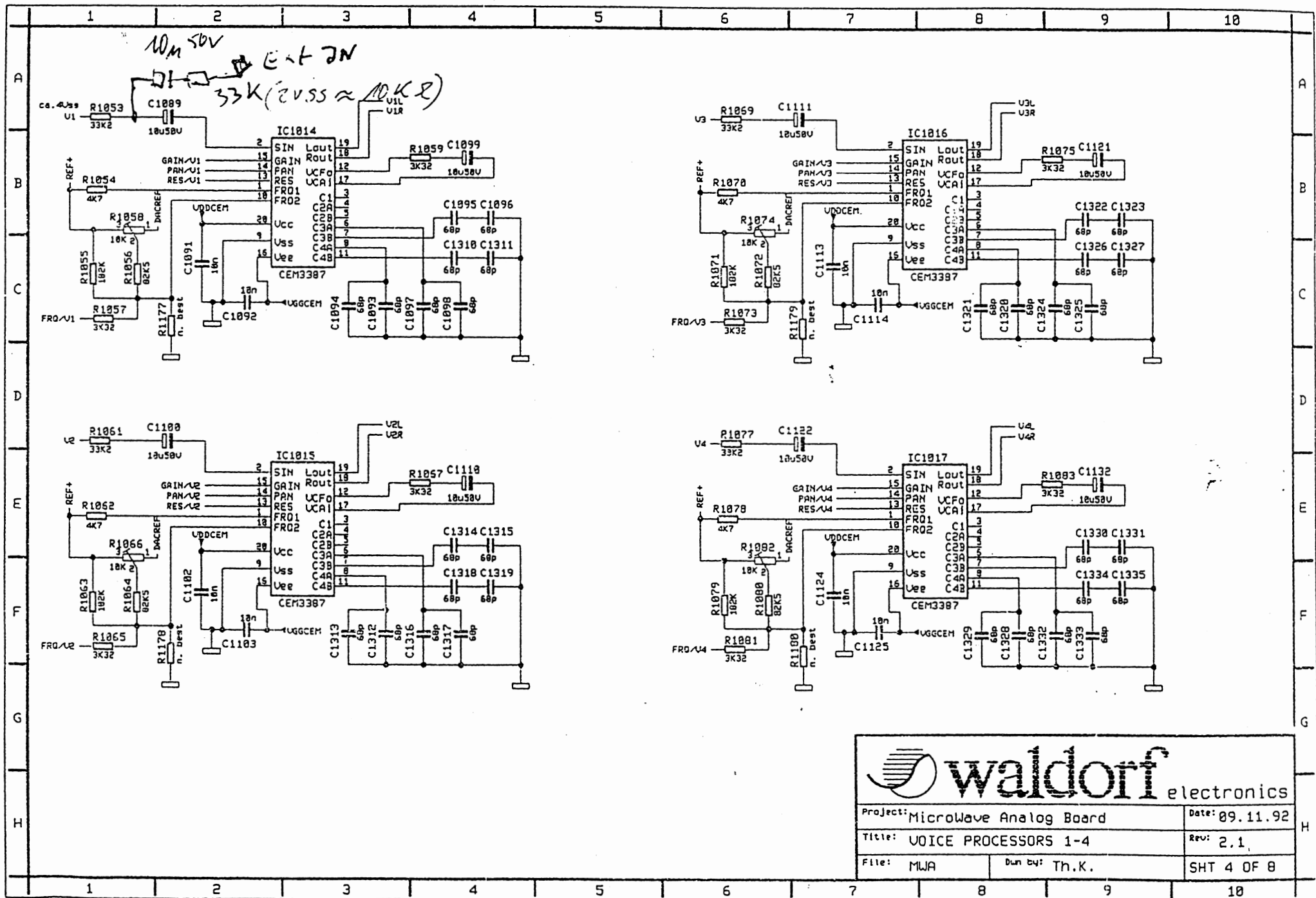

Project: MicroWave Analog Board		Date: 09.11.92
Title: VOICE PROCESSORS 1-4		Rev: 2.1
File: MWA	Drawn by: Th.K.	SHT 4 OF 8

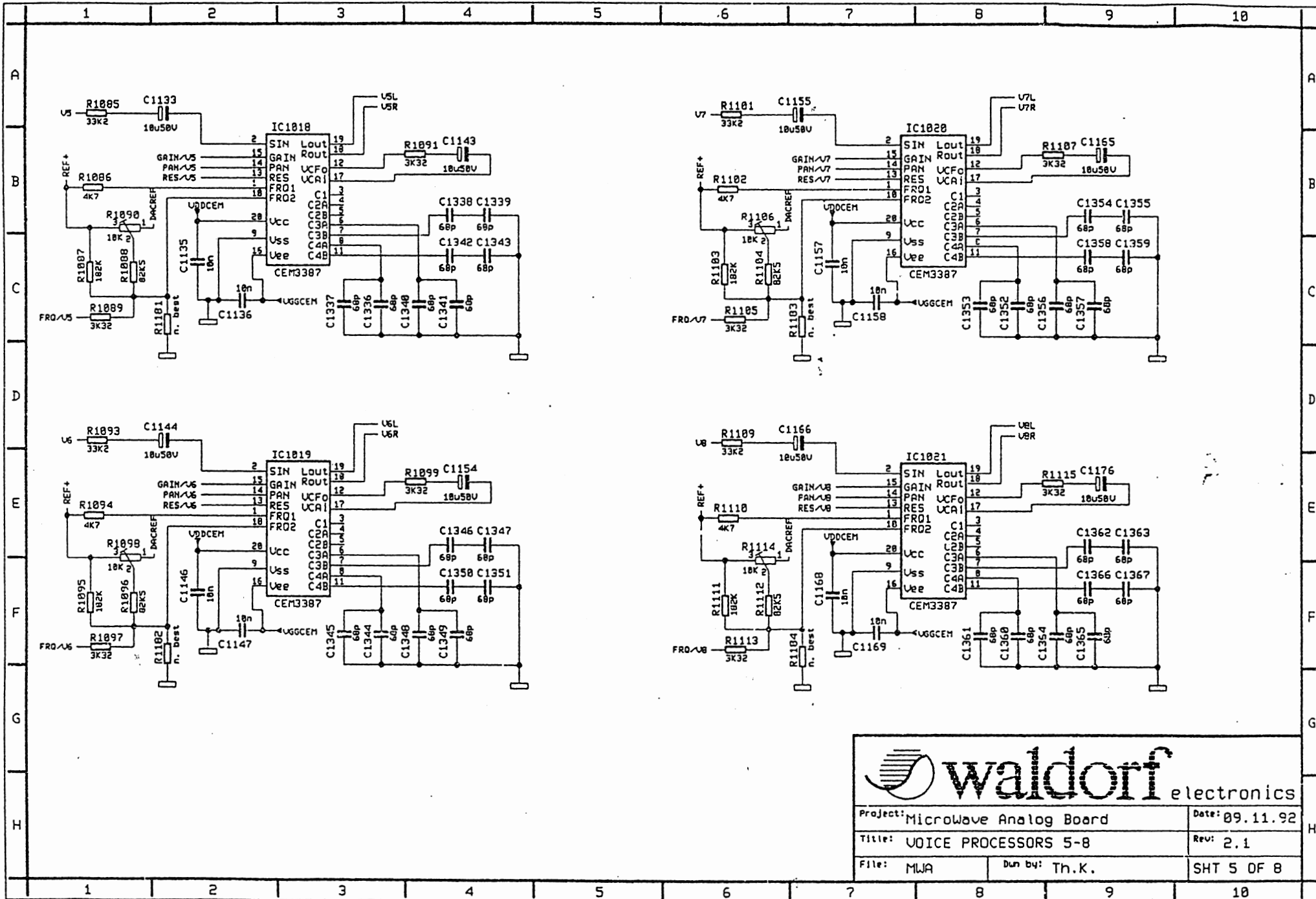

**waldorf** electronics

Project: MicroWave Analog Board		Date: 09.11.92
Title: VOICE PROCESSORS 5-8		Rev: 2.1
File: MWA	Des by: Th.K.	SHT 5 OF 8

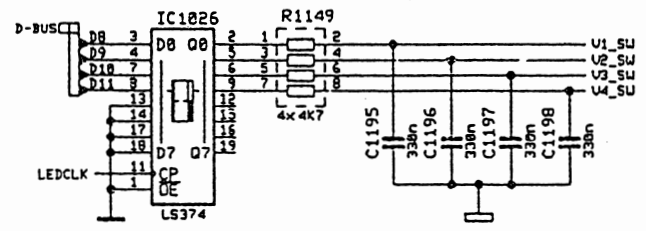
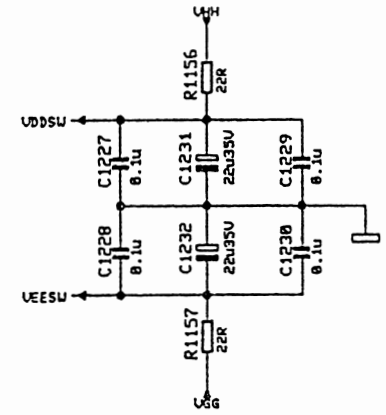
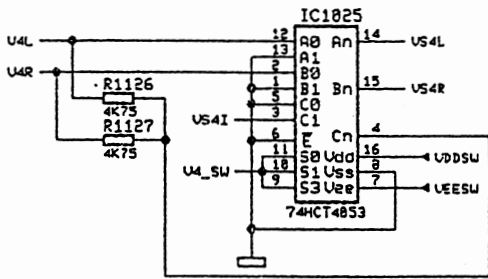
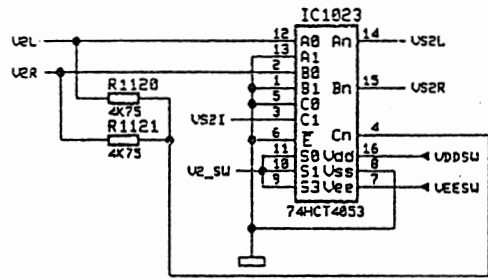
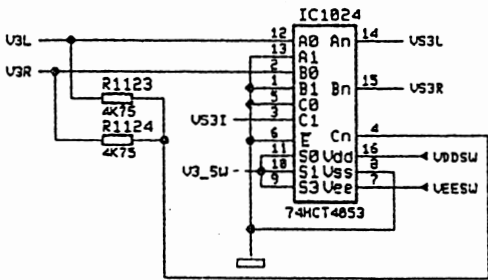
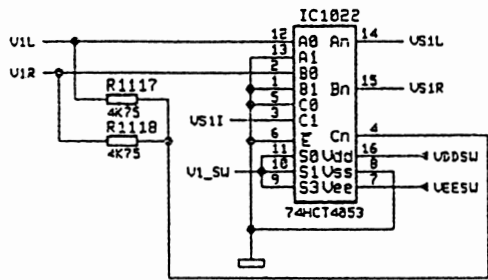

 waldorf electronics

Project: MicroWave Analog Board		Date: 09.11.92
Title: INDIVIDUAL OUTPUT SWITCHES		Rev: 2.1
File: MWA	Des by: Th.K.	SHT 6 OF 8

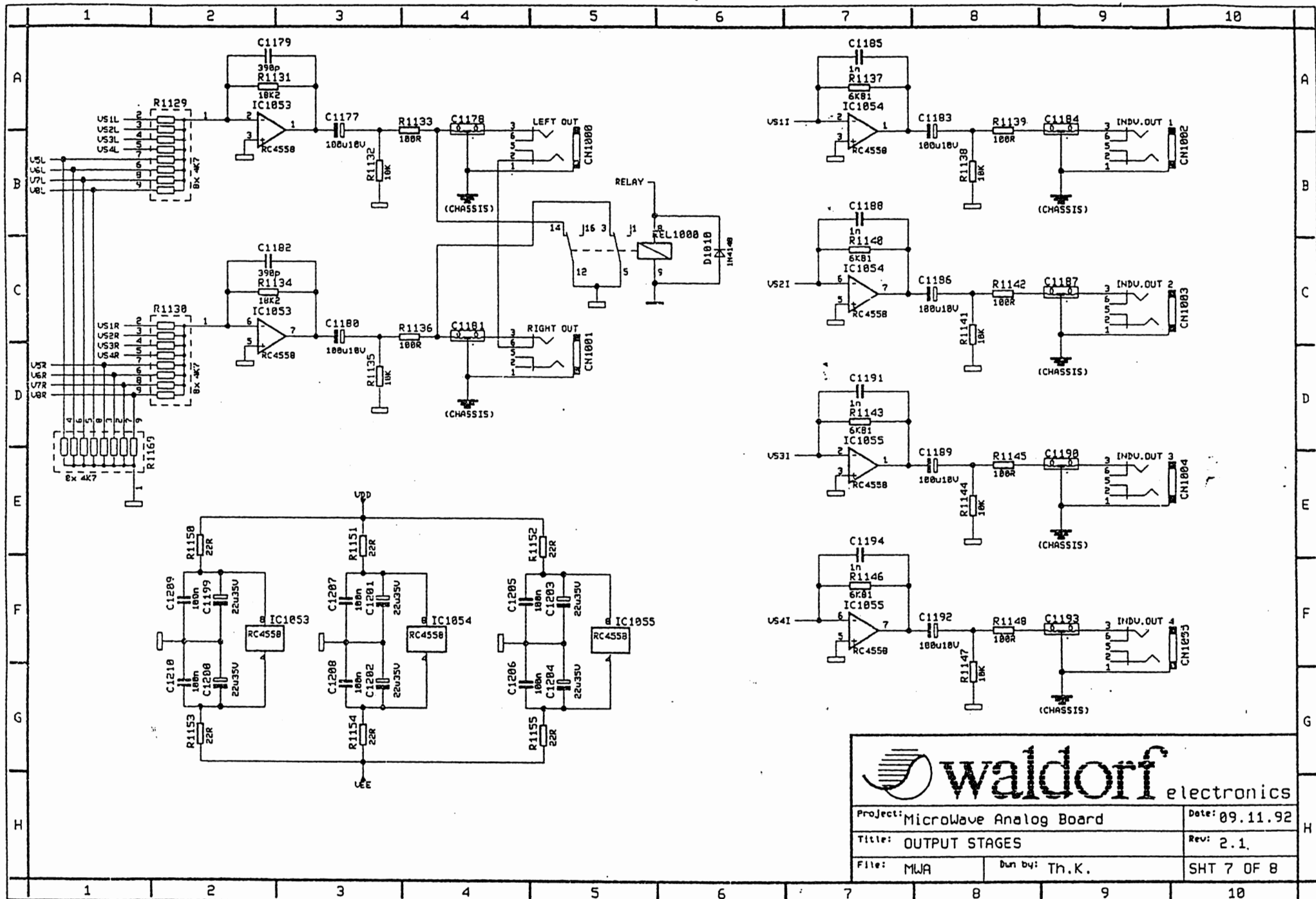

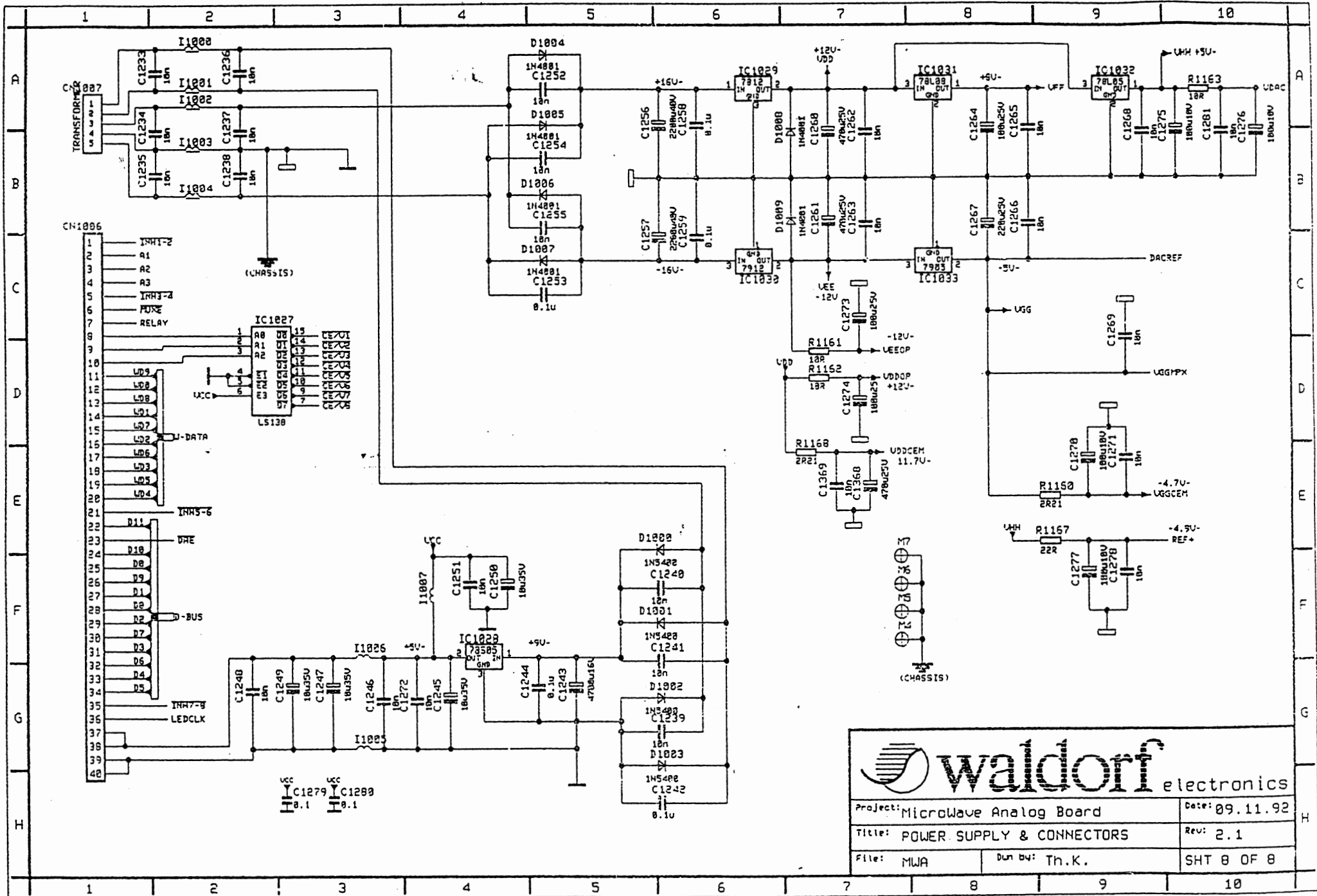

**waldorf** electronics

Project: MicroWave Analog Board		Date: 09.11.92	
Title: OUTPUT STAGES		Rev: 2.1.	
File: MWA	Des by: Th.K.	SHT 7 OF 8	

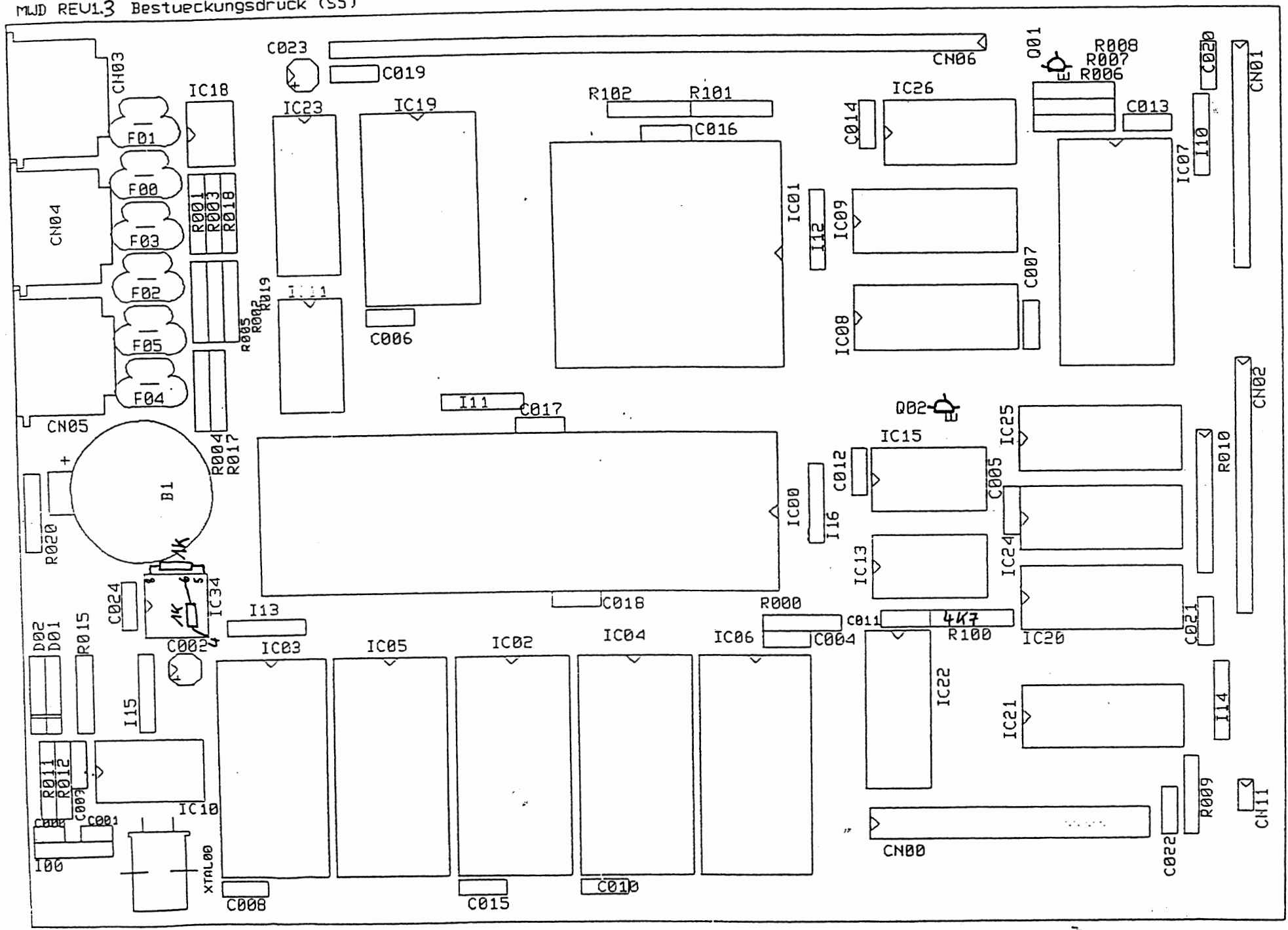

Project: MicroWave Analog Board		Date: 09.11.92
Title: POWER SUPPLY & CONNECTORS		Rev: 2.1
File: MWA	Des by: Th.K.	SHT 8 OF 8

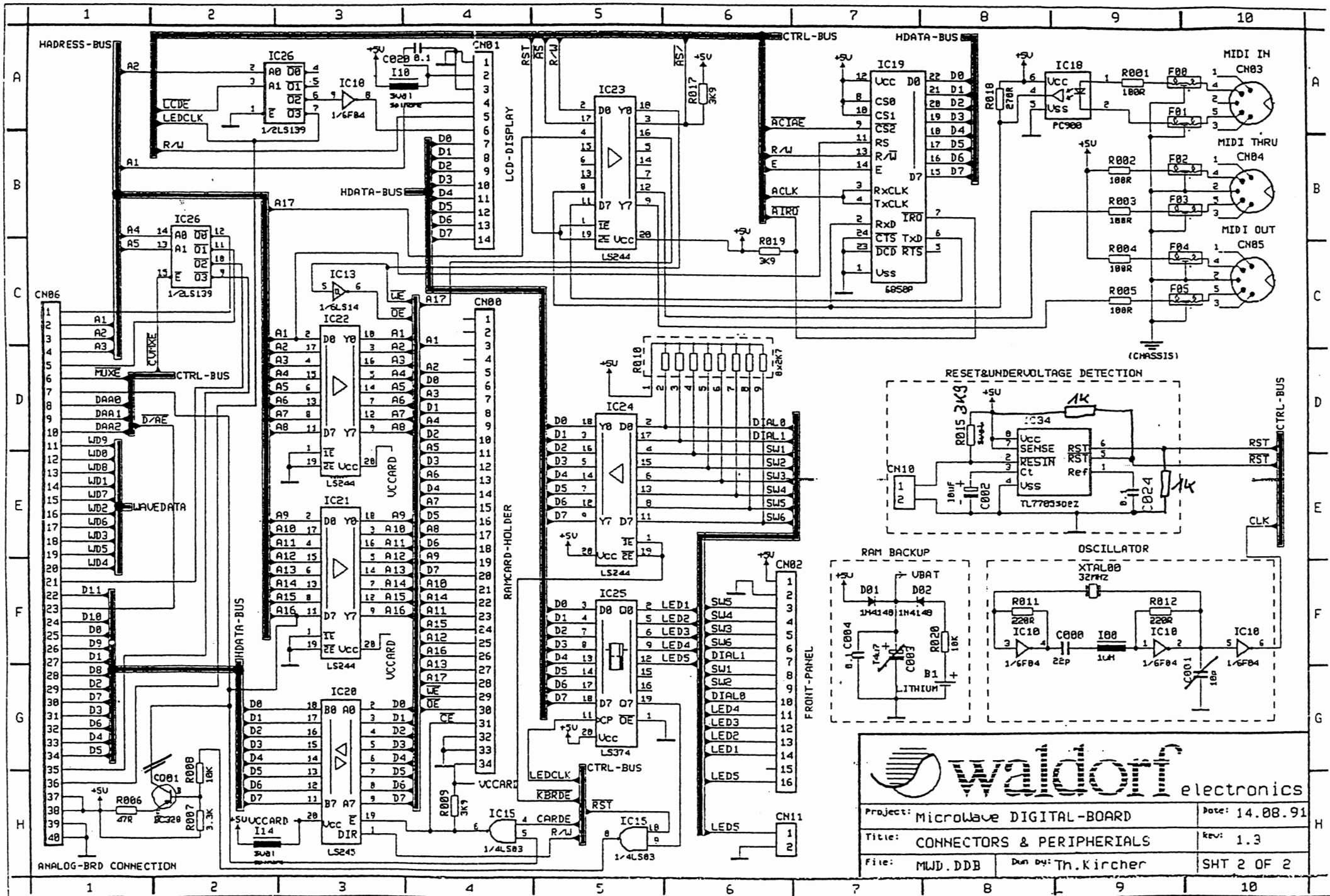



**Waldorf electronics**

Project: MicroWave DIGITAL-BOARD	Date: 14.08.91
Title: CONNECTORS & PERIPHERALS	Rev: 1.3
File: MWD.DDB	Drawn by: Th.Kircher
SHT 2 OF 2	



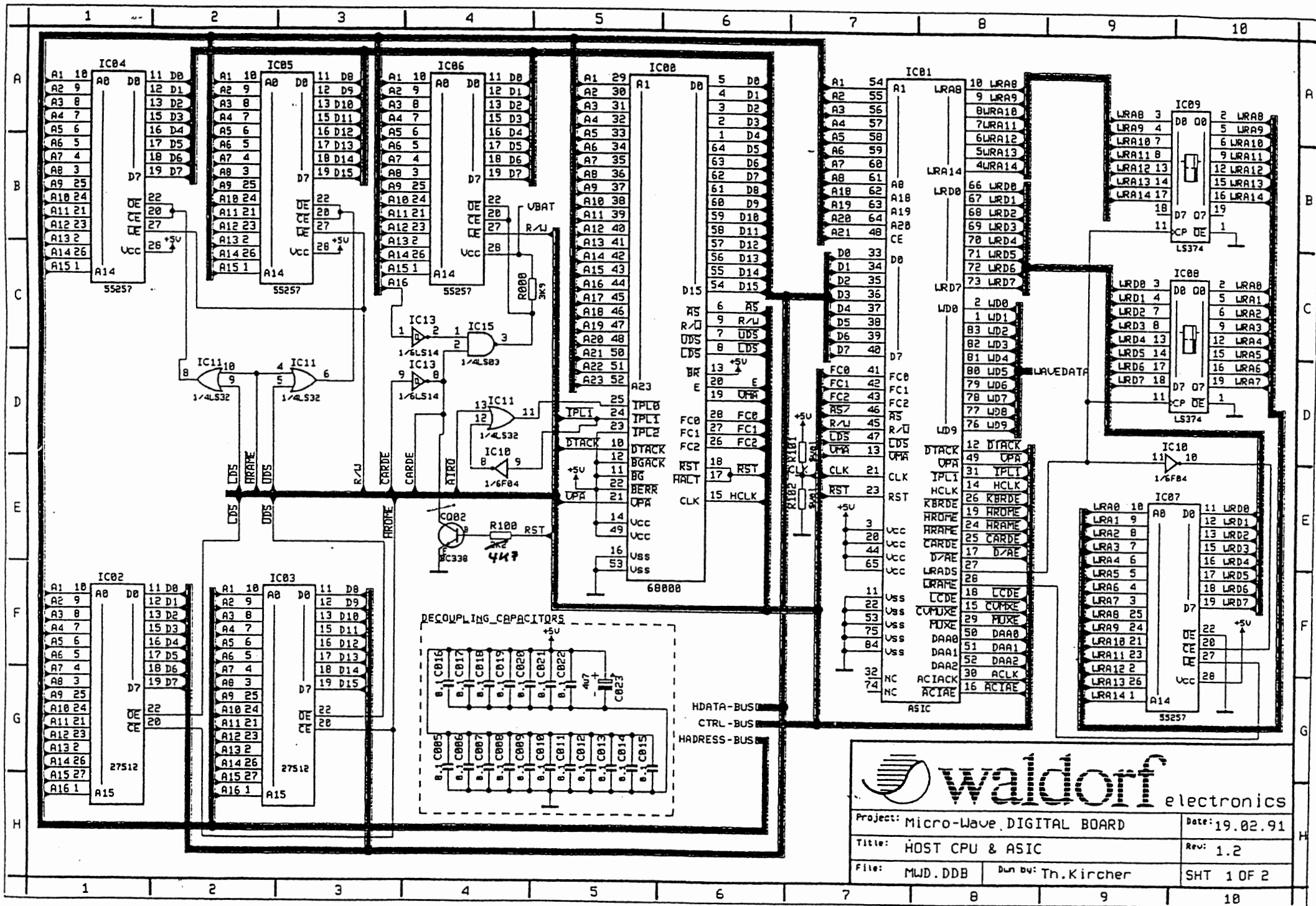

**waldorf** electronics

Project: Micro-Wave DIGITAL BOARD	Date: 19.02.91
Title: HOST CPU & ASIC	Rev: 1.2
File: MWD.DDB	Drawn by: Th.Kircher
SHT 1 OF 2	

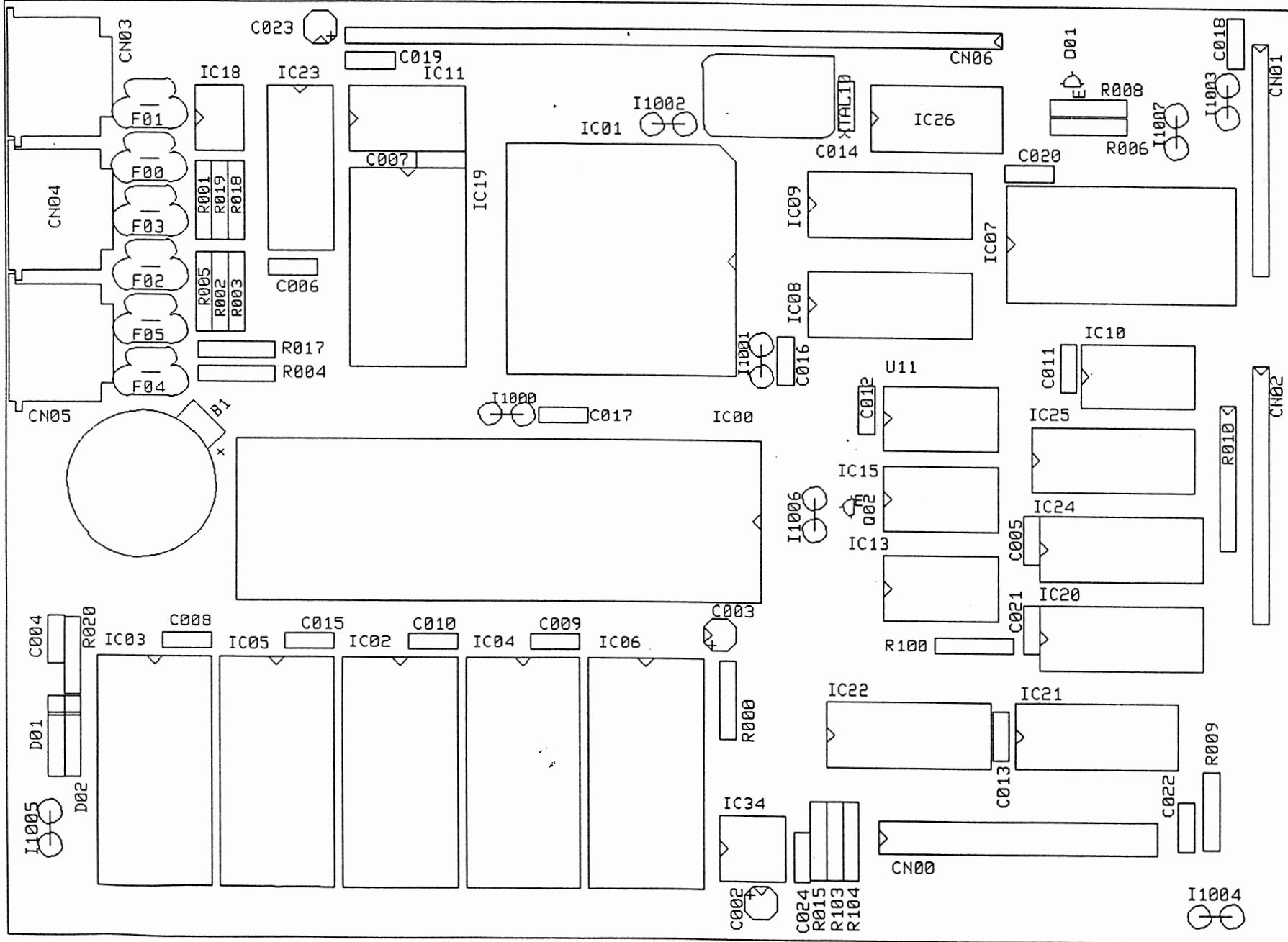

># 933...

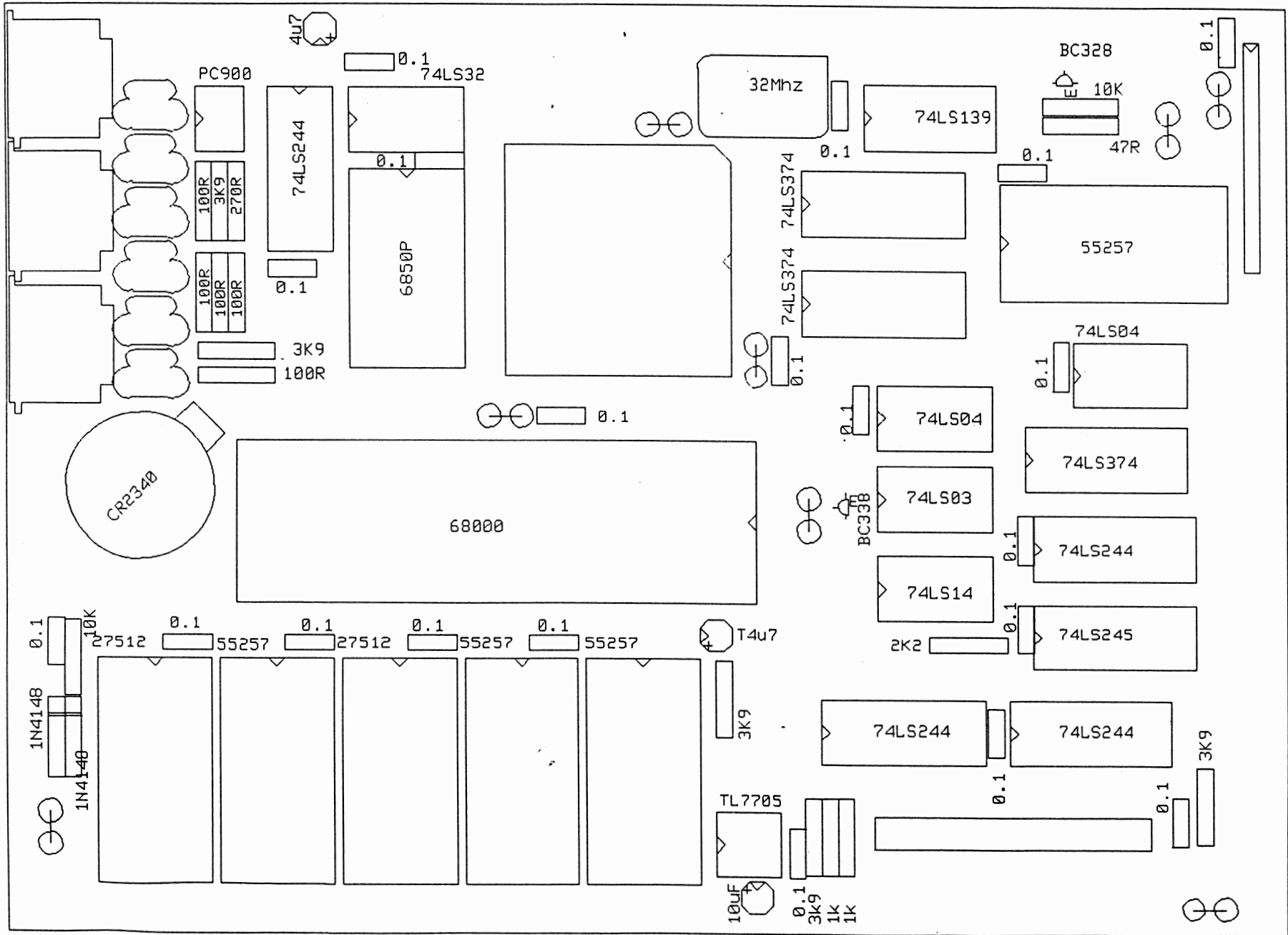



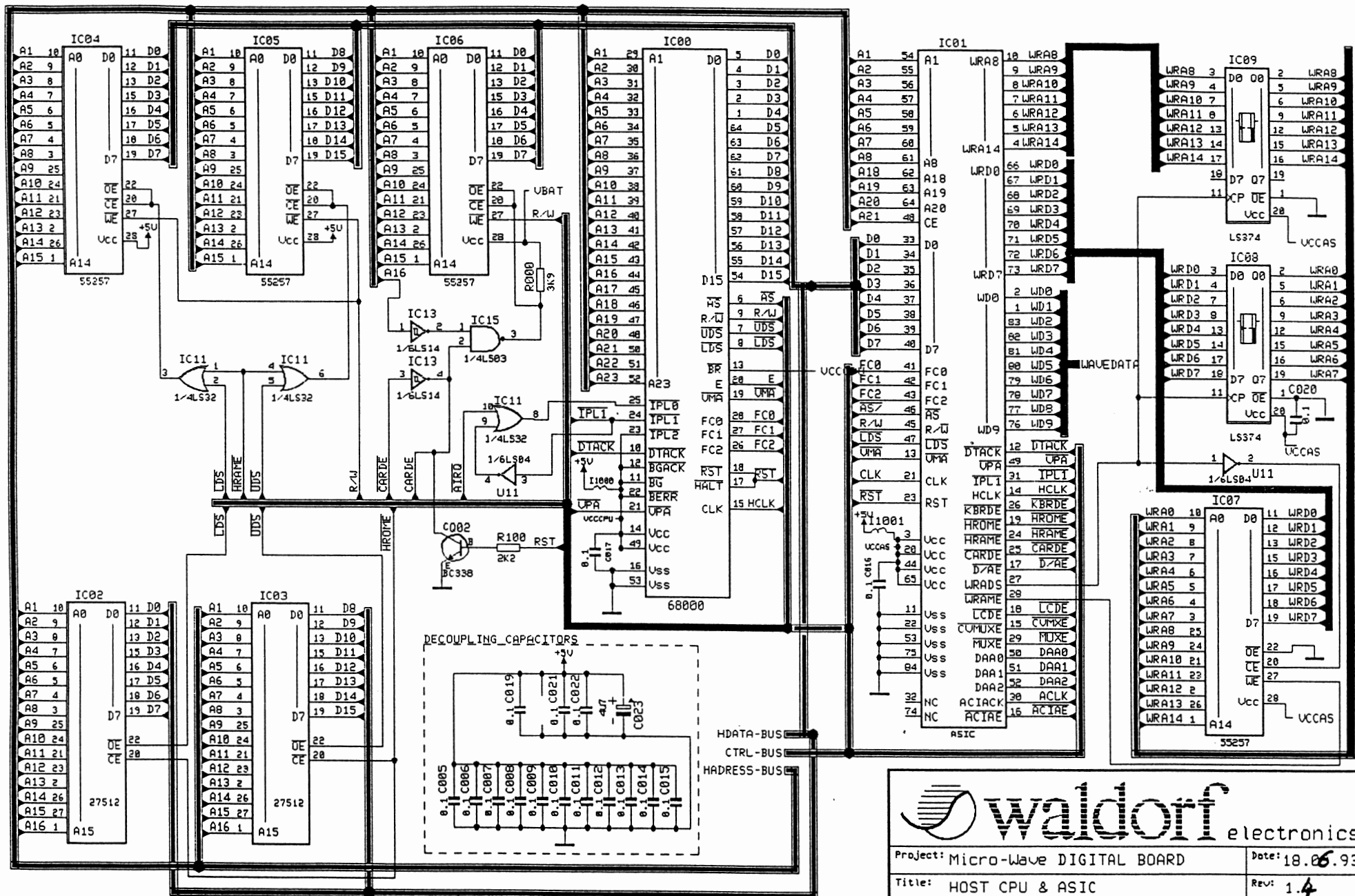

Project: Micro-Wave DIGITAL BOARD	Date: 18.06.93
Title: HOST CPU & ASIC	Rev: 1.4
File: MWD.DDB   Drawn by: Th.Kircher	SHT 1 OF 2

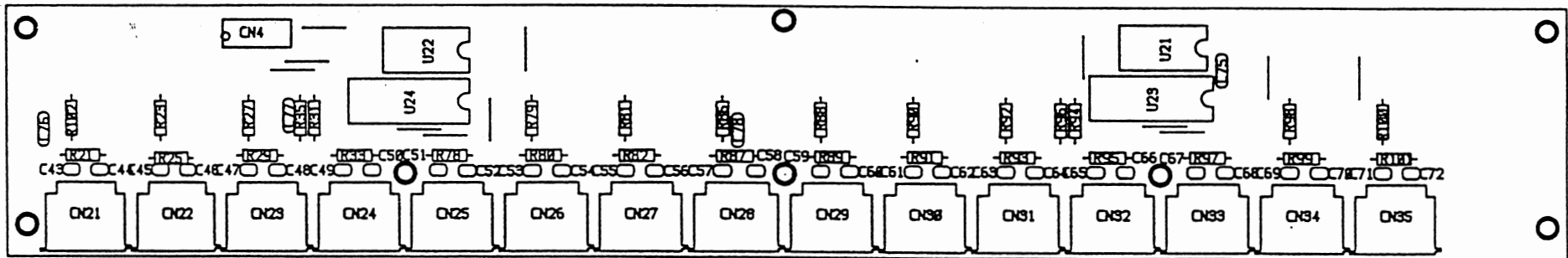

**Owaldorf** electronics

Project	MIDI BAY	Page Title	MIDI OUT PCB
Drawn by	Th. Kircher	Date	19.02.98
File	PHPBOUT	Rev	302 100 0301
		SHT	OF

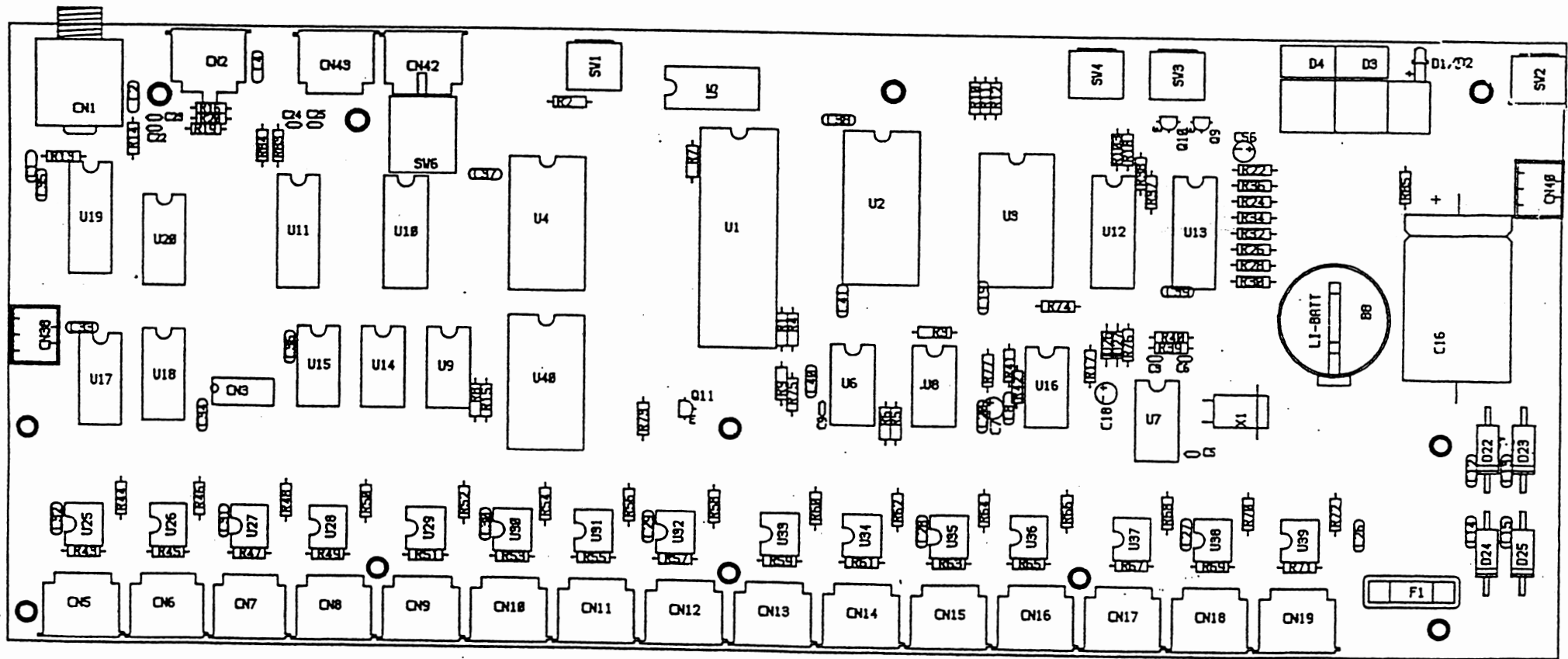

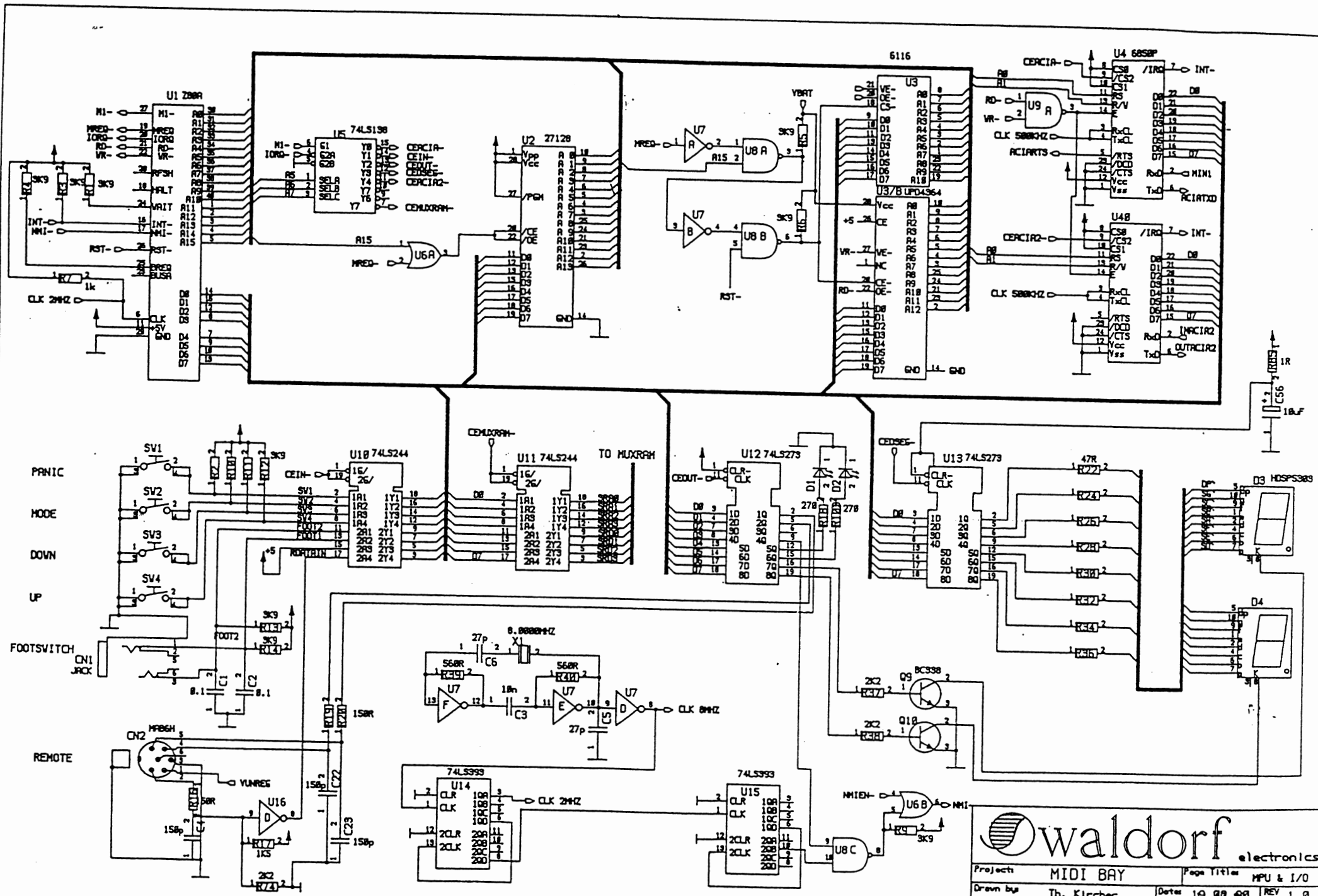



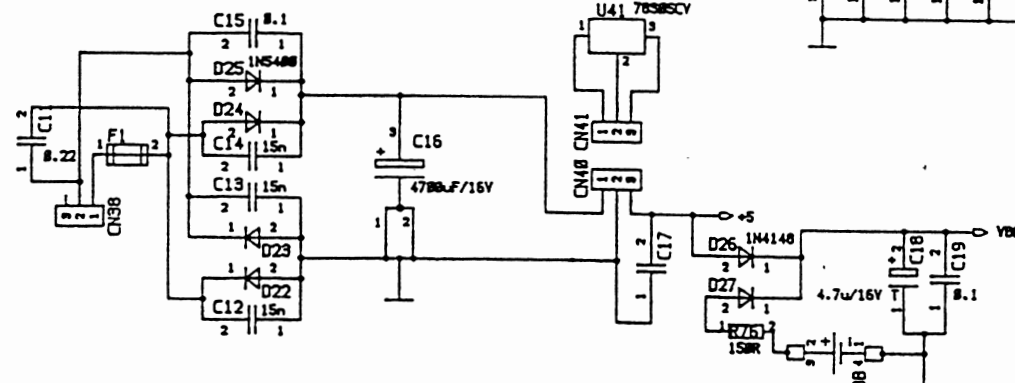
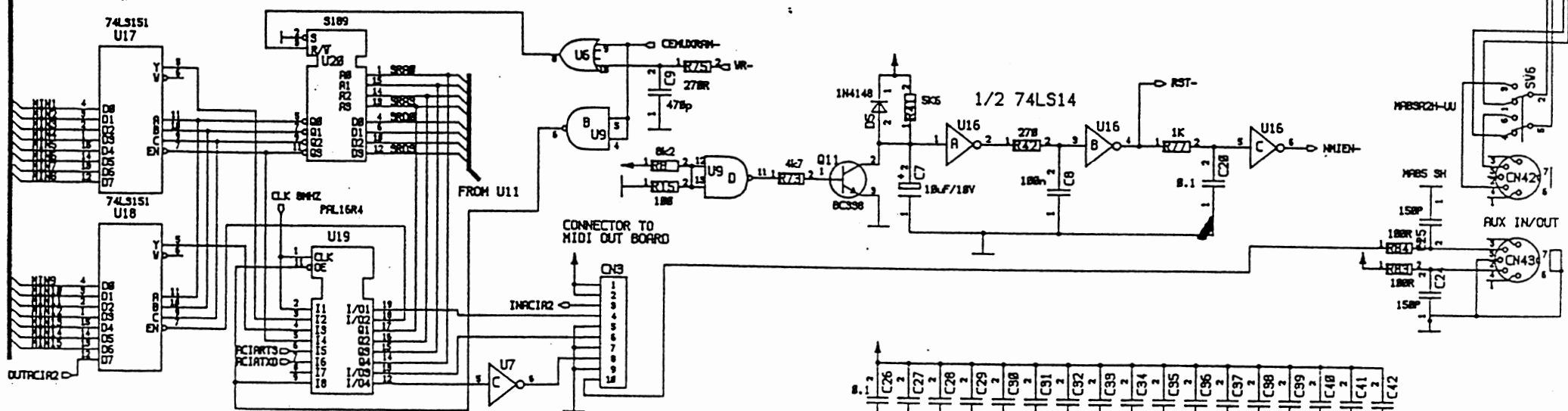
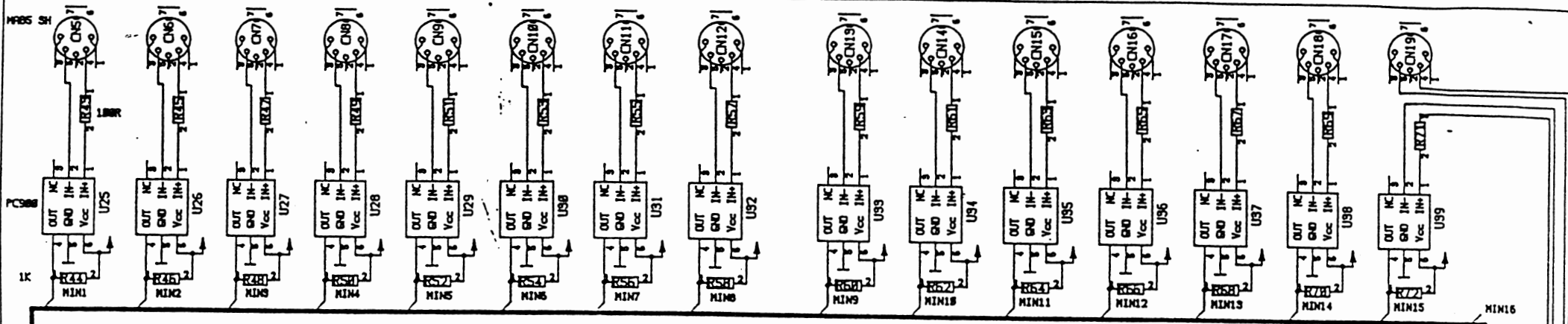

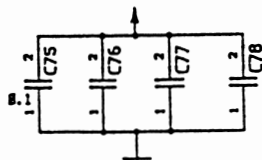
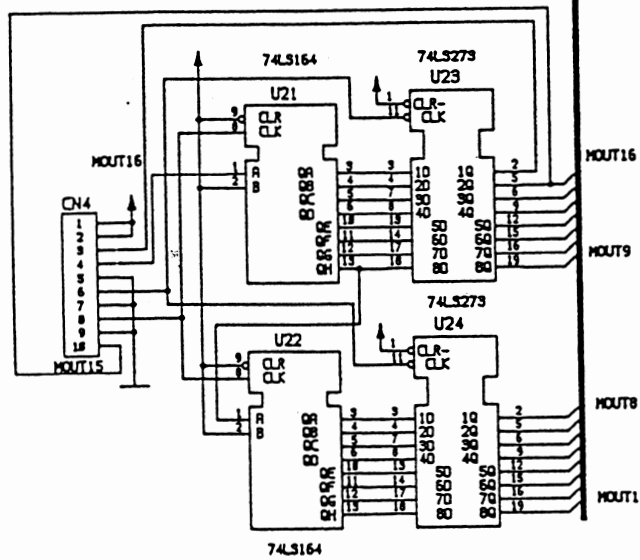
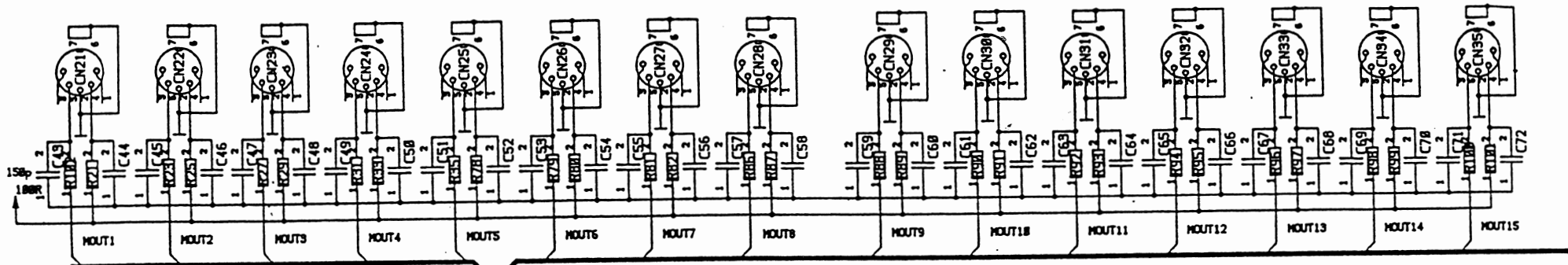

		Project MIDI BAY		Page 11 of 11	MIDI OUT PCB
		Drawn by Th. Kircher		Date 18.02.99	REV 1.0
File: PHPBOUT	Nr: 382 100 0301	SHT 3 OF 5			