

CPB

YAMAHA

C1

EC	1
-10C	2
TR	3
TR	4
E	5
22/3'	6
E	7
P8	8

C2

E	1
00	2
E	3
ENC	4
E	5
16'	6
E	7
8'	8

C3

E	1
51/3'	2
E	3
4'	4
E	5
2'	6
E	7
16'	8
E	9
P8'	10

TE • JK • DC Circuit Board & Wiring

HL
HR
E
FC
+15'
OUT
E

C 28942

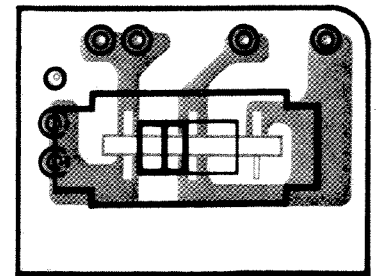
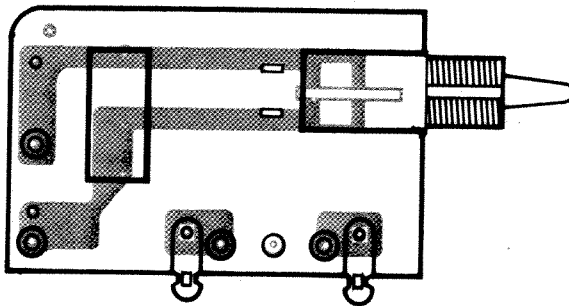
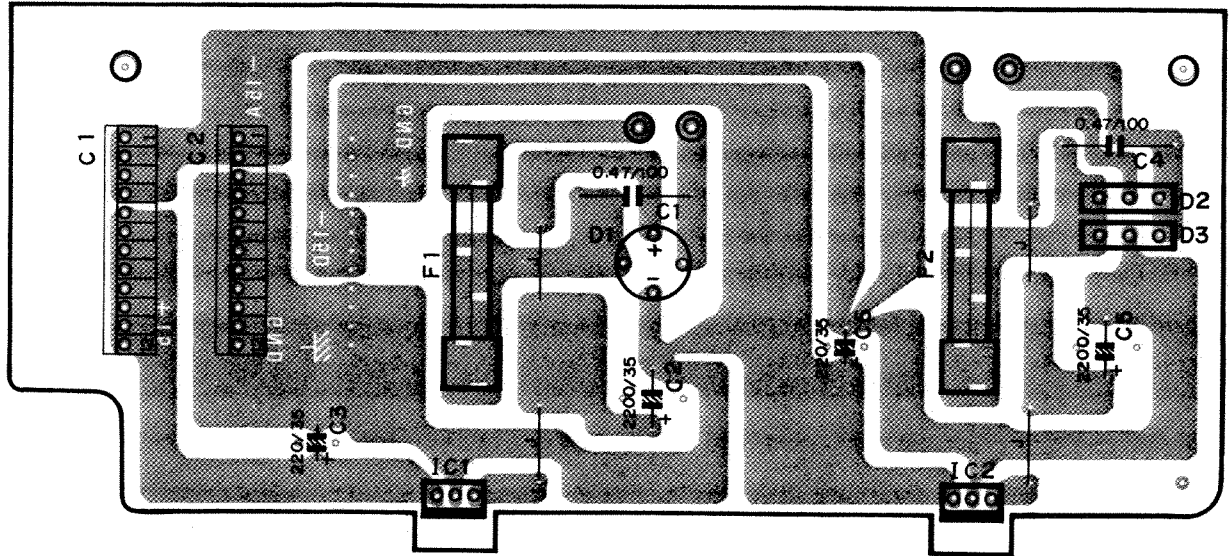

C1

Pin No.	Pin Name	Wire Color	Destination
1	-15	YE	DM--15D (C1-2)
2	-15	YE	CPA--15D (C5-1)
3	-15	YE	DM--15A (C7-10)
4	-15	YE	CPB--15A (C4-1)
5	+15	BR	DM+15D (C1-1)
6	+15	BR	CPB+15A (C4-6)
7	+15	BR	DM+15A (C7-4)
8	+15	BR	TE+15 (C1-1)
9	+15	-	-
10	+15	-	-
11	+15	-	-
12	+15	-	-

C2

Pin No.	Pin Name	Wire Color	Destination
1	-15	YE	TE--15 (C1-7)
2	-15	YE	CPB--15C (C1-2)
3	E	BL	DM-Vss (C1-4)
4	E	BL	DM-Vss (C1-5)
5	E	BL	DM-E (C7-6)
6	E	BL	CPB-E (C4-3)
7	E	BL	CPA-E (C4-4)
8	E	BL	CPA-Vss (C5-3)
9	E	BL	CPB-EC (C1-1)
10	E	BL	CPB-EC (C5-4)
11	E	BL	TE-E (C1-4)
12	E	BL	EP-1

Notes)

1. Circuit Board : LC 85553
2. IC  
IC 1,2 :  $\mu$ PC14315H
3. Diodes  
D1 : 1D4B1  
D2 : 1D2C1  
D3 : 1D2Z1



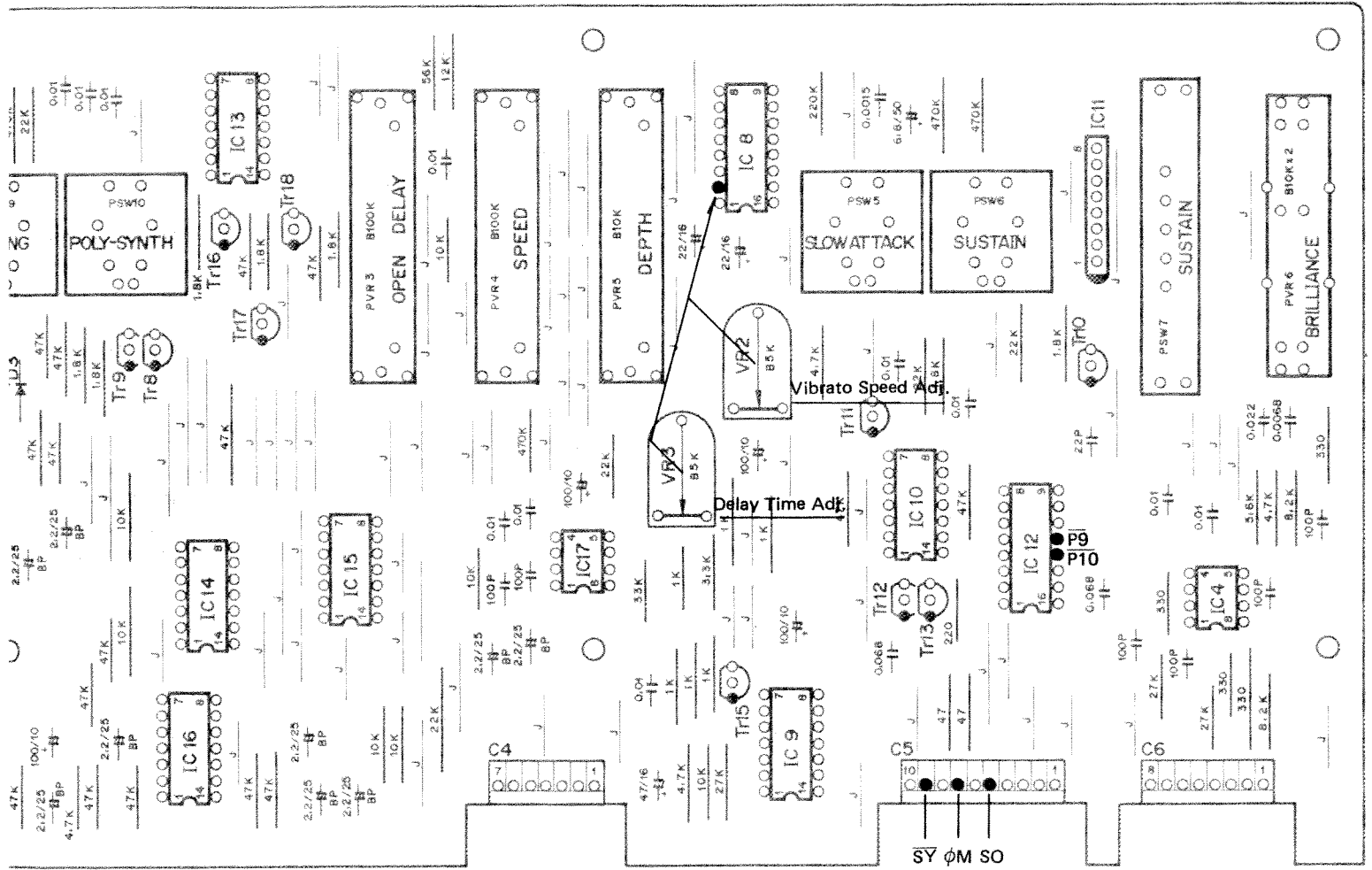

**CPB circuit board**

Item
<b>PERCUSSIVE</b> <b>2 2/3'</b>
<b>POLY-SYNTH</b> <b>Filter circuit</b>  <b>Peak Point</b>  <b>Peak level adjustment</b> <b>(Tone quality adjustment)</b>
<b>+10V adjustment</b>

PANEL LAYOUT

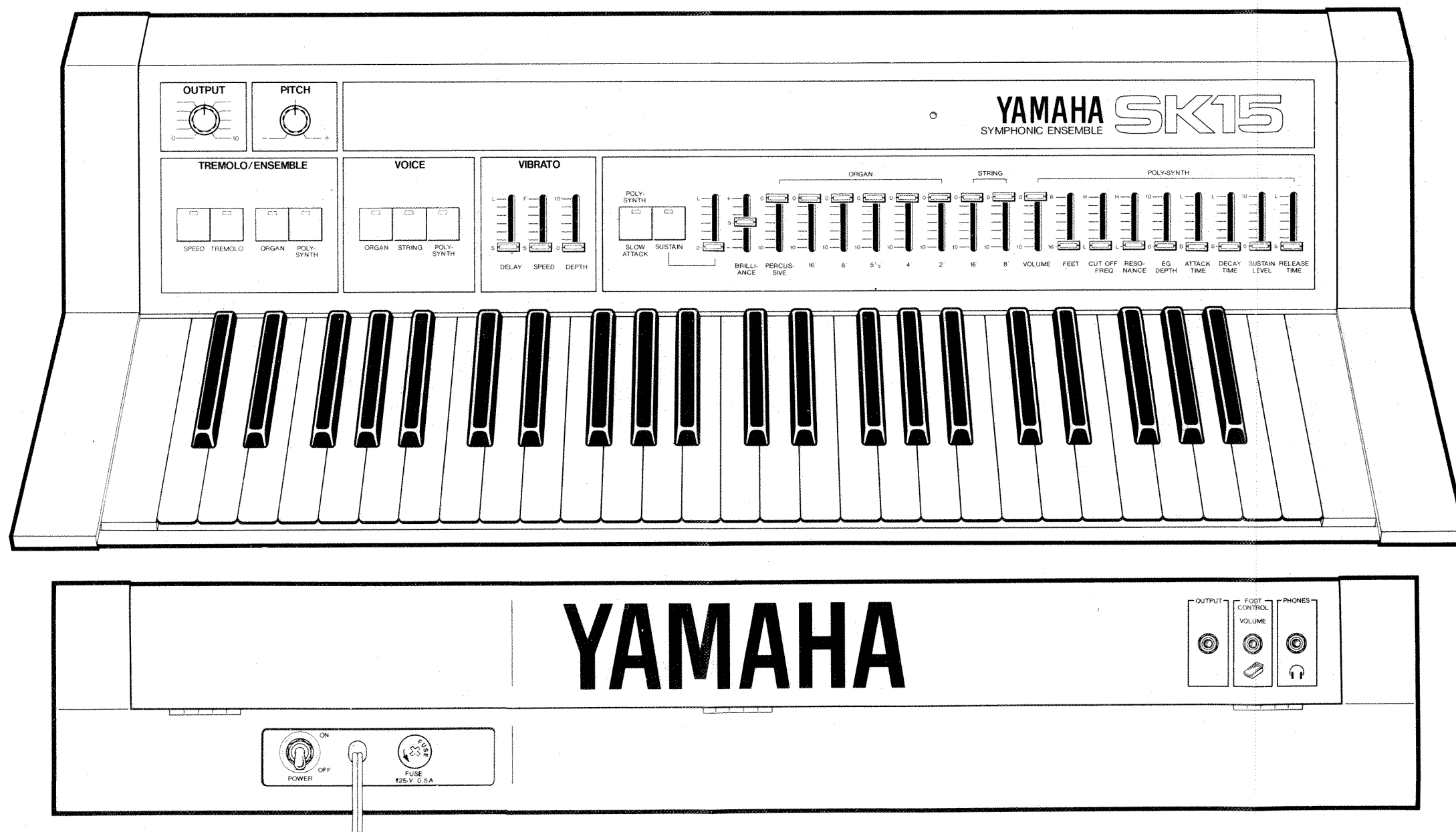

DM Circuit Board & Wiring

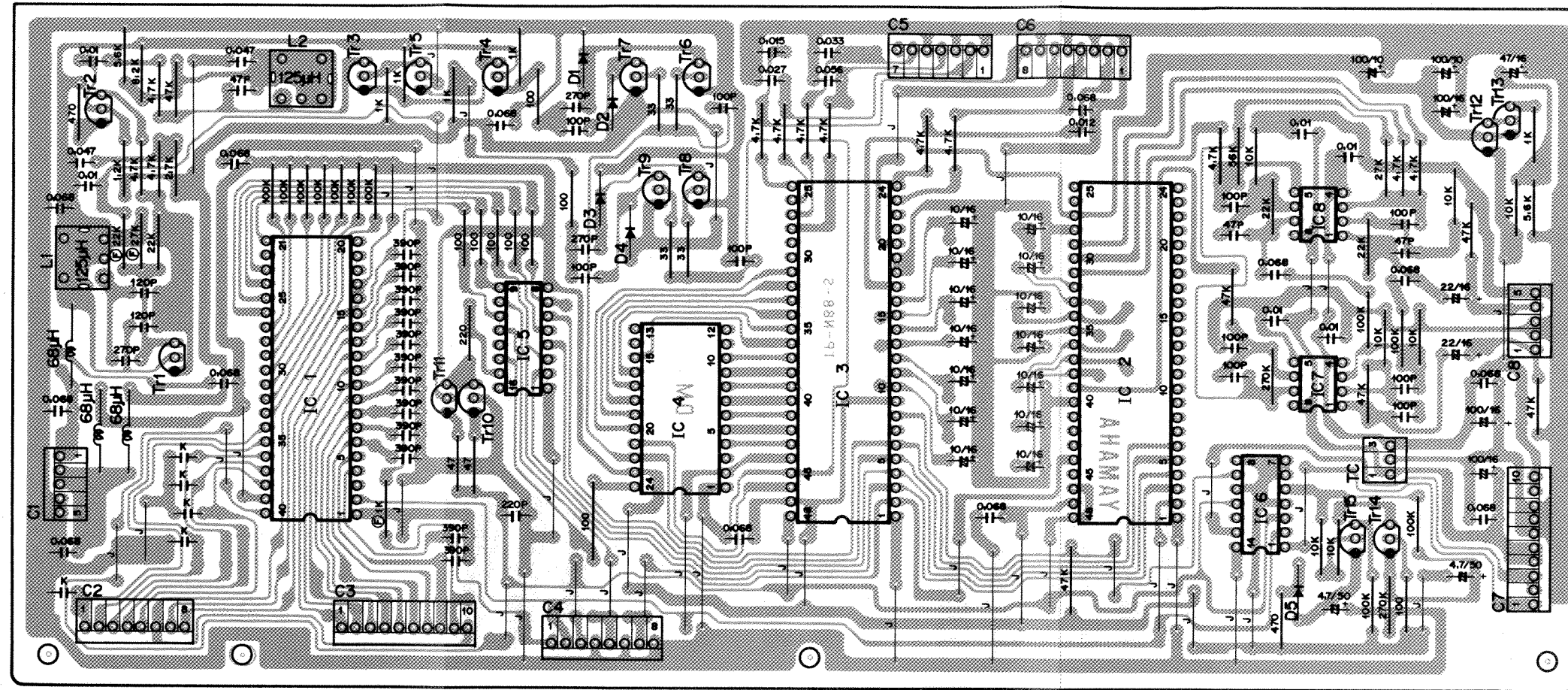

C1

+15D	1
-15D	2
-15D	3
VSS	4
VSS	5

C5

7	NC
6	B
5	E
4	16'
3	2
2	5 1/3'
1	E

C6

8	4'
7	ENC
6	E
5	2'
4	2'
3	2
2	2 2/3'
1	E

C8

8	E
4	P8'
3	E
2	P16'
1	P16'

C7

10	-15A
9	-15A
8	E
7	E
6	E
5	+15A
4	+15A
3	TR
2	TR
1	IC

- Notes)
- Circuit Board : LC 28951
  - IC
    - IC 1 : YM62100
    - IC 2 : YM70400
    - IC 3 : YM70200
    - IC 4 : YM62200
    - IC 5 : TC4050BP
    - IC 6 : TC4013BP
    - IC 7, 8 : NJM4558DV
  - Transistors
    - Tr1, 4, 5, 7, 9, 10: 2SC752(Y)
    - Tr2,3 : 2SA1164(Y)
    - Tr6, 8, 11 : 2SA1164(GR)
    - Tr12, 15 : 2SC1815(O,Y)
    - Tr13, 14 : 2SA1015(O,Y)
  - Diodes
    - D1 ~ 5 : 1S1555
  - Capacitor
    - (K) marked : Ceramic Capacitor 1000P
  - Resistor
    - ⊙ marked : Metal Oxide Film Resistor (± 1%)

C2

1	U1
2	U2
3	U3
4	U4
5	U5
6	C
7	B
8	A#

C3

1	A
2	G#
3	G
4	F#
5	F
6	E
7	D#
8	D
9	C#
10	C

C4

1	VM
2	IC
3	φM
4	VSS
5	SY
6	VSS
7	SI
8	VSS

C1

Pin No.	Pin Name	Wire Color	Destination
1	+15D	BR	DC-+15 (C1-5)
2	-15D	YE	DC-15 (C1-1)
3	-15D	-	-
4	Vss	BL	DC-E (C2-3)
5	Vss	BL	DC-E (C2-4)

C2

Pin No.	Pin Name	Wire Color	Destination
1	U1	RE	MK-B1 (C2-6)
2	U2	OR	MK-B2 (C2-7)
3	U3	YE	MK-B3 (C2-8)
4	U4	GR	MK-B4 (C2-9)
5	U5	BE	MK-B5 (C2-10)
6	C	BR	MK-C (C2-5)
7	B	PK	MK-B (C2-4)
8	A#	SB	MK-A# (C2-3)

C3

Pin No.	Pin Name	Wire Color	Destination
1	A	GG	MK-A (C2-2)
2	G#	WH	MK-G# (C2-1)
3	G	GY	MK-G (C1-8)
4	F#	VI	MK-F# (C1-7)
5	F	BE	MK-F (C1-6)
6	E	GR	MK-E (C1-5)
7	D#	YE	MK-D# (C1-4)
8	D	OR	MK-D (C1-3)
9	C#	RE	MK-C# (C1-2)
10	C	BR	MK-CL (C1-1)

C4

Pin No.	Pin Name	Wire Color	Destination
1	VM	GG	CPA-VM (C2-7)
2	IC	WH	CPA-IC (C2-4)
3	φM	S BE	CPA-φM (C5-7)
4	Vss	S BE S	-
5	SY	S VI	CPA-SY (C5-9)
6	Vss	S VI S	-
7	SI	S GR	CPA-SO (C5-5)
8	Vss	S GR S	-

C5

Pin No.	Pin Name	Wire Color	Destination
1	E	S OR S	-
2	5 1/3'	S OR	CPB-5 1/3' (C3-2)
3	E	S OR S	-
4	16'	S BR	CPB-16' (C2-6)
5	E	S RE S	-
6	8'	S RE	CPB-8' (C2-8)
7	NC	-	-

C6

Pin No.	Pin Name	Wire Color	Destination
1	E	S GR S	-
2	2 2/3'	S GR	CPB-2 2/3' (C1-6)
3	E	S BE	-
4	2'	S BE S	CPB-2' (C3-5)
5	E	S WH S	-
6	ENC	S WH	CPB-ENC (C2-4)
7	E	S YE S	-
8	4'	S YE	CPB-4' (C3-4)

C7

Pin No.	Pin Name	Wire Color	Destination
1	IC	-	-
2	TR	BE	CPA-VTR (C2-1)
3	TR	BE	CPB-TR (C1-3)
4	+15A	BR	DC-+15 (C1-7)
5	+15A	-	-
6	E	BL	DC-E (C2-5)
7	E	-	-
8	E	-	-
9	-15A	-	-
10	-15A	YE	DC-15 (C1-3)

C8

Pin No.	Pin Name	Wire Color	Destination
1	P16'	S VI	CPB-P16' (C3-8)
2	E	S VI S	-
3	E	-	-
4	P8'	S GY	CPB-P8' (C3-10)
5	E	S GY S	-



## BASIC SETTING

BLOCK	CONTROL	SETTING
OUTPUT	MASTER VOLUME	10
PITCH		CENTER
SWITCH BLOCK		
TREMOLO/ENSEMBLE	SPEED TREMOLO, ORGAN POLY-SYNTH	ALL OFF (LED OFF)
VOICE	ORGAN, STRING, POLY-SYNTH	ALL ON (LED ON)
VIBRATO	DELAY, SPEED	S
	DEPTH	O
	POLY-SYNTH, SUSTAIN SWITCH	
TONE CONTROL Section	POLY-SYNTH, SUSTAIN	ALL OFF (LED OFF)
	SUSTAIN LEVER	S
	BRILLIANCE LEVER	CENTER
	ORGAN, STRING LEVER 16', 8'	O
	PERCUSSIVE, 16' ~ 2	
POLY-SYNTH	VOLUME LEVER	O
	FEET LEVER	16'
	CUT OFF, RESONANCE LEVER	L
	EG-DEPTH LEVER	O
	AT, DT, RT LEVER	S
	SUSTAIN LEVER	O

## Adjustments and Inspection Standards

### CIRCUIT BOARDS FUNCTIONS

Circuit boards	Functions	Circuit boards	Functions
CPA	VIBRATO Circuit Pitch control circuit TREMLO, SPEED Switch Circuit ENSEMBLE (ORGAN, POLY-SYNTH) Switch Circuit VOICE Select Switch Circuit SLOW ATTACK-SUSTAIN Switch Circuit SUSTAIN TIME CONTROL Circuit BRILLIANCE Circuit EXP Circuit Foot control Circuit Output amplifier circuit Headphones circuit -5V Generator	DM	Master Clock Circuit Initial Clear Circuit (KAC) Wave Generator Circuit Click Cancel Circuit POLY-SYNTH Waveform MIX Circuit
		TE	Input LPF Circuit  BBD Clock Generator Circuit BBD Driver Circuit Output LPF Circuit Amplitude Modulation Circuit
		DC	+15V Regulator -15V Regulator
CPB	ORGAN Tone circuit (16', 8', 5 1/3', 4', 2') PERCUSSIVE Tone circuit STRING Tone circuit (16', 8') POLY-SYNTH Tone circuit (VCF) POLY-SYNTH EG Circuit		

### DM circuit board

Item	Setting	Test point	Adjustment & reading	Where to adjustment	Remark
Pitch	ORGAN 8' 10	OUTPUT	A3 Key ON	DM Circuit	
	PITCH VR Center		A3 = 443Hz	L1	Adjustment
		Tr3 Emitter	maximum amplitude	L2	Adjustment
-5V Regulator		Tr13 Emitter	-5V ± 0.5V		Check

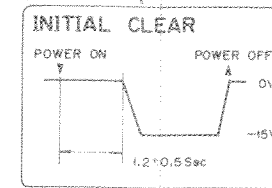
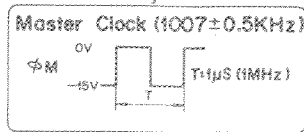
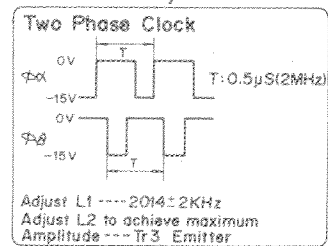
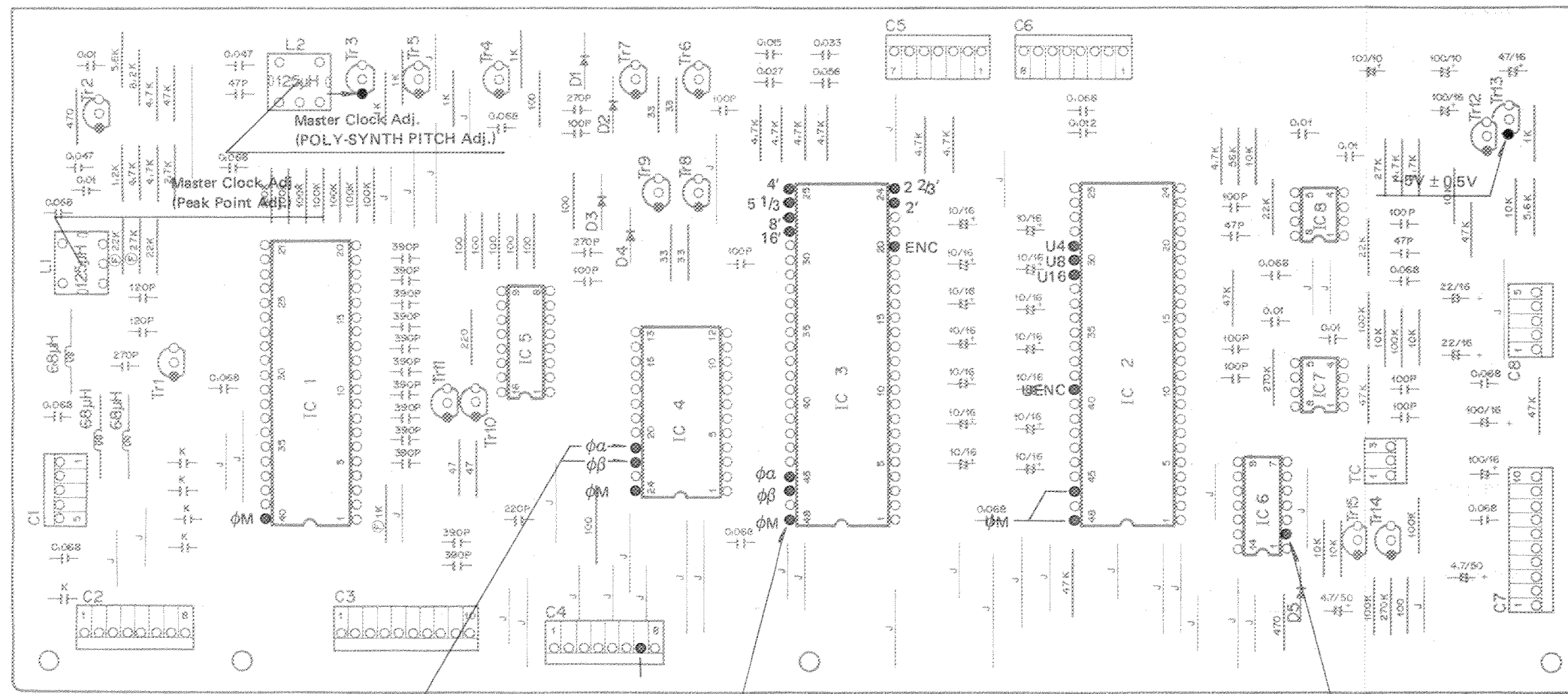



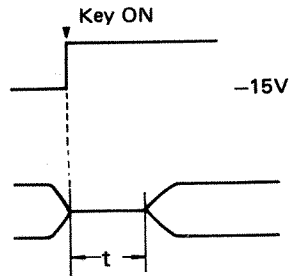

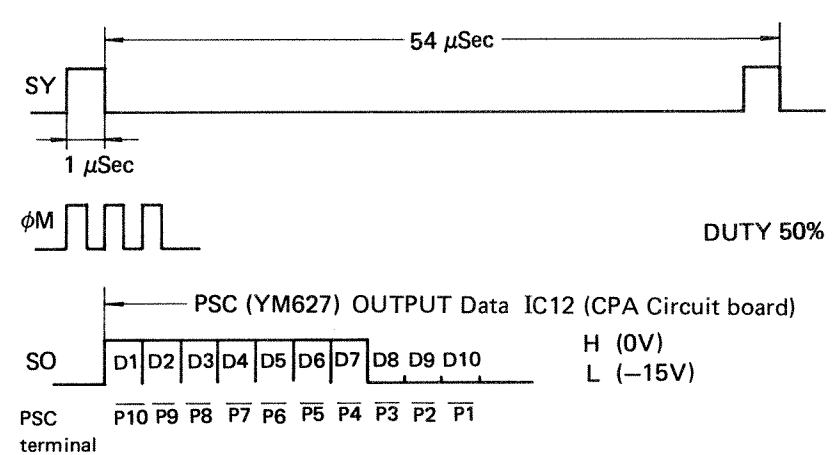
CPA circuit board

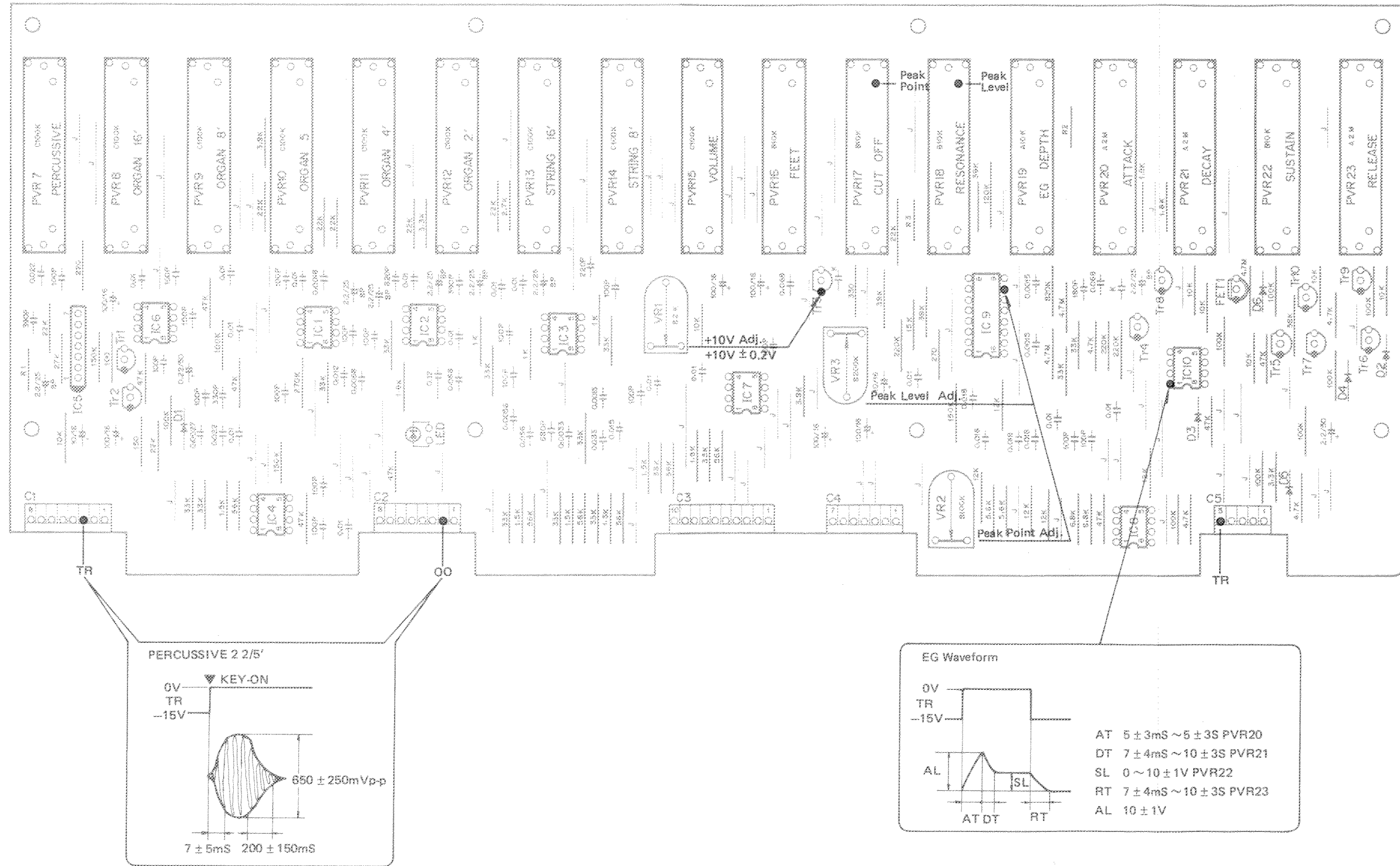
Item	Setting	Test point	Adjustment & reading	Where to adjustment	Remark
VIBRATO Block					
VIB-DEPTH	DEPTH VR 0 PITCH VR - (MIN) + (MAX)	VM (C2-7)	-2.5 ± 0.5V 438Hz +2.5V ±		Check Check
PITCH	PITCH VR Center	VM (C2-7)	0V ± 0.1V 443Hz		Check
SPEED adjustment	DEPTH VR 10 SPEED VR S	VM (C2-7)	3.3V ± 0.3Vp-p t = 0.2sec (f = 5 ± 1Hz)	VR2 B-5KΩ	
	SPEED VR F	VM (C2-7)	t = 0.143sec (f = 7 ± 0.3Hz)		Check
DELAY TIME adjustment			When depressing any key, the waveform should appear as shown below.		
	VTR (C2-1)  VM (C2-7)  DELAY VR S L		 t = 0 t = 2.7 ± 0.6sec	VR3 B-5KΩ	Adjustment
+15V Protector		(C1-1)	+15V		Check

Item	Setting	Test point	Adjustment & reading	Where to adjustment	Remark
Output level	ORGAN SW ON ORGAN 8' ..... 10 Depress the C5 key	OUT (C1-6)	Adjust to achieve three times as much as OR (C4-2)	VR1 B-10KΩ	Adjustment
	OUTPUT VR ..... 10 STRING SW ON STRING 8' ..... 10 Depress the C5 key	OUT (C1-6)	Adjust to achieve three times as much as ST (C4-4)	VR1 B-10KΩ	Check
SLOW ATTACK SUSTAIN	Serial Data Timing Chart for (GF-1, GOA)				
					
	Note)				
	D1 : H or L		SLOW ATTACK/FAST		
	D2 : H or L		DAMP/SUSTAIN		
	D3 : L (fixed)				
	D4 : H (fixed)				
	D5 : H or L	S1	SUSTAIN Data		
	D6 : H or L	S2			
	D7 : H or L	S3			
	D8 : L (fixed)				
	D9 : L (fixed)				
	D10: L (fixed)				

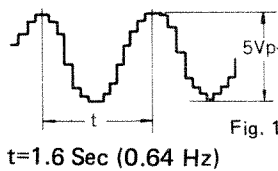

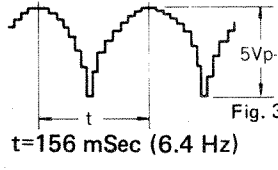
TE circuit board

Item	Setting	Test point	Adjustment & reading	Where to adjustment	Remark
T/E Clock Generator Circuit Ensemble Speed adjustment	TREMOLO/ENSEMBLE ENSEMBLE ... ON	O1 (IC1 - pin 16) O2 (IC1 - pin 15) O3 (IC1 - pin 14)  O4 (IC1 - pin 13) O5 (IC1 - pin 12) O6 (IC1 - pin 11)	The waveforms shown in Fig 1 and 2 should appear at O1, O2, O3, and O4, O5, O6 (IC1) terminal.  t=1.6 Sec (0.64 Hz) 	VR2	
Tremolo Speed adjustment	ENSEMBLE ... OFF TREMOLO ... ON	O1 (IC1 - pin 16)  O2 (IC1 - pin 15) O3 (IC1 - pin 14)  O4 (IC1 - pin 13) O5 (IC1 - pin 12) O6 (IC1 - pin 11)	The waveforms shown in Fig 3 should appear at O1. At this time adjust VR1 so that the frequency is 6.4Hz ± 0.1Hz.  t=156 mSec (6.4 Hz) The waveforms shown in Fig 4 should appear at O2, O3.  Check for a DC voltage of -2.5V.	VR1	
BBD Circuit	Connect pin 9 (TEST-Terminal) of IC1 to -15V.  Keyboard Endblock TREMOLO/ENSEMBLE TREMOLO ... ON  OUTPUT block ORGAN ..... 0  ORGAN block 8 ..... 10	Tr2-E Tr3-E Tr4-E	Adjust VR3, VR4, and VR5 for the best achievable sine wave.	VR3 VR4 VR5	

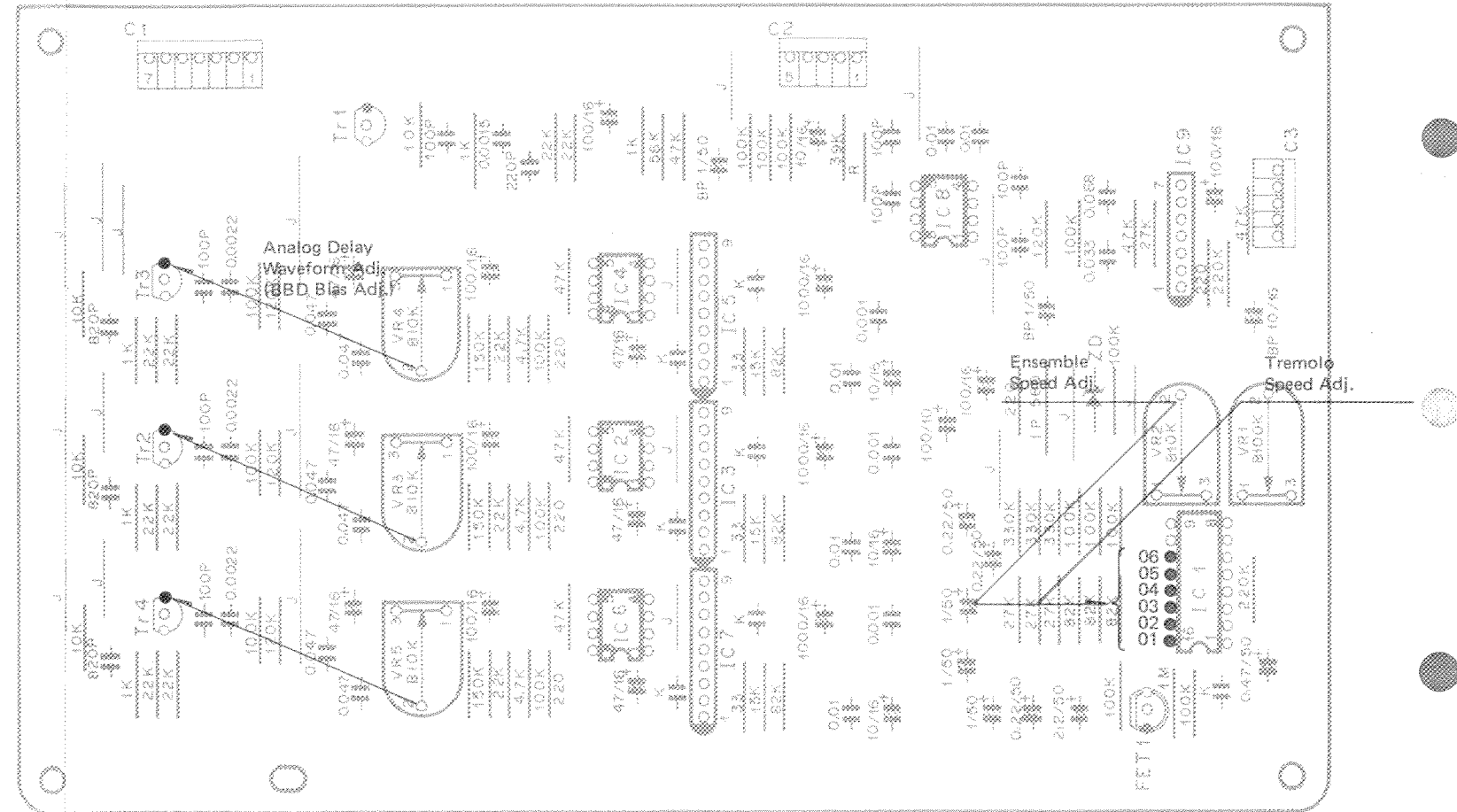

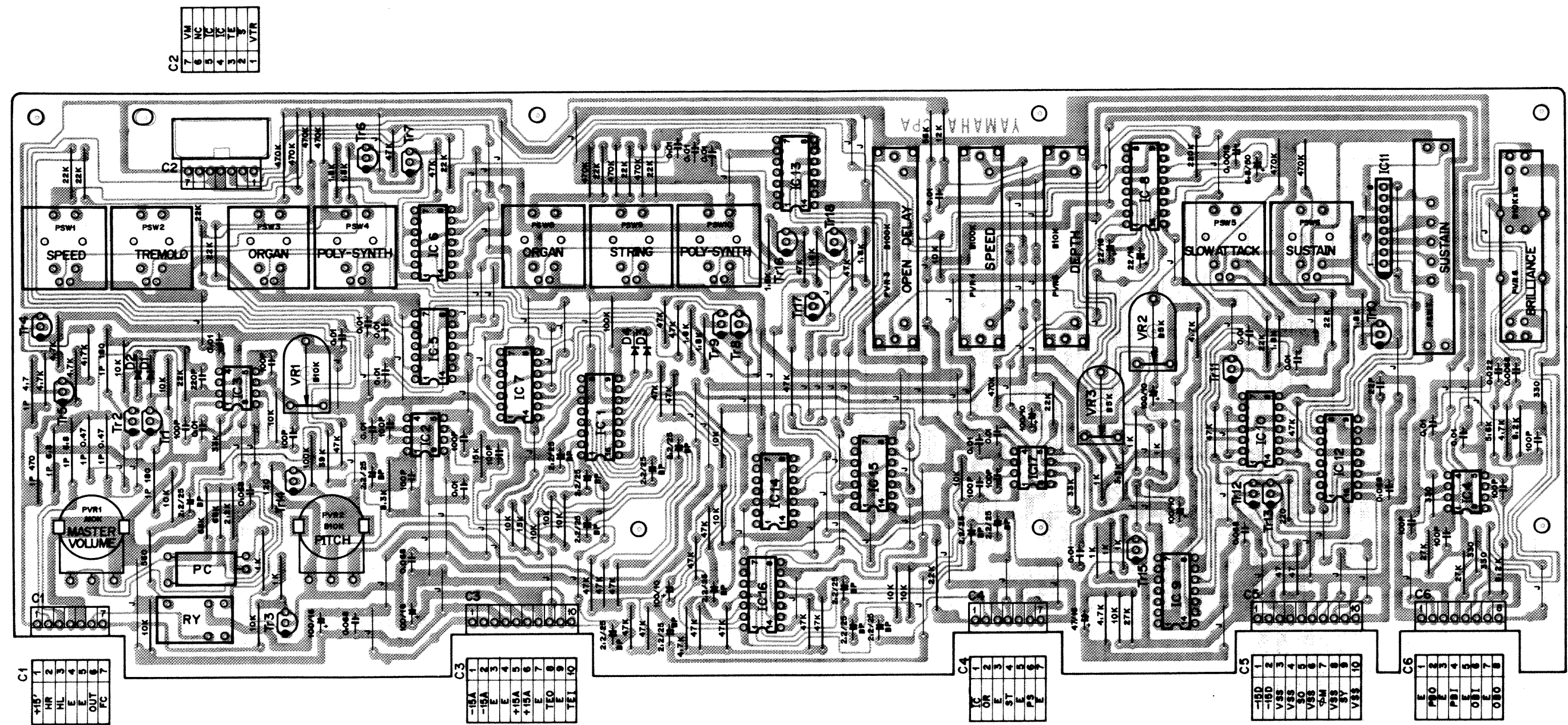

C2

7	VM
6	NC
5	IC
4	IC
3	TE
2	TE
1	VTR

C1

1	+15'
2	HR
3	HL
4	E
5	E
6	OUT
7	FC

C3

1	-15A
2	-15A
3	E
4	E
5	+15A
6	+15A
7	E
8	TEO
9	E
10	TEL

C4

1	IC
2	OR
3	E
4	ST
5	E
6	PS
7	E

C5

1	-15D
2	-15D
3	VSS
4	VSS
5	SO
6	VSS
7	-5M
8	VSS
9	SY
10	VSS

C6

1	PBO
2	E
3	PBI
4	E
5	OBI
6	E
7	E
8	OBU

C1

Pin No.	Pin Name	Wire Color	Destination
1	+15'	BR	JK+15' (C1-5)
2	HR	RE	JK-HR (C1-2)
3	HL	WH	JK-HL (C1-1)
4	E	BL	JK-E (C1-3)
5	E	S BR S	-
6	OUT	S BR	JK-OUT (C1-7)
7	FC	GR	JK-FC (C1-4)

C2

Pin No.	Pin Name	Wire Color	Destination
1	VTR	BE	DM-TR (C2-2)
2	S	VI	TE-S (C3-1)
3	TE	GY	TE-T/E (C3-2)
4	IC	WH	DM-IC (C4-1)
5	IC	WH	CPA-IC (C4-1)
6	NC	-	-
7	VM	GG	DM-VM (C4-1)

C3

Pin No.	Pin Name	Wire Color	Destination
1	-15A	YE	CPB--15A (C4-2)
2	-15A	-	-
3	E	BL	CPB-E (C4-5)
4	E	-	-
5	+15A	BR	CPB+15A (C4-7)
6	+15A	-	-
7	E	S GG S	-
8	TEO	S GG	TE-I (C2-4)
9	E	S SB S	-
10	TEI	S SB	TE-O (C3-3)

C4

Pin No.	Pin Name	Wire Color	Destination
1	IC	WH	CPA-IC (C2-5)
2	OR	S RE	CPA-OBO (C6-8)
3	E	S RE S	-
4	ST	S OR	CPA-PBO (C6-2)
5	E	S OR S	-
6	PS	S YE	CPA-PS (C1-8)
7	E	S YE S	CPB-PS (C1-8)

C5

Pin No.	Pin Name	Wire Color	Destination
1	-15D	YE	DC--15 (C1-2)
2	-15D	-	-
3	Vss	BL	DC-E (C2-6)
4	Vss	-	-
5	SO	S GR	DM-Si (C4-7)
6	Vss	S GR S	-
7	φM	S BE	DM-φM (C4-3)
8	Vss	S BE S	-
9	SY	S VI	DM-SY (C4-5)
10	Vss	S VI S	-



CPB Circuit Diagram

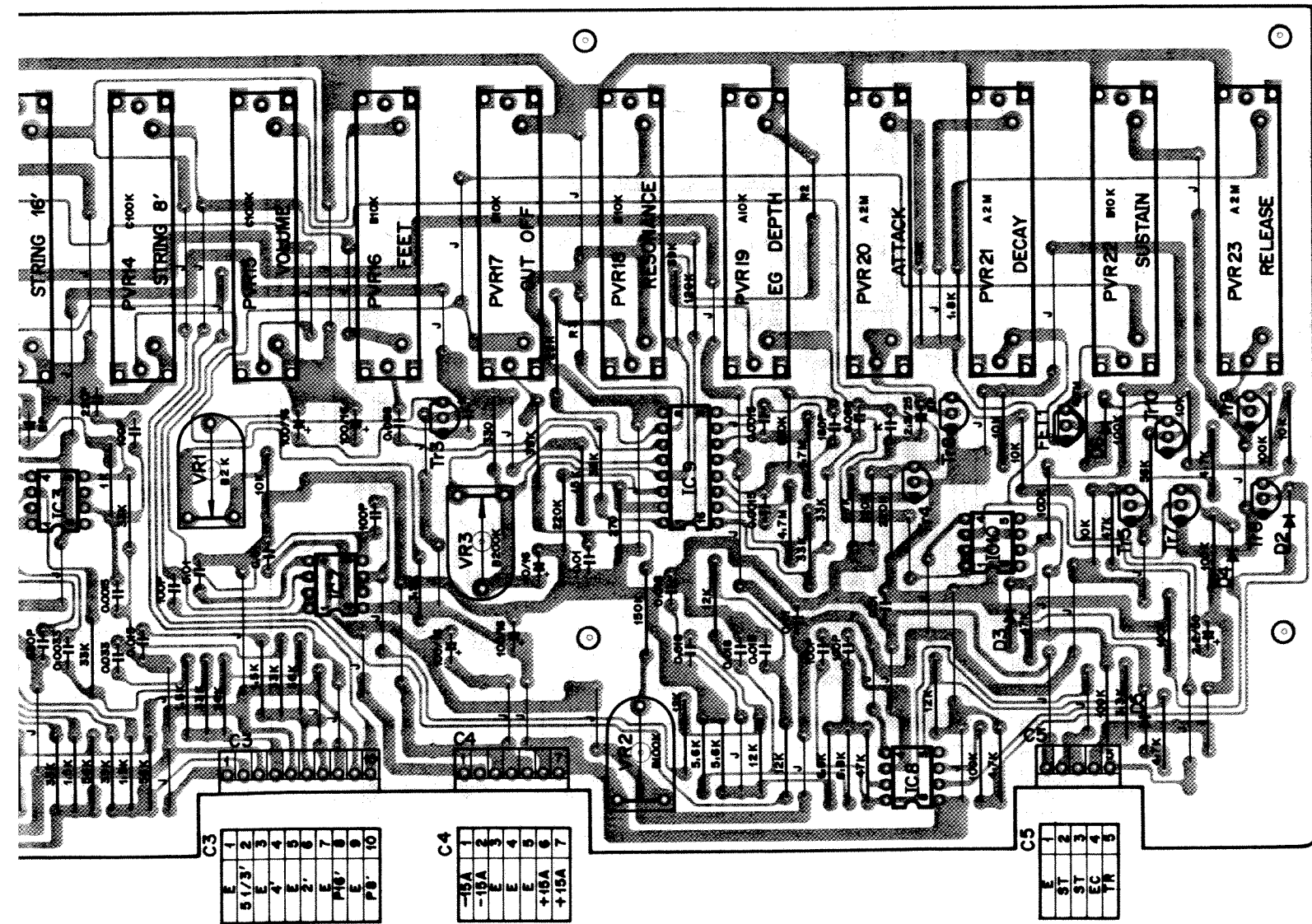

C1

Pin No.	Pin Name	Wire Color	Destination
1	EC	BL	DC-E (C2-9)
2	-15C	YE	DC -15 (C2-2)
3	TR	BE	DM-TR (C7-3)
4	TR	BE	CPB-TR (C5-5)
5	E	S GR S	
6	2 2/3'	S GR	DM-2 2/3' (C6-2)
7	E	S YE S	
8	PS	S YE	CPA-PS (C4-6)

C2

Pin No.	Pin Name	Wire Color	Destination
1	E	S YE S	
2	OO	S YE	CPA-OBI (C6-6)
3	E	S WH S	
4	ENC	S WH	DM-ENC (C6-6)
5	E	S BR S	
6	16'	S BR	DM-16' (C5-4)
7	E	S RES	
8	8'	S RE	DM-8' (C5-6)

C3

Pin No.	Pin Name	Wire Color	Destination
1	E	S OR S	
2	5 1/3'	S OR	DM-5 1/3' (C5-2)
3	E	S YE S	
4	4'	S YE	DM-4' (C6-8)
5	E	S BE S	
6	2'	S BE	DM-2' (C6-4)
7	E	S VIS	
8	P16'	S VI	DM-P16' (C8-1)
9	E	S GY S	
10	P8'	S GY	DM-P8' (C8-4)

C4

Pin No.	Pin Name	Wire Color	Destination
1	-15A	YE	DC -15 (C1-4)
2	-15A	YE	CPA -15A (C3-1)
3	E	BL	DC-E (C2-6)
4	E	BL	DC-E (C2-7)
5	E	BL	CPA-E (C3-3)
6	+15A	BR	DC+15 (C1-6)
7	+15A	BR	CPA+15A (C3-5)

C5

Pin No.	Pin Name	Wire Color	Destination
1	E	S GR S	
2	ST	S GR	CPA-PBI (C6-4)
3	ST	-	
4	EC	BL	DC-E (C2-10)
5	TR	BE	CPB-TR (C1-4)

Notes)

- Circuit Board : LC28942
- IC  
IC 1 ~ 4, 6 ~ 8, 10 : NJM4558DV  
IC 5 : iG02601  
IC 9 : iG00156
- Transistors  
Tr 1 ~ 7, 9 : 2SC1815(O) (Y)  
Tr 8, 10 : 2SA1015(O) (Y)
- FET  
FET 1 : 2SK30A(Y)
- Diodes  
D1 ~ 6 : 1S1555
- Capacitor  
(K) marked : Ceramic Capacitor 1000P



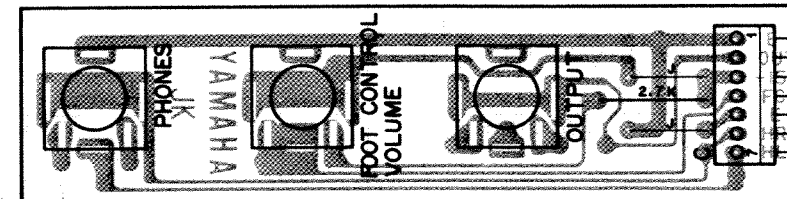
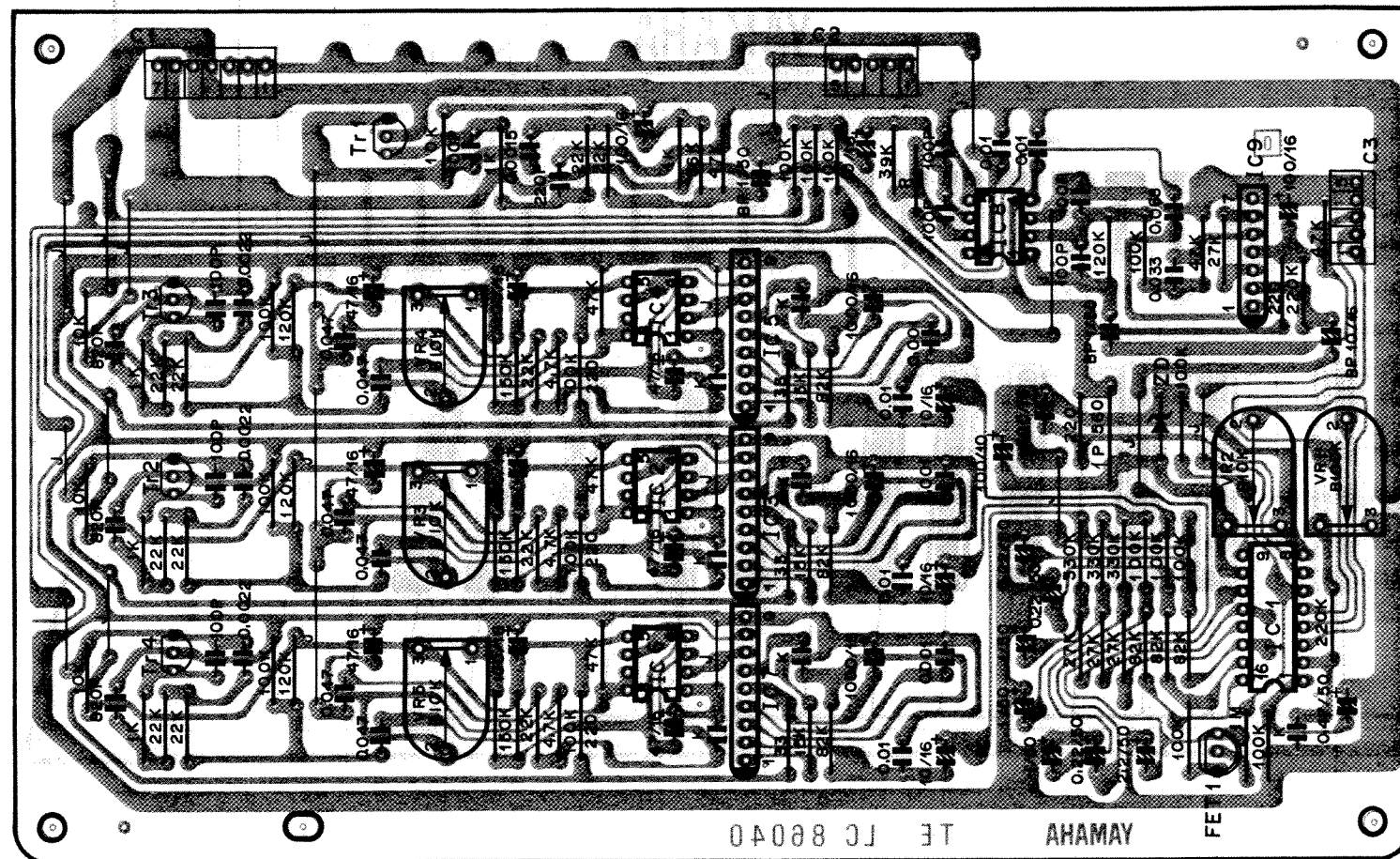

Pin No.	Pin Name	Wire Color	Destination
1	HL	WH	CPA-HL (C1-3)
2	HR	RE	CPA-HR (C1-2)
3	E	BL	CPA-E (C1-4)
4	FC	GR	CPA-FC (C1-7)
5	+15'	BR	CPA+15' (C1-1)
6	OUT	SBR	CPA-OUT (C1-6)
7	E	SBR S	-

C

Pin No.	Pin Name	Wire Color	Destination
1	HL	WH	CPA-HL (C1-3)
2	HR	RE	CPA-HR (C1-2)
3	E	BL	CPA-E (C1-4)
4	FC	GR	CPA-FC (C1-7)
5	+15'	BR	CPA+15' (C1-1)
6	OUT	SBR	CPA-OUT (C1-6)
7	E	SBR S	-

Notes)  
1. Circuit Board : LC 28942

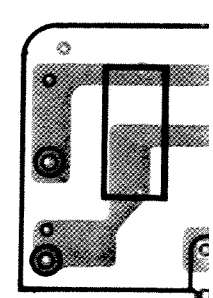
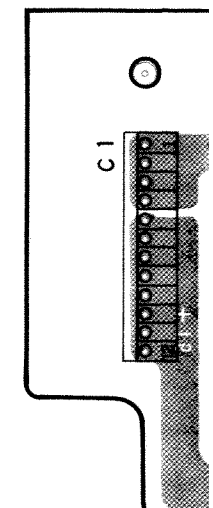

C1

Pin No.	Pin Name	Wire Color	Destination
1	+15	BR	DC+15 (C1-8)
2	+15	-	-
3	+15	-	-
4	E	BL	DC-E (C2-11)
5	E	-	-
6	-15	-	-
7	-15	YE	DC-15 (C2-1)

C3

Pin No.	Pin Name	Wire Color	Destination
1	S	VI	CPA-S (C2-2)
2	T/E	GY	CPA-TE (C2-3)
3	O	S SB	CPA-TEI (C3-10)
4	E	-	-
5	E	S SB S	-

C2

Pin No.	Pin Name	Wire Color	Destination
1	E	S GG S	-
2	E	-	-
3	E	-	-
4	I	S GG	CPA-TEO (C3-8)
5	I	-	-

Notes)

- Circuit Board : LC86041
- IC
  - IC 1 : YM63300
  - IC 2, 4, 6 : MN3009
  - IC 3, 5, 7 : iG03290
  - IC 8 : NJM4558DV
  - IC 9 : iG02590
- Transistors
  - Tr 1 ~ 4 : 2SC1815(O) (Y)
- FET
  - FET 1 : 2SK105F

- Diode
  - ZD : WZ050
- Capacitor
  - K marked : Ceramic Capacitor 1000P
- IC9 (iG02660, iG02590)

Rank	K	L	M
R	56K	47K	39K

C1

Pin No.	Pin Name	Wire Color	Destri
1	-15	YE	DM-15
2	-15	YE	CPA-15
3	-15	YE	DM-15
4	-15	YE	CPB-15
5	+15	BR	DM+15D
6	+15	BR	CPB+15A
7	+15	BR	DM+15A
8	+15	BR	TE+15 IC
9	+15	-	-
10	+15	-	-
11	+15	-	-
12	+15	-	-

PANEL SETTING

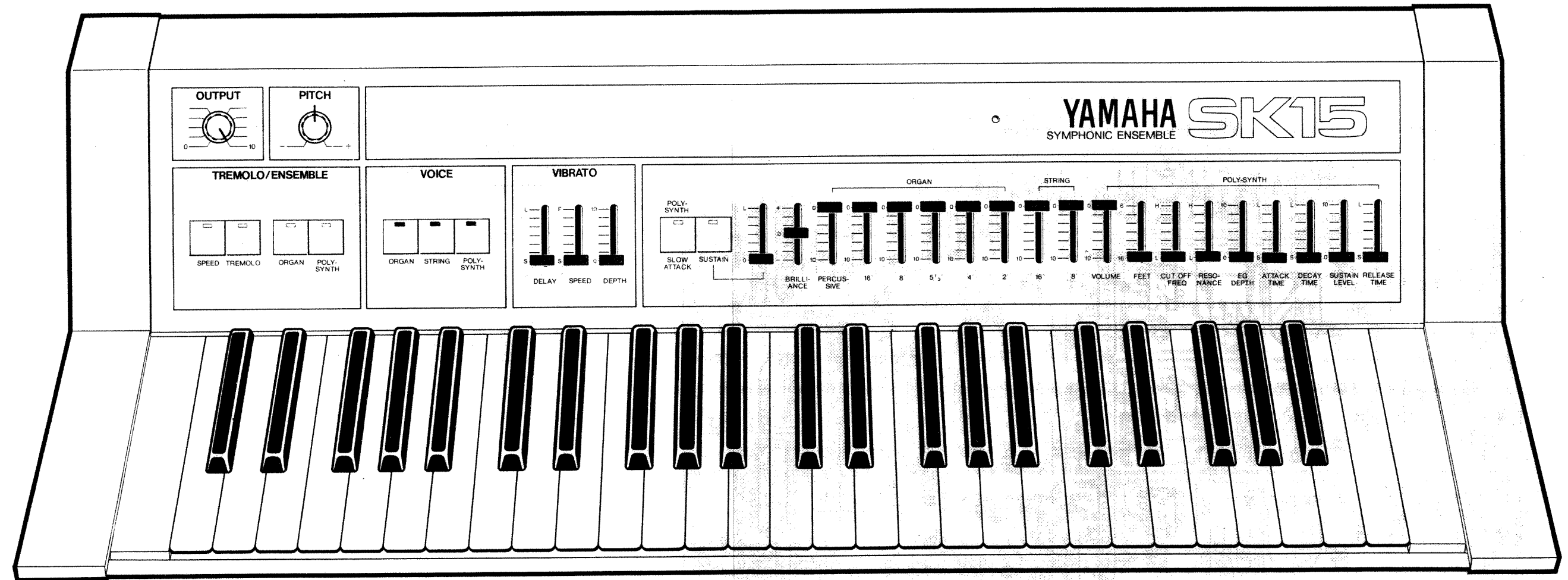

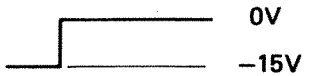
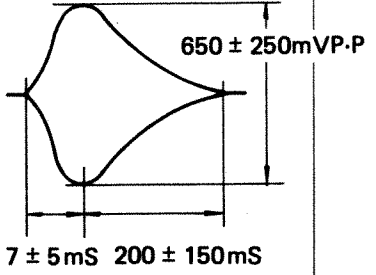
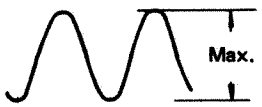
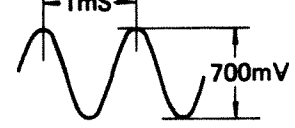

CPB circuit board

Item	Setting	Test point	Adjustment & reading	Where to adjustment	Remark
PERCUSSIVE 2 2/3'	Depress any key	TR (C1-3)			Check
	PERCUSSIVE (PVR7) ..... 10 Depress the C5 key	OO terminal (C2-2)			Check
POLY-SYNTH Filter circuit	FEET LEVER (PVR16) ..... 16				
	Peak Point CUT OFF FREQ (PVR17)	pin 2 TP34	+5V ± 0.2V	PVR17 set	Check
	Peak level adjustment (Tone quality adjustment)	pin 2 TP35	+5V ± 0.2V	PVR18 set	Check
	POLY-SYNTH VOLUME (PVR15) ..... 10 Depress the C5 key	PS (C1-8)	Peak Point 	VR2 (B100K)	Adjustment
			Peak level 	VR3 (B200K)	Adjustment
+10V adjustment		Tr3 Emitter	+10 ± 0.2V	VR1 (B2K)	Adjustment

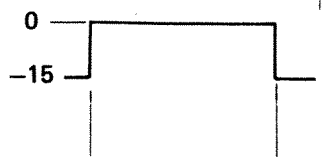
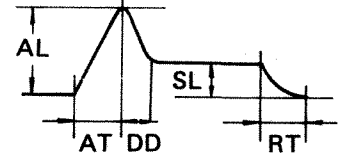
Item	Setting	Test point	Adjustment & reading	Where to adjustment	Remark
EG-waveform check	Depress any key	TR (C5-5)			Check
		IC 10½ pin 1			
		ATTACK TIME	5 ± 3mS ~ 3S	PVR20	Check
		DECAY TIME	7 ± 4mS ~ 10 ± 3S	PVR21	Check
		SUSTAIN LEVEL	0 ~ 1V	PVR22	Check
		RELEASE TIME	7 ± 4mS ~ 10 ± 3S	PVR23	Check
		ATTACK LEVEL	10 ± 1V (Usually)		Check

# YAMAHA

## SYMPHONIC ENSEMBLE

# SK15

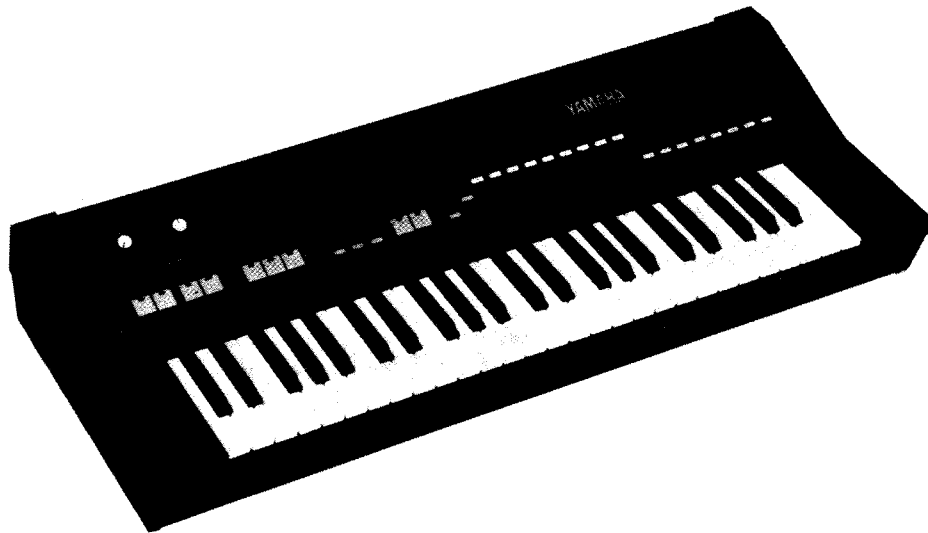

# SERVICE MANUAL



## CONTENTS(目次)

	CODING GUIDE (活用の手引).....	1
	Disassembly Procedure (分解手順).....	2
	SPECIFICATIONS (総合仕様).....	3
	PANEL LAYOUT.....	4
<b>DM</b>	Circuit Board & Wiring.....	6
<b>CPA</b>	Circuit Board & Wiring.....	8
<b>CPB</b>	Circuit Board & Wiring.....	11
<b>TE·JK·TC</b>	Circuit Board & Wiring.....	14
	PANEL SETTING.....	17
	Adjustment and Inspection Standards (検査調整基準).....	22
	<b>PARTS LIST</b>	

# CODING GUIDE (活用の手引)

## 1 Wiring Notation

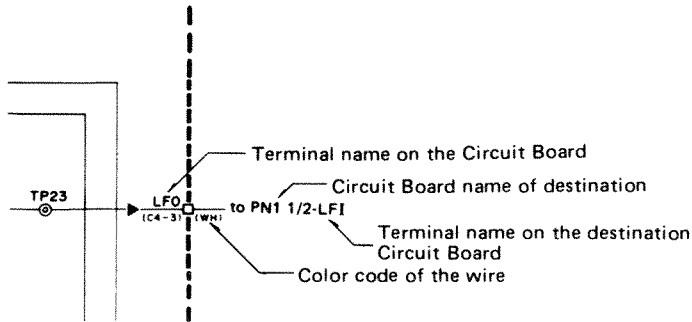

Note: Types of wire

— BL — Ordinary wire

— BL — Shielded wire

## 2 Symbol Description

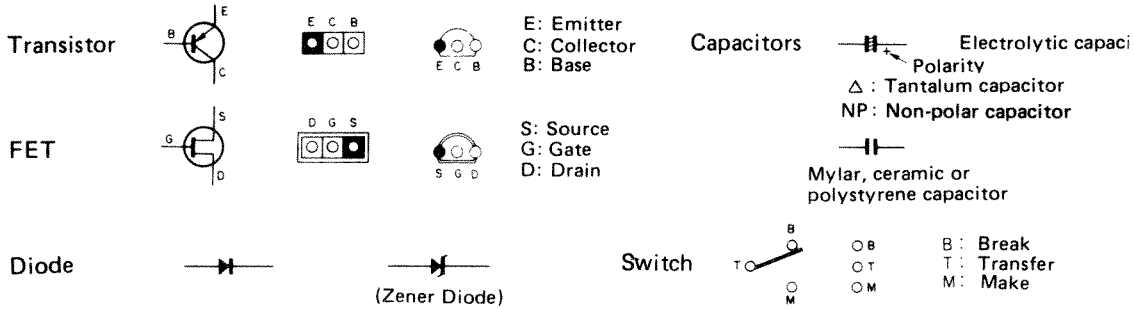

## 3 Abbreviations of Wire Color Codes

BLACK (クロ).....BL	BROWN (チャ).....BR	RED (アカ).....RE
ORANGE (タイ).....OR	YELLOW (キイ).....YE	GREEN (ミト).....GR
BLUE (アオ).....BE	VIOLET (ムラ).....VI	GRAY (ハイ).....GY
WHITE (シロ).....WH	GRASS GREEN (クサ).....GG	SKY BLUE (ソラ).....SB
PINK (モモ).....PK	TRANSPARENT (トウメイ).....TR	

## 4 Relation of Color Coding and Notes

C	C≠	D	D≠	E	F	F≠	G	G≠	A	A≠	B
BR	RE	OR	YE	GR	BE	VI	GY	WH	GG	SB	PK
(チャ)	(アカ)	(タイ)	(キイ)	(ミト)	(アオ)	(ムラ)	(ハイ)	(シロ)	(クサ)	(ソラ)	(モモ)

## 5 Logic Symbols

	MIL	YAMAHA
NOT (INVERTOR)		
NOR		
NAND		

Exclusive OR (排他的論理和)

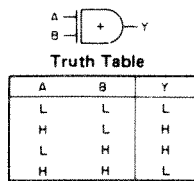

NOT (Inverter)

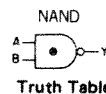
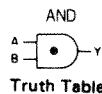
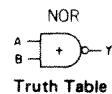
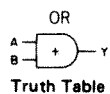
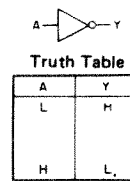



## DISASSEMBLY PROCEDURE(分解手順)

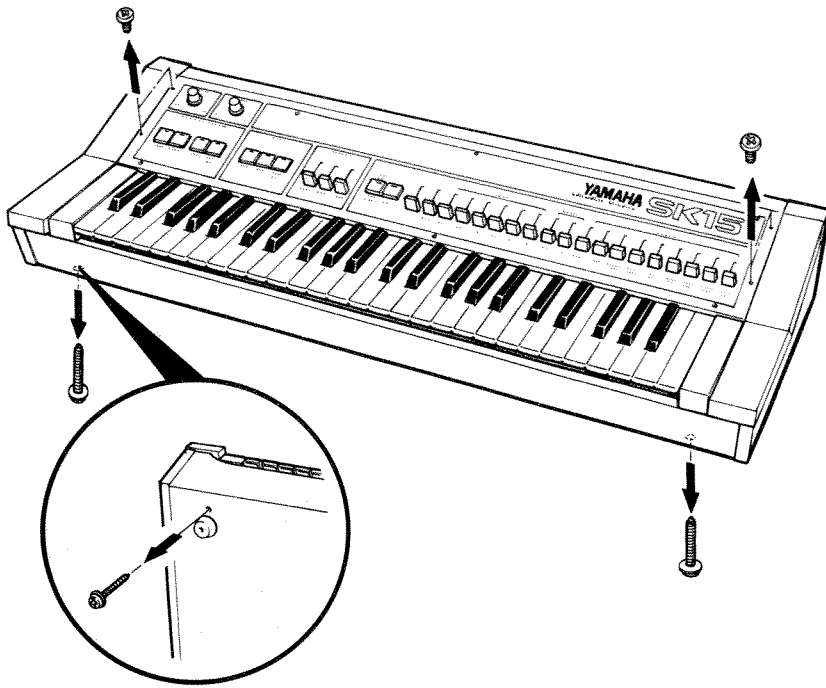

### Opening the Console Panel and Keyboard

パネル及び、鍵盤部の開閉

- Remove 6 screws from the console panel and bottom cover.
- 図のようにパネル面及び底板部のネジ合計6本を外します。

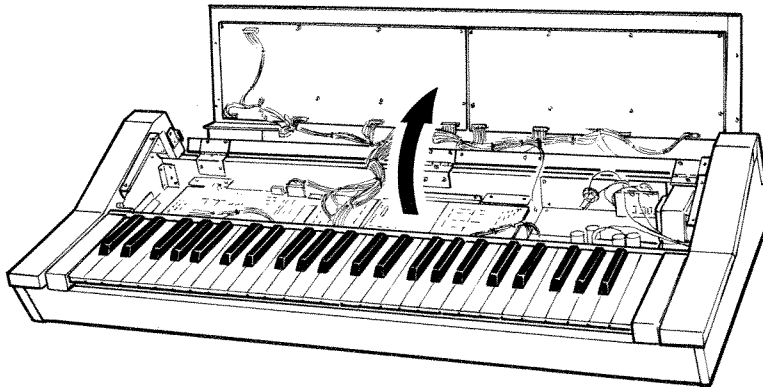

- Lift the panel as shown in the figure until it is fully opened.
- パネル部を図のように持ち上げ回転させて開けます。

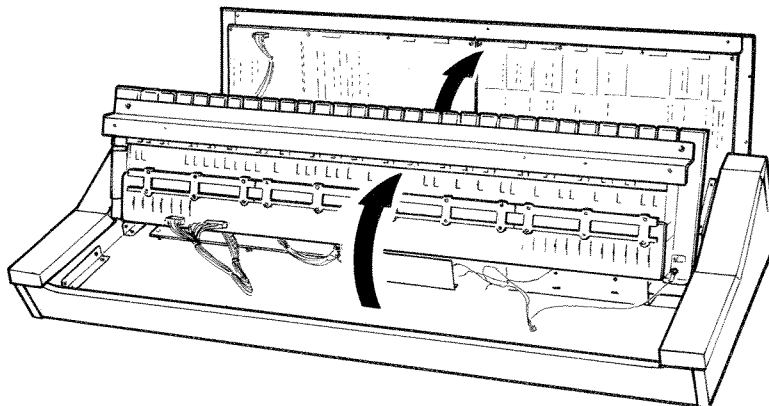

- The Keyboard can now be lifted as shown in the figure.
- パネルを上げた状態で鍵盤部を図のように回転させることができます。



**DC circuit board**

Item	Setting	Test point	Adjustment & reading	Where to adjustment	Remark
+15V		(C1-5 ~ 12)			Check
-15V		(C1-1 ~ 4) (C2-1 ~ 2)			Check

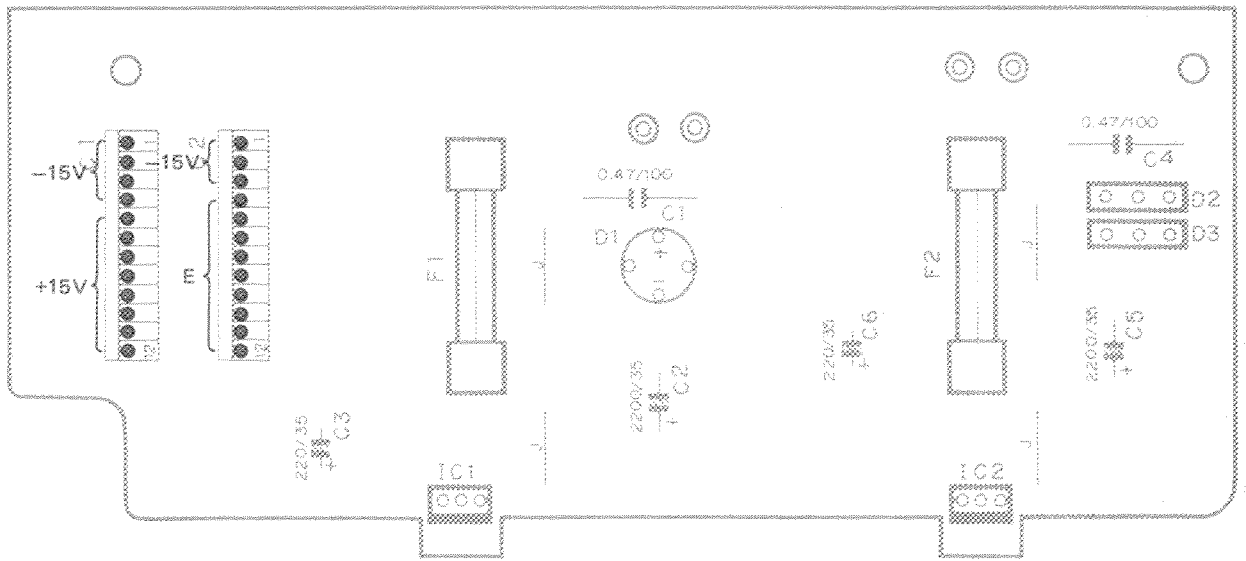

## LSI DATA TABLE

Part Name	YM62100	Function Name	KAC (Key Assigner)
-----------	---------	---------------	--------------------

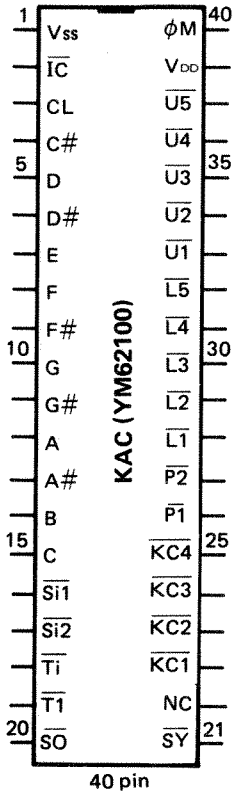

Pin No.	Name	Description	Pin No.	Name	Description
1	V <sub>ss</sub>	Ground (0V)	40	$\phi M$	Master clock in (1MHz)
2	$\overline{IC}$	Initial clear in	39	V <sub>DD</sub>	DC supply (-15V)
3	CL	Note block	38	$\overline{U5}$	UK octave block (C5# ~ C6)
4	C#	-do.-	37	$\overline{U4}$	-do.- (C4# ~ C5)
5	D	-do.-	36	$\overline{U3}$	-do.- (C3# ~ C4)
6	D#	-do.-	35	$\overline{U2}$	-do.- (C2# ~ C3)
7	E	-do.-	34	$\overline{U1}$	-do.- (C1 ~ C2)
8	F	-do.-	33	$\overline{L5}$	LK octave block (C5# ~ C6)
9	F#	-do.-	32	$\overline{L4}$	-do.- (C4# ~ C5)
10	G	-do.-	31	$\overline{L3}$	-do.- (C3# ~ C4)
11	G#	-do.-	30	$\overline{L2}$	-do.- (C2# ~ C3)
12	A	-do.-	29	$\overline{L1}$	-do.- (C1 ~ C2)
13	A#	-do.-	28	$\overline{P2}$	NC
14	B	-do.-	27	$\overline{P1}$	-do.-
15	C	-do.-	26	$\overline{KC4}$	Key code data out ( $\Rightarrow$ GF-1, GOA)
16	$\overline{Si1}$	VDD	25	$\overline{KC3}$	-do.- (-do.-)
17	$\overline{Si2}$	-do.-	24	$\overline{KC2}$	-do.- (-do.-)
18	$\overline{Ti}$	Test pin (-15V)	23	$\overline{KC1}$	-do.- (-do.-)
19	$\overline{T1}$	Test pin (-15V)	22	NC	-
20	$\overline{SO}$	VDD	21	$\overline{SY}$	Synchro data out 

Part Name	YM62200	Function Name	TGC (Tone Generator)
-----------	---------	---------------	----------------------

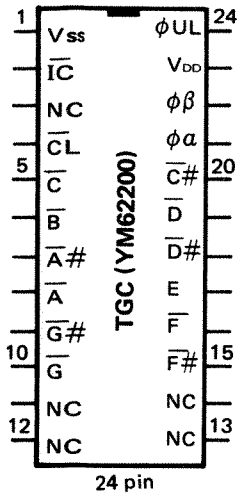

Pin No.	Name	Description	Pin No.	Name	Description
1	V <sub>SS</sub>	Ground (0V)	24	$\phi$ UL	Master Clock out (1MHz) NC
2	$\overline{\text{IC}}$	Initial clear in	23	V <sub>DD</sub>	DC supply (-15V)
3	NC	-	22	$\phi$ $\beta$	Master clock in (2MHz, anti phase to $\phi$ a)
4	$\overline{\text{CL}}$	Tone signal data out (serial data)	21	$\phi$ a	Master clock in (2MHz)
5	$\overline{\text{C}}$	-do.-	20	$\overline{\text{C\#}}$	Tone signal data out (serial data)
6	$\overline{\text{B}}$	-do.-	19	$\overline{\text{D}}$	-do.-
7	$\overline{\text{A\#}}$	-do.-	18	$\overline{\text{D\#}}$	-do.-
8	$\overline{\text{A}}$	-do.-	17	$\overline{\text{E}}$	-do.-
9	$\overline{\text{G\#}}$	-do.-	16	$\overline{\text{F}}$	-do.-
10	$\overline{\text{G}}$	-do.-	15	$\overline{\text{F\#}}$	-do.-
11	NC	-	14	NC	-
12	NC	-	13	NC	-

Part Name	YM62600	Function Name	DVG (Delay Vibrato Generator)
-----------	---------	---------------	-------------------------------

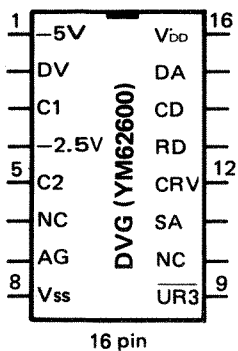

Pin No.	Name	Description	Pin No.	Name	Description
1	-5V	DC supply for vibrato signal	16	V <sub>DD</sub>	DC power supply (-15V)
2	DV	Delay vibrato signal out	15	DA	Delay time adjusting
3	C1	Capacitor for delay rise (positive side)	14	CD	Capacitor for delay time setting
4	-2.5	Vibrato signal mid-point potential	13	RD	Resistor for delay time setting
5	C2	Capacitor for delay rise (negative side)	12	CRV	C-R for vibrato oscillation
6	NC	-	11	SA	Vibrato speed adjusting
7	AG	Vibrato signal GND	10	NC	-
8	V <sub>SS</sub>	Ground (0V)	9	$\overline{\text{UR3}}$	Key ON signal in $\square$ 30mSec

Part Name	YM62700	Function Name	PSC (Parallel-Serial Convertor)
-----------	---------	---------------	---------------------------------

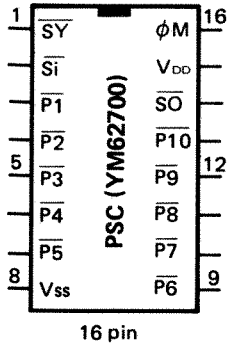

Pin No.	Name	Description	Pin No.	Name	Description
1	SY	Synchro-pulse input (≡ KAC)	16	φM	Master clock input
2	Si	Serial data input NC	15	V <sub>DD</sub>	DC power supply (-15V)
3	P1	Parallel data input 1	14	SO	Serial data output (≡ GF-1, GOA)
4	P2	-do.- 2	13	P10	Parallel data input 10
5	P3	-do.- 3	12	P9	-do.- 9
6	P4	-do.- 4	11	P8	-do.- 8
7	P5	-do.- 5	10	P7	-do.- 7
8	V <sub>SS</sub>	DC power supply (0V)	9	P6	-do.- 6

Part Name	YM63300	Function Name	SECII (Symphonic Ensemble Clockgenerator II)
-----------	---------	---------------	--

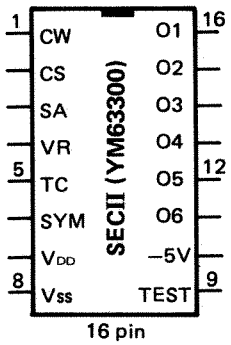

Pin No.	Name	Description	Pin No.	Name	Description
1	CW	CR for Wind up time	16	O1	Tremolo Ensemble clock OUT
2	CS	Speed set at fast	15	O2	-do.-
3	SA	Speed set at slow	14	O3	-do.-
4	VR	Tremolo speed set	13	O4	Ensemble clock OUT
5	TC	Slow/Fast change data IN	12	O5	-do.-
6	SYM	Tremolo/Ensemble change data IN	11	O6	-do.-
7	V <sub>DD</sub>	Power supply (-15V)	10	-5V	Power supply for clock (-5V)
8	V <sub>SS</sub>	Ground (0V)	9	TEST	Test pin

Part Name	YM70200	Function Name	GF-1 (Generator of Flute – 1)
-----------	---------	---------------	-------------------------------

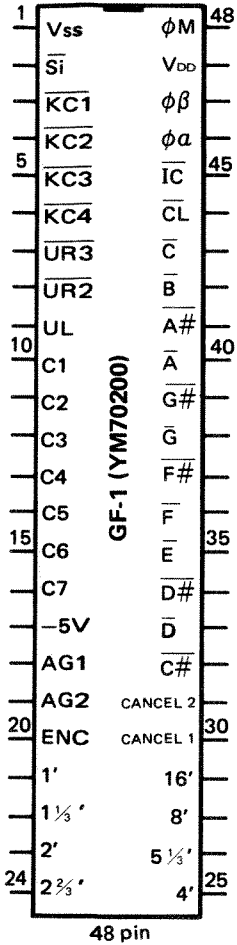

Pin No.	Name	Description	Pin No.	Name	Description
1	Vss	Ground (0V)	48	$\phi M$	Master clock in (1MHz)
2	$\overline{Si}$	Serial data in (sustain) ( $\leftrightarrow$ PSC)	47	V <sub>DD</sub>	DC supply (-15V)
3	$\overline{KC1}$	Key code data in ( $\leftrightarrow$ KAC)	46	$\phi\beta$	Master clock in(2MHz, anti phase to $\phi\alpha$ )
4	$\overline{KC2}$	-do.-	45	$\phi\alpha$	Master clock in (2MHz)
5	$\overline{KC3}$	-do.-	44	$\overline{IC}$	Initial clear in
6	$\overline{KC4}$	-do.-	43	$\overline{CL}$	Tone signal data in (serial data $\leftarrow$ TGC)
7	$\overline{UR3}$	Key ON data out NC	42	$\overline{C}$	-do.-
8	$\overline{UR2}$	-do.-	41	$\overline{B}$	-do.-
9	UL	UK/LK control data in (V <sub>ss</sub> : LK V <sub>DD</sub> : UK)	40	$\overline{A\#}$	-do.-
10	C1	Capacitor for ORGAN signal envelope setting	39	$\overline{A}$	-do.-
11	C2	-do.-	38	$\overline{G\#}$	-do.-
12	C3	-do.-	37	$\overline{G}$	-do.-
13	C4	-do.-	36	$\overline{F\#}$	-do.-
14	C5	-do.-	35	$\overline{F}$	-do.-
15	C6	-do.-	34	$\overline{E}$	-do.-
16	C7	-do.-	33	$\overline{D\#}$	-do.-
17	-5V		32	$\overline{D}$	-do.-
18	AG1	Envelope GND	31	$\overline{C\#}$	-do.-
19	AG2	Signal GND	30	CANCEL 2	
20	ENC	Click cancel signal out	29	CANCEL 1	NC
21	1'	Signal out (sine wave)	28	16'	Signal out (sine wave)
22	1 1/2'	-do.-	27	8'	-do.-
23	2'	-do.-	26	5 1/2'	-do.-
24	2 1/2'	-do.-	25	4'	-do.-

Part Name	YM70400	Function Name	GOA (Generator of Orchestra & ABC)
-----------	---------	---------------	------------------------------------

Pin No.	Name	Description	Pin No.	Name	Description
1	V <sub>ss</sub>	Ground (0V)	48	φM	Master clock in
2	IC	Initial clear in	47	V <sub>DD</sub>	DC power supply (-15V)
3	KC1	Key code data in	46	φUL	Master clock in (tone generator)
4	KC2	-do.-	45	LSi	NC
5	KC3	-do.-	44	USi	Serial data in (sustain, slow AT) (↔PSC)
6	KC4	-do.-	43	NC	NC
7	CWG	NC	42	NC	-do.-
8	CA2	-do.-	41	RWG	-do.-
9	CA1	-do.-	40	AG1	Ground (envelope)
10	-8V	-do.-	39	UENC	Click cancel signal OUT
11	LAG1	-do.-	38	CU1	Capacitor of POLY-SYNTH signal envelope setting
12	CL7	-do.-	37	CU2	-do.-
13	CL6	-do.-	36	CU3	-do.-
14	CL5	-do.-	35	CU4	-do.-
15	CL4	-do.-	34	CU5	-do.-
16	CL3	-do.-	33	CU6	-do.-
17	CL2	-do.-	32	CU7	-do.-
18	CL1	-do.-	31	U16	Signal OUT 16' □ 1 : 1
19	WG	-do.-	30	U8	-do.- 8' □ 1 : 1
20	ABC2	-do.-	29	U4	-do.- 4' □ 1 : 1
21	ABC1	-do.-	28	UAG2	Ground (tone generator)
22	LAG2	-do.-	27	-5V	DC supply (-5V, tone generator)
23	L4	-do.-	26	NC	NC
24	L8	-do.-	25	LENC	-do.-

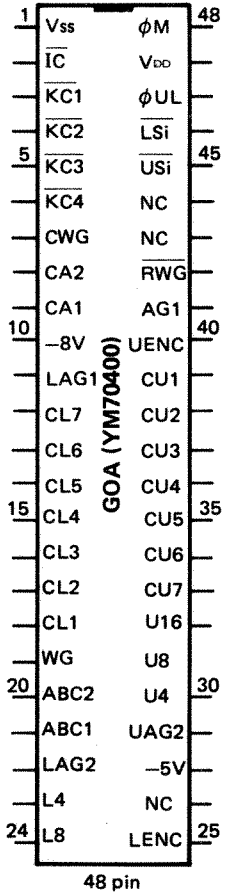



# YAMAHA

SYMPHONIC ENSEMBLE

SK15

## PARTS LIST

### CONTENTS

A. Electronic Components.....	1
B. Keyboard Assembly .....	4
C. Control Panel .....	5
D. Cabinet Assembly .....	7

## A. Electronic Components

Ref. No.	Part No.	Description	部 品 名	Remarks	Common Model	Markets
*	NA 10 69 10	Circuit Board , MK	#2921	M K シ ー ト		
*	NA 10 71 40	- do. - , CPA.CPB.JK	#2894	CPA・CPB・JK シ ー ト		
*	NA 10 71 50	- do. - , DM	#2895	D M シ ー ト		
*	NA 10 71 60	- do. - , DC	#8555	D C シ ー ト		J
*	NA 10 71 70	- do. - , - do. -	- do. -	"		U
*	NA 10 71 80	- do. - , - do. -	- do. -	"		C
*	NA 10 71 90	- do. - , - do. -	- do. -	"		G
	NA 80 68 60	- do. - , TE	#8604	T E シ ー ト		
*	NB 10 33 30	Switch Unit		ス イ ッ チ ユ ニ ッ ト		
*	NB 10 33 40	Power Supply Unit		電 源 ユ ニ ッ ト		J
*	NB 10 33 50	- do. -		"		U
*	NB 10 33 60	- do. -		"		C
*	NB 10 33 70	- do. -		"		G
	i G 00 11 80	IC	TC4013BP	I C	D Flip-Flop	
	i G 00 13 90	- do. -	NJM4558DV	"	OP.Amp	
	i G 00 15 60	- do. -	#00156	"	VCF	
	i G 00 16 90	- do. -	TC4016BP	"	Bilateral SW	
	i G 00 17 40	- do. -	TC4050BP	"	Converter	
	i G 02 60 00	- do. -	#02600	"	VCA	
	i G 02 87 00	- do. -	μPC14315H	"	+15V Regulator	
	i G 03 28 00	- do. -	#03280	"	Diode Matrix	
	i G 03 29 00	- do. -	#03290	"	BBD Driver	
	i G 04 33 00	- do. -	TC4093BP	"	NAND	
	i G 04 61 00	- do. -	MN3009	"	256 Stage BBD	
*	i G 05 51 00	- do. -	TC4053BP	"	Multiplexer	
	i T 62 10 00	- do. -	YM62100	"	KAC	
	i T 62 20 00	- do. -	YM62200	"	TGC	
	i T 62 60 00	- do. -	YM62600	"	DVG	
	i T 62 70 00	- do. -	YM62700	"	PSC	
	i T 63 30 00	- do. -	YM63300	"	SEC II	
	i T 70 20 00	- do. -	YM70200	"	GF1	
	i T 70 40 00	- do. -	YM70400	"	GOA	
	i A 09 50 00	Transistor	2SA950(Y)	ト ラ ン ジ ス タ		
	i A 10 15 70	- do. -	2SA1015(O,Y)	"		
	i A 11 64 00	- do. -	2SA1164(Y)	"		
	i A 11 64 10	- do. -	2SA1164(GR)	"		
	i C 07 52 20	- do. -	2SC752(Y)	"		
	i C 18 15 70	- do. -	2SC1815(O,Y)	"		
	i C 21 20 00	- do. -	2SC2120(Y)	"		
	i E 00 00 10	FET	2SK30A(Y)	F E T		
	i E 10 12 30	- do. -	2SK105F	"		
	i F 00 00 40	Diode	1S1555	ダ イ オ ー ド		
	i F 00 08 80	- do. -	WZ050	"		
	i F 00 11 90	LED	TLR-124	L E D		
	i H 00 02 80	Diode	1D2C1	ダ イ オ ー ド		
	i H 00 02 90	- do. -	1D2Z1	"		
	i H 00 04 70	- do. -	1D4B1	"		

\* New Parts (新規部品)

Ref. No.	Part No.	Description	部 品 名	Remarks	Common Model	Markets
	i K 00 02 60	Photo Coupler	P873-G35-201B	フ ォ ト カ プ ラ ー		
	i L 00 02 70	Mica Base		マ イ カ ベ ー ス		
	CB 07 28 80	Insulation Bushing		絶 縁 ブ ッ シ ュ		
	FC 18 54 70	Metalized Mylar Cap.	0.47 $\mu$ F/100V	M M コ ン		
	FD 65 21 20	Polystyrene Capacitor	120PF	ス チ ロ ー ル コ ン デ ン サ		
	FD 65 22 70	- do. -	270PF	"		
	FL 63 71 00	B.P. Electrolytic Cap.	10 $\mu$ F/16V	B P ケ ミ コ ン		
	FL 64 62 20	- do. -	2.2 $\mu$ F/25V	"		
	FM 11 61 00	- do. -	1 $\mu$ F/50V	"		
	FR 16 42 20	Spark Suppressor Cap.	0.022 $\mu$ F	ス パ ー ク キ ラ ー コ ン デ ン サ		G
	FZ 00 01 10	- do. -	0.033 $\mu$ F	"		J,U
	FZ 00 09 50	- do. -	0.033 $\mu$ F	"		C
	FZ 00 28 50	Capacitor	0.0022 $\mu$ F	コ ン デ ン サ		U
	UW 63 91 00	Electrolytic Capacitor	1000 $\mu$ F/16V	ケ ミ コ ン		
	UW 85 92 20	- do. -	2200 $\mu$ F/35V	"		
※	GA 82 63 00	Power Transformer		電 源 ト ラ ン ス		J
※	GA 82 64 00	- do. -		"		U,C
※	GA 82 65 00	- do. -		"		G
	GE 30 03 50	Choke Coil	68 $\mu$ H	チ ョ ー ク コ イ ル		
	GE 90 01 70	OSC Coil	125 $\mu$ H	O S C コ イ ル		
	GE 90 05 00	Coil	CK4	コ イ ル		U
	HL 31 24 70	Metal Oxide Film Resistor	0.47 $\Omega$ 1P	酸 金 抵 抗		
	HL 31 34 70	- do. -	4.7 $\Omega$ 1P	"		
	HL 31 36 80	- do. -	6.8 $\Omega$ 1P	"		
	HL 31 51 80	- do. -	180 $\Omega$ 1P	"		
	HL 31 54 70	- do. -	470 $\Omega$ 1P	"		
	HL 31 55 60	- do. -	560 $\Omega$ 1P	"		
	HQ 23 00 20	Slide Variable Resistor	A10K $\Omega$	ス ラ イ ド ボ リ ュ ー ム	EG DEPTH	
	HQ 23 00 40	- do. -	B100K $\Omega$	"	SPEED	
	HQ 23 00 50	- do. -	B100K $\Omega$	"	DELAY	
	HQ 23 00 60	- do. -	B10K $\Omega$	"	CUTOFF, FEET, DEPTH RESONANCE, SUSTAIN	
	HQ 23 00 80	- do. -	C100K $\Omega$	"	PERCUSSIVE, ORGAN STRING, VOLUME	
	HQ 23 01 10	- do. -	A2M $\Omega$	"	ATTACK, DECAY RELEASE	
※	HQ 23 01 40	- do. -	B10K $\Omega$ x 2	"	BRILLIANCE	
	HS 31 05 50	Variable Resistor	A10K $\Omega$	ロ ー タ リ ー ボ リ ュ ー ム	MASTER VOLUME	
	HS 31 05 70	- do. -	B10K $\Omega$	"	PITCH	
	HT 19 00 30	Semi Variable Resistor	B2K $\Omega$	半 固 定 抵 抗		
	HT 19 00 40	- do. -	B5K $\Omega$	"		
	HT 19 00 50	- do. -	B10K $\Omega$	"		
	HT 19 00 80	- do. -	B100K $\Omega$	"		
	HT 19 00 90	- do. -	B200K $\Omega$	"		

※ New Parts (新規部品)

Ref. No.	Part No.	Description	部 品 名	Remarks	Common Model	Markets
	HU 57 61 00	Metal Film Resistor	1K $\Omega$	金 皮 抵 抗		
	HU 57 72 20	- do. -	22K $\Omega$	"		
	HU 57 72 70	- do. -	27K $\Omega$	"		
	HV 55 43 30	Flame-Proof Carbon Resistor	33 $\Omega$	不 燃 化 カ ー ボ ン 抵 抗		
	KA 30 04 30	Toggle Switch		ト グ ル ス イ ッ チ	POWER	J
	KA 30 04 70	- do. -		"		G
	KA 30 05 80	- do. -		"		U
	KA 30 06 00	- do. -		"		C
	KA 40 07 90	Slide Switch		ス ラ イ ド ス イ ッ チ	SUSTAIN	
	KA 40 08 20	- do. -		"		G
	KA 90 17 01	Push Switch W/LED	Gray	プ ッ シ ュ ス イ ッ チ		
	KB 00 02 00	Fuse	0.5A 125V	ヒ ュ ー ズ		J
	KB 00 03 30	- do. -	1A 250V	"		J
	KB 00 05 50	- do. -	1A 250V	"		G
	KB 00 06 50	- do. -	T315mA 250V	"		G
	KB 00 10 20	- do. -	1A 250V	"		U,C
	KB 00 11 50	- do. -	0.5A 250V	"		U,C
*	KC 00 12 50	Relay	MZ-12	リ レ ー		
	MG 00 02 70	AC Cord		電 源 コ ー ド		C
	MG 00 06 00	- do. -		"		J
	MG 00 07 10	- do. -		"		U
	MG 00 08 60	- do. -		"		G
	LB 20 15 40	Phone Jack	JL2B	ジ ャ ッ ク		
	LB 20 15 30	Fuse Holder Pin		ヒ ュ ー ズ ホ ル ダ ー ピ ン		
	LB 50 02 50	Connector Base Pin	5P	2.5ピッチベースピン	Top Entry	
	LB 60 24 60	- do. -	7P	"	- do. -	
	LB 60 24 90	- do. -	8P	"	- do. -	
	LB 60 24 70	- do. -	10P	"	- do. -	
	LB 60 31 30	- do. -	12P	"	- do. -	
	LB 60 25 00	- do. -	7P	"	Side Entry	
	LB 50 03 70	- do. -	5P	"	Bottom Entry	
	LB 60 30 00	- do. -	7P	"	- do. -	
	LB 60 30 10	- do. -	8P	"	- do. -	
	LB 60 30 70	- do. -	10P	"	- do. -	
	LB 50 02 40	Connector Housing	5P	ハ ウ ジ ン グ		
	LB 60 24 40	- do. -	7P	"		
	LB 60 24 80	- do. -	8P	"		
	LB 60 24 50	- do. -	10P	"		
	LB 60 29 20	- do. -	12P	"		
	BB 00 24 30	Contact Pin		コ ン タ ク ト ピ ン		

\* New Parts (新規部品)

B. Keyboard Assembly

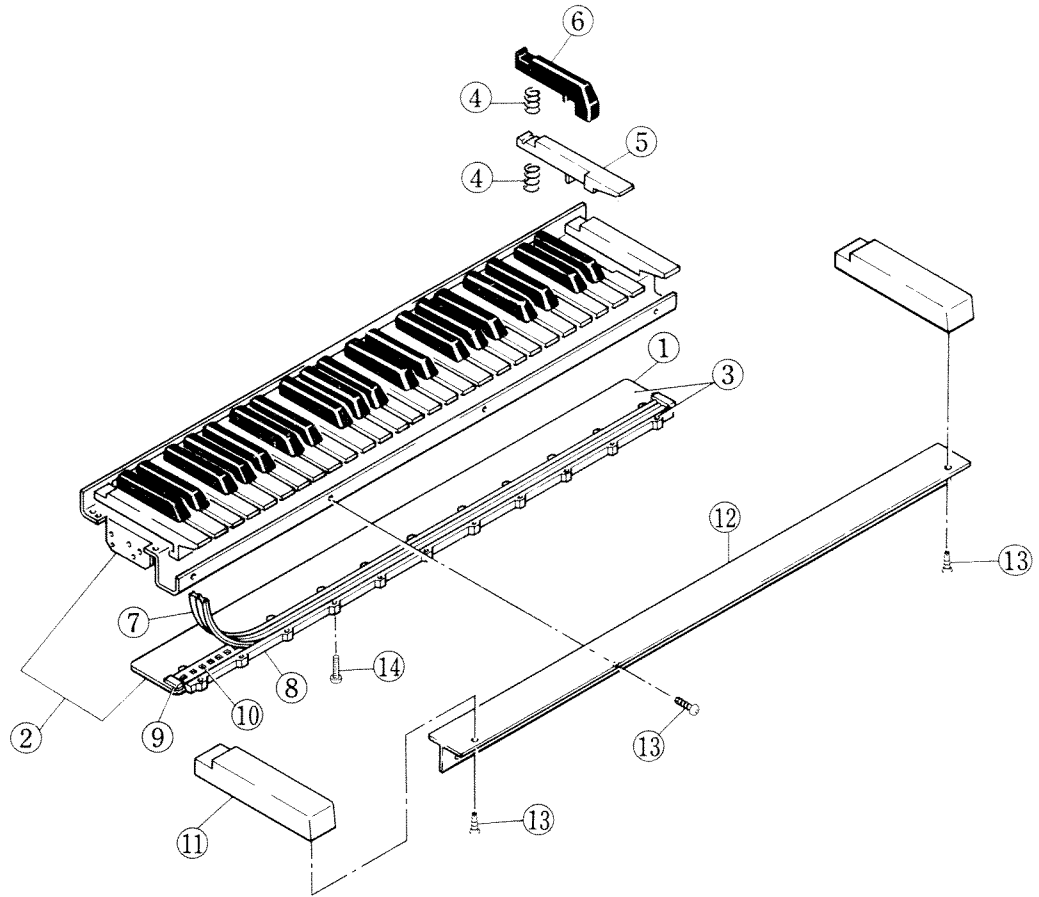

Ref. No.	Part No.	Description	部品名	Remarks	Common Model	Markets
* 1	NA:10:69:10	Circuit Board, MK	#2921	M K シ ー ト		
* 2	NB:10:33:20	Keyboard Assembly		鍵 盤 Ass'y		
* 3	NB:10:33:30	Switch Unit		スイッチユニット		
4	AA:04:37:20	Coil Spring		コイルスプリング		
5	CB:03:22:10	White Key	C, F	白 鍵		
	CB:03:22:20	- do. -	D	"		
	CB:03:22:30	- do. -	B, E	"		
	CB:03:22:40	- do. -	G	"		
	CB:03:22:50	- do. -	A	"		
	CB:03:22:60	- do. -	C'	"		
6	CB:03:22:70	Black Key		黒 鍵		
7	CB:03:23:20	Rubber Contact		可 動 導 電 ゴ ム		
8	CB:03:24:00	Holder	12 Keys	基 板 ホ ル ダ ー (Q)		
	CB:03:24:10	- do. -	13 Keys	" (K)		
9	CB:03:35:40	End Plate		エ ン ド プ レ ー ト		
10	CB:03:35:70	Isolation Spacer	12 Keys	絶 縁 ス ペ ー サ (Q)		
	CB:03:35:80	- do. -	13 Keys	" (K)		
11	CB:81:50:10	End Block		拍 子 木		
12	CB:81:51:20	Front Rail		ロ 樺 レ ー ル		
13	Ei:34:01:00	Bind Tapping Screw	4 x 10	BL	バ イ ン ド タ ッ ピ ン グ ネ ジ	
14	EZ:33:01:40	Bind Screw	M3 x 14	Ye	エ ー パ ー タ イ ト バ イ ン ド ネ ジ	

\* New Parts (新規部品)

C. Control Panel

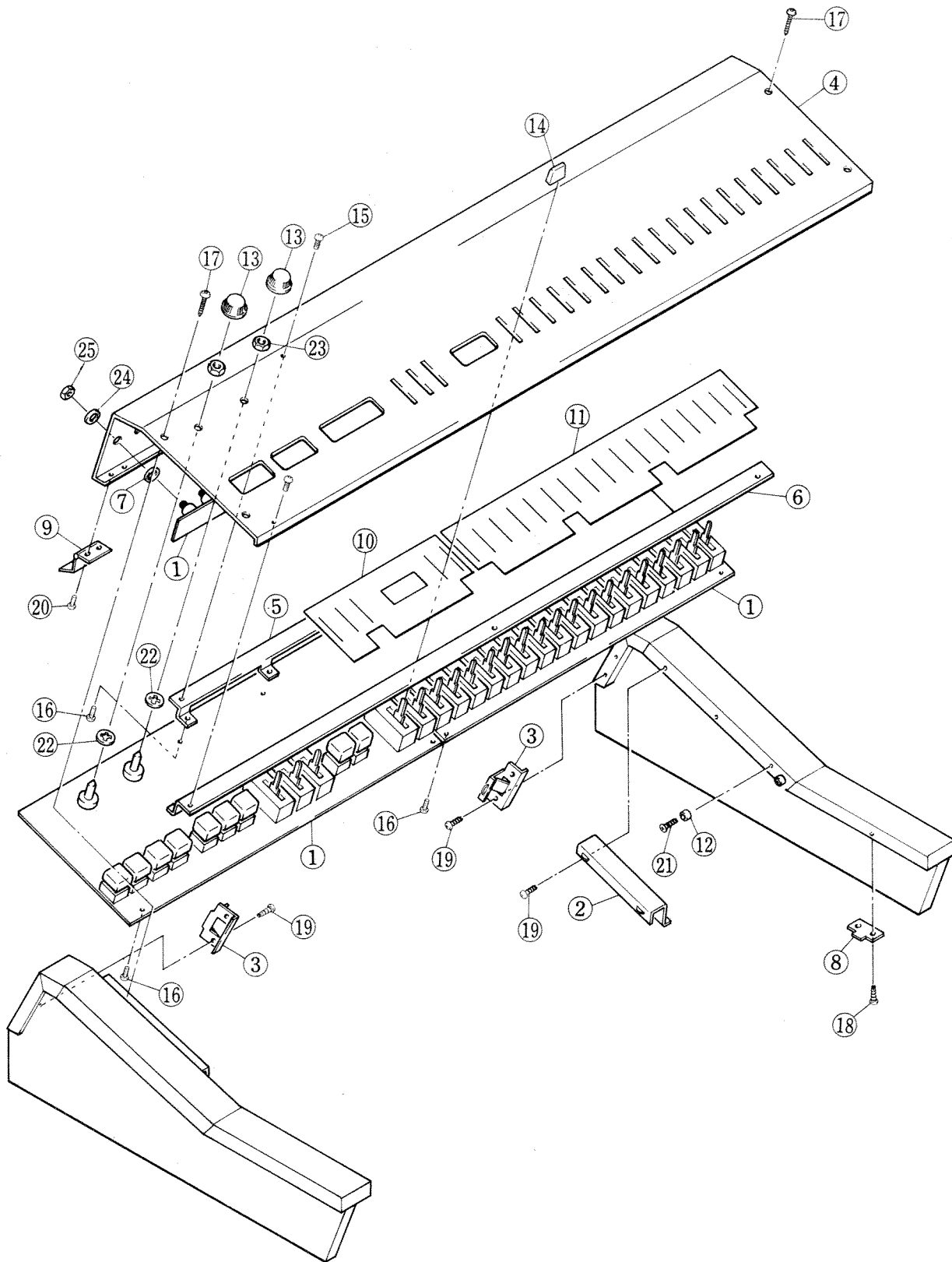

Ref. No.	Part No.	Description	部 品 名		Remarks	Common Model	Markets
* 1	NA 10 71 40	Circuit Board, CPA. CPB. JA	#2894	CPA・CPB・JAシート			
* 2	NB 10 32 80	Panel Angle Assembly		パネルアングル Ass'y			
* 3	NB 10 32 90	Rear Panel Angle Assembly		リアパネルアングル Ass'y			
* 4	AA 05 23 30	Control Panel		コントロールパネル			
* 5	AA 05 23 40	Circuit Board Angle		シートアングル			
* 6	AA 05 23 50	— do. —		"			
* 7	AA 05 23 60	Jack Spacer		ジャックスペーサー			
* 8	AA 05 28 30	End Block Holder		拍子木止め			
	AA 81 12 40	Hinge		蝶番			
* 10	CA 01 29 50	Dust-Proof Cover		防塵クロス			
* 11	CA 01 29 60	— do. —		"			
	CB 03 30 70	Stopper		回転止め			
	CB 81 21 40	Knob		ツマミ			
	CB 81 69 60	— do. —	Yellow	"			
	CB 81 69 70	— do. —	Gray	"			
	CB 81 69 80	— do. —	White	"			
	EC 33 00 60	Truss Screw	M3 x 6	BL	トラス小ネジ		
	ED 33 00 60	Bind Screw	M3 x 6	BL	バインド小ネジ		
	ED 93 01 00	— do. —	M3 x 10	BL	"		
	Ei 03 51 00	Bind Tapping Screw	3.5 x 10	Ye	バインドタッピングネジ		
	Ei 03 51 50	— do. —	3.5 x 15	Ye	"		
	EM 13 00 80	Oval Head Tapping Screw	3 x 8	Ni	丸皿タッピングネジ		
	EO 04 01 60	Flat Head Tapping Screw	4 x 16	Ye	皿タッピングネジ		
	EV 41 00 70	Toothed Lock Washer	A7S	Ye	歯付座金		
	EZ 30 70 10	Hexagonal Nut	7S	Ye	特殊六角ナット		
	LX 20 00 10	Flat Washer	9S	Cr	特殊平座金		
	LX 20 00 60	Hexagonal Nut	9S	Cr	特殊六角ナット		

\* New Parts (新規部品)

D. Cabinet Assembly

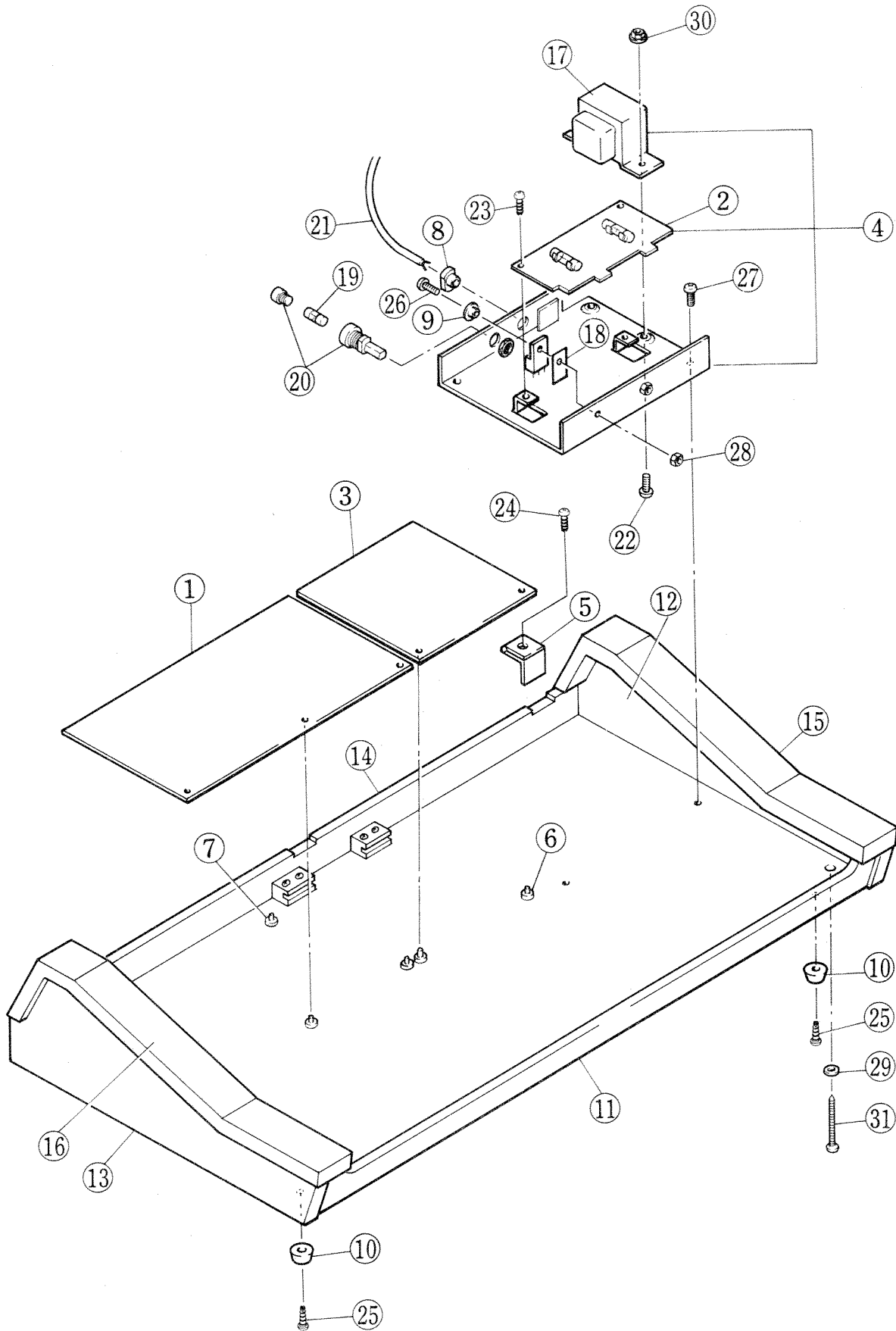



Ref. No.	Part No.	Description	部 品 名	Remarks	Common Model	Markets
* 1	NA:10:71:50	Circuit Board, DM	#2895	D M シ ー ト		
* 2	NA:10:71:60	- do. - , DC	#8555	D C シ ー ト		J
* 3	NA:10:71:70	- do. - , - do. -	- do. -	"		U
* 4	NA:10:71:80	- do. - , - do. -	- do. -	"		C
* 5	NA:10:71:90	- do. - , - do. -	- do. -	"		G
3	NA:80:68:60	- do. - , TE	#8604	T E シ ー ト		
* 4	NB:10:33:40	Power Supply Unit		電 源 ユ ニ ッ ト		J
* 5	NB:10:33:50	- do. -		"		U
* 6	NB:10:33:60	- do. -		"		C
* 7	NB:10:33:70	- do. -		"		G
5	AA:81:12:40	Hinge		蝶 番		
6	CB:03:97:50	Holder, Circuit Board		シ ー ト ホ ル ダ ー		
7	CB:04:00:80	- do. -		"		
8	CB:06:86:30	Cord Bushing		コ ー ド ブ ッ シ ュ		J
	CB:07:27:50	- do. -		"		G
	CB:80:68:50	- do. -		"		U,C
9	CB:07:28:80	Insulation Bushing		絶 縁 ブ ッ シ ュ		
10	CB:80:12:70	Leg		ゴ ム 脚		
* 11	DC:04:72:00	Case Assembly		外 装 集 成		J,C,G
* 12	DC:04:72:30	- do. -		"		U
* 13	DA:02:44:80	Side-Board Assembly (R)		側 板 集 成 (右)		J,C,G
* 14	DA:02:46:30	- do. - (R)		" "		U
* 15	DA:02:44:90	- do. - (L)		" (左)		J,C,G
* 16	DA:02:46:40	- do. - (L)		" "		U
* 17	DA:02:45:00	Back Board Assembly		背 面 板 集 成		J,C,G
* 18	DA:02:46:50	- do. -		"		U
* 19	DA:02:45:10	Side-Arm Assembly (R)		腕 木 集 成 (右)		J,C,G
* 20	DA:02:46:60	- do. - (R)		" "		U
* 21	DA:02:45:20	- do. - (L)		" (左)		J,C,G
* 22	DA:02:46:70	- do. - (L)		" "		U
* 23	GA:82:63:00	Power Transformer		電 源 ト ラ ン ス		J
* 24	GA:82:64:00	- do. -		"		U,C
* 25	GA:82:65:00	- do. -		"		G
18	IL:00:02:70	Mica Base		マ イ カ ベ ー ス		
19	KB:00:02:00	Fuse	0.5A 125V	ヒ ュ ー ズ		J
	KB:00:06:50	- do. -	T315mA 250V	"		G
	KB:00:11:50	- do. -	0.5A 250V	"		U,C
20	LB:20:04:90	Fuse Holder		ヒ ュ ー ズ ホ ル ダ ー		J,U,C
	LB:20:05:90	- do. -		"		G
21	MG:00:02:70	AC Cord		電 源 コ ー ド		C
	MG:00:06:00	- do. -		"		J
	MG:00:07:10	- do. -		"		U
	MG:00:08:60	- do. -		"		G
22	ED:34:01:00	Bind Screw	M4 x 10 BL	バ イ ン ド 小 ネ ジ		
23	EI:33:00:80	Bind Tapping Screw	3 x 8 BL	バ イ ン ド タ ッ ピ ン グ ネ ジ		
24	EI:33:01:20	- do. -	3 x 12 BL	"		
25	EI:34:01:60	- do. -	4 x 16 BL	"		
26	EL:02:60:80	Sems Screw	2.6 x 8 Ye	セ ム ス 小 ネ ジ		
27	EL:34:01:40	- do. -	4 x 14 BL	"		
28	EV:10:02:60	Hexagonal Nut	2.6S Ye	六 角 ナ ッ ト		
29	EV:20:30:50	Flat Washer	5S	平 座 金		
30	EV:98:04:60	Hexagonal Nut	5S	フ ラ ン ジ ナ ッ ト		
31	ED:95:03:50	Bind Screw	M5 x 35 BL	尖 先 バ イ ン ド 小 ネ ジ		

\* New Parts (新規部品)



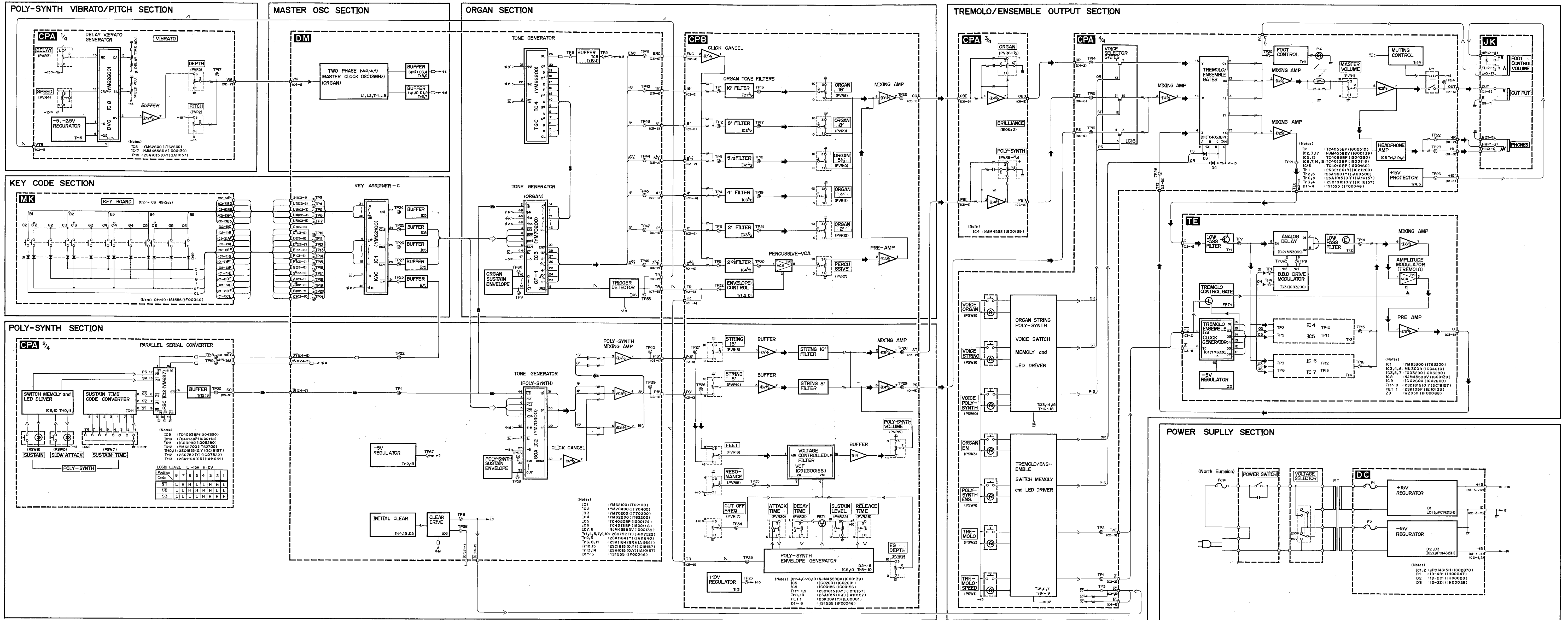

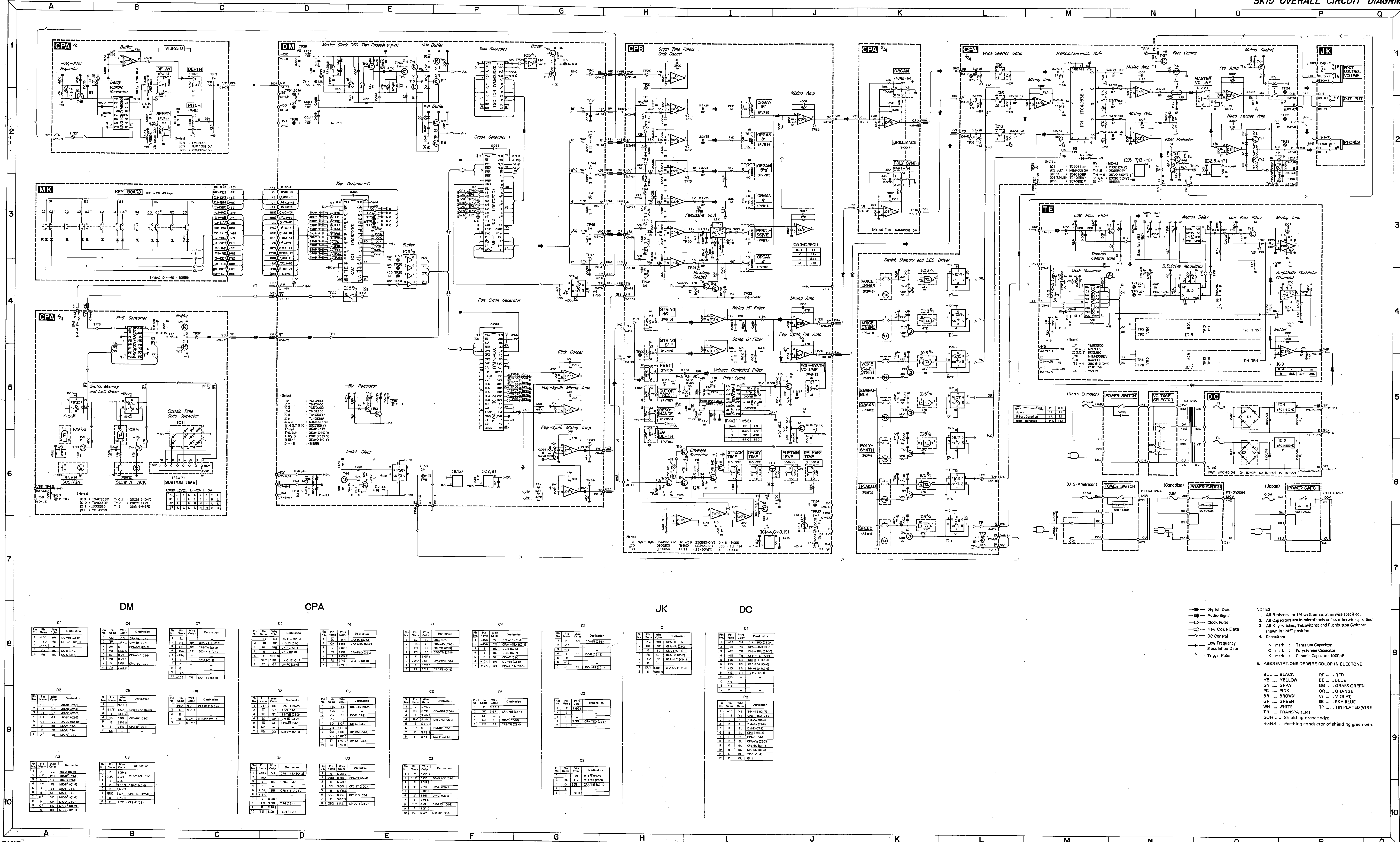

DM

CPA

JK

DC

Pin No.	Pin Name	Wire Color	Destination
1	15SD	BR	DC-15 (C1-1)
2	15D	YE	DC-15 (C1-1)
3	15DA	BL	DC-15 (C1-1)
4	15A	BL	DC-15 (C1-1)
5	15B	BL	DC-15 (C1-1)

Pin No.	Pin Name	Wire Color	Destination
1	15A	BL	DC-15 (C1-1)
2	15B	BL	DC-15 (C1-1)
3	15C	BL	DC-15 (C1-1)
4	15D	BL	DC-15 (C1-1)
5	15E	BL	DC-15 (C1-1)

Pin No.	Pin Name	Wire Color	Destination
1	15A	BL	DC-15 (C1-1)
2	15B	BL	DC-15 (C1-1)
3	15C	BL	DC-15 (C1-1)
4	15D	BL	DC-15 (C1-1)
5	15E	BL	DC-15 (C1-1)

Pin No.	Pin Name	Wire Color	Destination
1	15A	BL	DC-15 (C1-1)
2	15B	BL	DC-15 (C1-1)
3	15C	BL	DC-15 (C1-1)
4	15D	BL	DC-15 (C1-1)
5	15E	BL	DC-15 (C1-1)

Pin No.	Pin Name	Wire Color	Destination
1	15A	BL	DC-15 (C1-1)
2	15B	BL	DC-15 (C1-1)
3	15C	BL	DC-15 (C1-1)
4	15D	BL	DC-15 (C1-1)
5	15E	BL	DC-15 (C1-1)

Pin No.	Pin Name	Wire Color	Destination
1	15A	BL	DC-15 (C1-1)
2	15B	BL	DC-15 (C1-1)
3	15C	BL	DC-15 (C1-1)
4	15D	BL	DC-15 (C1-1)
5	15E	BL	DC-15 (C1-1)

Pin No.	Pin Name	Wire Color	Destination
1	15A	BL	DC-15 (C1-1)
2	15B	BL	DC-15 (C1-1)
3	15C	BL	DC-15 (C1-1)
4	15D	BL	DC-15 (C1-1)
5	15E	BL	DC-15 (C1-1)

Pin No.	Pin Name	Wire Color	Destination
1	15A	BL	DC-15 (C1-1)
2	15B	BL	DC-15 (C1-1)
3	15C	BL	DC-15 (C1-1)
4	15D	BL	DC-15 (C1-1)
5	15E	BL	DC-15 (C1-1)

Pin No.	Pin Name	Wire Color	Destination
1	15A	BL	DC-15 (C1-1)
2	15B	BL	DC-15 (C1-1)
3	15C	BL	DC-15 (C1-1)
4	15D	BL	DC-15 (C1-1)
5	15E	BL	DC-15 (C1-1)

Pin No.	Pin Name	Wire Color	Destination
1	15A	BL	DC-15 (C1-1)
2	15B	BL	DC-15 (C1-1)
3	15C	BL	DC-15 (C1-1)
4	15D	BL	DC-15 (C1-1)
5	15E	BL	DC-15 (C1-1)

Pin No.	Pin Name	Wire Color	Destination
1	15A	BL	DC-15 (C1-1)
2	15B	BL	DC-15 (C1-1)
3	15C	BL	DC-15 (C1-1)
4	15D	BL	DC-15 (C1-1)
5	15E	BL	DC-15 (C1-1)

- Legend for signal types:
- Digital Data
  - Audio Signal
  - Clock Pulse
  - Key Code Data
  - DC Control
  - Low Frequency Modulation Data
  - Trigger Pulse
- NOTES:
- All Resistors are 1/4 watt unless otherwise specified.
  - All Capacitors are in microfarads unless otherwise specified.
  - All Keyswitches, Tabswitches and Pushbutton Switches shown in "off" position.
  - Capacitors
    - Δ mark: Tantalum Capacitor
    - mark: Polystyrene Capacitor
    - K mark: Ceramic Capacitor 1000pF
  - ABBREVIATIONS OF WIRE COLOR IN ELECTONE
 

BL	BLACK	RE	RED
YE	YELLOW	BE	BLUE
GY	GRAY	GG	GRASS GREEN
PK	PINK	OR	ORANGE
BR	BROWN	VI	VIOLET
GR	GREEN	SB	SKY BLUE
WH	WHITE	TP	TIN PLATED WIRE
TR	TRANSPARENT	SOR	Shielding orange wire
SGRS	Earthing conductor of shielding green wire		