

YAMAHA COMBO ORGAN YC-30

OWNER'S MANUAL

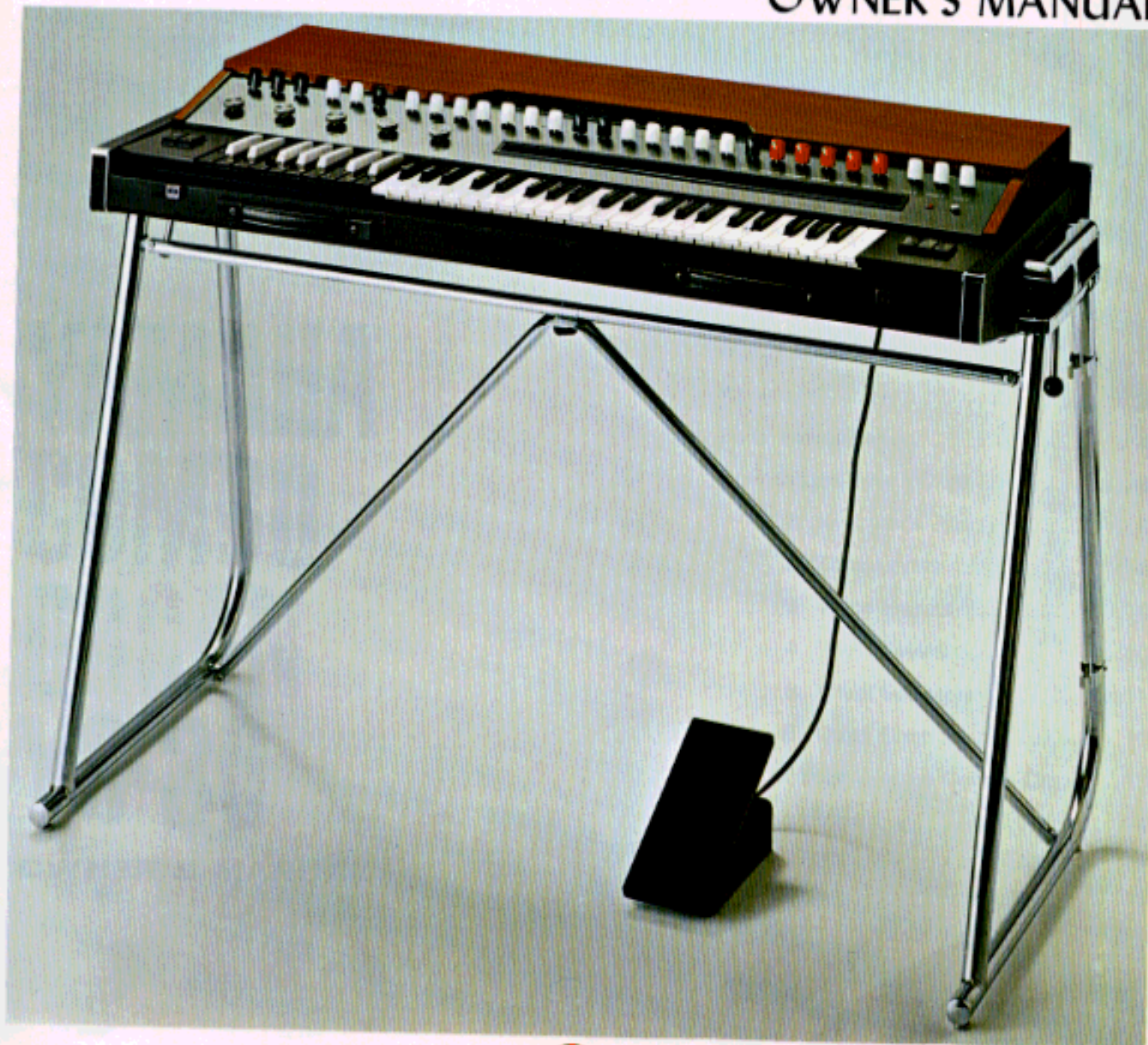

SINCE



1887

YAMAHA COMBO ORGAN YC-30

OWNER'S MANUAL

CONTENTS

Introduction	2
Assembly	3
Parts' Identification	4
How to Use Your YC-30	6
1. Keyboards	6
2. Tone Levers	6
3. Voice Presets	9
4. Effect Levers	10
5. Effect Selectors	11
6. Other Controls	12
Care of Your Yamaha Combo Organ ..	13
Specifications	14

INTRODUCTION

Thank you for selecting the Yamaha YC-30 for your combo organ ! We hope you will read this manual carefully and will experiment with the organs many special features, in order that a more complete understanding of its versatility will be yours.

The Yamaha Combo Organ Model YC-30 has attack and percussive, variable speed marimba, fuzz, sustain, portamento, and bright effects for exactly the tonal rendition you want. And it has the phenomenally popular 'Touch Vibrato' an exclusive Yamaha feature previously available only on the costliest console organs. Another great feature to put you right out in front are the two channels, combined with two presets which duplicate the full two channels twice over.

The above mentioned controls and features will be explained in more detail in the following pages so that you again and please, read on.

ASSEMBLY

1. Remove the 2 legs from the vinyl bag and connect them with screw (A).
2. Install the leg assembly under the main body of the unit and secure them tightly with the four screws (B).
3. Open the cover by releasing catch (C). The expression pedal and power supply cord can then be removed.
4. When standing the unit upright, balance it by adjusting balancing screw (D).
5. The inclination angle of the keyboard can be adjusted to the desired angle by loosening the two levers (E) at both sides of the unit and, after adjusting the keyboard to the desired inclination, lock it in place by tightening these levers. The keyboard can be rotated 120° from the vertical to downwards slope. You have added freedom to play comfortably in any position.

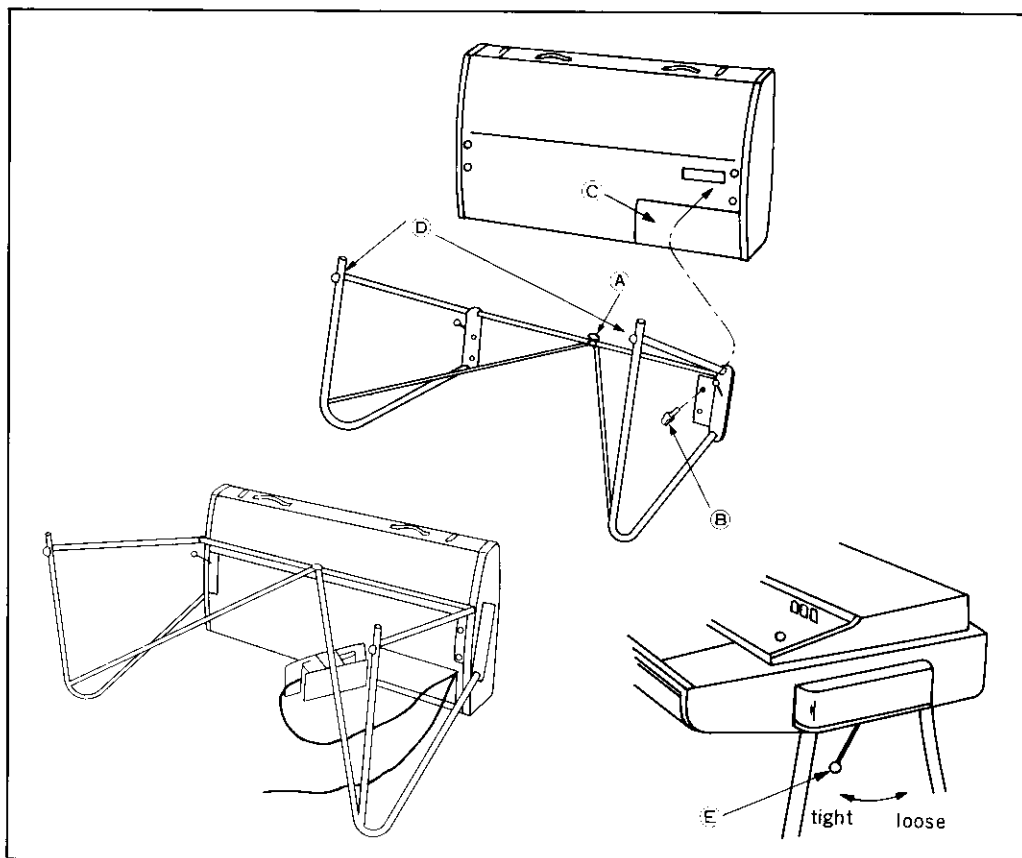

Completely disassembled, parts stored, and cover in place, your YC-30 Combo Organ becomes a convenient, portable unit as shown.

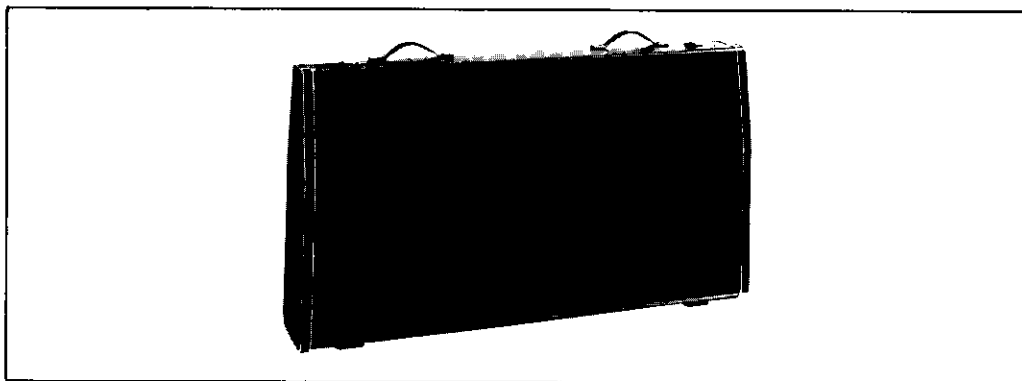

PARTS' IDENTIFICATION

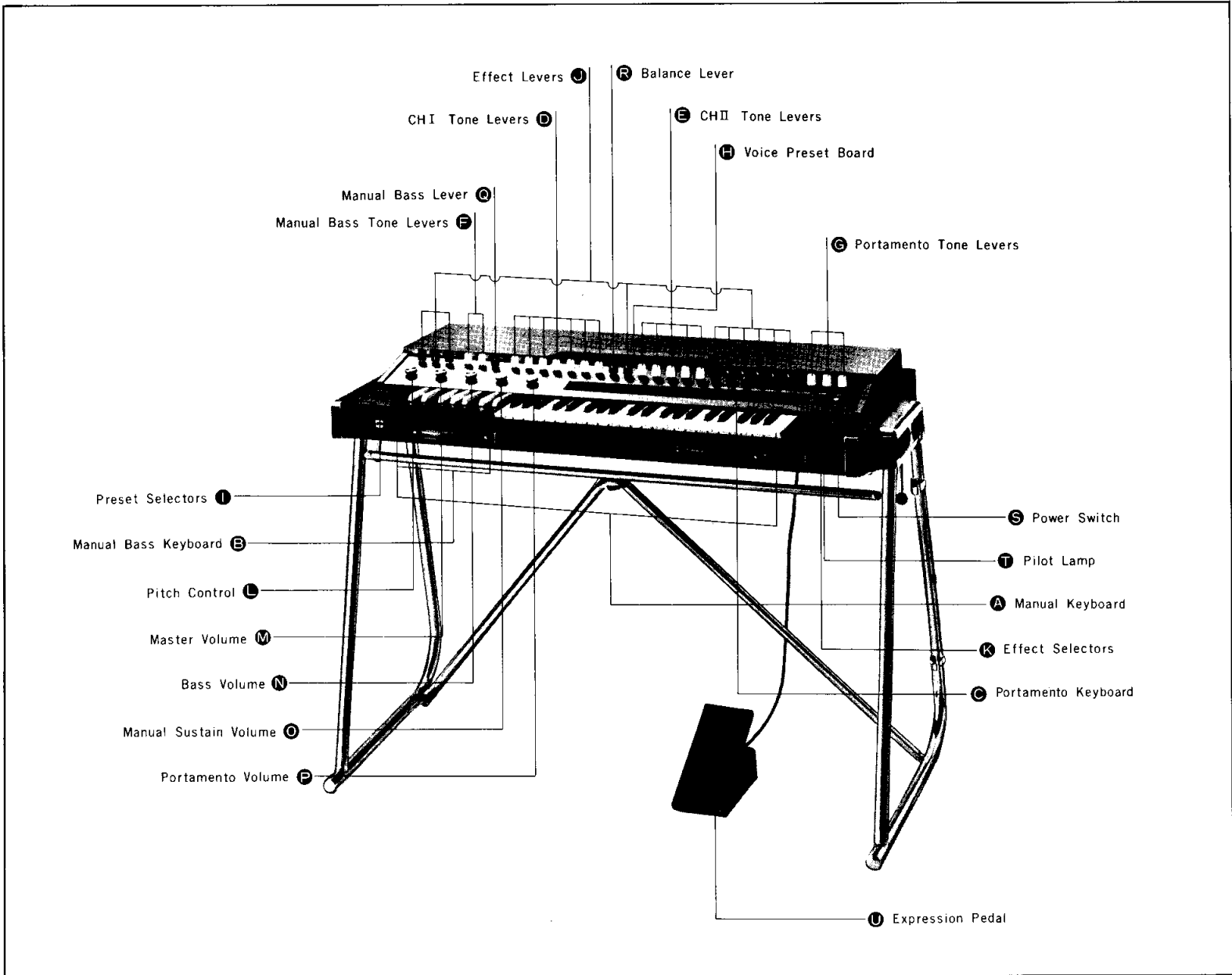

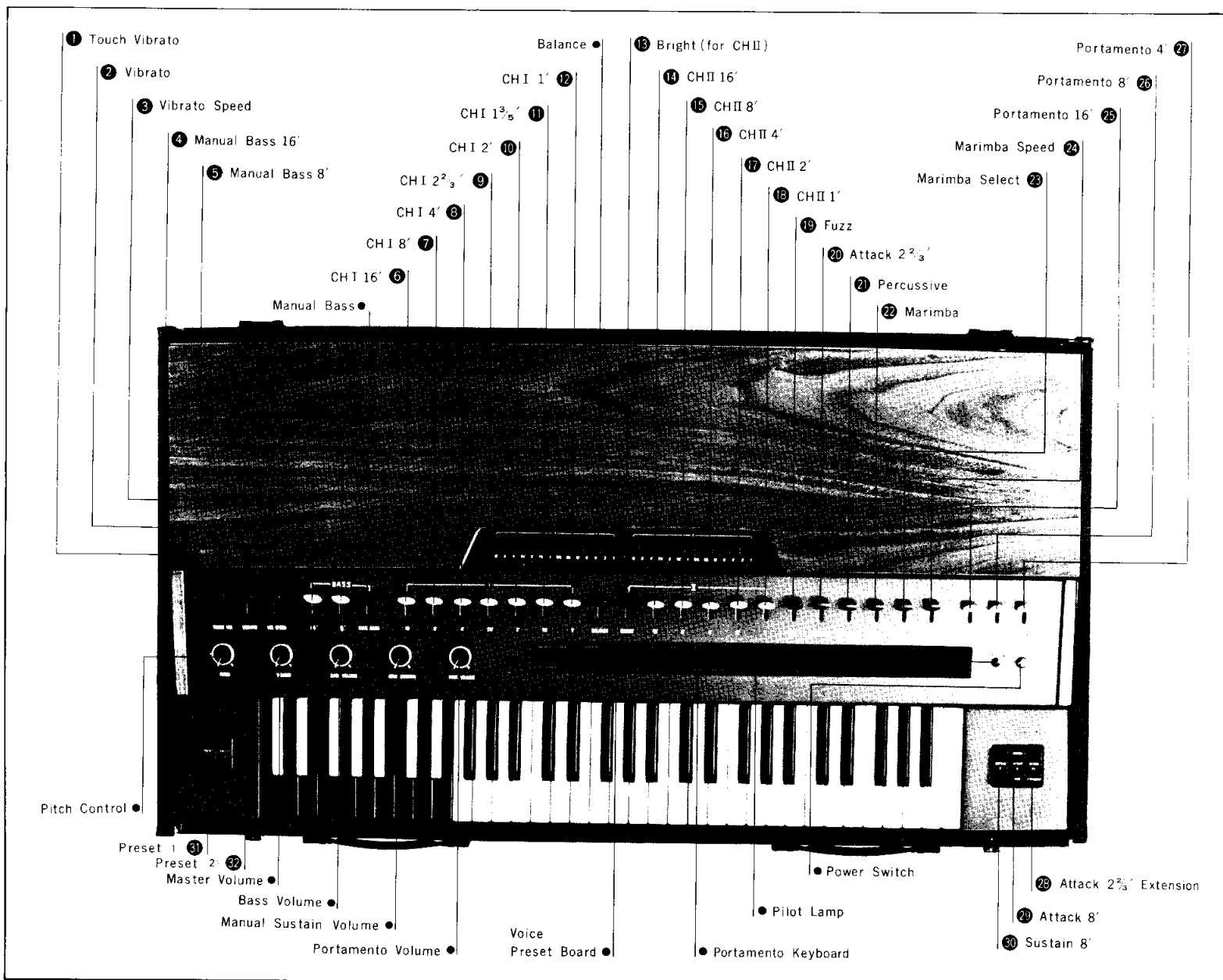

HOW TO USE YOUR YC-30

1. Keyboards

The keyboards of the YC-30 Combo Organ are as follows :

Manual **A** 61 keys C~c₄ (5 octaves)

Manual Bass **B** 17 keys C~e (1½ octaves)

Portamento **C** c₁~c₄ (3 octaves)

The Manual Keyboard has CH.I and CH.II Tone Levers **D****E** for tone color selection.

The 17 bass keys, identified by reverse key colors, become the manual bass section when the

Manual Bass lever **C** is used. At that time, tone color can be selected by the Manual Bass Tone Levers **F**.

The Portamento Keyboard has Portamento Tone Levers **G** for tone color selection. The performer can produce perfectly continuous tone. Depending upon the performance required, Portamento playing, as used for string instruments or vocal music, results in a variety of novel sounds.

2. Tone Levers

On the panel of the Combo Organ, white tone levers are divided into four groups.

- (1) Channel I Tone Levers **D** 7 voices
- (2) Channel II Tone Levers **E** 5 voices
- (3) Manual Bass Tone Levers **F** 2 voices
- (4) Portamento Tone Levers **G** 3 voices

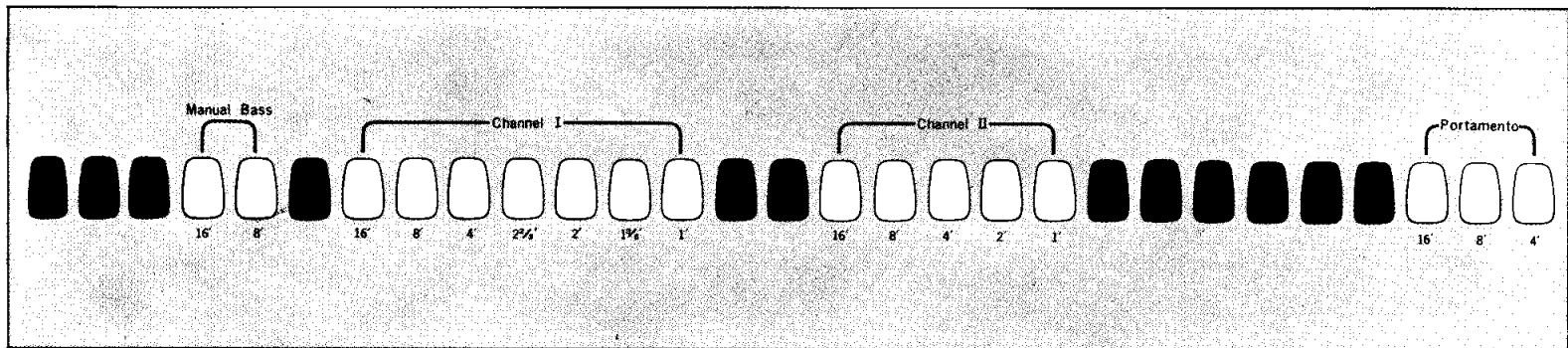

Yamaha's Exclusive Tone Lever System

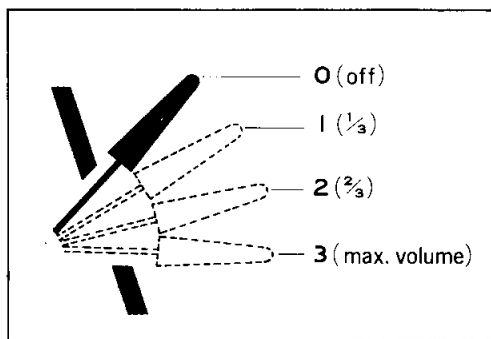

Each tone lever serves to impart a distinctive tonal quality to each note played. However instead of the usual simple on-off action, the Yamaha tone lever offers the unique advantage of continuously variable control. This means that even the finest shadings of volume control can be obtained from each and every lever, an amazing advantage in breadth of expression and ease of playing. For quick changes, another aid to precision is provided: As the tone lever is depressed, two 'click-stop' positions are felt, where the lever catches slightly. These indicate $\frac{1}{3}$ and $\frac{2}{3}$ of the maximum setting attained when

the lever is fully depressed. This exclusive Yamaha tone lever system allows the combination of these tones giving a virtually limitless range of tone, with a full spectrum of rich harmonics.

The Combo Organ YC-30 is thus able to satisfy even the most demanding professional organist. The most important point in developing good tone registration is the early mastery of the tone levers. Make it a practice to listen to good music and build your taste for sounds so you can use the tone levers duplicate them. Experiment in the creation of tone colors to suit your own taste.

Harmonics

Tone levers are of several varieties: 8', 16', $2\frac{2}{3}'$, etc., each variety having a different pitch. The 8' tone levers are 'fundamentals', that is, they have the same pitch as the written note. The others, called 'harmonics' are pitched a certain interval above or below the fundamental. Harmonics can be further subdivided into consonants, at octave intervals from the fundamental and dissonants, separated by a third or a fifth from the fundamental.

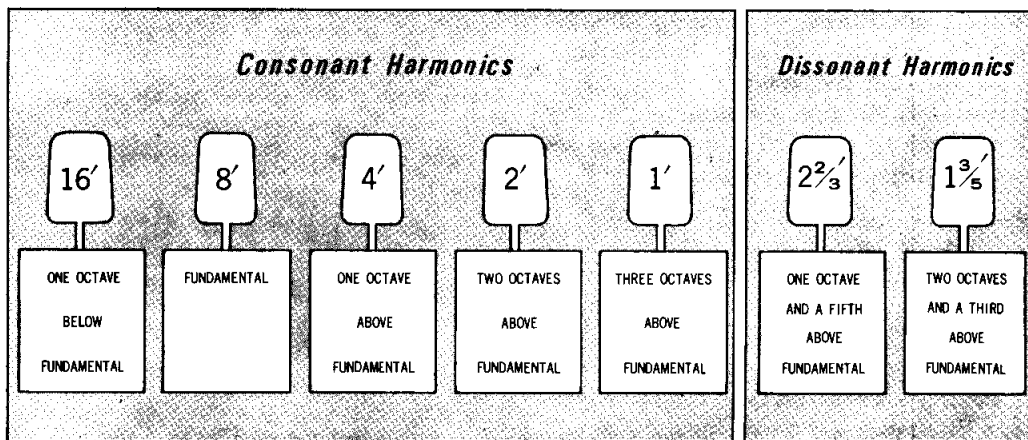

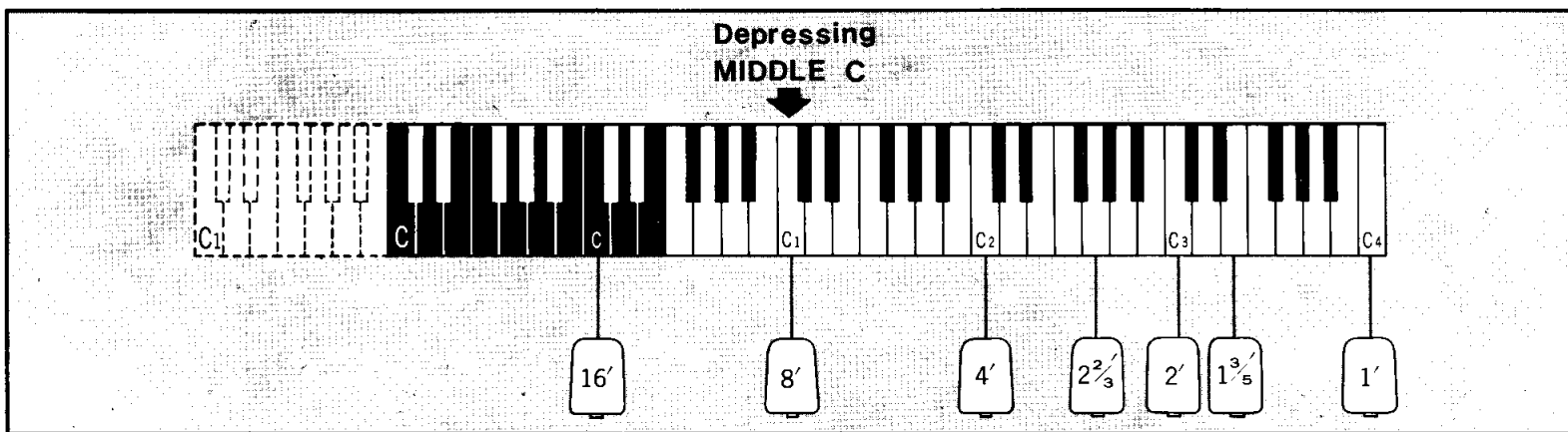

As an example of what this means when you play, let us see which note can be produced by using one of the tone levers and pressing the key of middle C (c_1). Pressing middle C and using the 4' tone lever, for example, will result in the same note as would be produced by pressing c_2 (using the 8' tone lever, i.e. its Fundamental.) It can thus be seen that the use of these harmonic levers actually result in increasing the YC-30 Combo Organ's compass above and below that which is indicated by the keys alone.

The use of the 16' lever, for example, will extend the manuals down an octave to C_1 . (See dotted line above). Similarly the 1' lever raises the tone three octaves but, in actual practice, the highest note on the YC-30 is b_2 . Thus when a scale is continued upward beyond b_2 , the previous octave is repeated. This is no cause for alarm. It is inherent in the design of the YC-30 and will cause you no inconvenience whatever when playing.

The major use of the harmonic levers, however is to increase the richness of tone—they are the spices that, when applied to the fundamental, will give big full sound to the performance.

Let your ears be your guide to the creation of good music, try not to over-work the full effect as this will weaken its effectiveness. Change your registration as often as the mood of the music requires.

CH.I (16' 6, 8' 7, 4' 8, 2²/₃' 9, 2' 10, 1³/₅' 11, 1' 12)

If the Balance Lever **R** is set to the "0" position (far side), the tone color of the Manual Keyboard can be selected by a combination of the CH.I Tone Levers.

The CH.I tone color is the basic sound of the Combo Organ.

CH.II (16' 14, 8' 15, 4' 16, 2' 17, 1' 18)

If the Balance Lever **R** is set to the "3" position (near side), the tone color of the Manual Keyboard can be selected by a combination of the CH.II Tone Levers.

The tone color of CH.II can be widely changed by operation of the Bright Lever **B**. If the Bright Lever is set at "0", a flute-family tone color (a tone color with less overtone) can be produced. If set to "3", a string-family tone color (with rich overtones) can be produced.

CH.I/CH.II

When the Balance Lever **R** is set to the middle position, tone color of the Manual Keyboard can be selected by a combination of the CH.I and CH.II Tone Levers.

Volume (Master Volume) M

Although this control actually belongs to a group of OTHER CONTROLS (page 12), it will be described here because it has a relationship with the Tone Levers. The tones selected with the maximum volume of the tone levers of CH. I, CH.II and Manual Bass are regulated with this control.

Manual Bass F (16' 4, 8' 5)

If the Manual Bass Lever **C** is operated (set to near side), the 17 bass keys identified by reverse key colors, are changed to produce bass tones. Tone color is selected by a combination of the 16' and 8' Manual Bass Tone Levers.

Bass Volume N

This also belongs to a group of OTHER CONTROLS (described later). Tone Volume of Manual Bass can be regulated by the Bass Volume Control, indirectly controlled by the Master Volume **M**.

3. Voice Presets

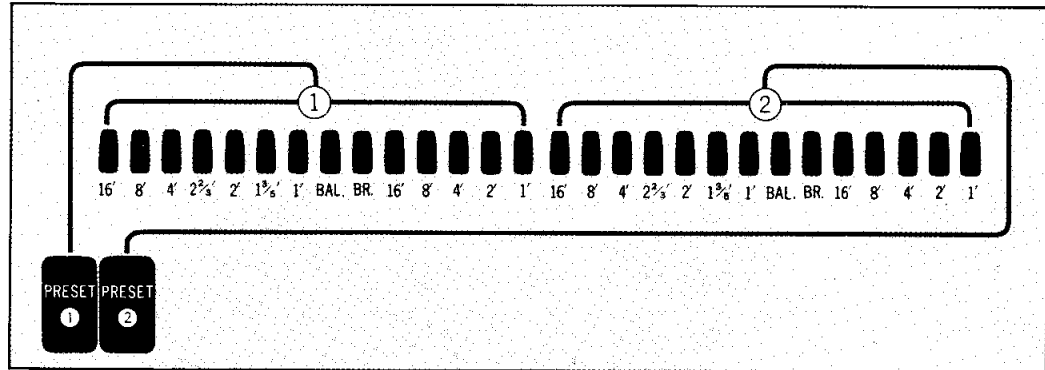

Portamento **G** (16' **25**, 8' **26**, 4' **27**)

An interval of the Portamento Keyboard is almost equivalent to an interval of the Manual Keyboard **A**, and can be changed continuously. A wide range of tone color can be selected by a combination of the 16', 8' and 4' Portamento Tone Levers.

Portamento Volume **P**

This is also one of the OTHER CONTROLS to be described later. Tone volume of Portamento can be regulated by operating the Portamento Volume, indirectly controlled by the Master Volume **M**.

This photograph shows the Voice Preset Board **H**. The numbers **1** and **2** indicate the two rows of miniature tone and effect levers which allow the presetting of two voices. These miniature levers are also continuously variable like the control panel levers duplicating that unique feature, and are arranged in exactly the same order for convenience in setting.

When Preset Selectors **1** **41** and **2** **42** are both used at the same time, **2** will take priority over **1**.

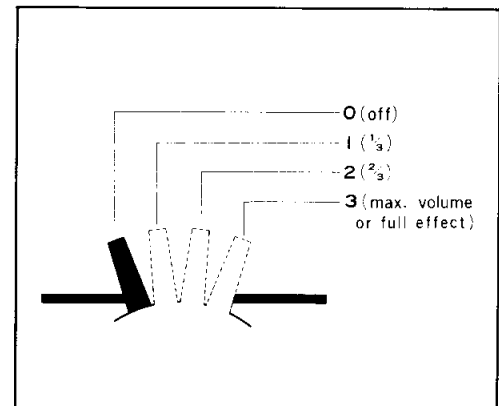

4. Effect Levers

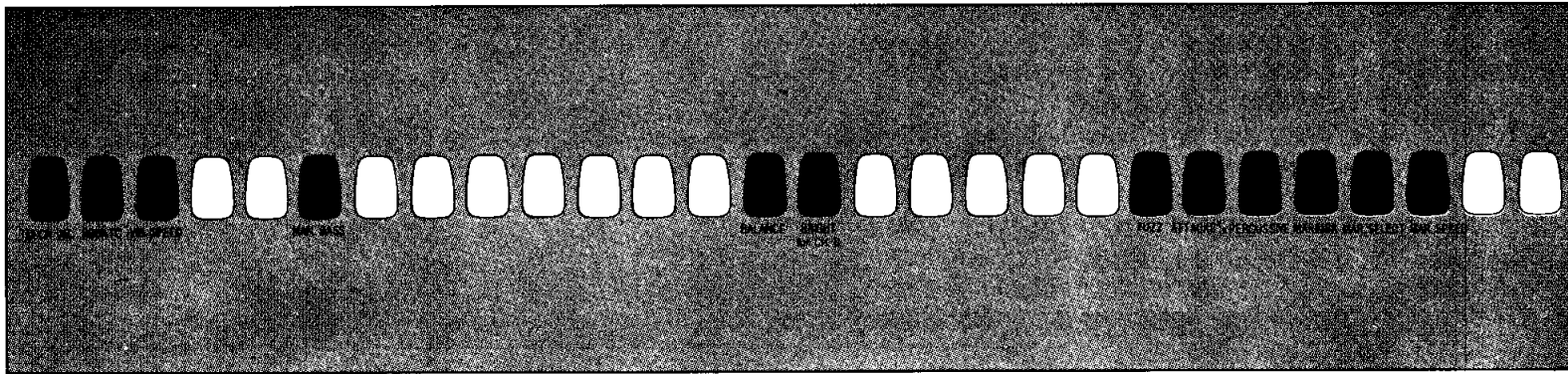

The effect levers ① of the YC-30 provide a wide range of tonal effects which add to the variety of possible combinations. These levers have the same operation as the tone levers and allow the organist to vary the depth or speed of their effects according to their stop positions as illustrated.

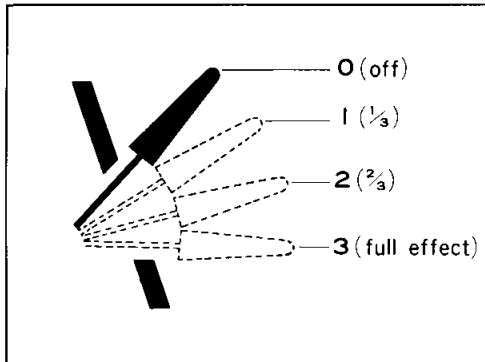

Touch Vibrato ①

In the YC-30, Yamaha offers what no one else can—true vibrato that will thrill you with its sheer magic; will enthrall listeners with its vibrato life. No other electronic organ at any price can match this natural tonal beauty, because no other vibrato effect is produced by the lateral vibration of the hand, just as in the violin, cello or clarinet. This is the 'Touch Vibrato', the most

revolutionary electronic triumph in organ history. Now are opened to you almost endless horizons of expression, all achieved with breathtaking authenticity.

If the Vibrato lever ② is turned on after the Touch Vibrato lever, the latter will be automatically cancelled.

Vibrato ②

The use of vibrato adds a romantic quality to the tone and makes relatively simple passages seem brisk and lively. The depth of the vibrato is controlled by this lever.

Vibrato Speed ③

Used in conjunction with the Vibrato lever, it controls the oscillating speed of the vibrato, which increases as it is pulled down.

Bright (for CH.II) ④

The explanation of this effect is given under CH.II Tone Levers, page 8.

Fuzz ⑤

This novelty effect produces a band of sound centered around the key struck. If the Fuzz lever is turned on, the Fuzz effect is applied only to the CH.I and CH.II tone levers. There will be no effect to Manual Bass, Portamento, Attack, Percussive or Marimba.

Percussive ①

The Percussive lever lends a sharp, vital quality to your playing. Percussive makes only the sound of the first key depressed. If that key is continuously depressed, any subsequent keys produce no sound. Therefore, the first key must first be released before depressing a second key.

Attack $2\frac{2}{3}$ ' ②⑩

The Attack $2\frac{2}{3}$ ' produces a result similar to the Percussive effect but with a distinctive piquancy. If the Attack $2\frac{2}{3}$ ' Extension Selector ⑭ is used, the Attack $2\frac{2}{3}$ ' effect can be extended to all keys. When the Attack $2\frac{2}{3}$ ' Extension Selector is off, Attack $2\frac{2}{3}$ ' applies only down to c_1 .

Marimba ⑳ & Marimba Select ㉓

If the Marimba lever is used when the Marimba Select lever is off (far position), the alternating of two notes, an octave apart resembles the effect of the two marimba mallets and allows a great variety of effects to be added. If the Marimba lever is used when the Marimba Select lever is on (near position), it will be a fifth consecutive strike. This effect adds a light and lively touch to any tune.

Marimba Speed ㉔

The Marimba Speed lever permits selection of a Marimba effect of either about 5 Hz or about 9 Hz.

5. Effect Selectors

The tablet controls located at the right of the Manual Keyboard are the Effect Selectors ㉕. They are all of a two-position design for easy selection while playing.

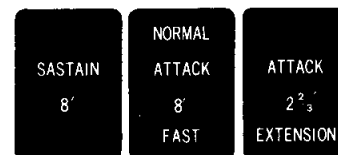

Sustain 8' ㉖

If this selector is used, the Sustain effect will be applied to 8' tones only. The graphs below show examples of the tone when this effect is not used and when it is used.

Attack 8' ㉗

Use the Attack 8' Selector to make the 8' sound "smooth" when the Sustain 8' Selector is not in use. The sound is heard immediately when the key is depressed. It has, however, no effect when the Sustain 8' Selector is in use. When this is graphed, it is as follows.

Manual Sustain Volume ㉘

Although this is one of the OTHER CONTROLS which will be described later, it will be explained here because it has a relationship with the Sustain 8' Selector. The length of Sustain at the Sustain 8' Selector can be regulated by the Manual Sustain Volume. When the Manual Sustain Volume is minimized, the Manual Sustain becomes the same as when the Sustain 8' Selector is off.

Attack $2\frac{2}{3}$ ' Extension ㉙

The explanation of this selector is given at Attack $2\frac{2}{3}$ ' effect lever, page 10.

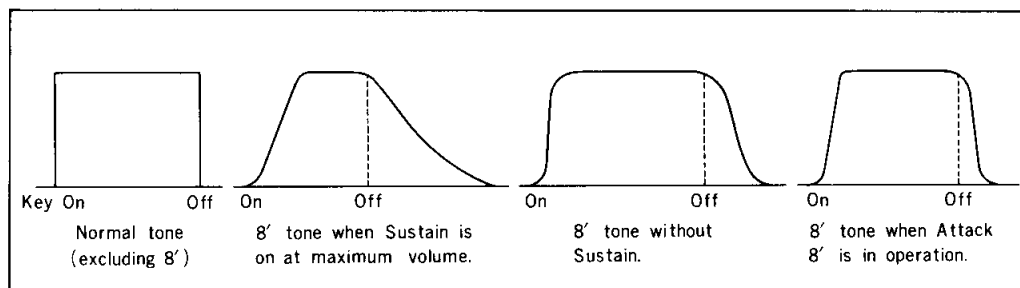

6. Other Controls

Pitch Control **L**

As shown in the figure, it is tuned at A = 440 Hz, the standard pitch. By moving the Pitch Control, a range of from A = 439 – 455 Hz can be obtained. Thus you can tune to match the instruments with you.



Volume (Master Volume) **M**

By using this control, the tone of the Manual Keyboard, as selected by CH.I, CH.II and Manual Bass Tone Levers, can be regulated. (See p. 8)

Bass Volume **N**

Tone volume of Manual Bass Keyboard can be adjusted by this control, indirectly controlled by the Master Volume **M**, (See p. 8)

Manual Sustain Volume **O**

Explanation of this control is given under Manual Sustain Volume, page 11.

Portamento Volume **P**

The tone volume of Portamento can be varied by using this control, indirectly controlled by the Master Volume **M**. (See p. 8)

Manual Bass **C**

By using this lever, the 17 bass keys, identified by reverse key colors, become the manual bass section. At that time, the tone color can be selected by the Manual Bass Tone Levers. (See p. 8)

Balance **R**

Explanation of this lever is given under Tone Levers, page 8.

Power Switch **S** & Pilot Lamp **T**

Pushing the Power Switch once turns it on; pushing it again turns it off; pushing it once more turns it on again. The Pilot Lamp lights to indicate the switch is on.

Expression Pedal **U**

Expressive shading within each piece and the accenting of individual notes can be achieved with this pedal, within the overall range set by the Master Volume, Bass Volume and Portamento Volume Controls.

CARE OF YOUR YAMAHA COMBO ORGAN

In general, you should treat your Combo Organ with the same care you would give any fine musical instrument. However the following points are suggested to assure optimum enjoyment.

1. When you have finished playing, be sure to turn off the power switch.
2. In order to clean manual keys, tabs, etc., use a damp cloth. Never apply household cleaners or solvents such as alcohol, as they may damage the plastic materials used.
3. If your Yamaha Combo Organ becomes inoperative or does not function properly, first follow this simple step-by-step check list before calling for service.
 - (1) Make certain that the line cord is plugged into a live AC outlet. Make sure the wall receptacle is not faulty. (Hum from the speaker may be reduced by reversing the line cord plug in the wall outlet.)
 - (2) Be sure the "ON-OFF" Power Switch is on. Pilot Lamp will light to indicate this.
 - (3) Check the input cord for loose connections or shorts.
 - (4) Make sure the master volume control is turned up at least part way and that the swell shoe is firmly attached and depressed. At least one tone volume lever must be on, and the balance lever set to favor that section of voices.
4. If, after checking the above points, the instrument still seems to be out of order, contact your Yamaha Service Agent. The Yamaha Combo Organ uses IC's and other solid state devices so, do not attempt to touch or otherwise interfere with the circuits or internal elements of this instrument.

CAUTION VOLTAGE SELECTOR

Before you plug in the AC supply, please check that the voltage selector is set to your local current. If not properly set, pull out the socket and reinsert it to the correct voltage position.

Voltage settings: 100, 110, 117, 125, 220 or 240V. U.S., Canadian, European, British and Australian models are set to the proper voltage before shipment.



SPECIFICATIONS OF YAMAHA COMBO ORGAN YC-30

KEYBOARDS

61 keys C~c₄ (17 Bass keys)

Portamento c₁~c₄

TONE LEVERS

Channel I 16' 8' 4' 2 $\frac{2}{3}$ ' 2' 1 $\frac{3}{8}$ ' 1'

Channel II 16' 8' 4' 2' 1'

Manual Bass 16' 8'

Portamento 16' 8' 4'

EFFECT LEVERS & SELECTORS

Touch Vibrato, Vibrato, Vibrato Speed,

Bright (for CH. II), Attack 2 $\frac{3}{4}$ ', Percussive,

Marimba, Marimba Select, Marimba Speed,

Sustain 8', Fuzz, Preset ①, Preset ②, Attack 8',

Attack 2 $\frac{3}{4}$ ' Extension

OTHER CONTROLS

Pitch Control, Master Volume, Bass Volume,

Manual-Bass, Balance, Manual Sustain,

Portamento Volume, Power Switch, Pilot

Lamp, Expression Pedal

ELECTRICAL RATINGS

Silicon Transistors 243

IC's 24

Diodes 154

Power Consumption 25W AC 50~60 Hz

DIMENSIONS

Width 111 cm (43")

Depth 62 cm (24")

Height 92 cm (36") (set up)

Weight 40 kg (88 lbs.)

FINISH

High gloss polyester finish

AVAILABLE COLORS

Black, American Walnut

VINYL CARRYING BAG

Provided for legs which are also included
with the organ.

Specifications subject to change without notice

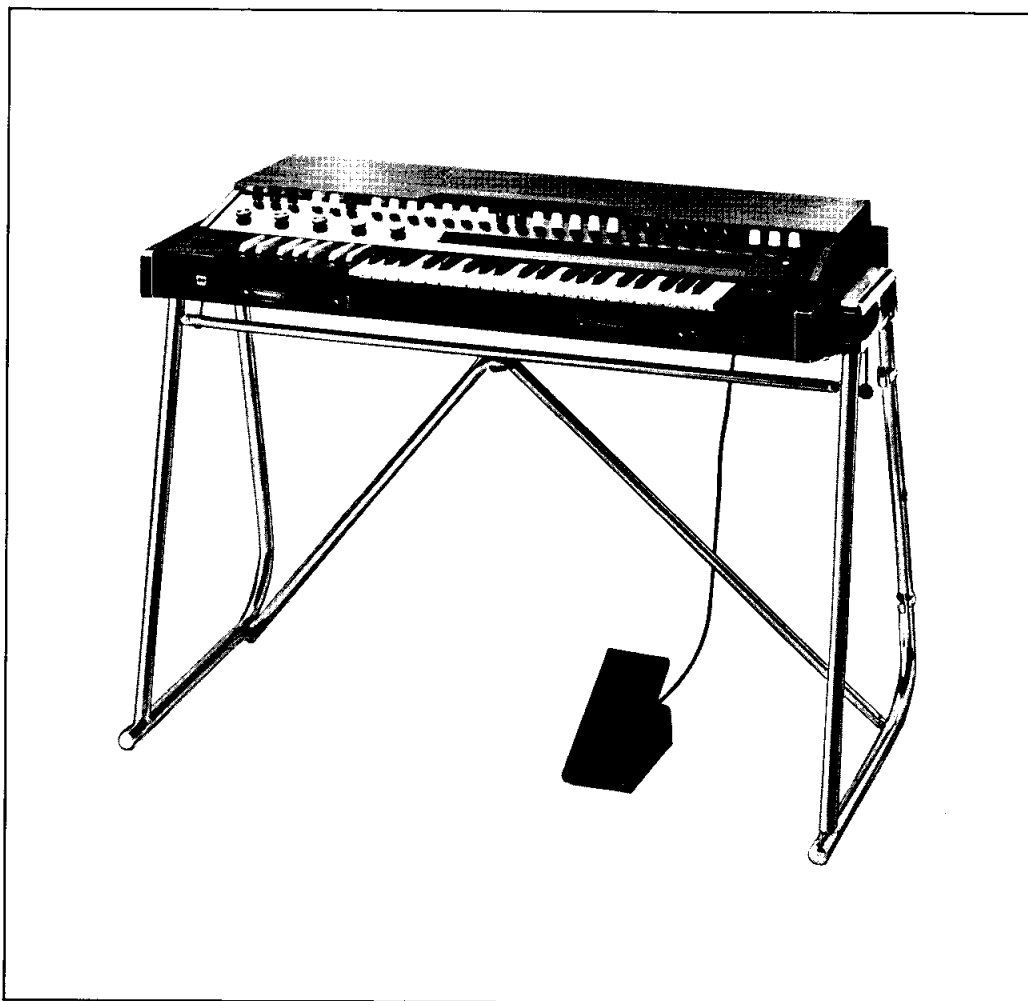

For British-Standard Organist

As the colours of the wires in the mains lead of the apparatus may not correspond with the coloured markings identifying the terminals in your plug proceed as follows. The wire which is coloured GREEN and YELLOW must be connected to the terminal in the plug which is marked by the letter E or by the safety earth symbol \equiv or coloured GREEN or GREEN and YELLOW.

The wire which is coloured BLUE must be connected to the terminal which is marked with the letter N or coloured BLACK.

The wire which is coloured BROWN must be connected to the terminal which is marked with the letter L or coloured RED.

IMPORTANT

THE WIRES IN THE MAINS LEAD ARE COLOURED IN ACCORDANCE WITH THE FOLLOWING CODE.

GREEN AND YELLOW	EARTH
BLUE	NEUTRAL
BROWN	LIVE

WARNING:

THIS APPARATUS MUST BE EARTHED.